

ORIENTATION
 ← FRONT

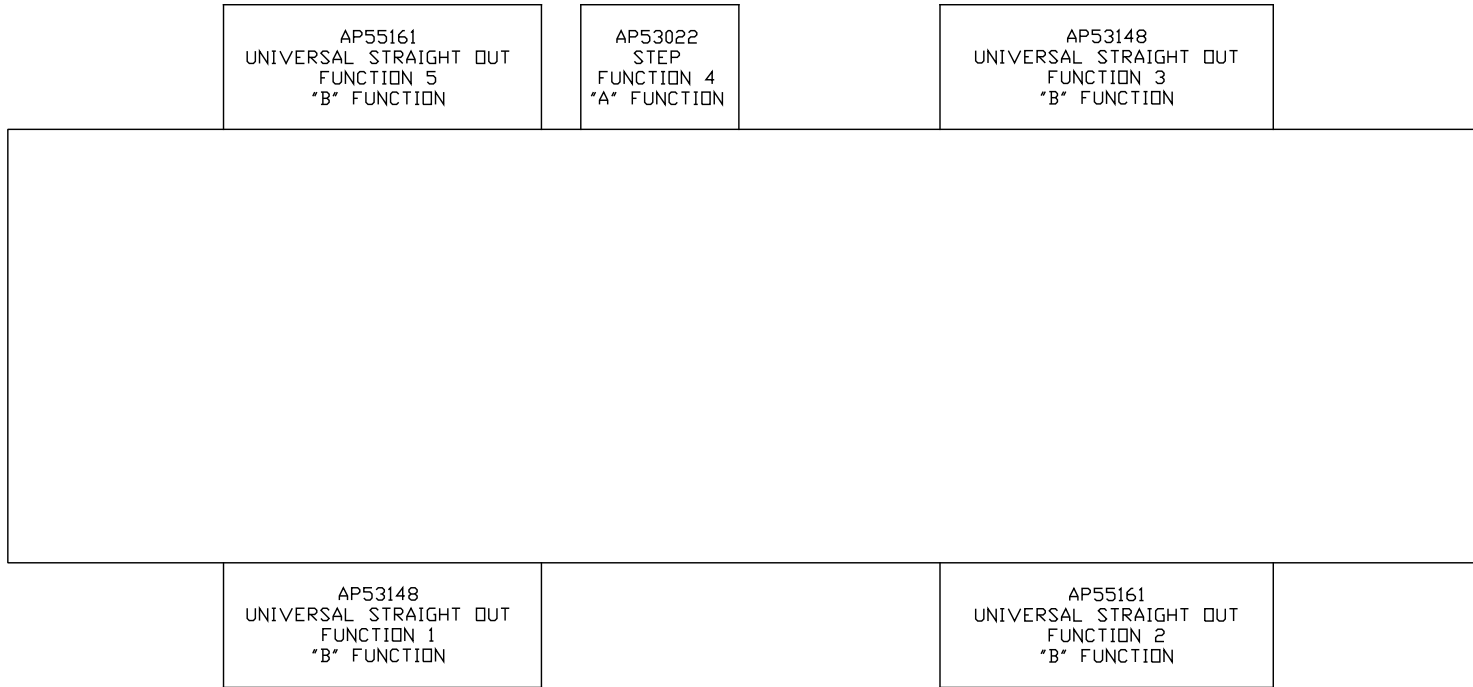

NOTE: INSTALLATION MUST CONFORM TO GOOD SHOP PRACTICES, SAE STANDARDS, RVIA STANDARDS, AND OTHER APPLICABLE STANDARDS.

LEVELING SYSTEM: AP55194

△	16FEB16	WAS AP53219
NO.	DATE	REVISION

THE INFORMATION DISCLOSED ON THIS DRAWING IS CONFIDENTIAL AND MUST NOT BE DISCLOSED OR USED IN ANY MANNER WHICH WILL BE DETRIMENTAL TO THE HWH CORPORATION

HWH			I-80 EXIT 267 SOUTH RT 1 MOSCOW, IOWA 52760		
SCALE 1:6	DATE 08JUN15	DRAWN BY .			
HYD CONN DIAGRAM					
FORETRAVEL				DRAWING NUMBER MP70885 A/G	

ORIENTATION
 ← FRONT

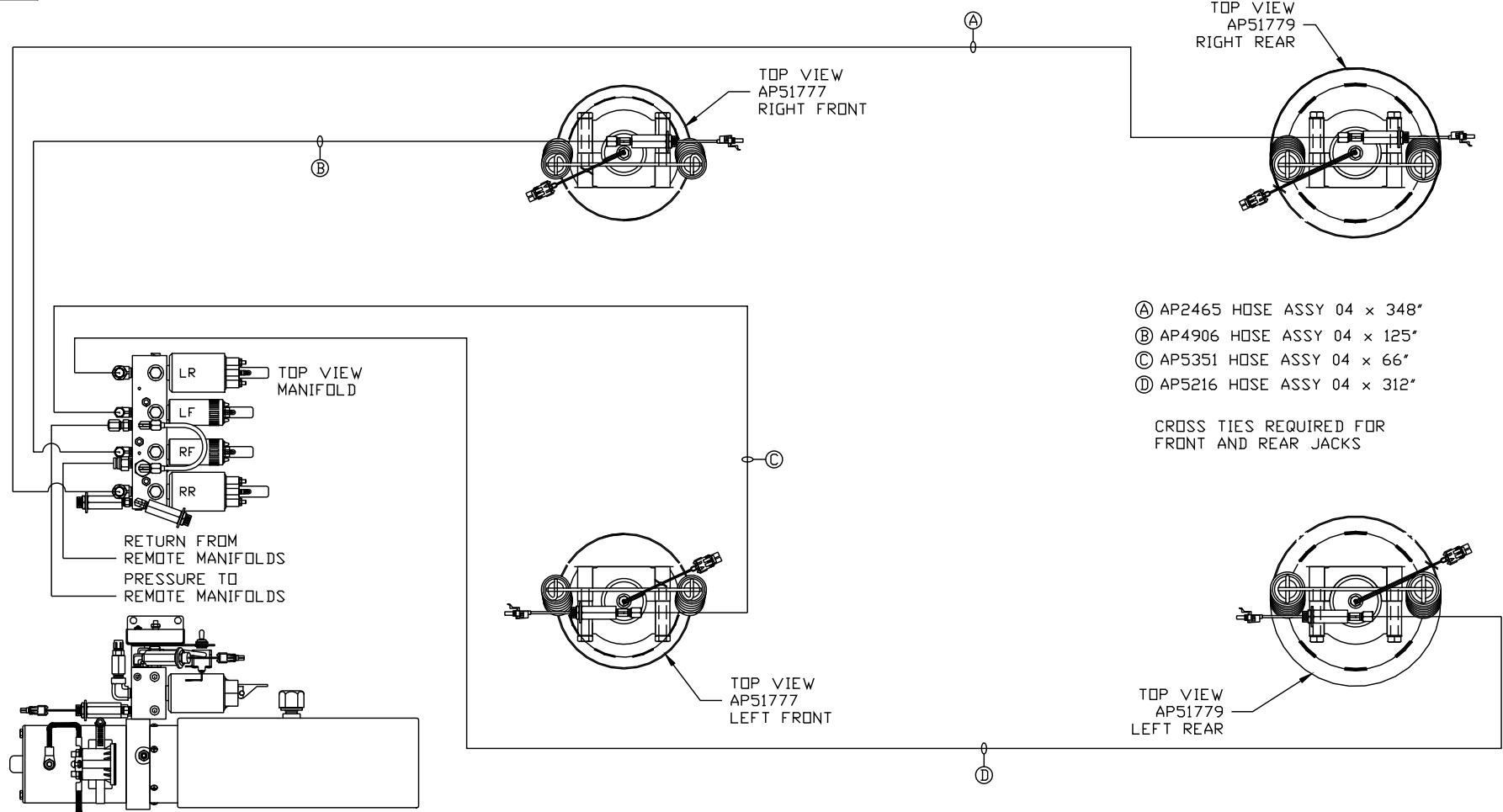

- Ⓐ AP2465 HOSE ASSY 04 x 348"
- Ⓑ AP4906 HOSE ASSY 04 x 125"
- Ⓒ AP5351 HOSE ASSY 04 x 66"
- Ⓓ AP5216 HOSE ASSY 04 x 312"

CROSS TIES REQUIRED FOR FRONT AND REAR JACKS

SIDE VIEW PUMP/MANIFOLD-AP55728 ▲

LOCATION AND ORIENTATION OF PUMP/MANIFOLD ASSEMBLY WILL DIFFER DEPENDING UPON O.E.M.

NOTE: INSTALLATION MUST CONFORM TO GOOD SHOP PRACTICES, SAE STANDARDS, RVIA STANDARDS, AND OTHER APPLICABLE STANDARDS.

- Ⓐ HOSE ASSY 04
PRESSURE
- Ⓑ .375" OD NYLON TUBING
RETURN
- Ⓒ HOSE ASSY 03
ROD END - ALWAYS PRESSURIZED - MUST
MAINTAIN EQUAL LENGTH AND DIAMETER
- Ⓓ HOSE ASSY 04
CAP END - MUST MAINTAIN EQUAL LENGTH
AND DIAMETER

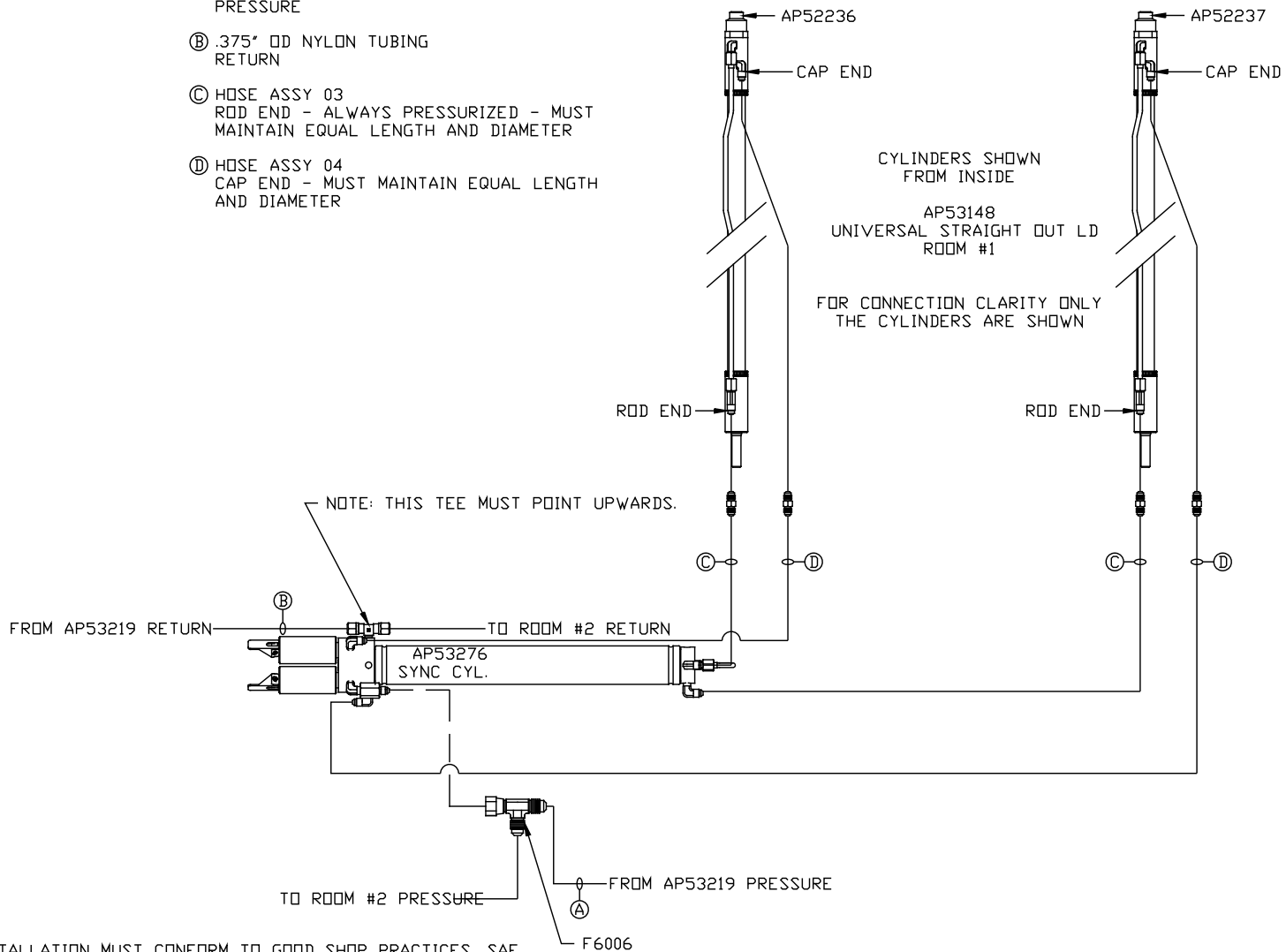

NOTE: INSTALLATION MUST CONFORM TO GOOD SHOP PRACTICES, SAE STANDARDS, RVIA STANDARDS, AND OTHER APPLICABLE STANDARDS.

- Ⓐ HOSE ASSY 04
PRESSURE
- Ⓑ .375" OD NYLON TUBING
RETURN
- Ⓒ HOSE ASSY 03
ROD END - ALWAYS PRESSURIZED - MUST
MAINTAIN EQUAL LENGTH AND DIAMETER
- Ⓓ HOSE ASSY 04
CAP END - MUST MAINTAIN EQUAL LENGTH
AND DIAMETER

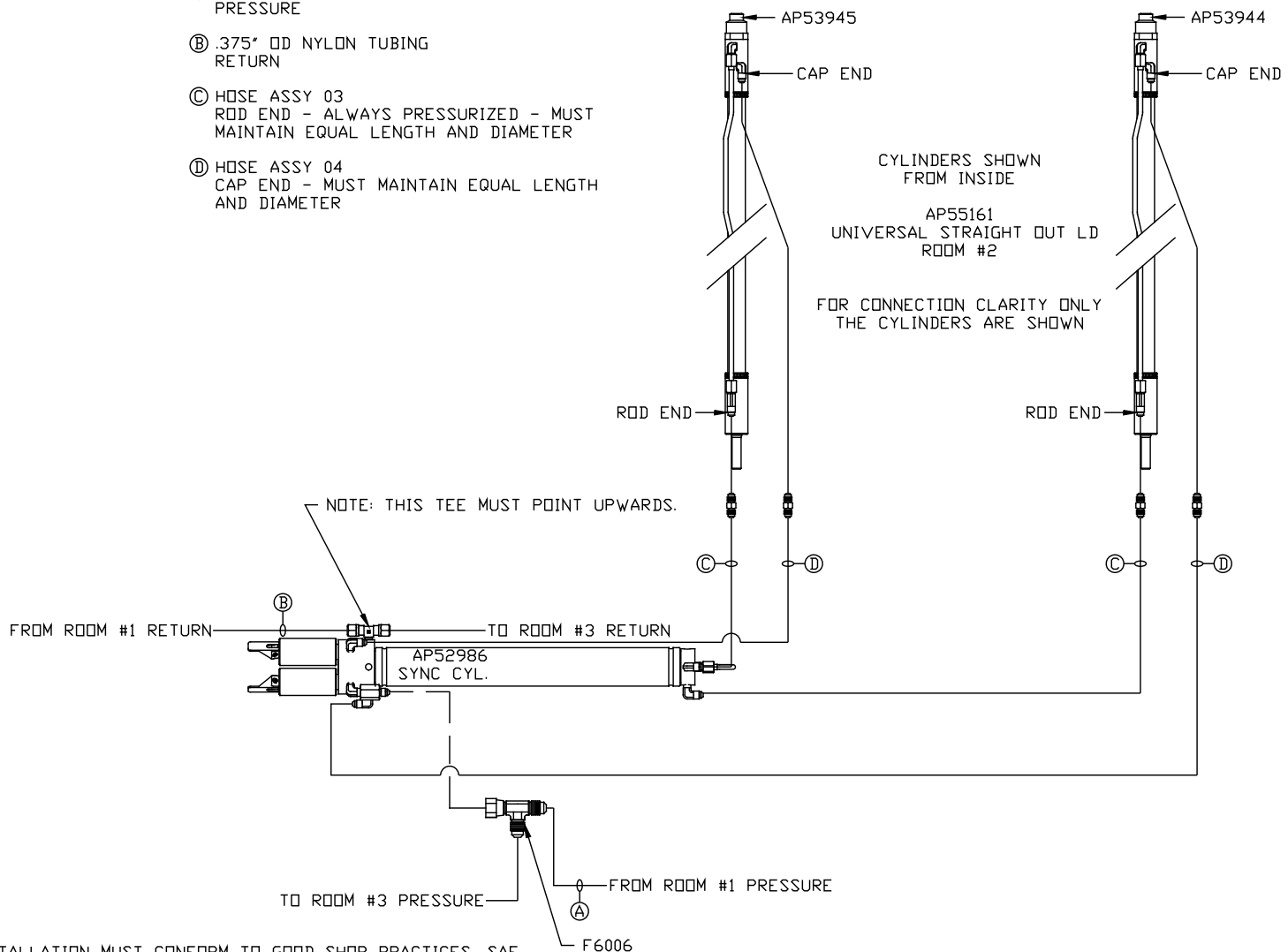

NOTE: INSTALLATION MUST CONFORM TO GOOD SHOP PRACTICES, SAE STANDARDS, RVIA STANDARDS, AND OTHER APPLICABLE STANDARDS.

- Ⓐ HOSE ASSY 04
PRESSURE
- Ⓑ .375" OD NYLON TUBING
RETURN
- Ⓒ HOSE ASSY 03
ROD END - ALWAYS PRESSURIZED - MUST
MAINTAIN EQUAL LENGTH AND DIAMETER
- Ⓓ HOSE ASSY 04
CAP END - MUST MAINTAIN EQUAL LENGTH
AND DIAMETER

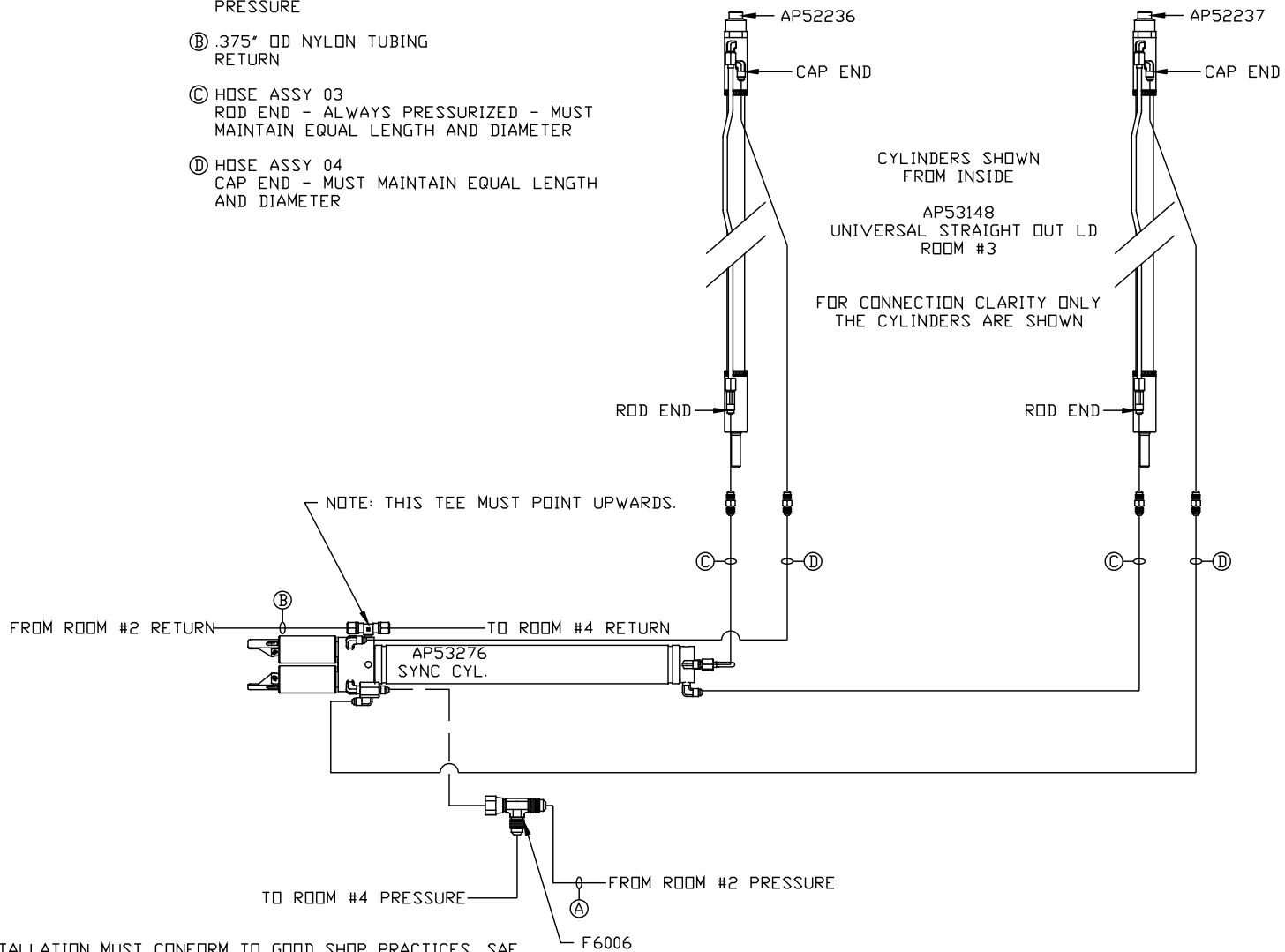

NOTE: INSTALLATION MUST CONFORM TO GOOD SHOP PRACTICES, SAE STANDARDS, RVIA STANDARDS, AND OTHER APPLICABLE STANDARDS.

- Ⓐ HOSE ASSY 04
PRESSURE
- Ⓑ .375" OD NYLON TUBING
RETURN
- Ⓒ HOSE ASSY 03
ROD END - ALWAYS PRESSURIZED - MUST
MAINTAIN EQUAL LENGTH AND DIAMETER
- Ⓓ HOSE ASSY 04
CAP END - MUST MAINTAIN EQUAL LENGTH
AND DIAMETER

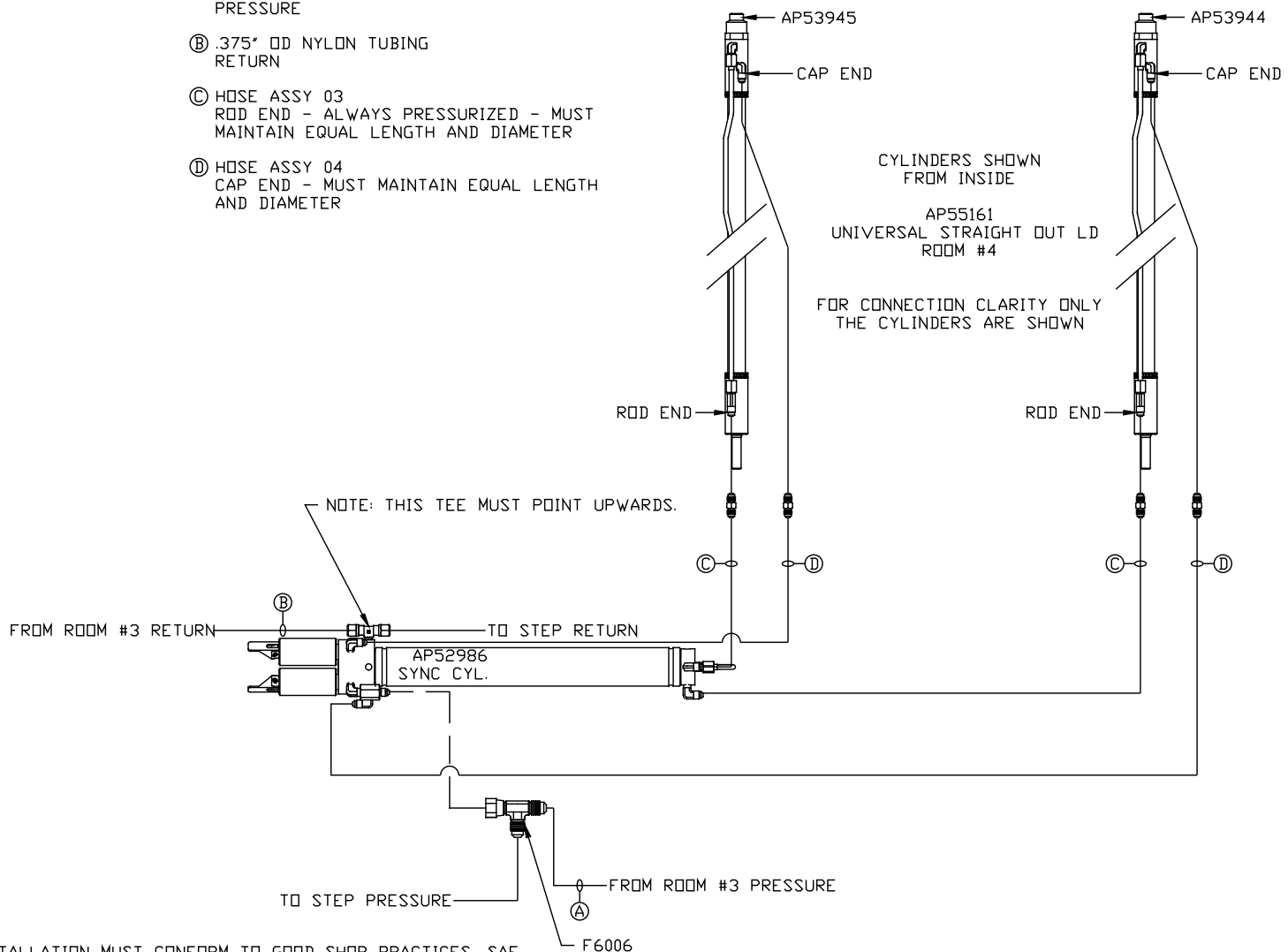

NOTE: INSTALLATION MUST CONFORM TO GOOD SHOP PRACTICES, SAE STANDARDS, RVIA STANDARDS, AND OTHER APPLICABLE STANDARDS.

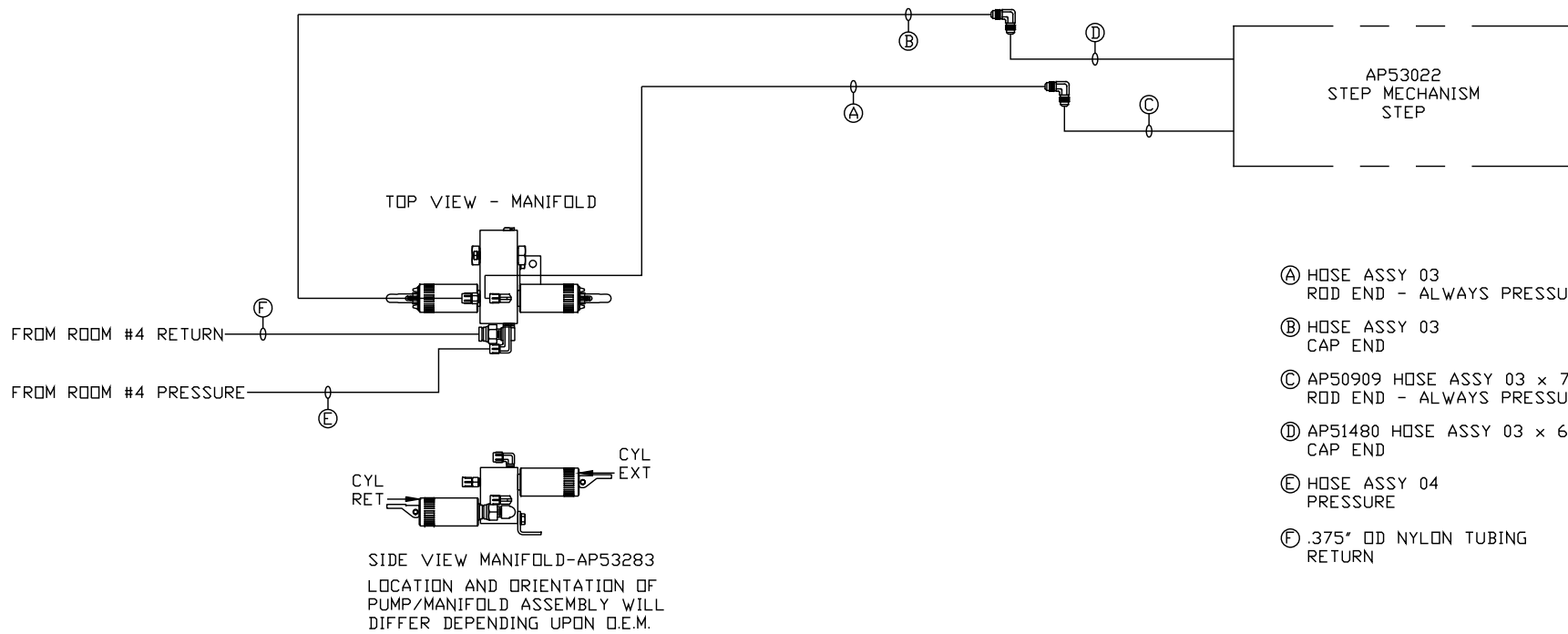

NOTE: INSTALLATION MUST CONFORM TO GOOD SHOP PRACTICES, SAE STANDARDS, RVIA STANDARDS, AND OTHER APPLICABLE STANDARDS.

MP70885 G/G
08JUN15