

- PIN
1. YELLOW CAN HIGH
  2. GREEN CAN LOW
  3. CAN SHIELD
  4. WHT(W6230) GROUND
  5. RED(W6800) SW. BATTERY

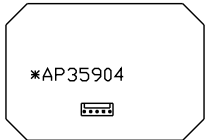

\*AP35904 IS PART OF AP34684

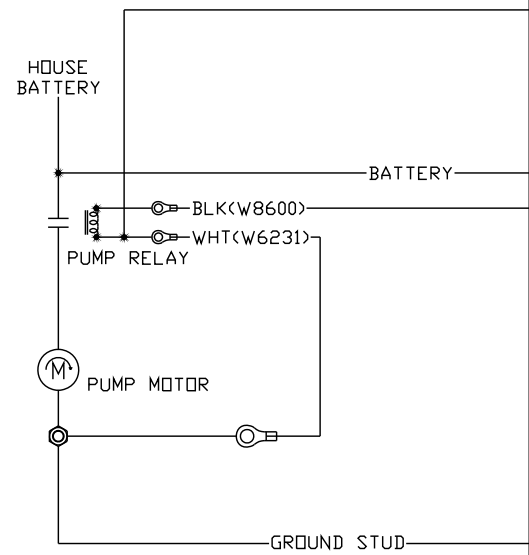
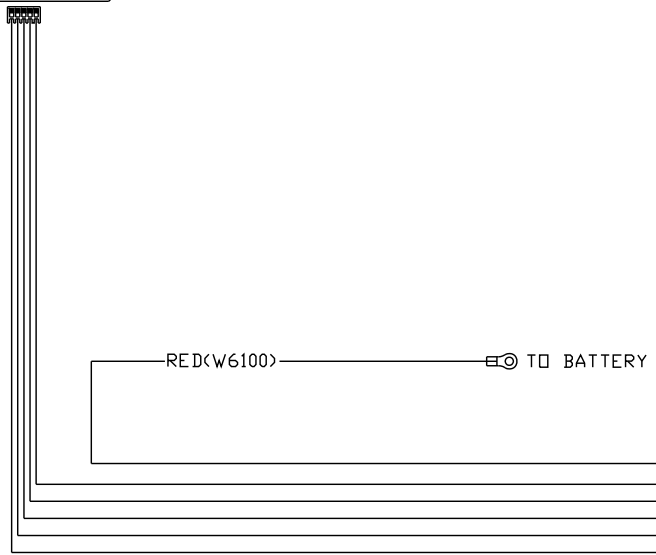

- RED(W6100)
- YELLOW
- GREEN
- SHIELD
- WHITE(W6230)
- RED(W6800)

NOTE: INSTALLATION MUST CONFORM TO GOOD SHOP PRACTICES, SAE STANDARDS, RVIA STANDARDS, AND OTHER APPLICABLE STANDARDS.

2	15NOV07	ADDED INSTALLATION NOTE
1	23NOV05	WAS AP34629, AP35128
NO.	DATE	REVISION
THE INFORMATION DISCLOSED ON THIS DRAWING IS CONFIDENTIAL AND MUST NOT BE DISCLOSED OR USED IN ANY MANNER WHICH WILL BE DETRIMENTAL TO THE HW H CORPORATION		

HW H I-80 EXIT 267 SOUTH  
RT 1 MOSCOW, IOWA 52760

SCALE 1:3 DATE 29JUL05 DRAWN BY .

SYSTEM SCHEMATIC ELEC

DRAWING NUMBER  
MP89514 A/D

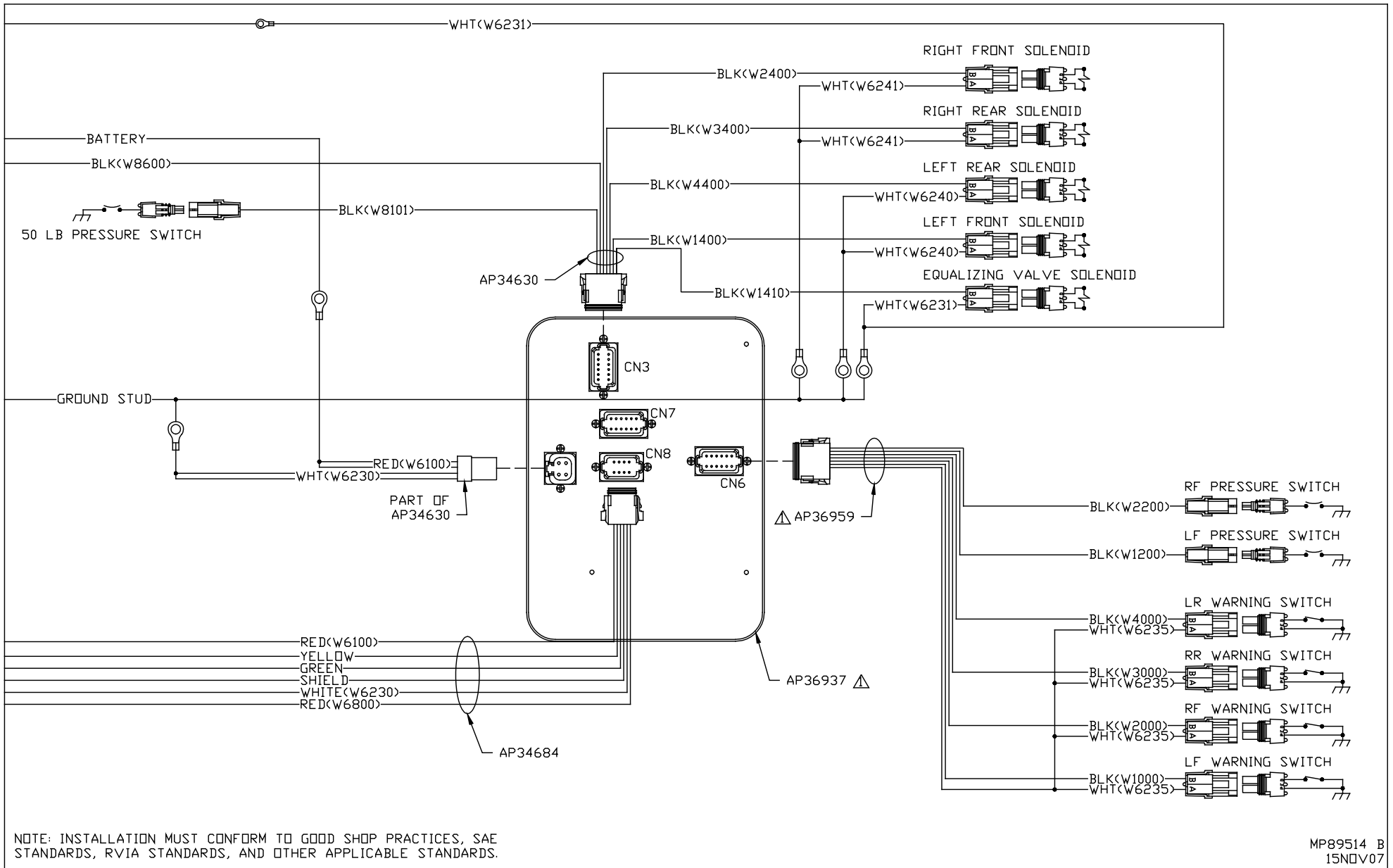

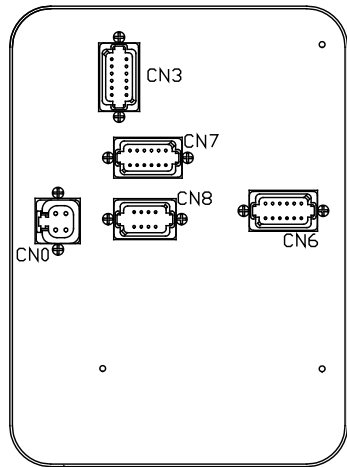

AP36937 ▲

CN3 (BROWN)  
PIN  
1 N/C  
2 N/C  
3 BLK(W810) 50 LB PRESS SW  
4 N/C  
5 BLK(W1400) LF SOLENOID  
6 N/C  
7 BLK(W1410) EQUALIZING SOLENOID  
8 BLK(W4400) LR SOLENOID  
9 BLK(W3400) RR SOLENOID  
10 BLK(W2400) RF SOLENOID  
11 N/C  
12 BLK(W8600) PUMP RELAY CONTROL

CN7 (BLACK)  
PIN  
1 N/C  
2 N/C  
3 N/C  
4 N/C  
5 N/C  
6 N/C  
7 N/C  
8 N/C  
9 N/C  
10 N/C  
11 N/C  
12 N/C

CN0 (GRAY)  
PIN  
1 RED(W6100) BATT  
2 RED(W6100) BATT  
3 WHT(W6230) GROUND  
4 WHT(W6230) GROUND

CN8 (BLACK)  
PIN  
1 N/C  
2 N/C  
3 RED(W6800) SW BATT  
4 WHT(W6230) GROUND  
5 CAN SHIELD  
6 RED(W6100) BATTERY  
7 GREEN  
8 YELLOW

CN6 (GRAY)  
PIN  
1 N/C  
2 N/C  
3 BLK(W1000) LF WARN SW  
4 BLK(W2000) RF WARN SW  
5 BLK(W1200) LF PRESS SW  
6 BLK(W2200) RF PRESS SW  
7 N/C  
8 N/C  
9 BLK(W3000) RR WARN SW  
10 BLK(W4000) LR WARN SW  
11 N/C  
12 WHT(W6235) GROUND

NOTE: WIRE NUMBERS ON THIS SHEET ARE REFERENCED TO HARNESS PLUGS.

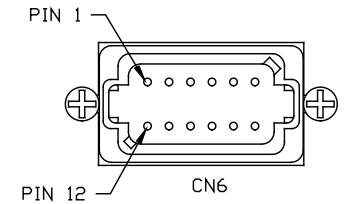
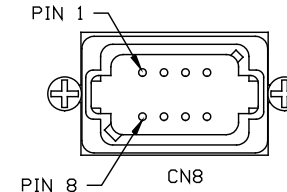
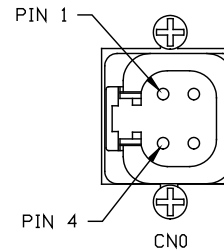
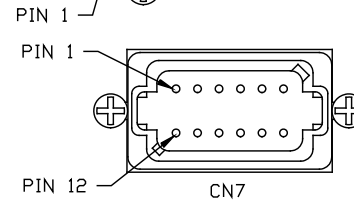
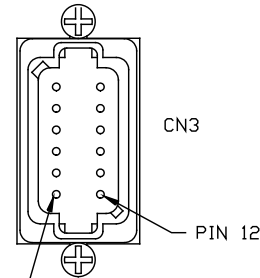

NOTE: INSTALLATION MUST CONFORM TO GOOD SHOP PRACTICES, SAE STANDARDS, RVIA STANDARDS, AND OTHER APPLICABLE STANDARDS.

MP89514 C  
15NOV07

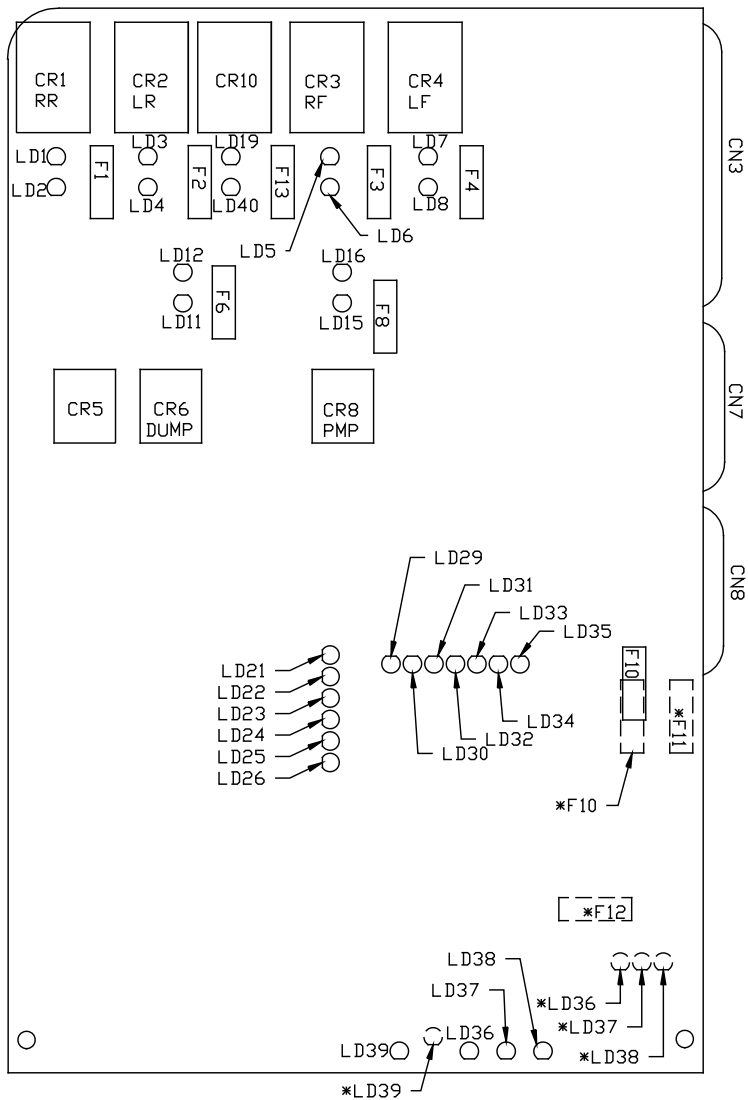

LED #	COLOR	DESCRIPTION
LED 1	YELLOW	RR COIL
LED 2	RED	RR CONTACT
LED 3	YELLOW	LR COIL
LED 4	RED	LR CONTACT
LED 5	YELLOW	RF COIL
LED 6	RED	RF CONTACT
LED 7	YELLOW	LF COIL
LED 8	RED	LF CONTACT
LED 11	YELLOW	DUMP COIL
LED 12	RED	DUMP CONTACT
LED 15	YELLOW	PUMP COIL
LED 16	RED	PUMP CONTACT
LED 19	YELLOW	EQ VALVE COIL
LED 21	YELLOW	LF WARN SW
LED 22	YELLOW	RF WARN SW
LED 23	YELLOW	RR WARN SW
LED 24	YELLOW	LR WARN SW
LED 25	RED	LF PRESS SW
LED 26	RED	RF PRESS SW
LED 29	RED	NOT USED
LED 30	YELLOW	NOT USED
LED 31	GREEN	NOT USED
LED 32	RED	MASTER WARNING CONTROL
LED 33	GREEN	50 LB PSW INPUT
LED 34	RED	JACK INTERRUPT
LED 35	RED	PARK BRAKE
LED 36	RED	BOARD ENABLED
LED 37	RED	ACCESSORY IN
LED 38	RED	ACCESSORY OUT
LED 39	RED	LINK LIGHT
LED 40	RED	EQ VALVE CONTACT

FUSE	RATING	DESCRIPTION
F1	15 AMP	RR OUTPUT
F2	15 AMP	LR OUTPUT
F3	15 AMP	RF OUTPUT
F4	15 AMP	LF OUTPUT
F6	5 AMP	DUMP
F8	5 AMP	PUMP OUTPUT
F10	7.5 AMP	ACC INPUT
*F11	3 AMP	WARN LITE SUPPLY
*F12	10 AMP	ACC OUTPUT
F13	15 AMP	EQ VALVE

NOTE: COMPONENTS MARKED WITH A "\*" ARE LOCATED ON OLDER 325 BOARD ASSEMBLIES.

ON NEWER BOARD ASSEMBLIES, FUSES F11 AND F12 HAVE BEEN REPLACED BY POLYFUSES. THESE POLYFUSES ARE NOT REPLACEABLE.

NOTE: INSTALLATION MUST CONFORM TO GOOD SHOP PRACTICES, SAE STANDARDS, RVIA STANDARDS, AND OTHER APPLICABLE STANDARDS.