

INSTALLATION SUPPLEMENT

210 JOYSTICK CONTROLLED - INTEGRATED CONTROL CONSOLE

SENSING UNIT ADJUSTMENT

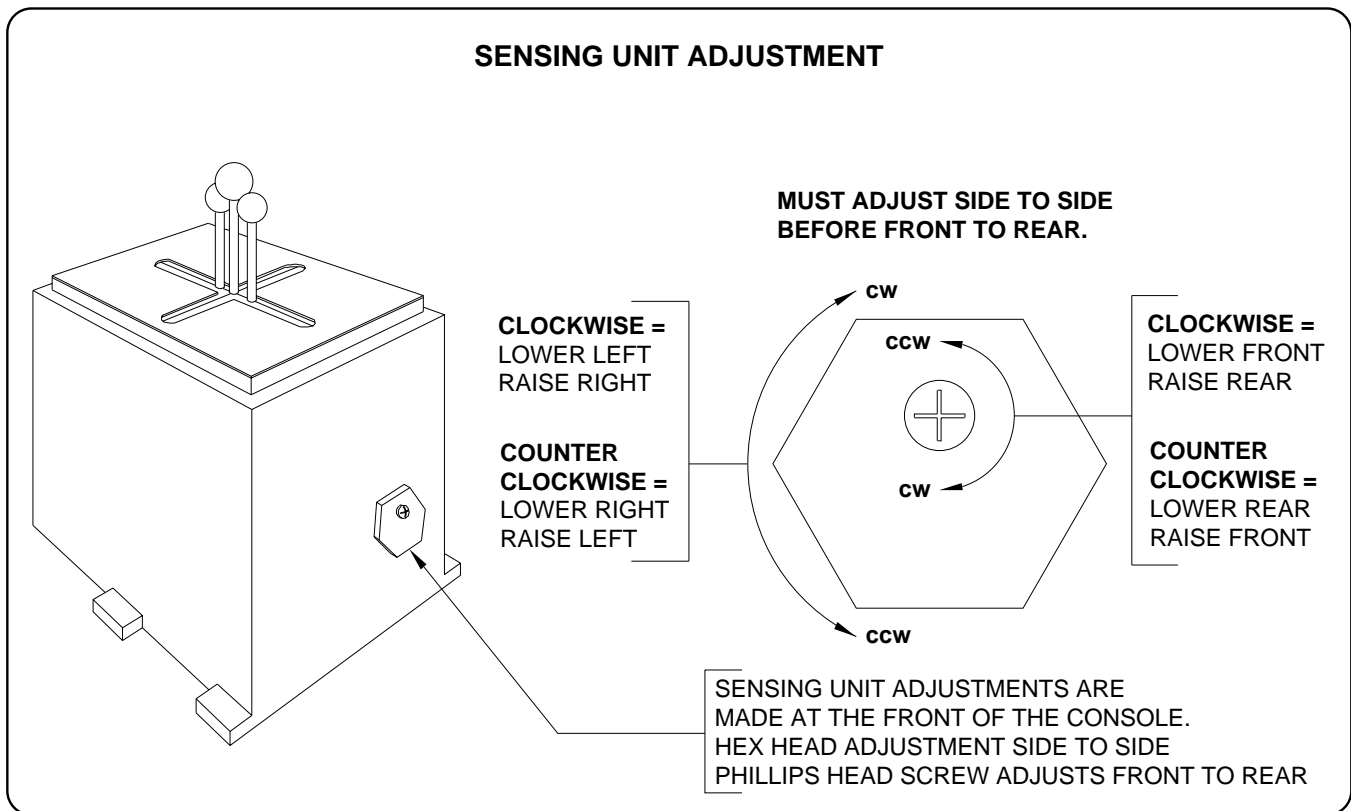

1. Level the coach according to a circular bubble level placed in the center of the freezer floor or in another location within the coach that is to be level.
2. The Sensing Unit adjustment is located on the front of the control console.
3. The sensing unit must be adjusted side to side before making front to rear adjustments. Side to side adjustment is made by turning the large hex head clockwise or counter clockwise until both yellow side lights are off.
 - A: If left side yellow light is on, turn hex Counter Clockwise until light turns off.
 - B: If right side yellow light is on, turn hex Clockwise until light turns off.
4. With both yellow side lights adjusted off, adjust front to rear if a front or rear light is on. Front to rear adjustment is made by turning the phillips head screw clockwise or counter clockwise until both yellow lights are off. (If a side light comes on it must be adjusted out before continuing with the front to rear adjustment.)
 - A: If front yellow light is on, turn screw Counter Clockwise until light turns off.
 - B: If rear yellow light is on, turn screw Clockwise until light turns off.
5. Repeat this procedure until all yellow lights are off. Tap hex head to see that the sensing unit has settled into the level position.