

INSTALLATION INSTRUCTIONS

STRAIGHT-ACTING, (POWER-EXTEND/SPRING-RETRACT) JACKS

FIFTH WHEEL 9000LB. REAR JACKS

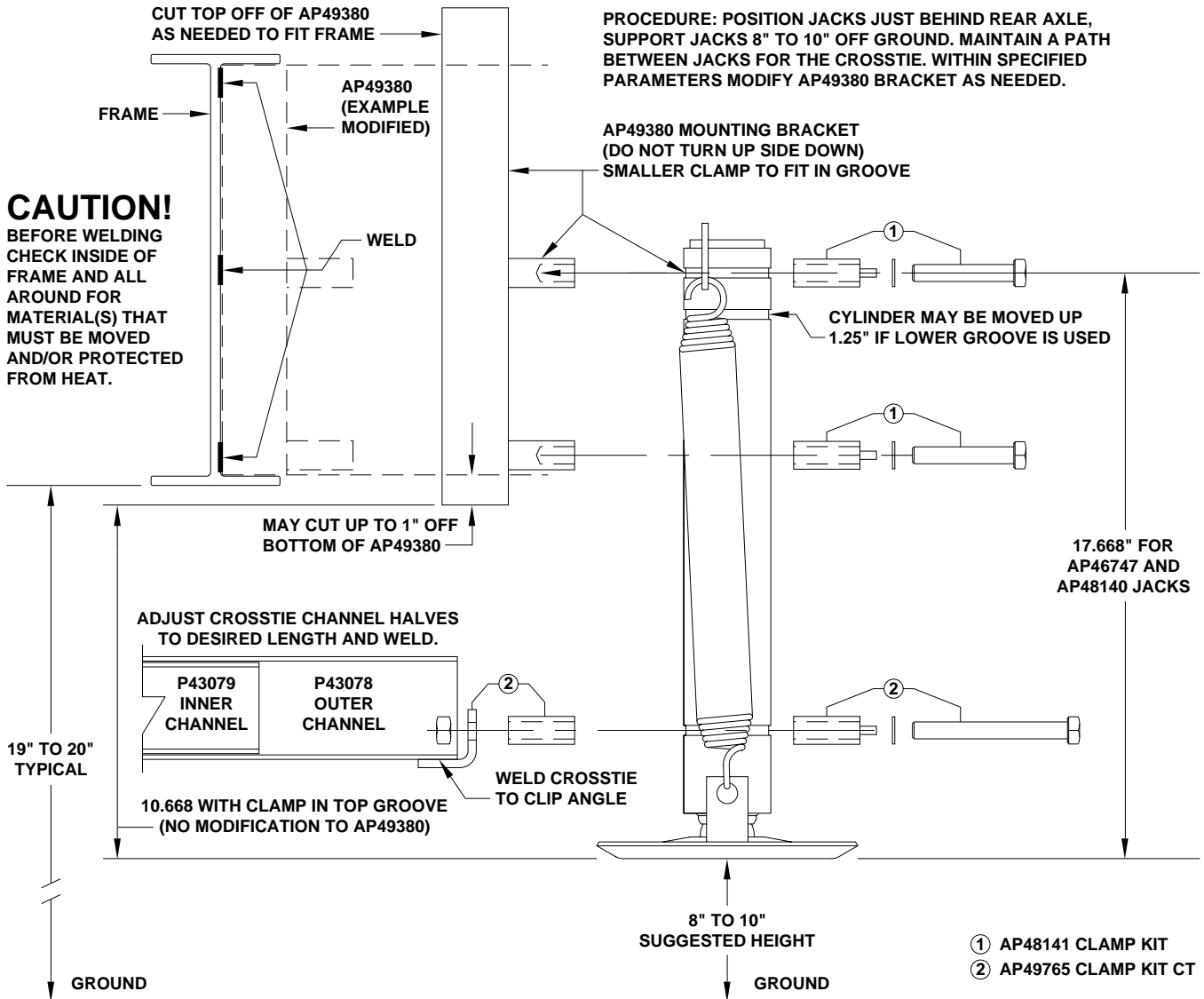

ALTERNATE BRACKET ARRANGEMENTS

AP49380 MOUNTING BRACKET MAY NEED TO BE OUTBOARD OF FRAME DUE TO OBSTRUCTIONS OR IF BOTTOM OF FRAME HEIGHT IS 21.5" OR GREATER AND 8" TO 10" MOUNTING HEIGHT CAN NOT BE ACHIEVED.

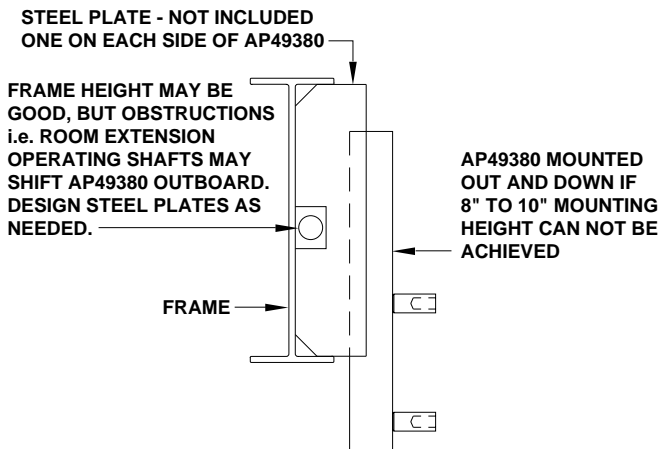

FRAME HEIGHT TOO LOW, 8" TO 10" MOUNTING HEIGHT CAN NOT BE ACHIEVED.

