

# Pivot Brkt Kit - 2 Jack Assy & 6,000# Cylinder Kit: Straight-Acting Jacks

**Application:** For mounting Straight-Acting Jacks on the FRONT OF CHEVY P30 chassis with a GVWR BETWEEN 14,800# AND 16,500# and the FRONT OF WORKHORSE P chassis with a GVWR BETWEEN 14,800# AND 18,000#

**Mfr. #:** AP16238 Pivot Brkt Kit - 2 Jack Assy P30F  
**Includes:** 1 - AP14915 Pivot Bracket Weldment P30  
 1 - AP0430 Hardware Kit  
**M.S.R.P.:** See Item Price Listing

**Mfr. #:** AP16236 Cylinder Kit  
**Includes:** 2 - AP16100 Cylinder 6,000 x 13  
 4 - Springs  
 2 - Feet  
 4 - Retaining Plates with Bolts  
**M.S.R.P.:** See Item Price Listing

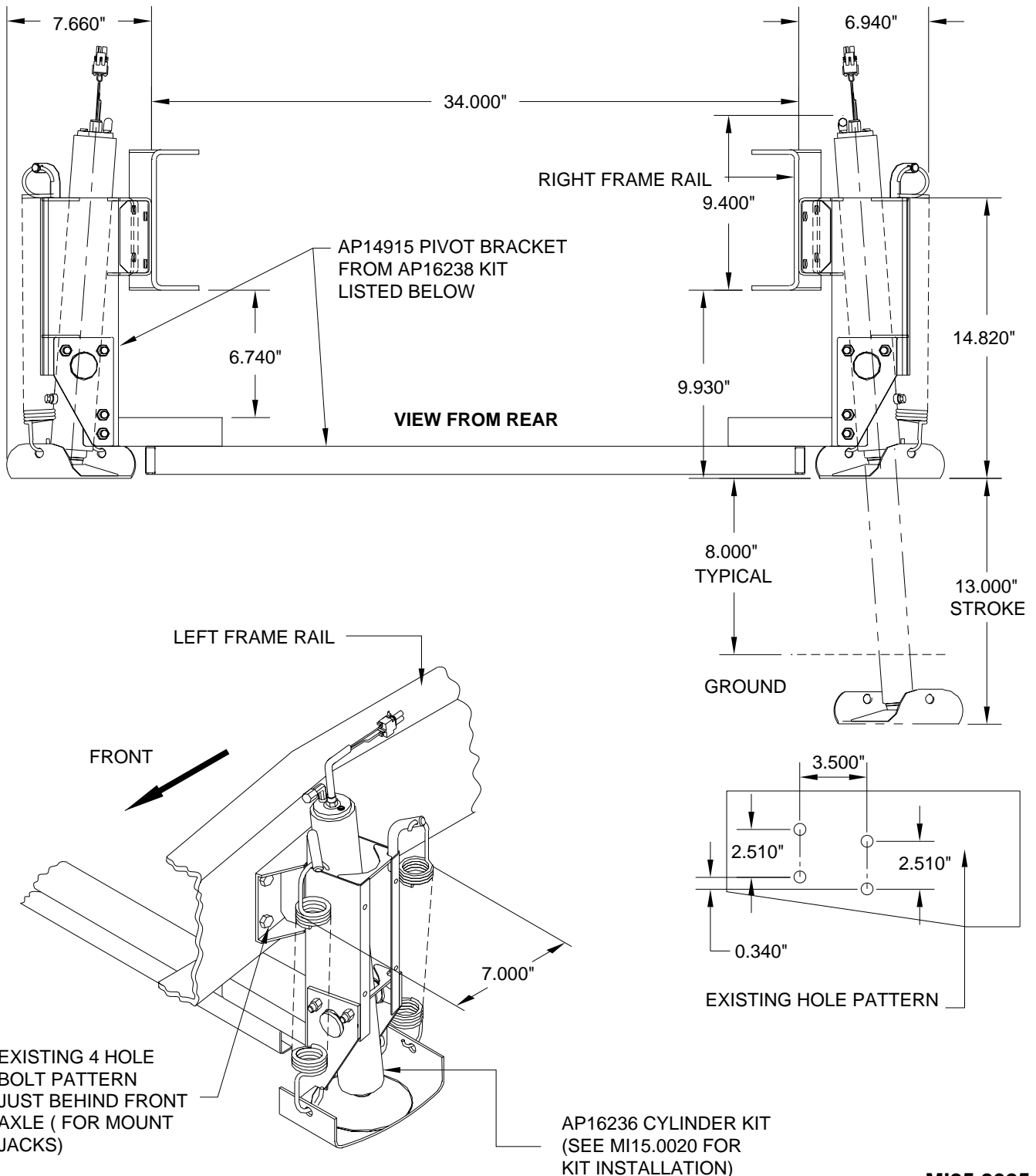

**CAUTION:** Follow CAUTIONS in Operator's and Installation Manuals concerning working under vehicles.

MI25.2025  
09JAN01