



OPERATOR'S MANUAL

HWH TOUCH PANEL-CONTROLLED 310 SERIES LEVELING SYSTEM

FEATURING:

*Touch Panel Control
Hydraulic Leveling
Kick-Down Jacks*

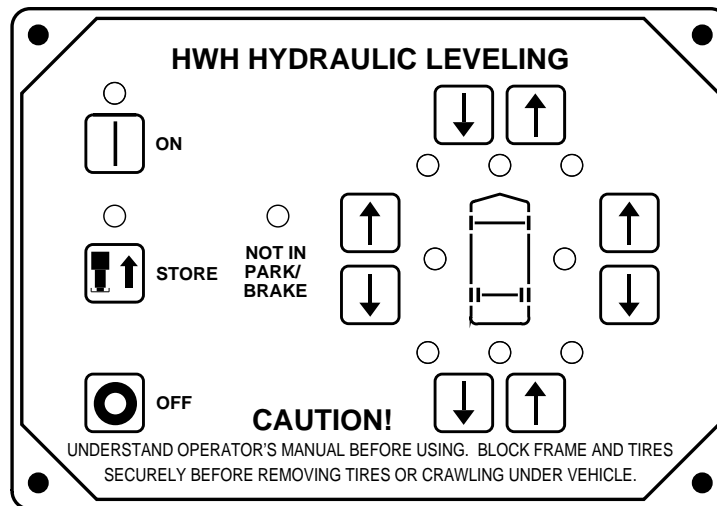

HWH CORPORATION

(On I-80, Exit 267 South)

2096 Moscow Road | Moscow, Iowa 52760

Ph: 800/321-3494 (or) 563/724-3396 | Fax: 563/724-3408

www.hwh.com

**AP10041 - U.S.
AP10300 - Europe
AP21655 - French**

**ML10041/MP05.3002/LH-K
28AUG02**

OPERATOR'S MANUAL

CAUTION !

READ THE ENTIRE OPERATOR'S MANUAL BEFORE OPERATING.

BLOCK FRAME AND TIRES SECURELY BEFORE CRAWLING UNDER VEHICLE. DO NOT USE LEVELING JACKS OR AIR SUSPENSION TO SUPPORT VEHICLE WHILE UNDER VEHICLE OR CHANGING TIRES. VEHICLE MAY DROP AND OR MOVE FORWARD OR BACKWARD WITHOUT WARNING CAUSING INJURY OR DEATH.

KEEP ALL PEOPLE CLEAR OF THE VEHICLE WHILE LEVELING SYSTEM AND ROOM EXTENSIONS ARE BEING OPERATED.

KICK-DOWN JACKS MAY ABRUPTLY SWING UP WHEN THE FOOT OF THE JACK CLEARS THE GROUND OR WHEN THE JACK REACHES FULL EXTENSION.

NEVER PLACE HANDS OR OTHER PARTS OF THE BODY NEAR HYDRAULIC LEAKS. OIL MAY PENETRATE THE SKIN CAUSING INJURY OR DEATH.

WEAR SAFETY GLASSES WHEN INSPECTING OR SERVICING THE SYSTEM TO PROTECT EYES FROM DIRT, METAL CHIPS, OIL LEAKS, ETC. FOLLOW ALL OTHER APPLICABLE SHOP SAFETY PRACTICES.

IF THE VEHICLE IS EQUIPPED WITH KICK-DOWN STYLE JACKS, DO NOT OVER EXTEND THE REAR JACKS. IF THE WEIGHT OF THE VEHICLE IS REMOVED FROM ONE OR BOTH REAR WHEELS, THE VEHICLE MAY ROLL FORWARD OR BACKWARD OFF OF THE JACKS.

NOTE: KEEP THE CONTROL VALVE LEVERS IN THE STORE POSITION WHEN JACKS ARE NOT IN USE.

IMPORTANT: IF VEHICLE IS EQUIPPED WITH A ROOM EXTENSION, READ ROOM EXTENSION SECTION BEFORE OPERATING LEVELING SYSTEM.

HOW TO OBTAIN WARRANTY SERVICE

THIS IS NOT TO BE INTERPRETED AS A STATEMENT OF WARRANTY

HWH CORPORATION strives to maintain the highest level of customer satisfaction. Therefore, if you discover a defect or problem, please do the following:

FIRST: Notify the dealership where you purchased the vehicle or had the leveling system installed. Dealership management people are in the best position to resolve the problem quickly. If the dealer has difficulty solving the problem, he should immediately contact the Customer Service Department, at HWH CORPORATION.

SECOND: If your dealer cannot or will not solve the problem, notify the Customer Service Department:
HWH CORPORATION 2096 Moscow Rd. Moscow IA. 52760
(563) 724-3396 OR (800) 321-3494. Give your name and address, coach manufacturer and model year, date the coach was purchased, or the date of system installation,

description of the problem, and where you can be reached during business hours (8:00 a.m. till 5:00 p.m. c.s.t.). HWH CORPORATION personnel will contact you to determine whether or not your claim is valid. If it is, HWH CORPORATION will authorize repair or replacement of the defective part, either by appointment at the factory or by the authorization of an independent service facility, to be determined by HWH CORPORATION. All warranty repairs must be performed by an independent service facility authorized by HWH CORPORATION, or at the HWH CORPORATION factory, unless prior written approval has been obtained from proper HWH CORPORATION personnel.

CONTROL IDENTIFICATION

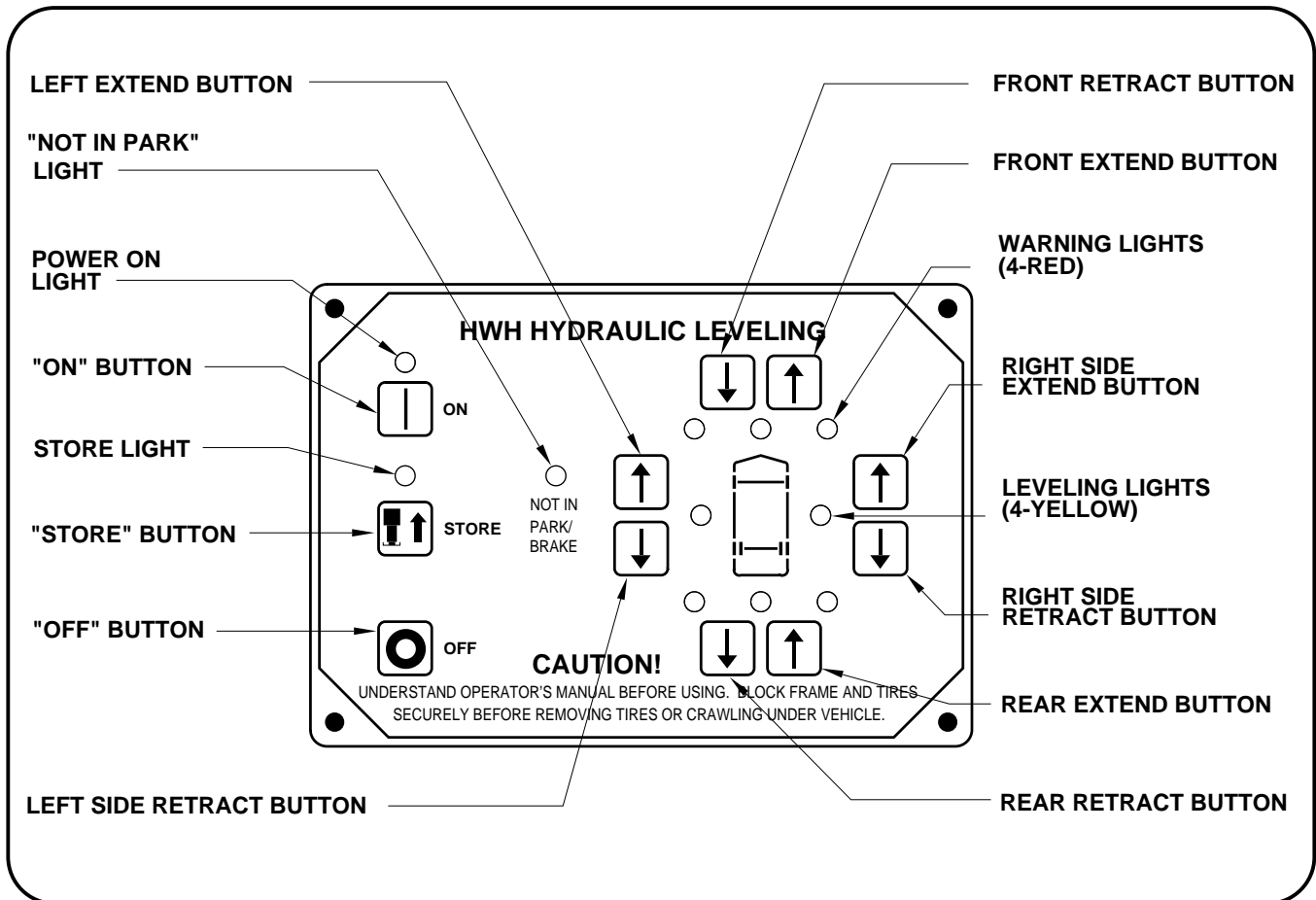

CONTROL FUNCTIONS

CONTROL BUTTONS

"ON" BUTTON : This is the "ON" button for the leveling system. It provides control power to operate the electrical relay on the pump, the leveling lights and the 4 red warning lights.

"OFF" BUTTON : This button turns off control power to the leveling system.

"STORE" BUTTON : This button will retract all four jacks at the same time.

EXTEND BUTTONS (UP ARROWS) : These buttons will extend their respective jack pairs to lift the vehicle.

RETRACT BUTTONS (DOWN ARROWS) : These buttons will retract their respective jack pairs to lower the vehicle.

INDICATOR LIGHTS

POWER ON LIGHT : This light indicates the system is on.

STORE LIGHT : This light will be on when the system is in the store mode.

NOT IN PARK/BRAKE LIGHT : This indicator light is on when the panel is on, but the hand/auto park brake is not set.

LEVELING LIGHTS : If a yellow LEVELING LIGHT is on, that indicates a side or end of the vehicle is low. Extend the appropriate jack pairs to put out the yellow light. Only one yellow leveling light can be on at a time. The vehicle is level when all yellow lights are out.

"WARNING LIGHTS" : A red "WARNING" light will be on whenever the corresponding jack is in the vertical position, provided the ignition switch is in the "ACC" or "ON" position and the system is on. Some vehicles are equipped with a dash mounted master "JACKS DOWN" light which will be on when one or more jacks are vertical, provided the ignition switch is "ON".

OPERATING PROCEDURES

SITE SELECTION

Maintain adequate clearance in all directions for vehicle, room extensions, awnings, doors, steps, ect. Vehicle may move in any direction due to jacks extending or retracting, settling of jacks or vehicle, equipment malfunction, ect. Park with the front of the vehicle facing downhill if possible.

Care must be taken not to raise the rear of the vehicle too high or the vehicle may roll forward or backward off the jacks. If parking on soft ground or asphalt paving, wood blocks or pads should be placed under the jacks.

ROOM EXTENSION PROCEDURES

IMPORTANT: If the vehicle is equipped with a room extension read this section carefully.

Refer to the vehicle owners manual for proper operation of room extensions.

If the vehicle is equipped with kick-down jacks, the wheels MUST be blocked securely. It is recommended to complete the Leveling Procedure before operating room extensions. It is recommended to retract room extensions before retracting jacks.

IMPORTANT: Do not use a room extension support when the vehicle is supported by the leveling system.

LEVELING PROCEDURE

1. Place gear selector in the parking position, apply park brake and block tires securely.

NOTE: If the hand/auto park brake is not set, the "NOT IN PARK/BRAKE" light will come on when the "ON" button is pushed. The panel will turn on, but the system will not operate.

2. Turn ignition switch to "ON" or "ACCESSORY".

3. Push the "ON" button on the touch panel. The POWER ON light will be lit. Place pads under the jacks, if necessary, at this time.

4. Swing the jacks to the vertical position by pushing the front EXTEND (up arrow) button until the two front red WARNING lights come on. Then push the rear EXTEND (up arrow) button until the two rear red WARNING lights are on. Check that all jacks have swung to the vertical position. Place a pad under each jack, if necessary, at this time.

5. A lit yellow LEVEL light indicates that the end, side, or corner is low. Push the EXTEND (up arrow) button to extend jack pairs according to a lit yellow light. ALWAYS LEVEL THE

VEHICLE FROM SIDE TO SIDE IF NECESSARY BEFORE LEVELING THE VEHICLE FROM FRONT TO REAR. Only one yellow LEVEL light can be on at one time. Extend jack pairs accordingly until all yellow lights are out. If the ground is too uneven, the jack may not have enough stroke to level the vehicle. The vehicle may have to be moved. REMEMBER, if lifted too high, the vehicle may roll forward or backward off the jacks.

6. After the vehicle is level, the jacks not used for leveling may be extended until they touch the ground and lift the vehicle slightly. This provides additional stability against wind and activity in the vehicle. Do this by pushing the front and/or rear EXTEND buttons as needed to extend any remaining jacks. Do not use the right or left EXTEND buttons.

7. Push the "OFF" button on the touch panel.

8. Turn the ignition switch off.

OPERATING PROCEDURES

JACK RETRACT PROCEDURES

IMPORTANT : Do not retract the leveling system until all rooms are fully retracted.

CAUTION: THE OPERATOR MUST BE SURE THAT THERE ARE NO OBJECTS UNDER THE VEHICLE AND THAT ALL PEOPLE ARE CLEAR OF THE VEHICLE.

1. Turn the ignition switch "ON" and press the "ON" button one time. The ON indicator light will glow steady.
2. Press the "STORE" button. As each jack retracts, its red WARNING light will go out. The vehicle can be moved as soon as the red WARNING lights are out, provided the jacks are in the STORE/TRAVEL position.

IMPORTANT: DO NOT interrupt power to the leveling system while it is in the STORE mode. DO NOT push the "OFF" button or turn the ignition key. The system must be allowed to completely finish the STORE mode. If the engine was started before putting the system in the STORE mode, the vehicle may be moved when the jacks are in the "STORE" position. This will not interrupt the store procedure.

CAUTION: DO NOT RELY SOLELY UPON THE WARNING INDICATORS. IT IS THE OPERATOR'S RESPONSIBILITY TO CHECK THAT ALL JACKS ARE IN THE STORE/TRAVEL POSITION BEFORE MOVING THE VEHICLE.

3. The system will automatically shut down approximately two minutes after the four individual red WARNING lights are out.

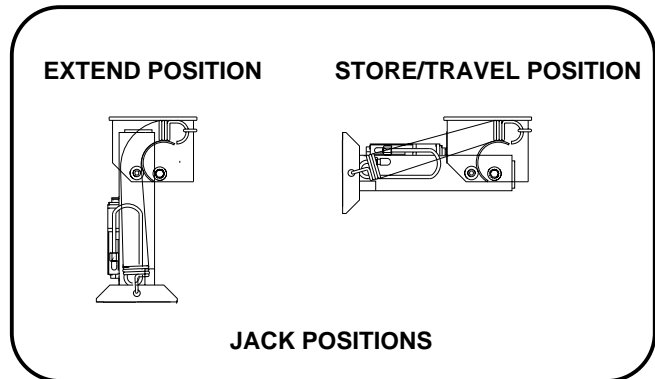

IMPORTANT: If any one red WARNING light does not go out the system will continue to store. Push the "OFF" button and have the system serviced.

4. Turn the ignition switch to the "OFF" position or proceed to travel.

NOTE: If jacks cannot be retracted by the above procedure see MANUAL JACK RETRACTION Section.

NOTE: If the vehicle is parked or stored with the jacks extended for an extended period of time and the jacks fail to retract completely, extend the jacks back down to the ground then retract the jacks again.

MANUAL JACK RETRACTION

NOTE : Use the valve release "T" handles for retracting only if the "STORE" button on the control panel will not retract the jacks for travel.

CAUTION: KEEP AWAY FROM THE WHEELS, DO NOT CRAWL UNDER THE VEHICLE, KEEP A SAFE DISTANCE IN FRONT AND REAR OF VEHICLE. THE VEHICLE MAY DROP AND/OR MOVE FORWARD OR BACKWARD WITHOUT WARNING AS THE VALVE RELEASE IS OPERATED.

1. Locate the 4 valve release "T" handles on the solenoid valves. The solenoid valves are located on the pump/valve assembly.
2. Allow clearance for vehicle to lower.
3. Retract the rear jacks by opening the two outer valves. Slowly turn the "T" handles counter clockwise. The handles may turn easily at first but as an internal spring is compressed, turning may become more difficult. The valves need only to be opened enough to retract the jack.

4. Retract the front jacks by opening the two center valves as described in Step 3.

5. Check that all four jacks are now retracted.

6. Close the valves by turning the release handles clockwise.

Once the internal spring tension has been released, the handles will turn free for several turns. Once the "T" handles are snug, DO NOT tighten the handles past this point as internal damage may occur to the solenoid.

7. The system should now be repaired before using again.

MAINTENANCE

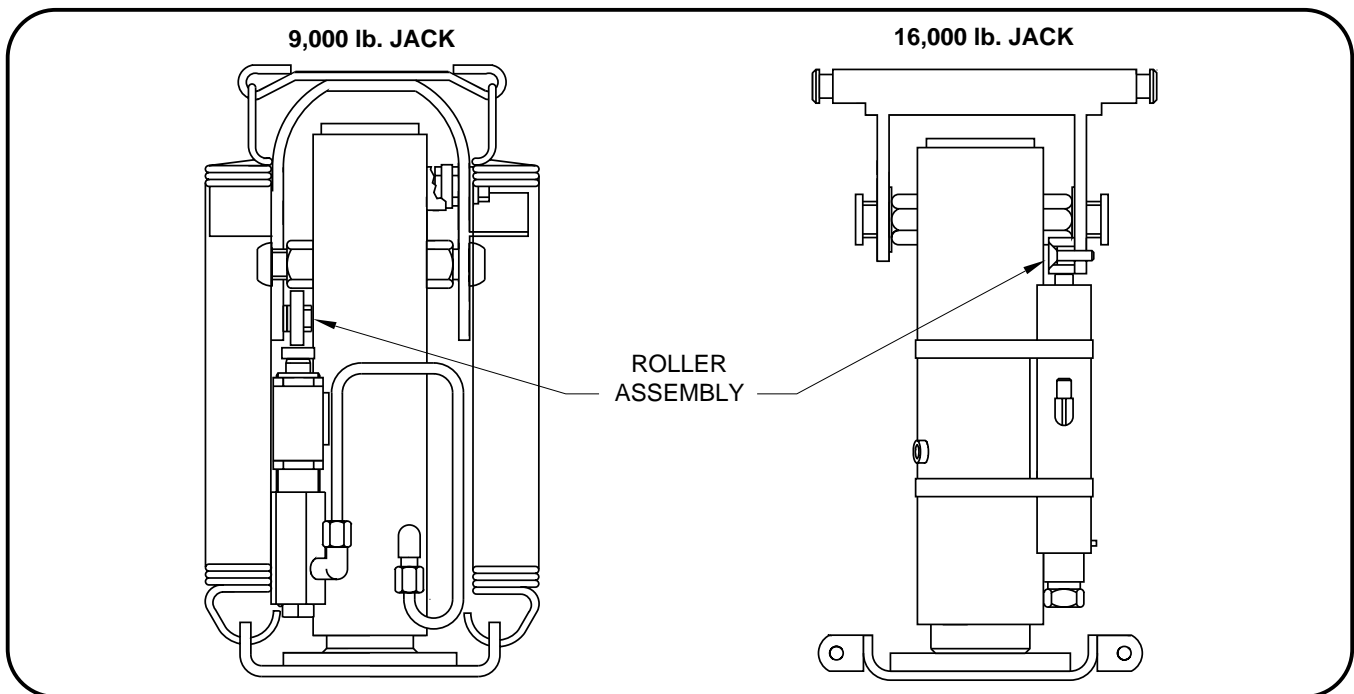

FLUID LEVELS

It is important that all of the jacks are fully retracted before checking the hydraulic oil level. To check the oil supply, remove the breather cap from the top of the hydraulic oil reservoir. The oil level should be approximately one inch below the top of the reservoir when adequately filled.

FLUID: HWH Specialty Hydraulic Oil is recommended. In an emergency Dexron automatic transmission fluid can be used.
NOTE: Dexron automatic transmission fluid contains red dye and can cause staining should a leak occur. **DO NOT USE** brake fluid or hydraulic jack fluid. Use of these can damage seals.

JACK MAINTENANCE

On the 9,000 lb. jacks and the 16,000 lb. jacks there are roller assemblies that need to rotate freely. (See above FIGURE) These rollers should be cleaned with a penetrating fluid, such as WD-40, and lubricated with a light oil as part of your regular maintenance schedule.

In general, to insure the smooth operation of the leveling system, it is a good idea to occasionally check the individual leveling jacks to prevent problems. This is especially true under the unusual conditions stated in the following:

UNUSUAL CONDITIONS

If driving conditions are unusually muddy, the jacks may become caked or clogged with mud. This condition may hamper the proper operation of the leveling system. This problem may be prevented or remedied by cleaning off each leveling jack if they become excessively muddy.

Do not move the vehicle while the leveling jacks are still in contact with the ground. However, if this should accidentally happen, the leveling system was designed to protect itself from damage in most cases. Place the system in the STORE mode and then visually check to see if the leveling jacks have returned to the STORE/TRAVEL POSITION.

In wet or icy weather leveling jacks may become encrusted with ice. This may cause the leveling system to function improperly. To eliminate this problem, periodically check the leveling jacks and break loose any ice which may be causing improper operation.

NOTE: All major components of the system can be replaced with rebuilt parts or can be sent to HWH CORPORATION to be rebuilt, when the system is out of warranty.

ELECTRICAL SYSTEM

The batteries should be in good condition and fully charged. Weak batteries can cause erratic operation. Battery cable terminals and battery posts and connections should be kept

clean. All electrical connections, especially ground connections, should be clean, tight, free from corrosion and protected from weathering.

MAINTENANCE

SYSTEM ADJUSTMENT

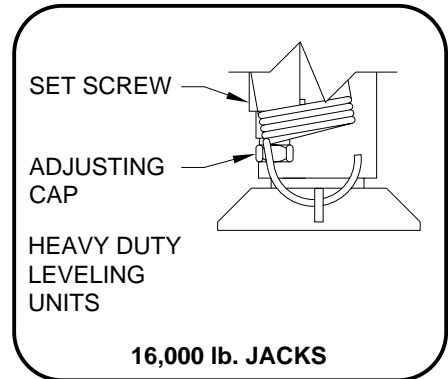
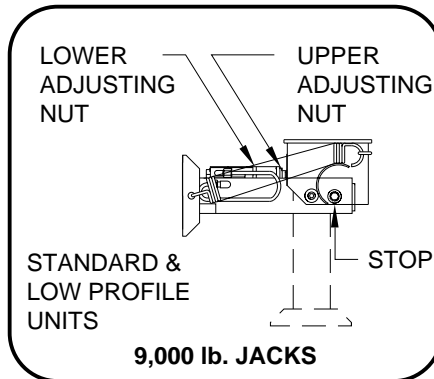
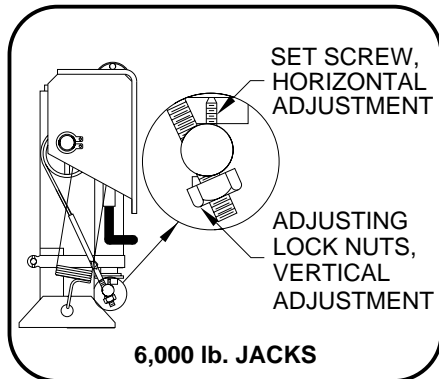

JACK ADJUSTMENT

There are two basic adjustments which are made at the time of installation. However, when adjustment of a leveling unit is needed, the following procedures are recommended.

1. 6,000 lb. JACKS: Always make vertical adjustment first. If the vertical adjustment is changed at anytime, be sure to check the horizontal adjustment. Vertical position is changed by adjusting the lock nuts on the actuator cable. If the jack stopped short of vertical, tighten the lock nuts. If the jack goes past vertical, back the lock nuts off. Be sure to adjust each nut the same number of turns.

NOTE: The two front jacks should be adjusted to the same horizontal position.

Horizontal stop is adjusted by turning the set screws located just inside the cable locknuts. The jack can be adjusted down to provide clearance for objects which may interfere with the operation of the jacks. The horizontal stop must be adjusted to provide clearance between the hat bracket and mounting bolts; and the actuator and hose fittings, when the jack is in the STORE POSITION. The jack must be able to fully extend in the horizontal position without interfering with suspension components, tanks, etc.

2. 9,000 lb. JACKS: Each jack should be checked to be sure that it is vertical when it swings down. To do this, retract all jacks, then extend each jack until it is close to, but not touching the ground. If the jack stopped short of being vertical, it can be adjusted by loosening the lower adjusting nut and tightening the upper nut.

The horizontal stop can be adjusted up or down in the slot to provide clearance for objects which may interfere with operation of the jack. The stop must be adjusted so that the jack can be fully extended in the horizontal position without interfering with suspension components, tanks, etc.

3. 16,000 lb. JACKS: If the jack stopped short of being vertical loosen the set screw and turn the adjusting cap clockwise. If the jack went beyond vertical, loosen the set screw and turn the adjusting cap counterclockwise. After each adjustment, the weight of the vehicle must be applied to the jack to make the adjustment effective. DO NOT adjust cap more than one turn without cycling the jack.

The horizontal stop on the heavy-duty jack is adjusted by adding washers under the urethane stop.

LEVEL SENSING UNIT ADJUSTMENT

Level the vehicle by placing a circular bubble level in the center of the freezer floor or location within the vehicle that is to be level. With the vehicle level, adjust the sensing unit until all yellow lights are off. This is done by drawing up the corresponding screw if the sensing unit is mounted below the surface as shown or backing out the corresponding screw if the sensing unit is mounted above the surface. Bump the sensing unit to see that it is settled tight against all three screw heads and still indicates that the unit is level.

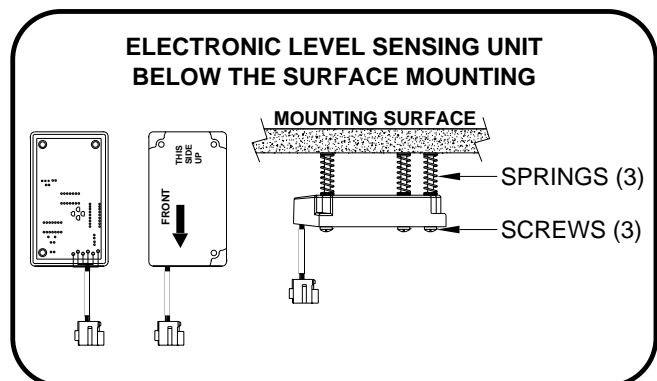

TROUBLE SHOOTING LEVELING SYSTEM

The following is a list of problems, and possible solutions, which might occur to the leveling system.

NOTE : Only qualified technicians should install or repair leveling systems on coaches. A knowledge of hydraulics, welding, the vehicle's suspension and electrical system, as well as an understanding of the leveling system's hydraulics and electronics is required.

1. JACK RETRACTS AFTER COACH IS LEVEL.

- A. Hose or jack has external leak.
- B. Fluid is leaking back to reservoir through solenoid valve.

2. LEVELING JACKS WILL NOT RETRACT COMPLETELY.

- A. Actuator rod bent or scored (rod will not move freely).
- B. Jack clogged with mud or ice.
- C. Main rod bent or scored.
- D. Springs weak or broken.
- E. Hydraulic line pinched.

3. UNIT IS EXTENDED BUT NOT VERTICAL.

- A. Roller assembly frozen or missing.
- B. Actuator rod bent.
- C. Actuator not functioning properly.

4. IGNITION SWITCH ON, BUT NO POWER TO PUMP AND/OR LIGHTS.

- A. Park brake not set.
- B. 12 volts from main power source not present.
- C. Faulty control box.
- D. Faulty wire or electrical connection.

5. PUMP WILL NOT ACTIVATE.

- A. Bad touch panel.
- B. Bad control box.
- C. Pump relay not functioning.
- D. Pump not grounded.

6. HYDRAULIC PUMP ACTIVATES, BUT THE JACKS WILL NOT EXTEND.

- A. Bad solenoid valve.
- B. Bad manifold pressure switch.
- C. Oil supply low in reservoir.
- D. Pump is not developing pressure.
- E. Broken hydraulic line.
- F. Bad control box.
- G. Bad shuttle valve.

7. LEVELING LIGHTS (YELLOW) NOT FUNCTIONING PROPERLY.

- A. Yellow lights will not go out when vehicle is level: adjust sensing unit.
- B. If more than two yellow lights are on, replace the sensing unit.

8. WARNING LIGHTS (RED) NOT FUNCTIONING PROPERLY.

- A. Light will not come on: check for broken wire at warning switch on the jack.
- B. Lights will not go out bad warning switch or wires are shorted to ground.
- C. Check the touch panel.

HYDRAULIC LINE CONNECTION DIAGRAM LEVELING SYSTEM



FRONT

NOTE: BEFORE OPERATING VALVE RELEASE "T" HANDLES, READ AND UNDERSTAND PROCEDURE FOR MANUAL JACK RETRACTION IN OPERATOR'S INSTRUCTIONS.

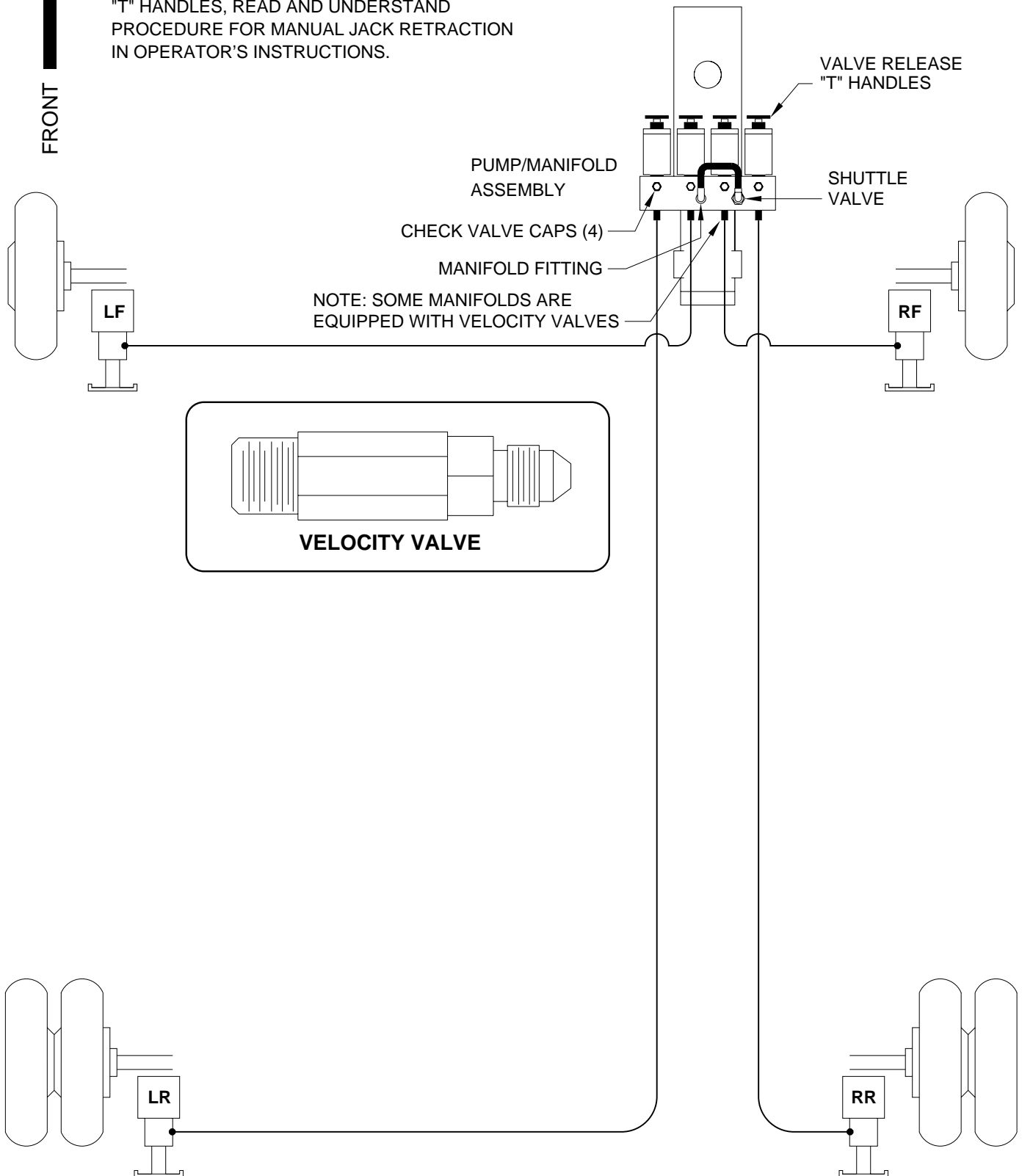

HYDRAULIC SCHEMATIC

305/310/325 SERIES, TOUCH PANEL-CONTROLLED LEVELING SYSTEM WITH KICK-DOWN JACKS

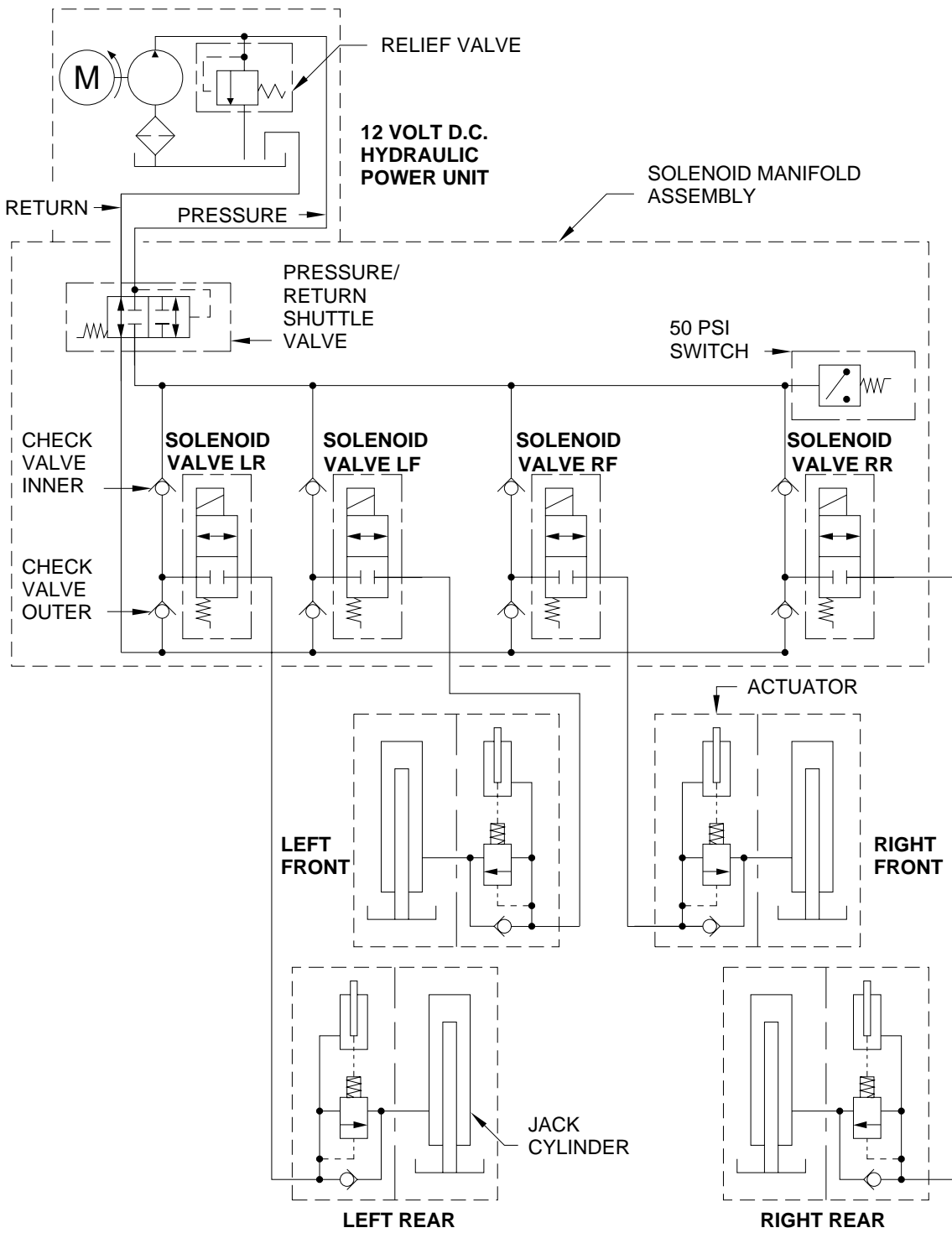

310 LEVELING SYSTEM ELECTRICAL CONNECTION DIAGRAM

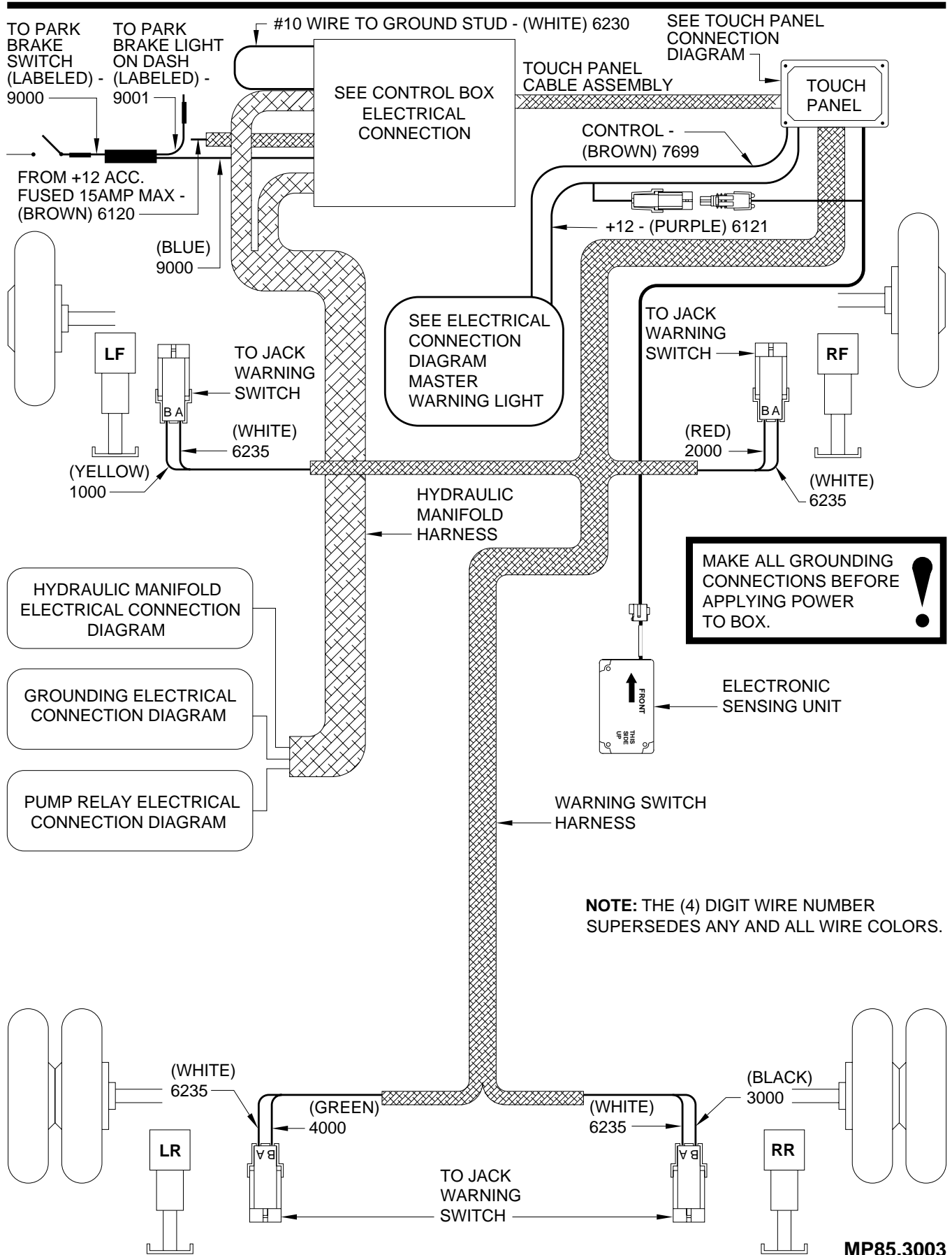

CONNECTION DIAGRAM

310/325 SERIES LEVELING SYSTEM TOUCH PANEL

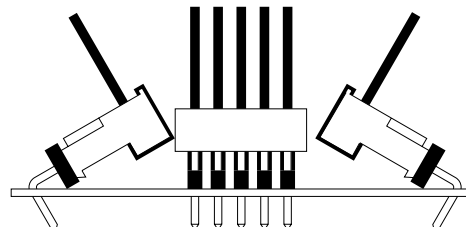
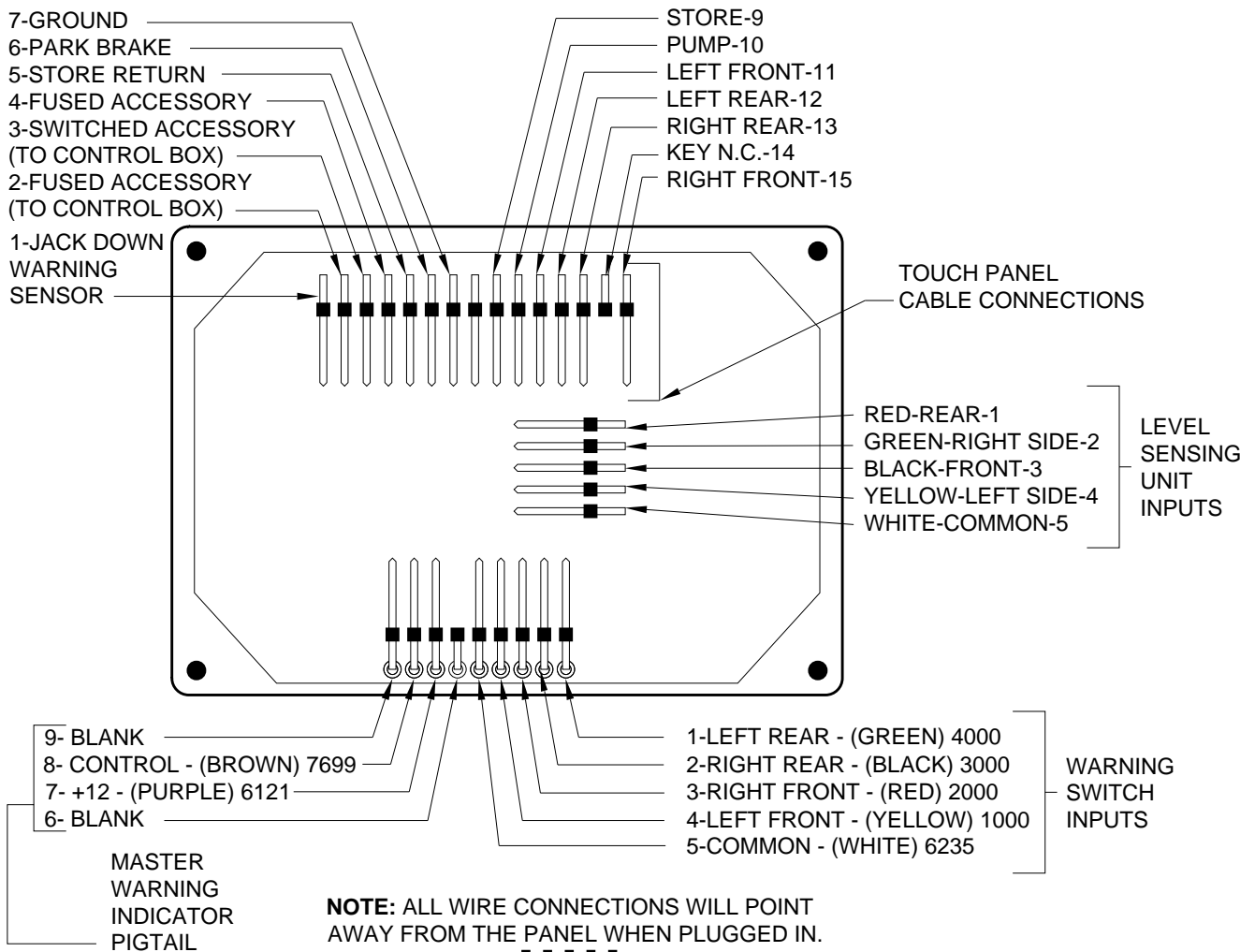
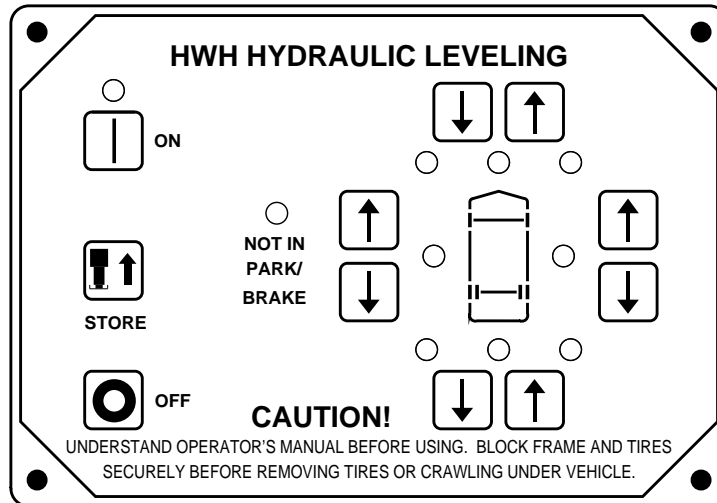

NOTE: THE (4) DIGIT WIRE NUMBER SUPERSEDES ANY AND ALL WIRE COLORS.

ELECTRICAL CONNECTION DIAGRAM CONTROL BOX 310/325 SERIES LEVELING SYSTEM

NOTE: THE (4) DIGIT WIRE NUMBER SUPERSEDES ANY AND ALL WIRE COLORS.

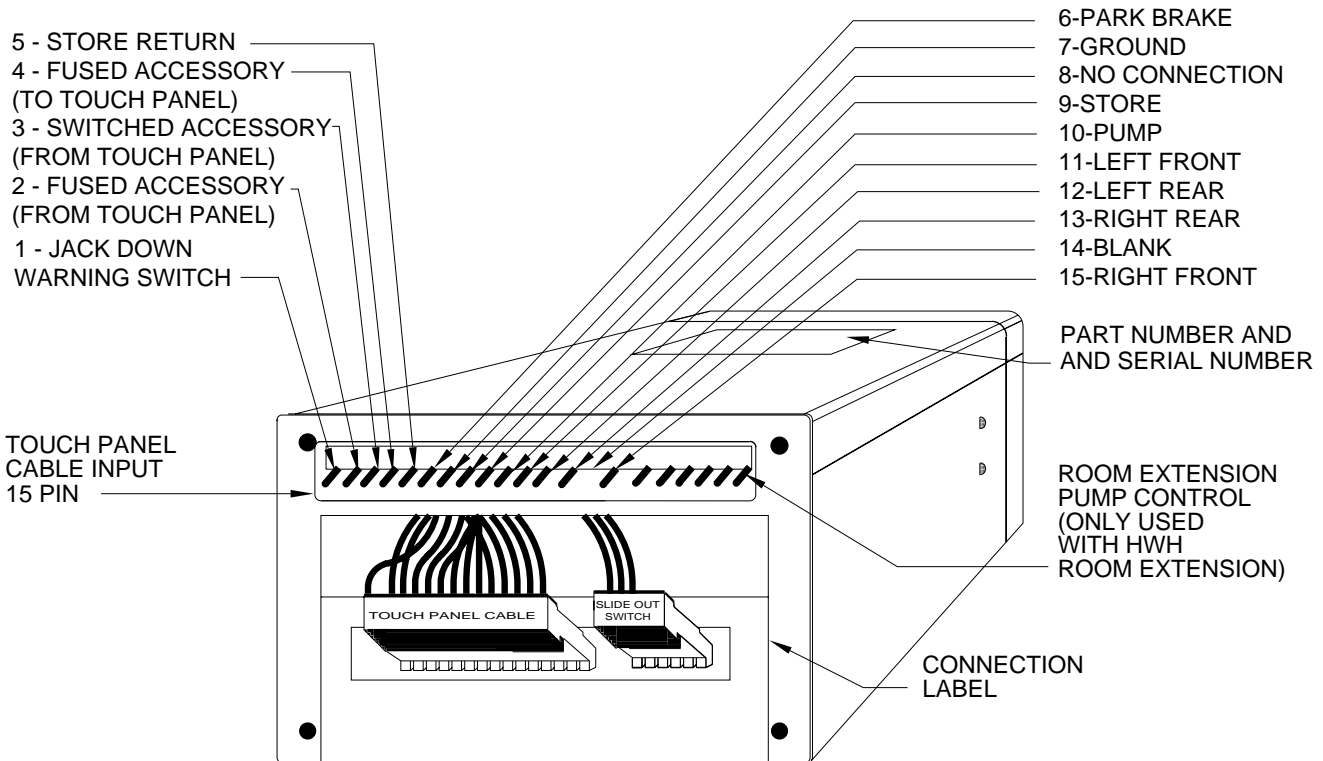
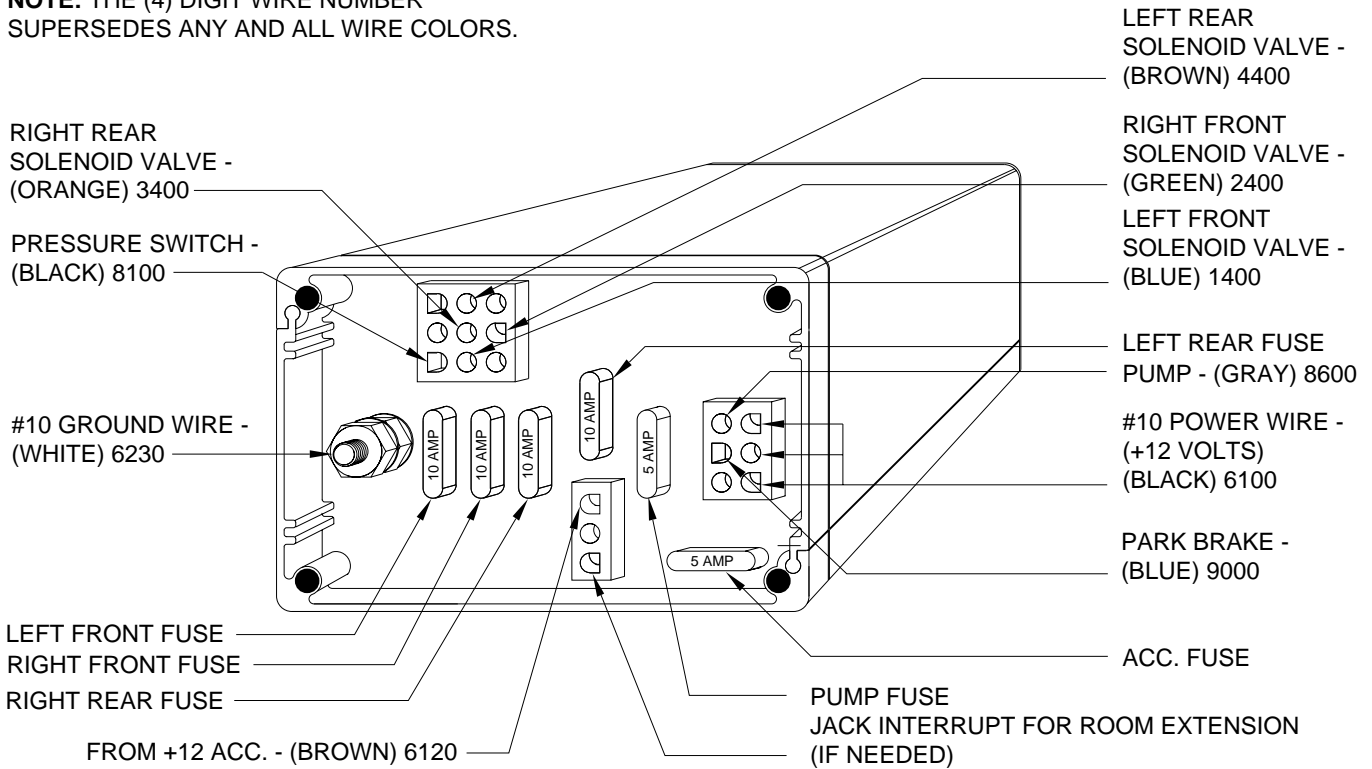

310 LEVELING SYSTEM HYDRAULIC MANIFOLD-PUMP RELAY ELECTRICAL CONNECTION DIAGRAM

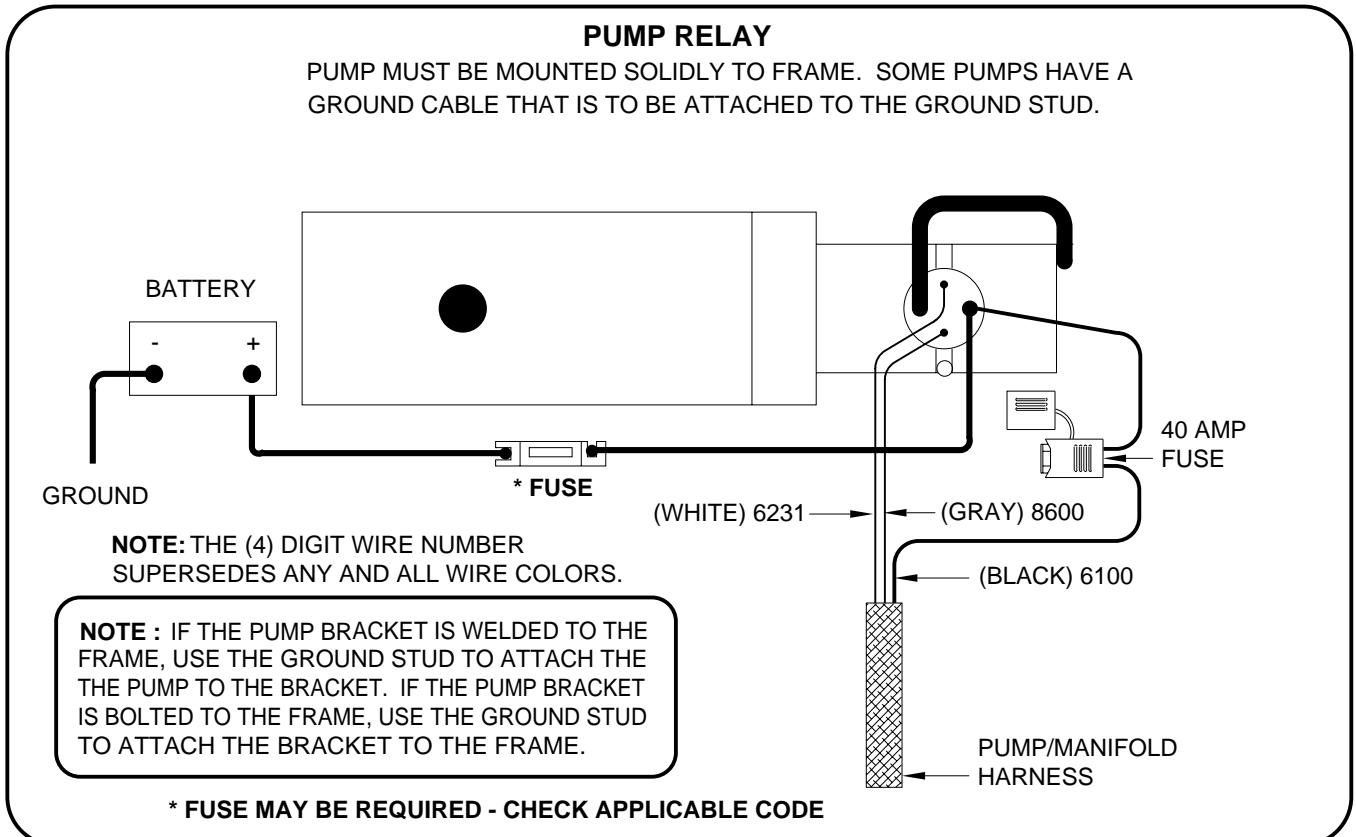
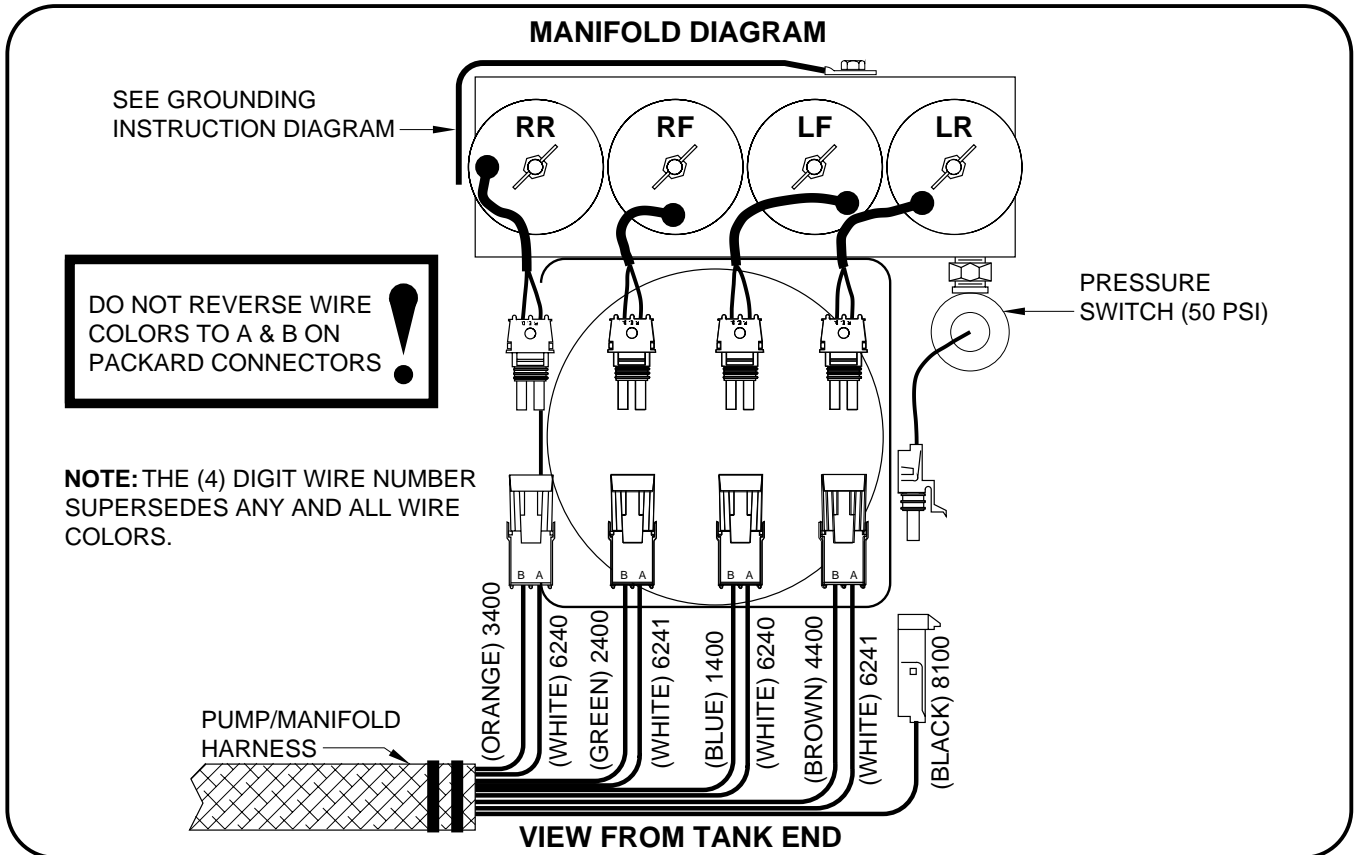

ELECTRICAL CONNECTION DIAGRAM

310/325 LEVELING SYSTEM POWER UNIT/HARNESS

GROUNDING INSTRUCTIONS

WELDED PUMP MOUNT

USE GROUNDING STUD AND 3/8" INTERNAL STAR LOCKWASHERS AS SHOWN.

IMPORTANT: STAR LOCKWASHER MUST BE USED BETWEEN GROUNDING SURFACE AND WIRE TERMINALS

MANIFOLD GROUND
SEE HYDRAULIC MANIFOLD/
PUMP RELAY ELECTRICAL
CONNECTION DIAGRAM

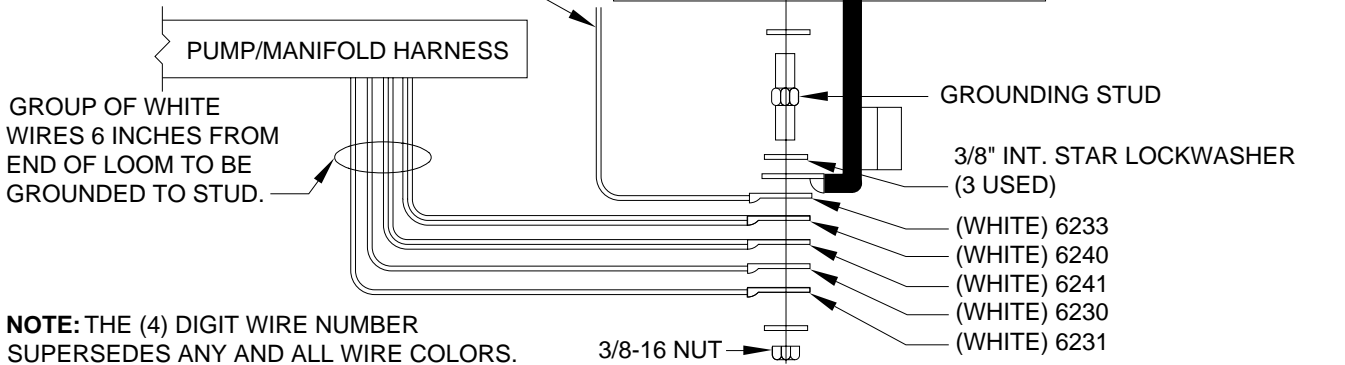

NOTE: THE (4) DIGIT WIRE NUMBER SUPERSEDES ANY AND ALL WIRE COLORS.

PUMP MOUNTED REMOTE FROM FRAME

USE GROUNDING STUD AND 3/8" INTERNAL STAR LOCKWASHERS AS SHOWN.

IMPORTANT: STAR LOCKWASHER MUST BE USED BETWEEN GROUNDING SURFACE AND WIRE TERMINALS.

NOTE: THE (4) DIGIT WIRE NUMBER SUPERSEDES ANY AND ALL WIRE COLORS.

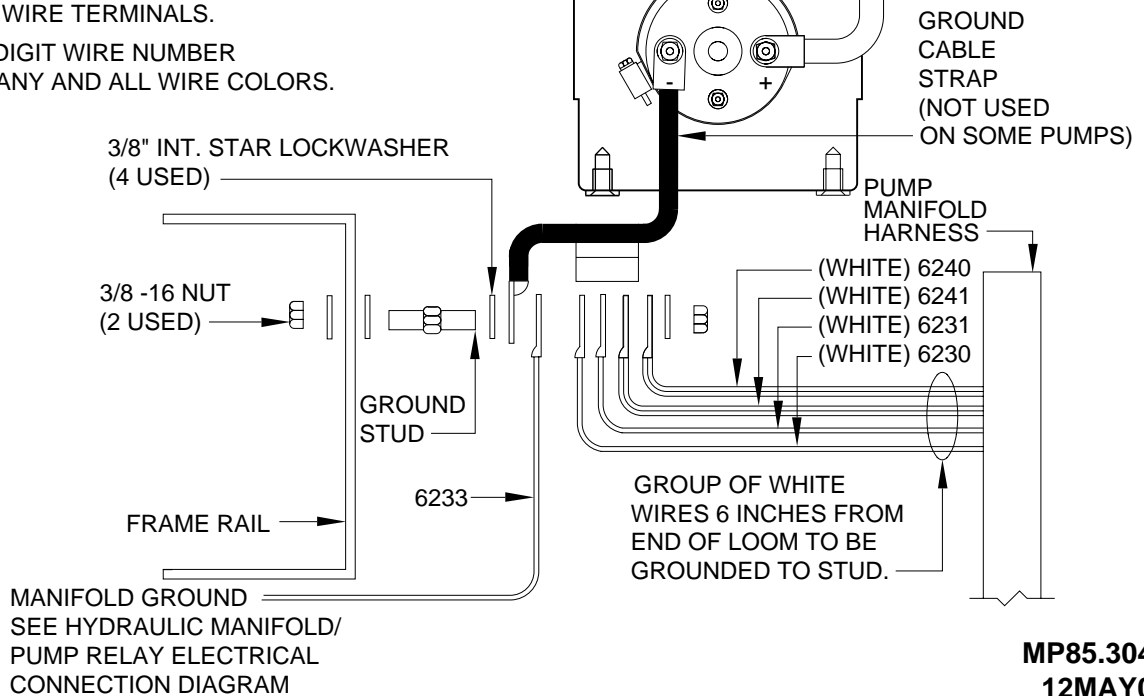

MASTER LIGHT/BUZZER CONNECTION DIAGRAM

MANUAL LEVELING SYSTEMS

310 SERIES

A MASTER WARNING INDICATOR SHOULD ALWAYS BE USED. WHEN THE LEVELING SYSTEM HAS STRAIGHT-ACTING JACKS A WARNING BUZZER MUST BE USED.

WHEN ONLY A RED MASTER WARNING LIGHT IS USED THE +12 POWER FOR THE LIGHT COMES THROUGH THE TOUCH PANEL. (SEE FIGURE 1 BELOW.) WHEN BOTH A RED LIGHT AND WARNING BUZZER ARE USED THE +12 POWER FOR BOTH INDICATORS IS SUPPLIED BY THE IGNITION SWITCH. THE POWER MUST COME FROM THE "ON" SIDE OF THE IGNITION SWITCH, NOT THE "ACC" SIDE. (SEE FIGURE 2 BELOW.)

NOTE: BY SUPPLYING IGNITION POWER TO THE WARNING BUZZER AND LIGHT, AND "ACC" POWER TO THE CONTROL BOX, THE SYSTEM MAY BE OPERATED IN ACCESSORY WITHOUT THE BUZZER SOUNDING. THE NEGATIVE SIGNAL FOR THE WARNING INDICATORS MUST ALWAYS COME FROM THE TOUCH PANEL.

CAUTION: THE PURPLE WIRE IN THE MASTER WARNING LIGHT PIGTAIL IS HOT WHENEVER THE IGNITION IS "ON" OR IN "ACC". THE PURPLE WIRE MUST BE REMOVED FROM THE PIGTAIL WHEN USING DIRECT IGNITION VOLTAGE FOR THE MASTER WARNING INDICATORS.

