



# OPERATOR'S MANUAL

## HWH COMPUTER-CONTROLLED LEVELING SYSTEM 500 SERIES

### SPACEMAKER ROOM EXTENSION SYSTEM

**FEATURING:**  
***TOUCH PANEL LEVELING CONTROL***  
***HYDRAULIC LEVELING***  
***AIR DUMP***  
***STRAIGHT-ACTING JACKS***  
***HYDRAULIC ROOM EXTENSION***

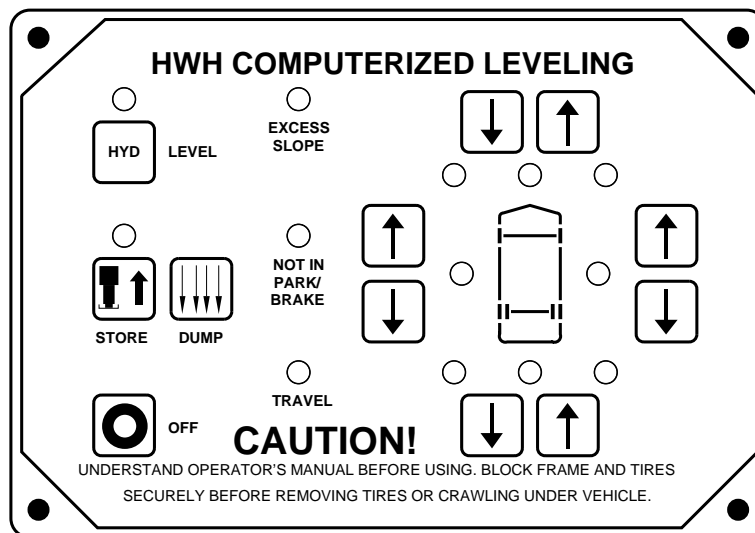

**HWH CORPORATION**  
**(ON I-80, EXIT 267 SOUTH)**  
**2096 MOSCOW ROAD**  
**MOSCOW, IOWA 52760**  
**(800) 321-3494 / (563) 724-3396**  
**INTERNET: <http://www.hwhcorp.com>**

---

# OPERATOR'S MANUAL

---

## CAUTION !

READ THE ENTIRE OPERATOR'S MANUAL BEFORE OPERATING.

BLOCK FRAME AND TIRES SECURELY BEFORE CRAWLING UNDER VEHICLE. DO NOT USE LEVELING JACKS OR AIR SUSPENSION TO SUPPORT VEHICLE WHILE UNDER VEHICLE OR CHANGING TIRES. VEHICLE MAY DROP AND/OR MOVE FORWARD OR BACKWARD WITHOUT WARNING CAUSING INJURY OR DEATH.

KEEP ALL PEOPLE CLEAR OF VEHICLE WHILE LEVELING SYSTEM AND ROOM EXTENSION ARE BEING OPERATED.

NEVER PLACE HANDS OR OTHER PARTS OF THE BODY NEAR HYDRAULIC LEAKS. OIL MAY PENETRATE SKIN CAUSING INJURY OR DEATH.

DO NOT OPERATE THE LEVELING SYSTEM OR USE THE DUMP OR RAISE BUTTONS IF THE VEHICLE IS MOVING IN EXCESS OF 5 MPH.

WEAR SAFETY GLASSES WHEN INSPECTING OR SERVICING THE SYSTEM TO PROTECT EYES FROM DIRT, METAL CHIPS, OIL LEAKS, ETC. FOLLOW ALL OTHER APPLICABLE SHOP SAFETY PRACTICES.

IMPORTANT: IF COACH IS EQUIPPED WITH A ROOM EXTENSION, READ ROOM EXTENSION SECTION BEFORE OPERATING LEVELING SYSTEM.

## HOW TO OBTAIN WARRANTY SERVICE

### THIS IS NOT TO BE INTERPRETED AS A STATEMENT OF WARRANTY

HWH CORPORATION strives to maintain the highest level of customer satisfaction. Therefore, if you discover a defect or problem, please do the following:

**FIRST:** Notify the dealership where you purchased the vehicle or had the leveling system installed. Dealership management people are in the best position to resolve the problem quickly. If the dealer has difficulty solving the problem, he should immediately contact the Customer Service Department, at HWH CORPORATION.

**SECOND:** If your dealer cannot or will not solve the problem, notify the Customer Service Department:  
HWH CORPORATION 2096 Moscow Rd. Moscow IA. 52760  
(563) 724-3396 OR (800) 321-3494. Give your name and address, coach manufacturer and model year, date the coach was purchased, or the date of system installation,

description of the problem, and where you can be reached during business hours (8:00 a.m. till 5:00 p.m. c.s.t.). HWH CORPORATION personnel will contact you to determine whether or not your claim is valid. If it is, HWH CORPORATION will authorize repair or replacement of the defective part, either by appointment at the factory or by the authorization of an independent service facility, to be determined by HWH CORPORATION. All warranty repairs must be performed by an independent service facility authorized by HWH CORPORATION, or at the HWH CORPORATION factory, unless prior written approval has been obtained from proper HWH CORPORATION personnel.

# CONTROL IDENTIFICATION

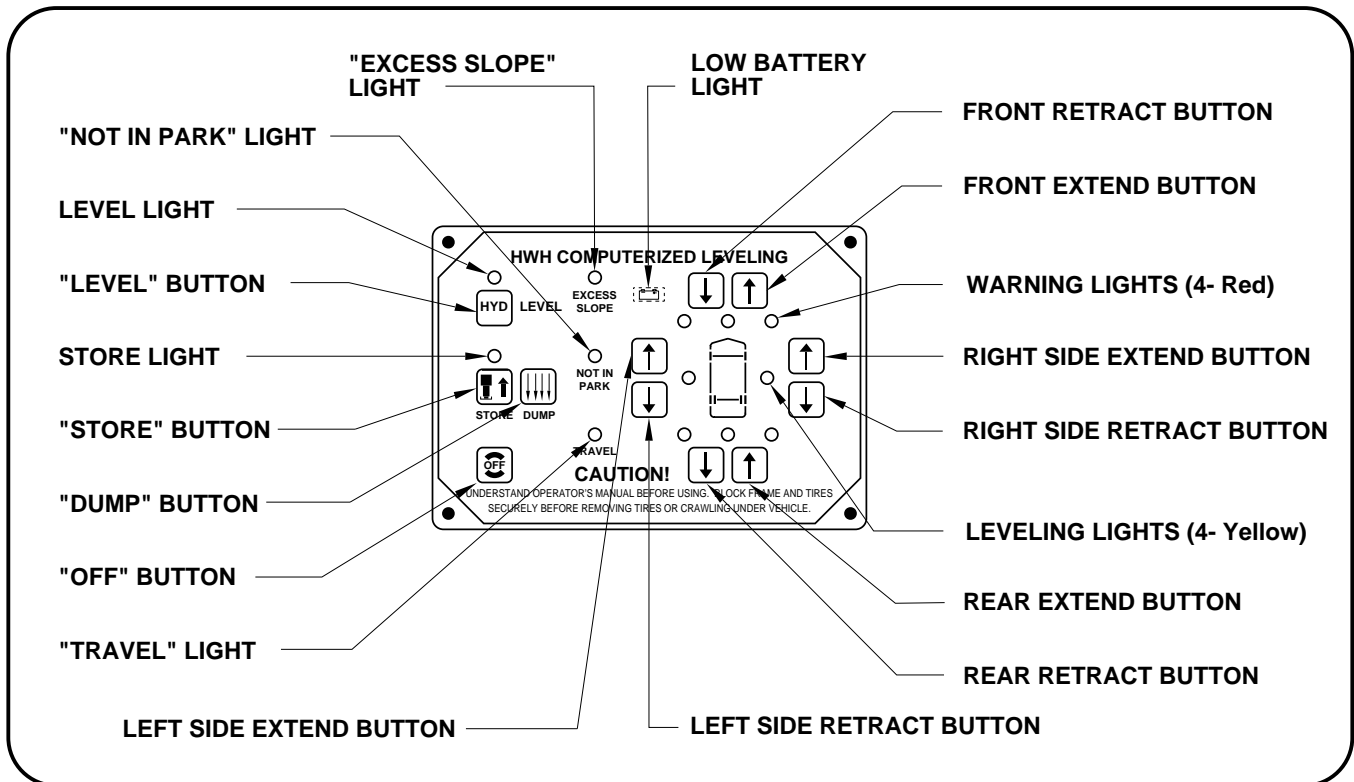

## CONTROL FUNCTIONS

### CONTROL BUTTONS

**"OFF" BUTTON:** Push the "OFF" button to stop hydraulic operation.

**"LEVEL" BUTTON:** This is the on button and automatic operation button. The on indicator light is above the "HYD" button.

**"STORE" BUTTON:** The store indicator light is above the "STORE" button. This button is used to automatically retract the jacks.

**"DUMP" BUTTON:** This is a manual button for dumping air from the vehicle suspension. See MANUAL AIR DUMP Section.

**EXTEND BUTTONS (UP ARROWS):** These buttons will extend their respective jack pairs to lift the vehicle.

**RETRACT BUTTONS (DOWN ARROWS):** These buttons will retract their respective jack pairs to lower the vehicle.

### INDICATOR LIGHTS

**LEVELING LIGHTS :** The four yellow indicating lights are level sensing indicators. When a yellow light is on, it indicates that its side, end, or corner of the vehicle is low. No more than two lights should be on at the same time.

**WARNING LIGHTS:** The four red lights surrounding the yellow level indicators are jacks down WARNING lights. They are functional only when the ignition is in the "ON" or "ACC" position, the system is on, and the jacks are extended 2 or more inches.

**"EXCESS SLOPE" LIGHT:** This indicator will light when the leveling system cannot level the vehicle.

**"NOT IN PARK/BRAKE" LIGHT:** This indicator will light when the panel is on and the hand/auto brake is not set.

**"TRAVEL" LIGHT:** This indicator light will be on when the ignition is on, when the jacks are retracted and there are no red WARNING lights on.

**LOW BATTERY LIGHT:** This indicator will be on when the controller senses low voltage.

**MASTER "JACKS DOWN" WARNING LIGHT:** This is a light mounted in the dash separate from the touch panel. It will be on when any one or more jacks are extended and the ignition is "ON".

**BUZZER:** This is a jacks down warning. It will sound if the master "JACKS DOWN" warning light is on.

## CONTROL IDENTIFICATION

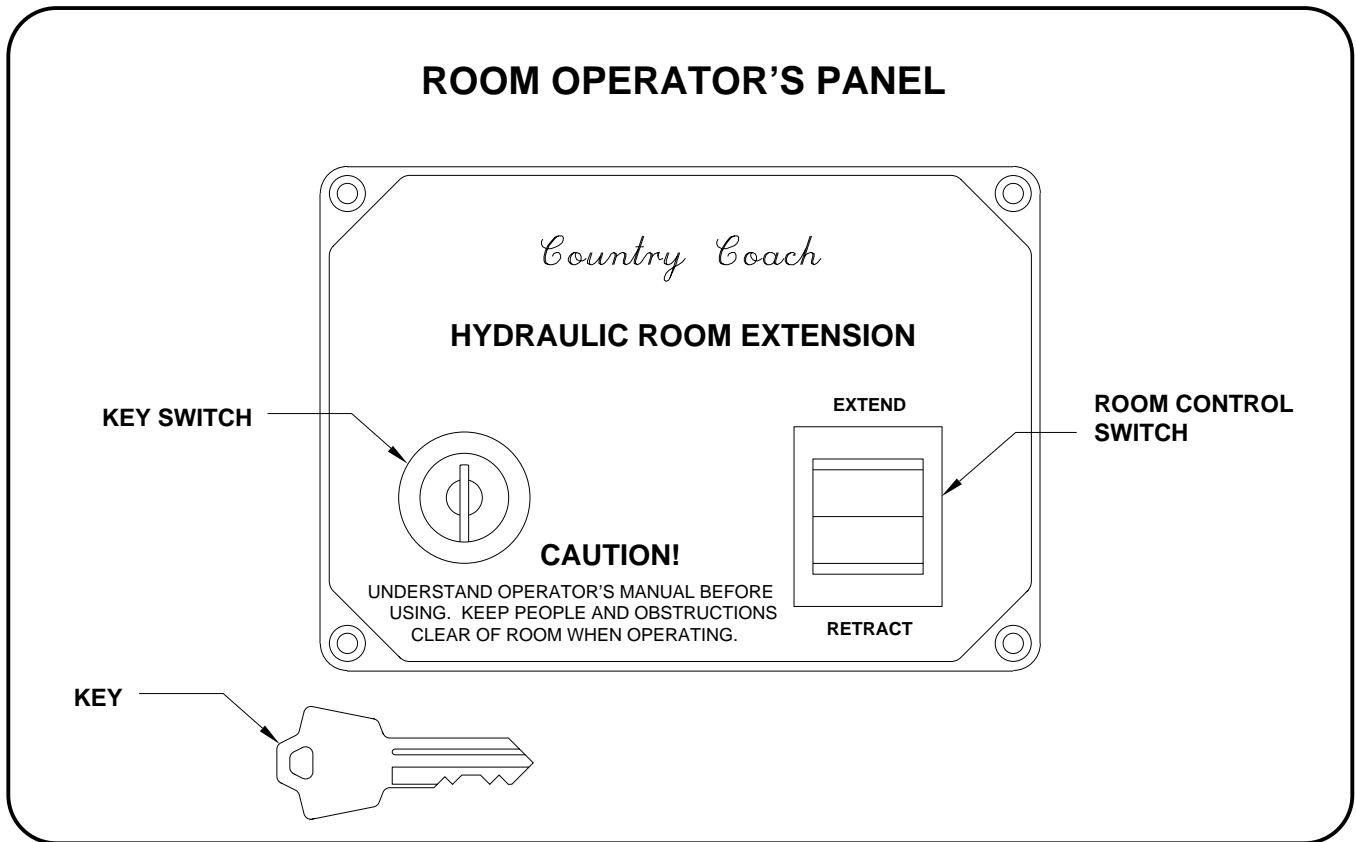

## CONTROL FUNCTIONS

**KEY SWITCH:** The KEY SWITCH controls power to the ROOM CONTROL SWITCH. When the KEY SWITCH is in the "ON" position the room can be operated, and the key cannot be removed. When the KEY SWITCH is in the "OFF" position the room cannot be operated, and the key can be removed.

**ROOM CONTROL SWITCH:** The ROOM CONTROL SWITCH is a two position momentary switch. Pressing the switch in the EXTEND position will extend the room. Pressing the switch in the RETRACT position will retract the room. Releasing the ROOM CONTROL SWITCH will halt the operation of the room.

---

# OPERATING PROCEDURES

---

## GENERAL INSTRUCTIONS

If parking on soft ground or asphalt paving, wood blocks or pads must be placed under the jacks.

Press the "OFF" button or turn the ignition switch "OFF" at any time to stop the operation of the system.

Any time a hydraulic leveling process is interrupted, retract the jacks according to the JACK RETRACTION section and then restart the leveling process.

If the "LOW BATTERY" indicator is on, the system should be checked. Battery voltage should be checked, also all connections should be checked.

If the hand/auto brake is not set when the "HYD" button is pressed, the "NOT IN PARK/BRAKE" light will come on and the system will not operate.

**CAUTION:** DO NOT MOVE THE VEHICLE IF A WARNING LIGHT OR BUZZER IS ON.

## MANUAL AIR DUMP

The "DUMP" button is used to manually dump air from the vehicle's suspension system. This will lower the vehicle. It can be used while the vehicle is moving or stationary.

**CAUTION:** IF DUMPING AIR FROM THE SUSPENSION, THE COACH SHOULD NOT BE MOVING AT A SPEED GREATER THAN 5 MPH.

The "DUMP" button will work if the ignition is on and the leveling system is off, or if the leveling system is on.

The "DUMP" button is a momentary button and will dump air only while the button is being pushed.

**IMPORTANT:** If the air is not completely exhausted from the suspension or the vehicles engine is running, the vehicle will return to the proper travel height when the "DUMP" button is released.

## PREPARATION FOR TRAVEL

Before traveling, the red jack "WARNING" lights must be off and the "TRAVEL" light must be on. If lights are not correct for travel, retract jacks as described in the JACK RETRACTION section.

The room extension should be fully retracted before moving the vehicle.

If the jacks are retracted but a red "WARNING" light is lit or the green "TRAVEL" light is not lit, the system needs to be serviced.

The suspension air bags should be inflated and the vehicle should be at the proper ride height before traveling.

**CAUTION:** DO NOT MOVE THE VEHICLE WHILE THE LEVELING JACKS ARE STILL IN CONTACT WITH THE GROUND

OR IN THE EXTENDED POSITION. THIS VEHICLE IS EQUIPPED WITH STRAIGHT ACTING JACKS. MOVING THE VEHICLE WITH THE LEVELING JACKS EXTENDED CAN CAUSE SEVERE DAMAGE TO THE JACKS AND OR THE VEHICLE AND CREATE A DRIVING HAZARD. DO NOT RELY SOLELY UPON WARNING LIGHTS. IT IS THE OPERATOR'S RESPONSIBILITY TO CHECK THAT ALL JACKS ARE FULLY RETRACTED INTO THE STORE/TRAVEL POSITION.

If the jacks cannot be retracted according to the JACK RETRACTION section, retract the jacks according to the MANUAL JACK RETRACTION section. The system should then should be checked.

## ROOM EXTENSION PROCEDURES

**IMPORTANT:** This vehicle is equipped with a room extension. Read this section carefully.

Do NOT operate any room extension until the leveling and stabilizing procedure is complete. Do NOT retract the leveling system until all room extensions are retracted. Do NOT operate the leveling system when any room extensions are extended.

Refer to the vehicle owners manual for proper operation of room extensions.

**IMPORTANT:** Do not use a room extension support when the vehicle is supported by the leveling system.

# OPERATING PROCEDURES

## AUTOMATIC HYDRAULIC LEVELING

1. Place transmission in the recommended position for parking vehicle and set parking brake. Turn the coach engine off. Turn the ignition to the "ACCESSORY" position.

**NOTE:** Running the vehicle engine during leveling can cause erratic operation and inhibit proper leveling of the vehicle.

2. Press the "HYD" button to enter the hydraulic operation mode. The "HYD" indicator light will glow steady.

3. At this time the operator may want to check the jacks and place pads under the jacks if the ground will not support the vehicle.

4. Press the "HYD" button a second time. The "HYD" indicator light will start to flash. The system will begin to dump air from the vehicle suspension. After approximately 45 seconds, the

system will automatically extend the jacks to level the vehicle and then extend any remaining jacks until they touch the ground. After the system has finished leveling and stabilizing, and has completed the air dump cycle it will automatically shut off.

**EXCESS SLOPE SITUATION:** In the event the jacks are unable to level the coach the "EXCESS SLOPE" indicator light will come on. The pump will shut off. One or two yellow leveling indicator lights will remain on. The "HYD" indicator light will continue to blink for 2 minutes, then the system will shut off. The system will NOT stabilize the vehicle if the "EXCESS SLOPE" light comes on. Store the jacks according to the JACK RETRACTION section. Move the vehicle to a more level position or level the vehicle as close as possible according to the MANUAL HYDRAULIC OPERATION section.

5. Turn the ignition switch to the "OFF" position.

## ROOM EXTEND PROCEDURE

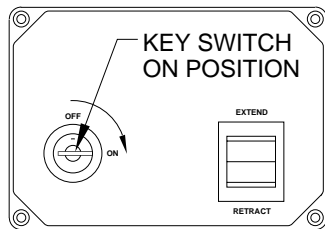

FIGURE 1

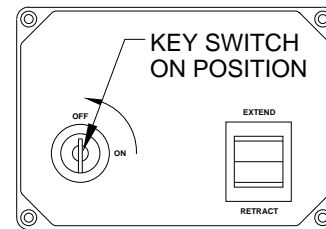

FIGURE 2

**CAUTION:** OPERATING THE ROOM WITH ANY ROOM -LOCKING DEVICES LOCKED OR THE MANUAL-RETRACT WINCH ATTACHED CAN CAUSE PERSONAL INJURY AND VEHICLE DAMAGE. IT IS THE OPERATOR'S RESPONSIBILITY TO ENSURE THAT ALL ROOM-LOCKING DEVICES AND THE MANUAL-RETRACT WINCH ARE DIS-ENGAGED BEFORE OPERATING THE ROOM.

**IMPORTANT:** The park brake must be set and the vehicle must be leveled using the hydraulic leveling system before the room can be extended or retracted. If the leveling system stopped with the excess slope light on, see "EXCESS SLOPE SITUATION" under "AUTOMATIC HYDRAULIC LEVELING". DO NOT EXTEND the room.

1. Follow the LEVELING AND STABILIZING PROCEDURE.

2. Unlock all room-locking devices.

**NOTE:** If the MANUAL RETRACT WINCH is attached to the room, remove it before extending the room.

**CAUTION:** KEEP PEOPLE AND OBSTRUCTIONS CLEAR OF ROOM WHEN OPERATING.

**NOTE:** Make sure there is adequate clearance to fully extend the room.

3. Turn the ignition switch to ACCESSORY.

4. Press the "HYD" button if the HYDRAULIC OPERATION LIGHT is not illuminated. Refer to the CONTROL IDENTIFICATION page.

**NOTE:** To operate the room, the HYDRAULIC OPERATION light and a WARNING light must be illuminated. The room will not extend if the system is in automatic leveling or retract.

5. Turn the KEY SWITCH on the room extension operator's panel to the "ON" position. (Figure 1)

6. To EXTEND the room, press and hold the ROOM CONTROL switch in the EXTEND position. When the room is fully extended, release the ROOM CONTROL switch.

**IMPORTANT:** Do NOT hold the ROOM CONTROL switch in the EXTEND position for more than ten seconds after the room is fully extended. If either side of the room stops moving, release the ROOM CONTROL SWITCH immediately.

**NOTE:** Releasing the ROOM CONTROL switch will halt the operation of the room.

7. Press the "OFF" button.

8. Turn the KEY SWITCH to the "OFF" position and remove the key. (See Figure 2)

9. Turn off the ignition switch.

**IMPORTANT:** Do NOT use the room extension support when the vehicle is supported by the leveling system.

---

# OPERATING PROCEDURES

---

## ROOM RETRACT PROCEDURE

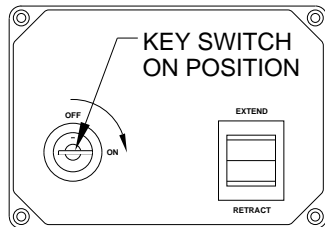

FIGURE 1

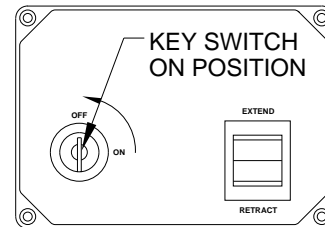

FIGURE 2

**CAUTION:** KEEP PEOPLE AND OBSTRUCTIONS CLEAR OF THE ROOM WHEN OPERATING.

1. Turn the ignition switch to ACCESSARY.
2. Press the "HYD" BUTTON.
3. Turn the KEY SWITCH on the room extension operator's panel to the "ON" position. (See Figure 1)

NOTE: To retract the room the HYDRAULIC OPERATION LIGHT must be illuminated. A WARNING LIGHT does NOT need to be on.

4. To retract the room press and hold the ROOM CONTROL SWITCH in the RETRACT position. When the room is fully retracted, release the ROOM CONTROL SWITCH.

NOTE: The room can be retracted ten seconds after the Leveling System is put in the STORE mode. This will interrupt the STORE mode until the ROOM CONTROL SWITCH is released. The Leveling System will continue to STORE starting from the beginning of the program.

**IMPORTANT:** Do NOT hold the ROOM CONTROL SWITCH in the RETRACT position for more than ten seconds after the room is fully retracted. If either side of the room stops moving release the CONTROL SWITCH immediately.

NOTE: Releasing the ROOM CONTROL SWITCH will halt the operation of the room.

5. Press the "OFF" Button or let the system continue to STORE.
6. Turn the KEY SWITCH to the off position and remove the key. (See Figure 2)
7. Turn the ignition switch off.
8. Engage all room-locking devices.
9. If the room will not retract see the MANUAL ROOM RETRACT PROCEDURE.

**IMPORTANT:** Room-locking devices should be locked while traveling.

# OPERATING PROCEDURES

## JACK RETRACTION

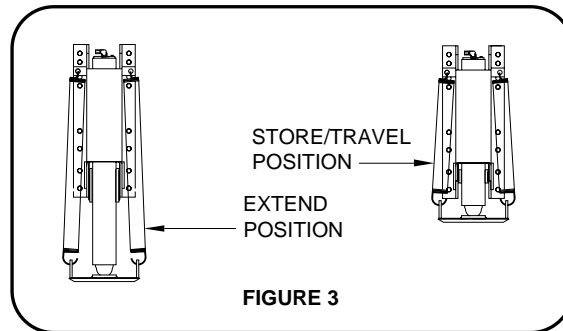

**CAUTION:** THE OPERATOR MUST BE SURE THAT THERE ARE NO OBJECTS UNDER THE VEHICLE AND THAT ALL PEOPLE ARE CLEAR OF THE VEHICLE.

1. Turn the ignition switch to the "ACC" position. Press the "HYD" button one time. The "HYD" indicator light will glow steady.
2. Press the "STORE" button. The store indicator light will flash. The front jacks will retract for approximately 5 seconds before the rear jacks start to retract. As each jack retracts, its red WARNING light will go out. The system will automatically shut down six minutes after the four individual red "WARNING" lights are out. If any one red "WARNING" light does not go out, the system will continue to store for thirty minutes, then shut down regardless of the "WARNING" lights condition.

**IMPORTANT:** Do NOT interrupt power to the leveling system while the "STORE" indicator light is blinking. Do NOT push the "OFF" button or turn the ignition key. The system must be allowed to completely finish the store mode.

**CAUTION:** DO NOT MOVE THE VEHICLE WHILE THE LEVELING JACKS ARE STILL IN CONTACT WITH THE GROUND OR IN THE EXTEND POSITION. THIS VEHICLE IS EQUIPPED WITH STRAIGHT ACTING JACKS. MOVING THE VEHICLE WITH THE LEVELING JACKS EXTENDED CAN CAUSE SEVERE DAMAGE TO THE JACKS AND OR THE VEHICLE AND CREATE A DRIVING HAZARD. DO NOT RELY SOLELY UPON WARNING LIGHTS. IT IS THE OPERATOR'S RESPONSIBILITY TO CHECK THAT ALL JACKS ARE FULLY RETRACTED INTO THE STORE/TRAVEL POSITION.

3. Start the vehicle engine and build up air pressure in the suspension system. The vehicle can be moved as soon as the red WARNING lights are out, the green "TRAVEL" light is on, and the suspension air bags are inflated and the vehicle has returned to the proper ride height, providing the jacks are in the STORE/TRAVEL position. (See FIGURE 3)

**IMPORTANT:** Do NOT move the vehicle with the room extension extended.

4. If jacks cannot be retracted by the above procedure see MANUAL JACK RETRACTION section.

## MANUAL JACK RETRACTION

NOTE: Use the valve release "T" handles for retracting only if the "STORE" button on the control panel will not retract the jacks for travel.

**CAUTION:** KEEP AWAY FROM THE WHEELS, DO NOT CRAWL UNDER THE VEHICLE, KEEP A SAFE DISTANCE IN FRONT AND REAR OF VEHICLE. THE VEHICLE MAY DROP AND/OR MOVE FORWARD OR BACKWARD WITHOUT WARNING AS THE VALVE RELEASE IS OPERATED.

1. Locate the 4 valve release "T" handles on the solenoid valves. The solenoid valves are located on the valve assembly. (See the HYDRAULIC CONNECTION DIAGRAM)
2. Allow clearance for vehicle to lower.
3. Retract the front jacks by opening the two center valves. Slowly turn the "T" handles counter clockwise. The handles may turn

easily at first but as an internal spring is compressed, turning may become more difficult. The valves need only to be opened enough to retract the jack.

4. Retract the rear jacks by opening the two outer valves as described in step 3.
5. Check that all four jacks are now retracted.
6. Close the valves by turning the release handles clockwise.

Once the internal spring tension has been released, the handles will turn free for several turns. Once the "T" handles are snug, DO NOT tighten the handles past this point as internal damage may occur to the solenoid.

7. The system should now be repaired before using again.



**MANUAL ROOM RETRACT PROCEDURE**  
**USE ONLY WHEN ROOM CANNOT BE RETRACTED WITH THE ROOM CONTROL SWITCH OR THE MANUAL RETRACT WINCH.**  
**THIS SHOULD BE DONE BY A CERTIFIED TECHNICIAN ONLY.**  
**CONTACT HWH CORPORATION FOR ASSISTANCE AT (1-800-321-3494).**

When extending or retracting the room, if one side of the room does not move, release the room control switch immediately. The rack sensing valve plunger (1, FIGURE 1) may be stuck, bent or not touching the strike plate (2, FIGURE 1).

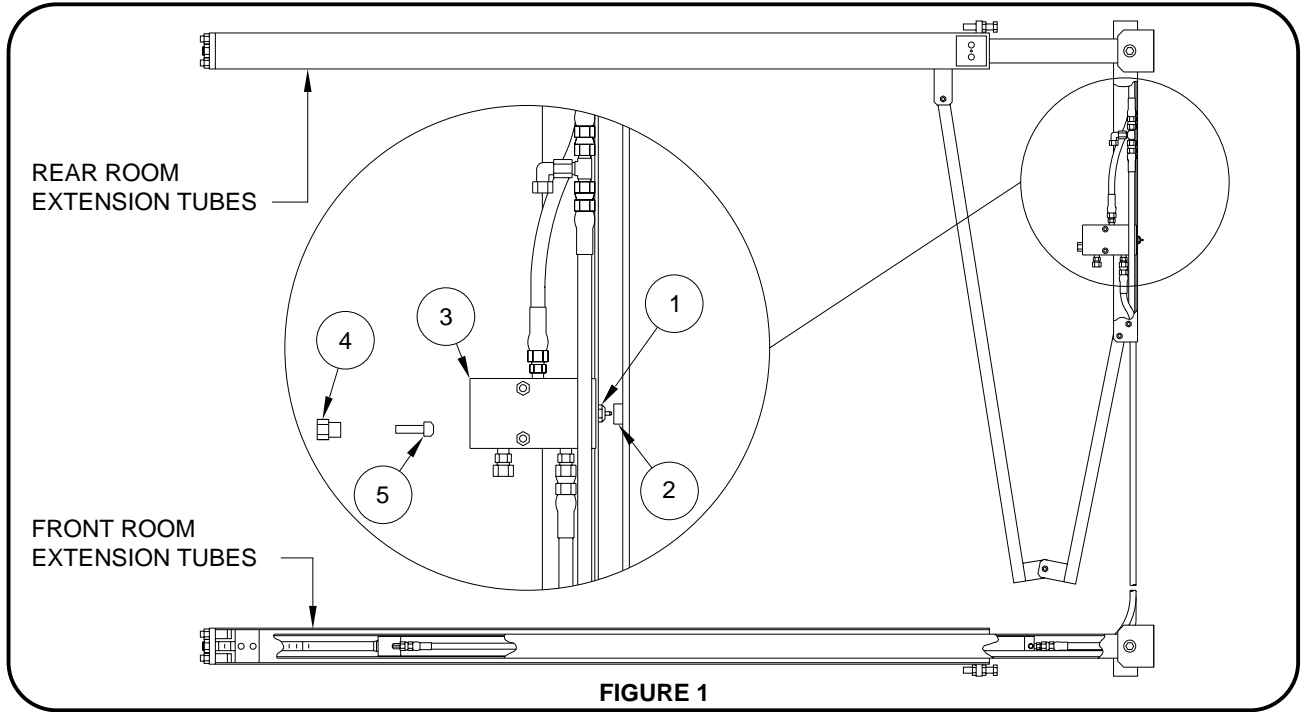
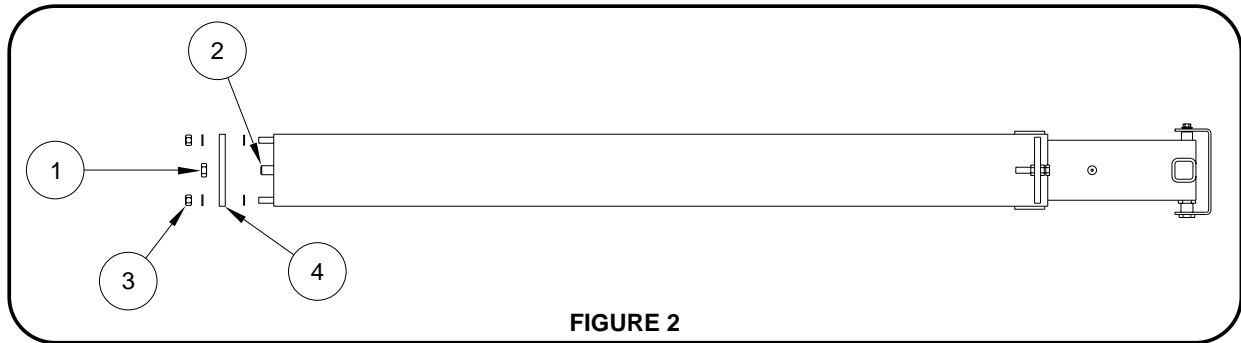

**FIGURE 1**

**ROOM IN EXTENDED POSITION**

Refer to page MP35.9490 in the Operator's Manual or the repair manual, and try to manually retract the room, if it is extended. If the manual winch provided will not retract the room, **DO NOT USE ALTERNATE DEVICES SUCH AS A POWER WINCH.** If possible repair the rack sensing valve (3, FIGURE 1) before retracting the room. If repair is not possible, release the pressure on the manual retract winch. Remove the check valve cap (4, FIGURE 1) from the back of the rack sensing valve. Remove the check valve poppet (5, FIGURE 1). Replace the check valve cap. Retract the room using the manual retract winch according to MP35.9490. **DO NOT** use the room extension until the rack sensing valve has been replaced. Leave the manual winch in place and have the room extension repaired.

**WARNING:** ROOM EXTENSION SOLENOID VALVE "T" HANDLES MUST BE IN THE OPEN POSITION WHEN THE MANUAL RETRACT WINCH IS CONNECTED. **DO NOT** USE THE ROOM EXTENSION OR LEVELING SYSTEM WHEN THE ROOM EXTENSION HYDRAULIC HOSES ARE DISCONNECTED.



**FIGURE 2**

**ROOM IN RETRACTED POSITION**

If one side of the room will not move while extending, repair the rack sensing valve before continuing. Remove the cylinder adjusting locknut (1, FIGURE 2). Turn the cylinder adjusting rod (2, FIGURE 2) clockwise as far as possible. If this is not enough room to work on the valve, remove the cylinder mounting plate nuts (3, FIGURE 2) and the cylinder mounting plate (4, FIGURE 2). The room can then be pulled out far enough to work on the rack sensing valve. Contact HWH Corporation, 1-800-321-3494, for the correct rack sensing valve and cylinder replacement and adjustment instruction sheets.

# MANUAL ROOM RETRACT PROCEDURE (WITH SOLENOID VALVES WITH VALVE RELEASE "T" HANDLES)

(USE ONLY WHEN THE ROOM WILL NOT RETRACT WITH THE ROOM CONTROL SWITCH)

## OVERVIEW

The room can be retracted manually if a hydraulic or electric failure prevents the room from being retracted using the CONTROL SWITCH. For normal retract sequence see the ROOM SLIDE RETRACT PROCEDURES. Refer to the vehicle manufacturer for storage location of the retract device and information for connecting the device to the room.

**IMPORTANT:** If the vehicle is not equipped with a winch, DO NOT use other pulling devices to retract the room. Follow steps 2 and 3 and try pushing the room in. Contact the vehicle manufacturer or HWH Customer Service at 1-800-321-3494 or 563-724-3396 for assistance.

**WARNING:** THE MANUAL RETRACT WINCH IS EQUIPPED FOR MANUALLY RETRACTING THE ROOM ONLY. IT IS NOT TO BE USED FOR LIFTING OR ANY OTHER APPLICATION. HIGH FORCES ARE CREATED WHEN USING A WINCH, CREATING POTENTIAL SAFETY HAZARDS. FAILURE TO FOLLOW ALL CAUTIONS AND INSTRUCTIONS MAY CAUSE FAILURE OF THE MANUAL RETRACT WINCH OR CONNECTIONS RESULTING IN DAMAGE OR PERSONAL INJURY. MAINTAIN FIRM GRIP ON THE WINCH HANDLE AT ALL TIMES. NEVER RELEASE THE HANDLE WHEN RATCHET LEVER IS IN THE OFF POSITION AND THE WINCH IS LOADED. THE WINCH HANDLE COULD SPIN VIOLENTLY AND CAUSE PERSONAL INJURY. CHECK THE WINCH AND STRAPS FOR DAMAGE OR WEAR, AND CHECK FOR PROPER RATCHET OPERATION ON EACH USE OF THE WINCH. DO NOT USE IF DAMAGED OR WORN.

1. Retract jacks following the LEVELING SYSTEM RETRACT PROCEDURE.

**NOTE :** When manually retracting the room, make sure the jacks are retracted before retracting the room.

2. Locate the HYDRAULIC PUMP/MANIFOLD unit.

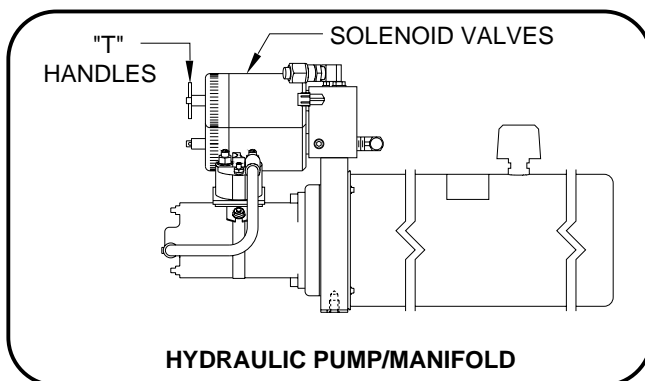

3. Open the SOLENOID VALVES by turning the "T" HANDLES counterclockwise.

**NOTE :** The "T" HANDLE may turn easily at first but will become more difficult to turn as an internal spring is compressed. Be sure to open both valves completely (about six turns of the "T" HANDLE).

**NOTE :** The room may move slightly as the SOLENOID VALVES are opened and internal pressure is released.

4. Locate the MANUAL RETRACT WINCH and connect it to the room according to the vehicle manufacturer's instructions. To extend the WINCH STRAP firmly grasp WINCH HANDLE, place RATCHET LEVER in its OFF position, and slowly rotate the WINCH HANDLE counterclockwise, keeping a firm grip on the handle. When enough WINCH STRAP is extended, place the RATCHET LEVER in its ON position and slowly rotate the WINCH HANDLE clockwise until the RATCHET LEVER locks.

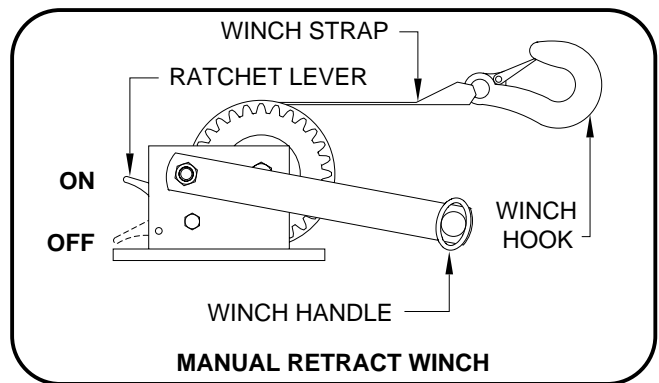

5. Slowly winch the room in by turning the WINCH HANDLE clockwise. The RATCHET LEVER should produce a loud, sharp, clicking noise.

**NOTE :** Winching the room in quickly will raise pressure in the hydraulic fluid and make winching more difficult.

**WARNING:** OPERATE THE MANUAL RETRACT WINCH BY HAND POWER ONLY. IF THE WINCH CANNOT BE CRANKED EASILY WITH ONE HAND IT IS PROBABLY OVER-LOADED. IF WINCHING BECOMES TOO DIFFICULT STOP AND CHECK FOR OBSTRUCTIONS OR RESTRICTIONS ON THE ROOM AND ROOM EXTENSION MECHANISM.

6. When the room is fully retracted, engage the room locking devices. Leave the retract winch in place.

**WARNING:** THE ROOM EXTENSION SOLENOID VALVE "T" HANDLES MUST BE IN THE OPEN POSITION WHEN THE MANUAL RETRACT WINCH IS ENGAGED.

7. The system should be repaired before using again.

---

# MAINTENANCE

---

## OIL LEVEL

It is important that the room and four leveling jacks are fully retracted before checking the hydraulic oil level. To check the oil supply remove the breather cap from the top of the hydraulic oil reservoir. The oil level should be approximately one inch below the top of the reservoir when adequately filled.

**FLUID:** HWH Specialty Hydraulic Oil is recommended. In an emergency Dexron automatic transmission fluid can be used.  
**NOTE:** Dexron automatic transmission fluid contains red dye and can cause staining should a leak occur. **DO NOT USE** brake fluid or hydraulic jack fluid. Use of these can damage seals.

## ELECTRICAL SYSTEM

The batteries should be in good condition and fully charged. Weak batteries can cause erratic operation. Battery cable terminals and battery posts and connections should be kept clean.

All electrical connections, especially ground connections, should be clean, tight, free from corrosion and protected from weathering.

## UNUSUAL CONDITIONS

If driving conditions are unusually muddy, the jacks may become caked or clogged with mud. This condition may hamper the proper operation of the leveling system. This problem may be prevented or remedied by cleaning off each leveling jack if they become excessively muddy.

Do not move the vehicle while the leveling jacks are still in contact with the ground. Retract the jacks according to the "JACK RETRACTION" section and then visually check to see if the leveling jacks have returned to the STORE/TRAVEL position.

In wet or icy weather leveling jacks may become encrusted with ice. This may cause the leveling system to function improperly. To eliminate this problem, periodically check the leveling jacks and break loose any ice which may be causing improper operation.

**NOTE:** All major components of the system can be replaced with rebuilt parts or can be sent to HWH CORPORATION to be rebuilt, when the system is out of warranty.

## OPERATIONAL CHECK

**Review the operator manual and run the system in the automatic and manual mode. Note any abnormal operation.**

Check the air system by using the manual "DUMP" button. If the system will not dump air, or return to the proper travel height, contact your dealer or HWH CORPORATION.

Check that all lights work according to the INDICATOR LIGHT section. Correct function of the four red WARNING lights is essential to the correct operation of the system.

**Review the JACK RETRACTION section.**

Check that the vehicle is level when all the yellow LEVEL indicator lights are out.

Make sure the jacks will fully retract to the store position. Jacks should not interfere with any part of the vehicle when in the store position.

**NOTE:** The level sensing unit has an accuracy tolerance of + or - 1 inch side to side, and + or - 5.4 inches front to rear on a 36 foot vehicle.

With the jacks extended, check that the jacks can be retracted using the "T" handles on the solenoid valves. Refer to the MANUAL JACK RETRACTION section.

If the red LOW BATTERY indicator light comes on, the electrical system should be checked. Low voltage can cause erratic operation or damage to components. Contact your dealer or HWH CORPORATION for assistance.

---

# MAINTENANCE

---

## LEVEL SENSING UNIT ADJUSTMENT

Level the vehicle by placing a circular bubble level in the center of the freezer floor or location within the vehicle that is to be level. With the vehicle level, adjust the sensing unit until all yellow lights are off. This is done by drawing up the corresponding screw if the sensing unit is mounted below the surface, as shown, or backing out the corresponding screw if the sensing unit is mounted above the surface. Bump the sensing unit to see that it has settled down in the level position.

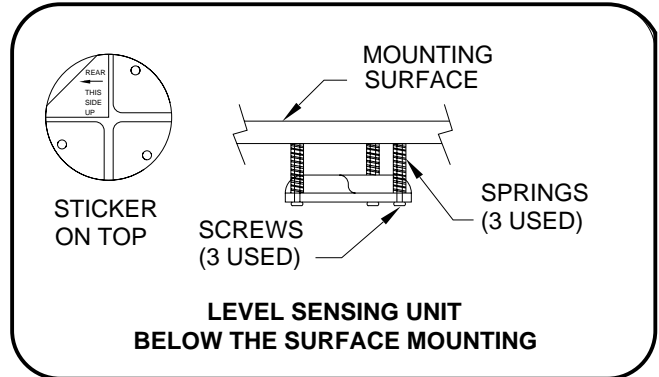

## "NOT IN PARK/BRAKE" CHECK

**CAUTION:** WHEN MAKING THIS CHECK, BLOCK THE VEHICLES WHEELS SECURELY SO THE VEHICLE CANNOT ROLL FORWARD OR BACKWARD.

Set the park brake. Switch the ignition to the "ON" position. Press the "HYD" button one time. Release the parking brake

and confirm that the "NOT IN PARK/BRAKE" indicator light comes on. Reset the parking brake. The "NOT IN PARK/BRAKE" indicator light should go out. Switch the ignition to "OFF".

**NOTE :** If any of the above checks or inspections reveal a problem or if there are other problems or questions, consult a qualified RV repair center, your vehicle or coach manufacturer, or HWH CORPORATION (1-800-321-3494) for service or repair.

---

# TROUBLE SHOOTING ROOM EXTENSION

---

The following is a list of problems, and possible solutions, which might occur to the room extension systems.

**NOTE :** Only qualified technicians should install or repair room systems. A knowledge of hydraulic, welding, the vehicle,s suspension and electrical systems is required. In addition, an understanding of the room extensions system,s hydraulics and electronics is required.

**1. HYDRAULIC PUMP WILL NOT ACTIVATE WHEN ROOM CONTROL SWITCH IS PRESSED.**

- A. KEY SWITCH is in the "OFF" POSITION.
- B. A JACK WARNING LIGHT is not on.
- C. FUSE is blown.
- D. PUMP RELAY and/or HYDRAULIC PUMP are not properly grounded.
- E. 12 VOLT power to pump relay not present.
- F. Faulty wire, electrical connection, KEY SWITCH, ROOM CONTROL SWITCH, PUMP RELAY, or PUMP MOTOR.

**2. HYDRAULIC PUMP ACTIVATES, BUT ROOM WILL NOT EXTEND.**

- A. EXTEND SOLENOID VALVE is not properly grounded.
- B. Reservoir oil supply is low.
- C. Hydraulic line is pinched or broken.
- D. Faulty wire, electrical connection, ROOM CONTROL SWITCH , EXTEND SOLENOID VALVE, HYDRAULIC PUMP, or HYDRAULIC CYLINDER.

**3. HYDRAULIC PUMP ACTIVATES, BUT ROOM WILL NOT RETRACT.**

- A. RETRACT SOLENOID VALVE IS NOT properly grounded.
- B. Reservoir oil supply is low.
- C. Hydraulic line is pinched or broken.
- D. Faulty wire, electrical connection, ROOM CONTROL SWITCH , RETRACT SOLENOID VALVE, HYDRAULIC PUMP, or HYDRAULIC CYLINDER.

**4. ROOM CREEPS OUT AFTER CLOSING.**

- A. "T" HANDLE on EXTEND SOLENOID VALVE is not closed completely.
- B. EXTEND SOLENOID VALVE has an internal leak.
- C. HYDRAULIC CYLINDER has an internal leak.
- D. The MANIFOLD CHECK VALVE is leaking.

**5. ROOM CREEPS IN AFTER BEING EXTENDED.**

- A. "T" HANDLE on RETRACT SOLENOID VALVE is not closed completely.
- B. RETRACT SOLENOID VALVE has an internal leak.

# HYDRAULIC CONNECTION DIAGRAM

## 500 SERIES, COMPUTER-CONTROLLED LEVELING SYSTEM WITH A DUAL CYLINDER ROOM EXTENSION WITH RACK SENSING VALVE

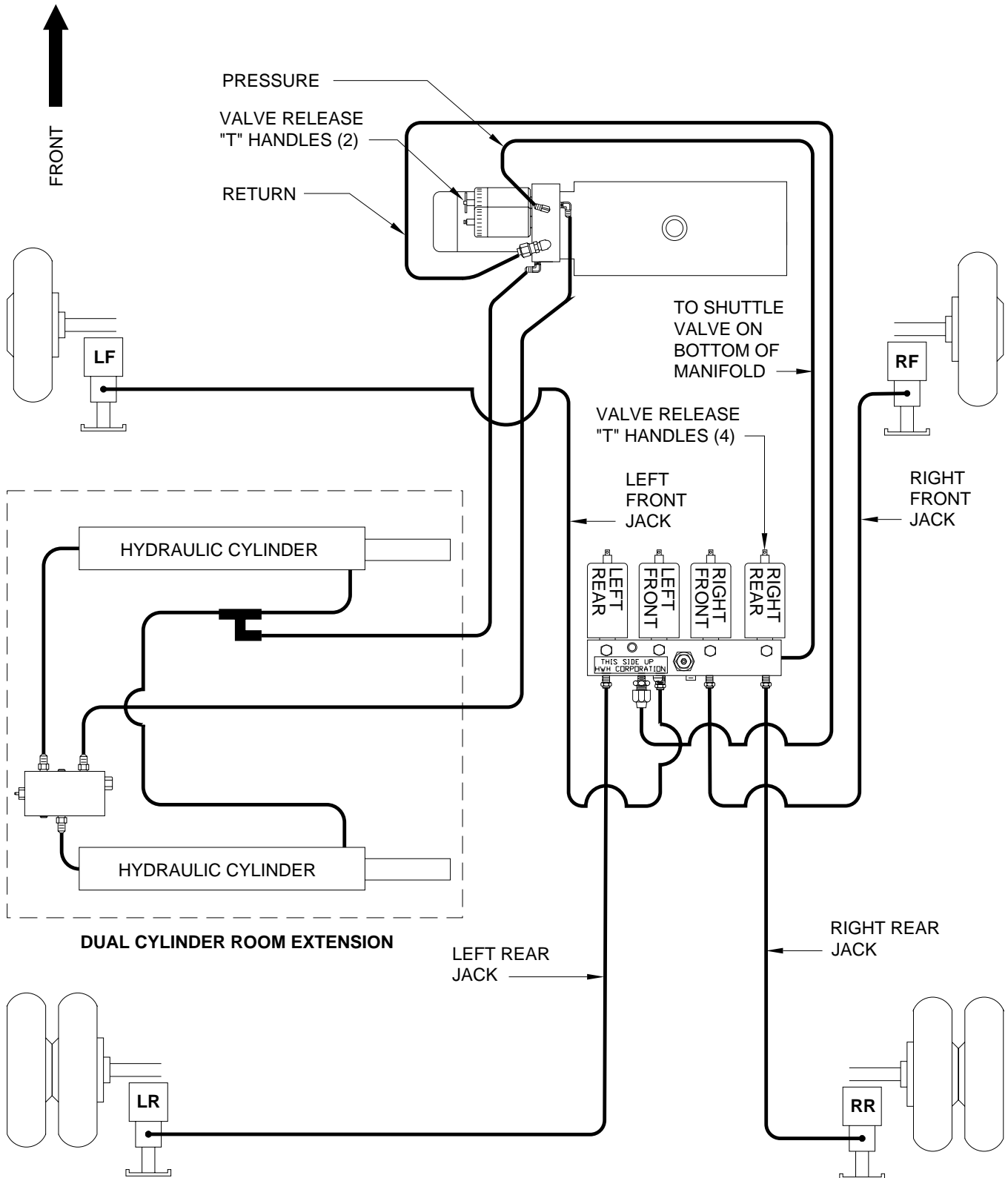

# HYDRAULIC SCHEMATIC WITH STRAIGHT-ACTING JACKS

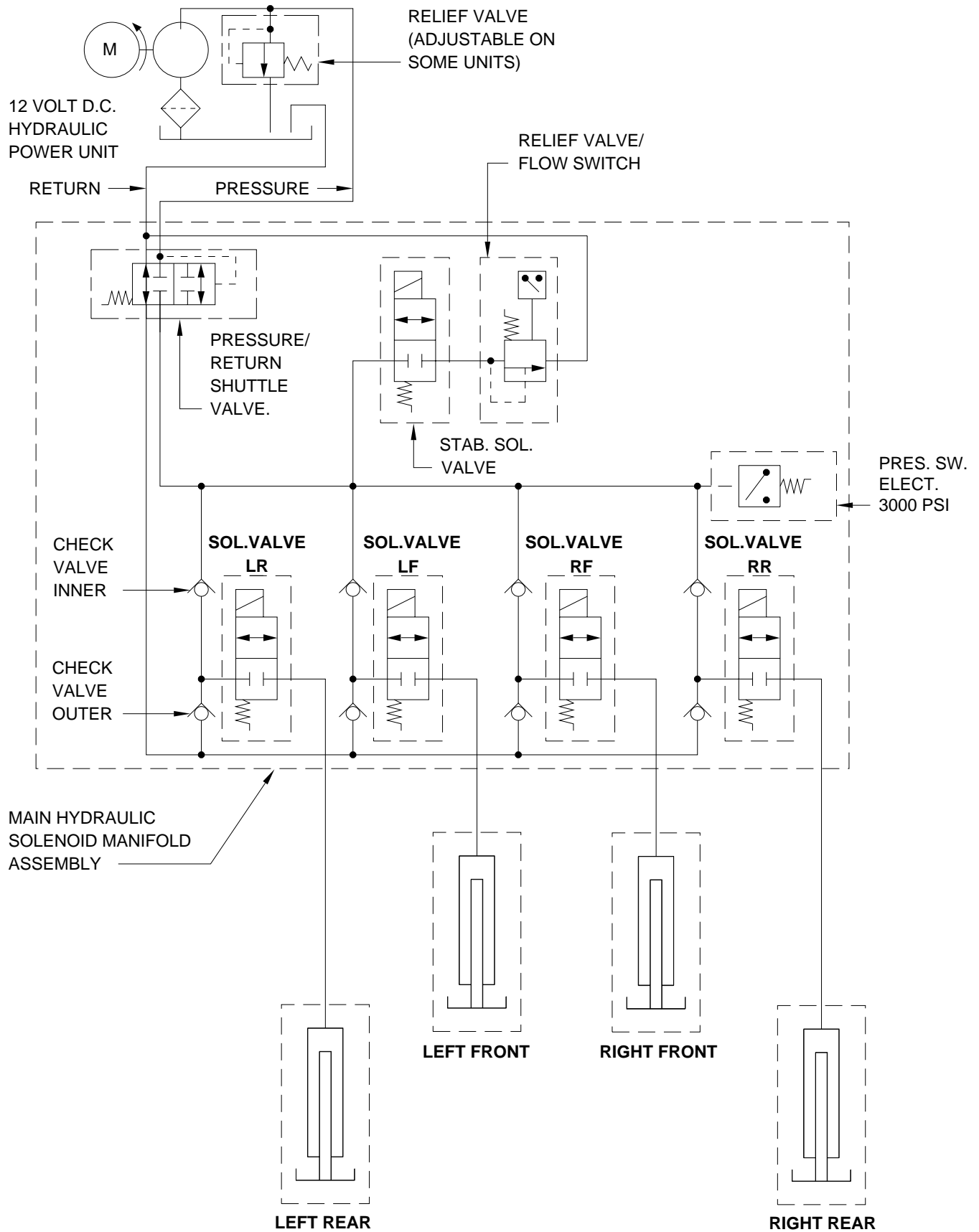

# HYDRAULIC SCHEMATIC DIAGRAM DUAL CYLINDER ROOM EXTENSION SYSTEM W/RACK SENSING VALVE

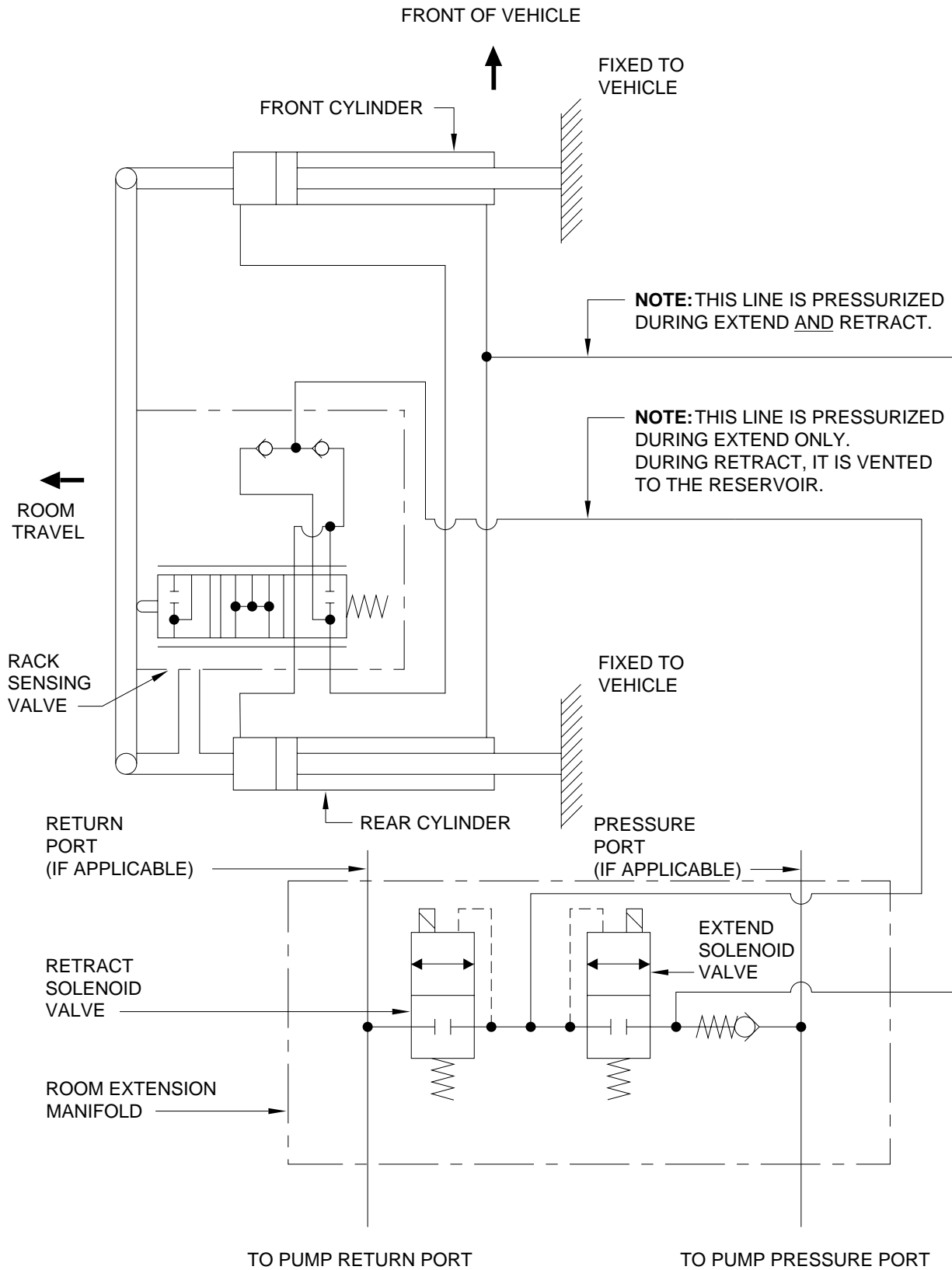



# AIR LINE CONNECTION DIAGRAM

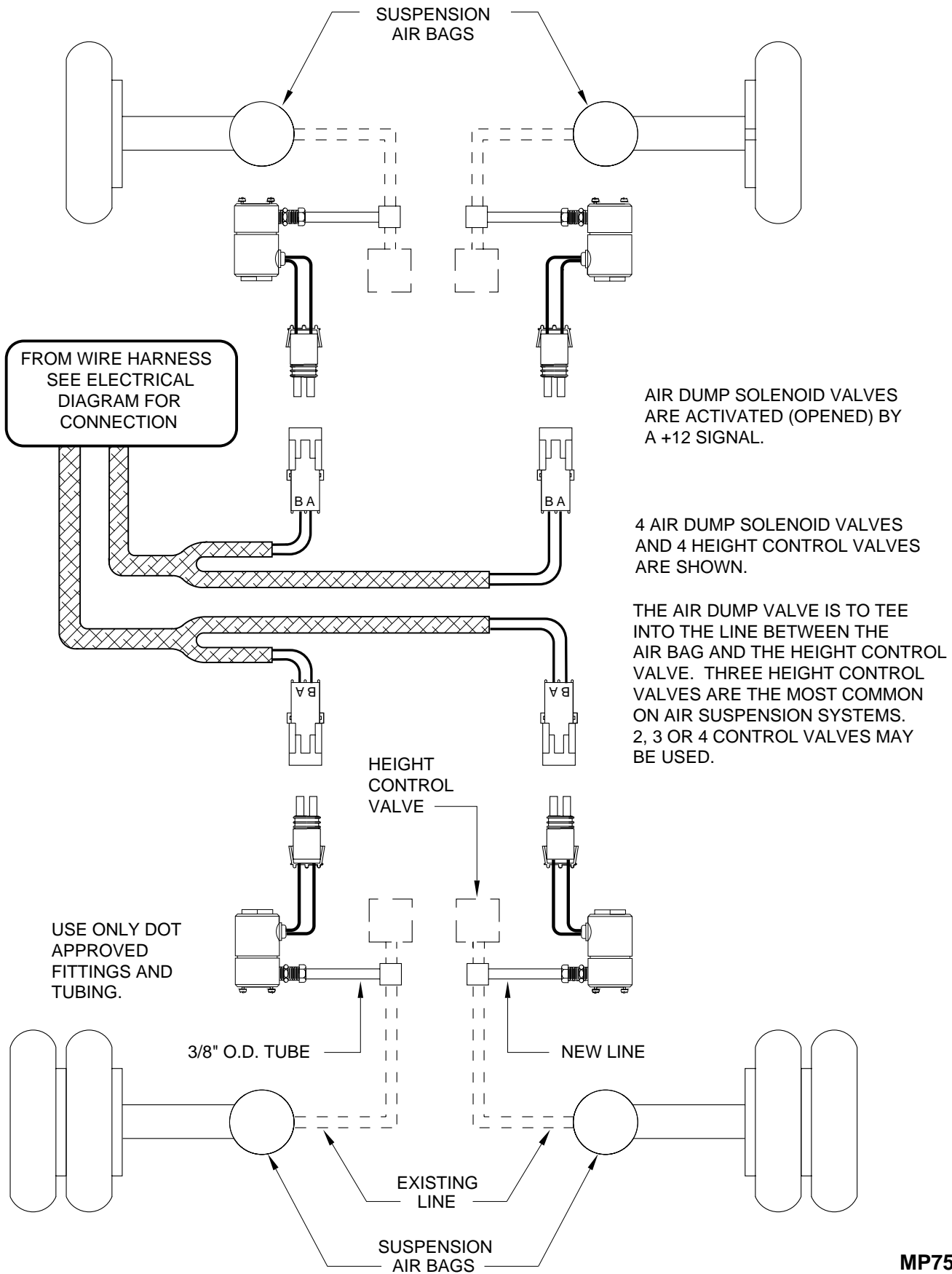

# CONTROL BOX CONNECTION DIAGRAM

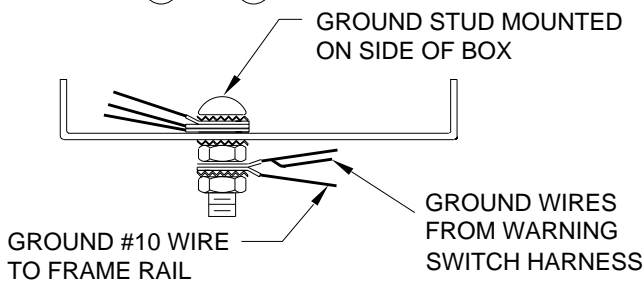
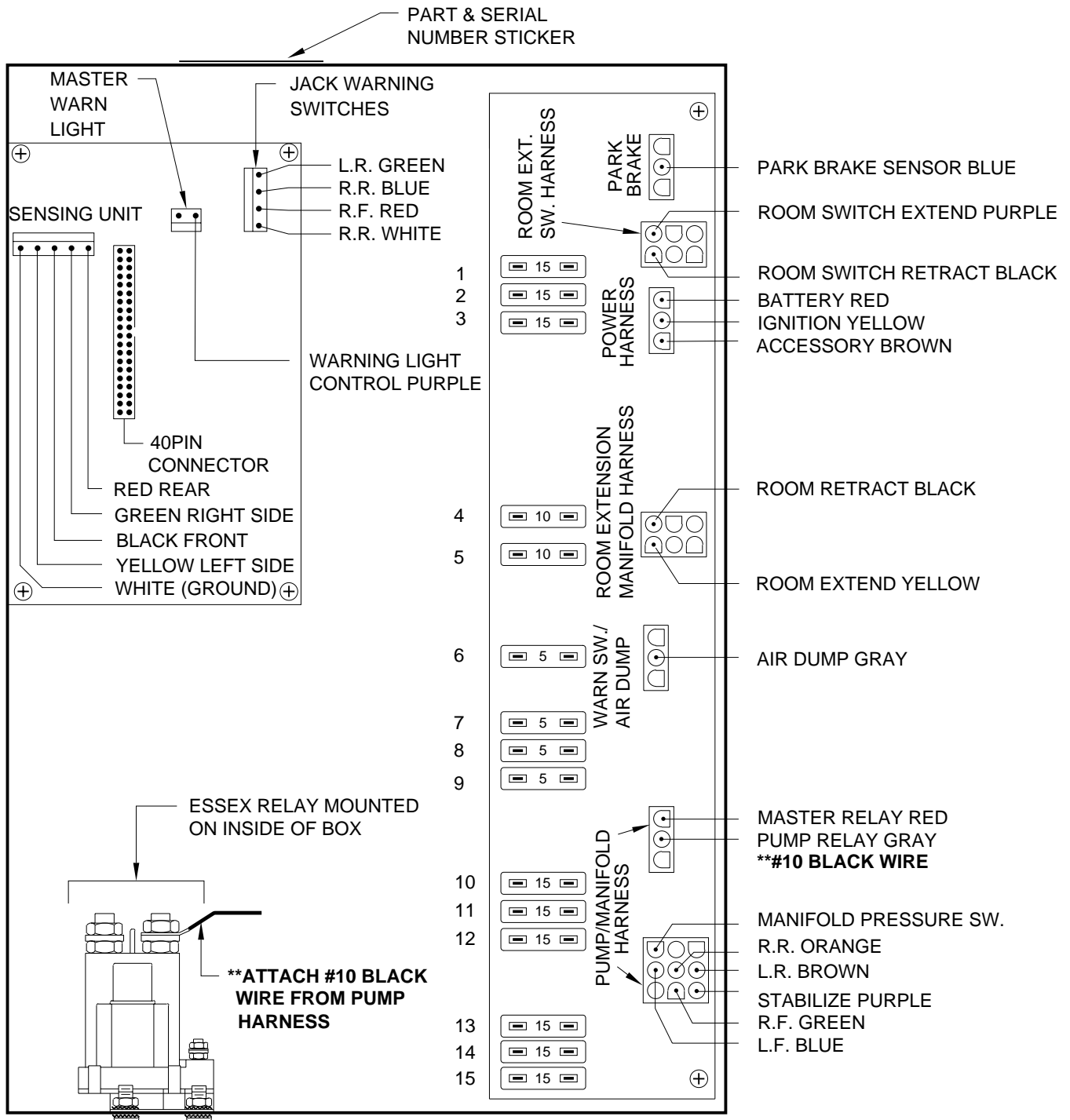

## FUSE DESIGNATION

- |                |                         |
|----------------|-------------------------|
| 1 BATTERY      | 9 PUMP                  |
| 2 IGNITION     | 10 RIGHT REAR SOLENOID  |
| 3 ACCESSORY    | 11 FUSE 15 AMP          |
| 4 ROOM RETRACT | 12 LEFT FRONT SOLENOID  |
| 5 ROOM EXTEND  | 13 RIGHT FRONT SOLENOID |
| 6 AIR DUMP     | 14 STABILIZE SOLENOID   |
| 7 PARK BRAKE   | 15 LEFT REAR SOLENOID   |
| 8 MASTER RELAY |                         |

# ELECTRICAL CONNECTION DIAGRAM COMPUTER-CONTROLLED HYDRAULIC LEVELING WITH TOUCH PANEL CONTROL

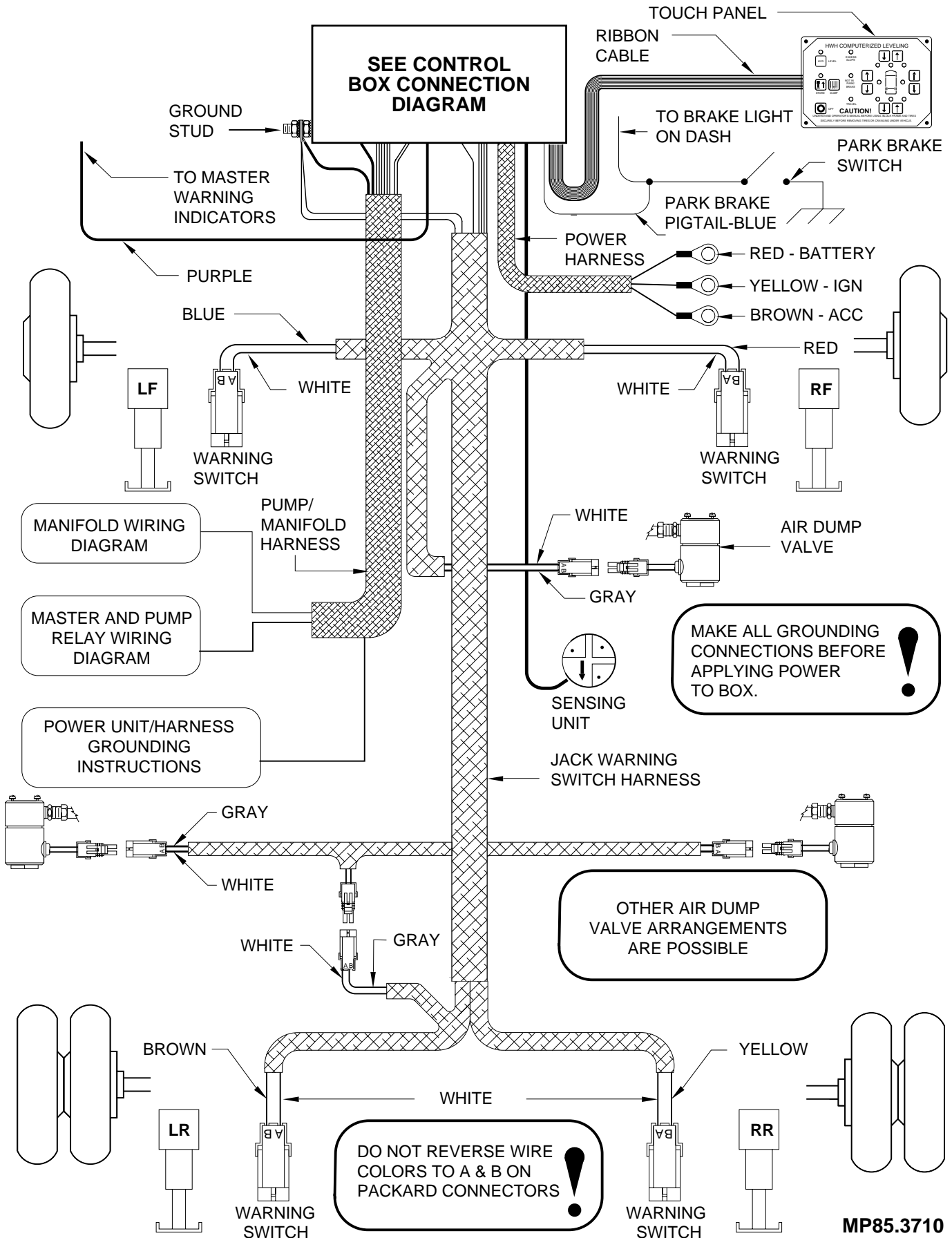

# WIRING DIAGRAM HYDRAULIC MANIFOLD FOR 500 SERIES LEVELING SYSTEMS

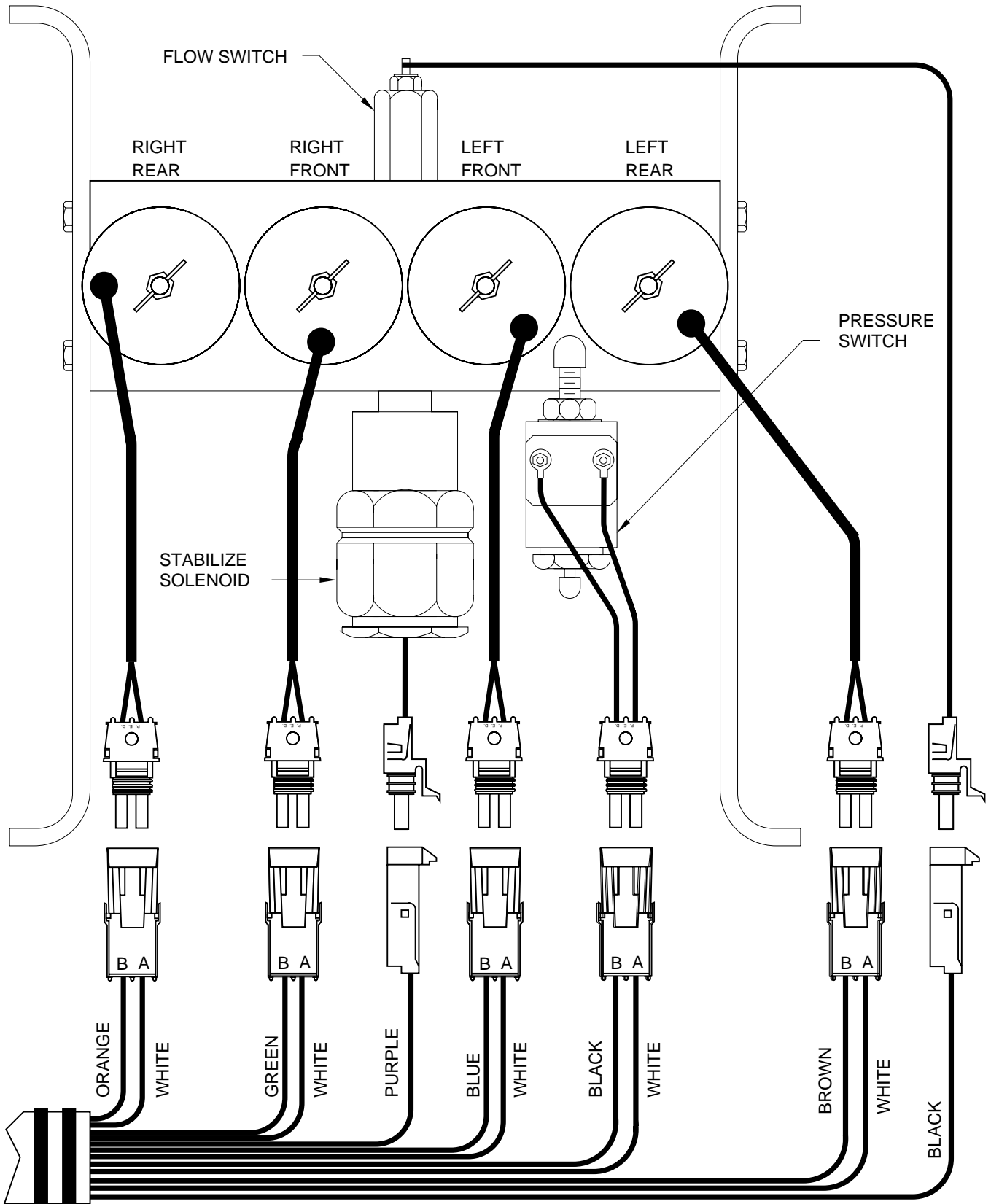

# ELECTRICAL CONNECTION DIAGRAM

## ONE ROOM EXTENSION SYSTEM

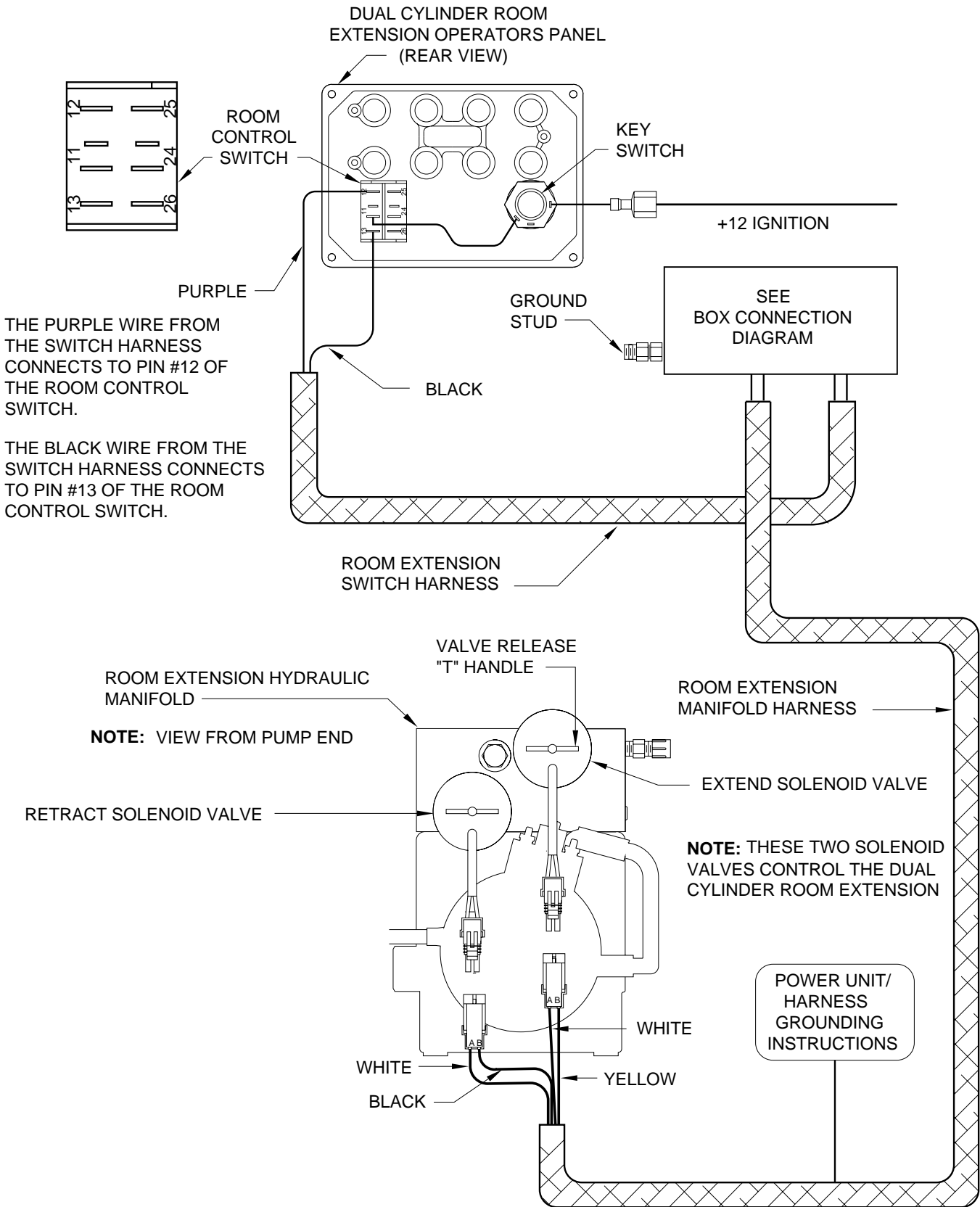

THE PURPLE WIRE FROM THE SWITCH HARNESS CONNECTS TO PIN #12 OF THE ROOM CONTROL SWITCH.

THE BLACK WIRE FROM THE SWITCH HARNESS CONNECTS TO PIN #13 OF THE ROOM CONTROL SWITCH.

# ELECTRICAL CONNECTION DIAGRAM MASTER AND PUMP RELAY FOR 610 SERIES LEVELING SYSTEMS

**NOTE:** THE (4) DIGIT WIRE NUMBER SUPERSEDES ANY AND ALL WIRE COLORS.

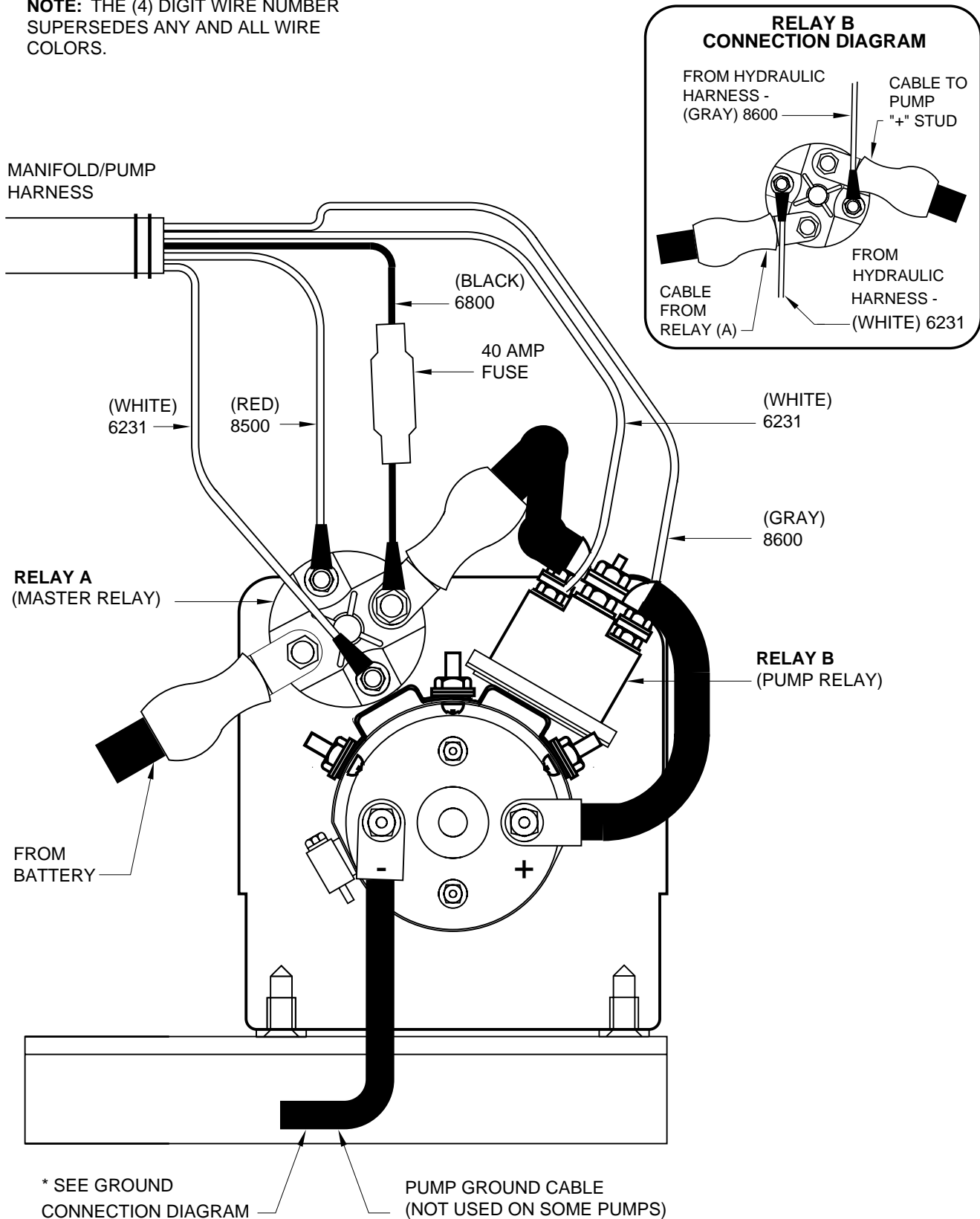

# GROUNDING INSTRUCTIONS POWER UNIT/HARNESS 610 SERIES LEVELING SYSTEM

## WELDED PUMP MOUNT

USE GROUNDING STUD AND 3/8" EXTERNAL STAR LOCKWASHERS AS SHOWN.

**IMPORTANT:** 3/8" STAR LOCKWASHER MUST BE USED BETWEEN GROUNDING SURFACE AND WIRE TERMINALS.

**NOTE:** THE (4) DIGIT WIRE NUMBER SUPERSEDES ANY AND ALL WIRE COLORS.

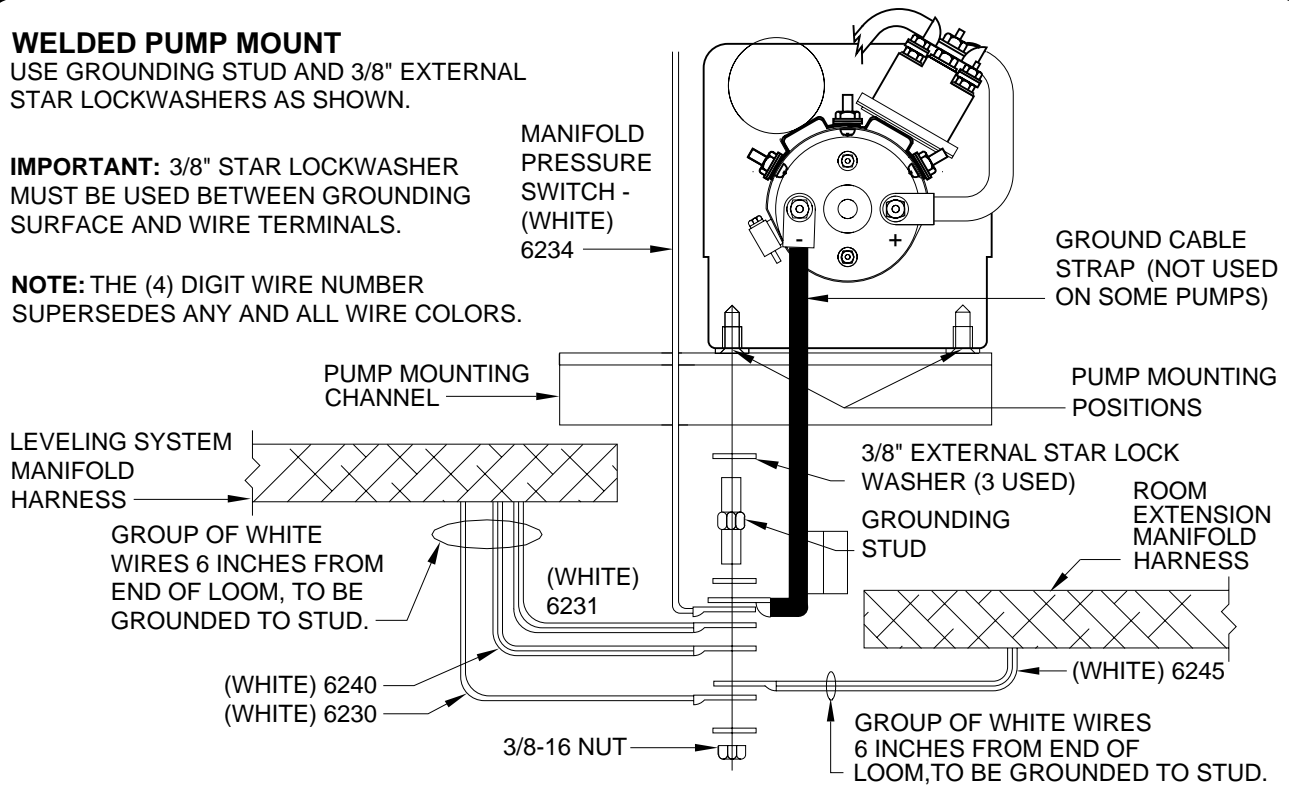

## PUMP MOUNTED REMOTE FROM FRAME

USE GROUNDING STUD AND 3/8" EXTERNAL STAR LOCKWASHERS AS SHOWN.

**IMPORTANT:** 3/8" STAR LOCKWASHER MUST BE USED BETWEEN GROUNDING SURFACE AND WIRE TERMINALS.

**NOTE:** THE (4) DIGIT WIRE NUMBER SUPERSEDES ANY AND ALL WIRE COLORS.

