

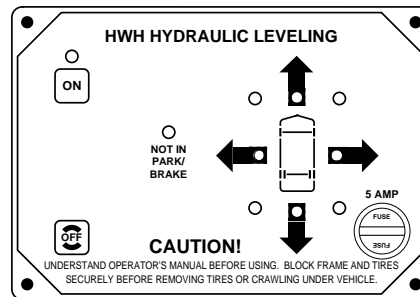

# INSTALLATION MANUAL

## HWH JOY STICK-CONTROLLED LEVELING SYSTEM 200 SERIES FOR MOTORHOMES

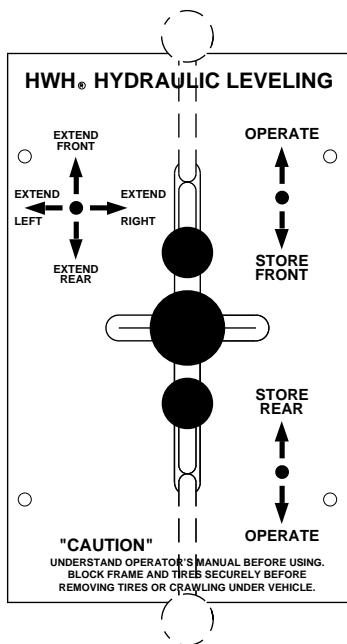

**HWH CORPORATION**  
**(ON I-80, EXIT 267 SOUTH)**  
**2096 MOSCOW ROAD**  
**MOSCOW, IOWA 52760**  
**(800) 321-3494 / (563) 724-3396**  
**INTERNET: <http://www.hwhcorp.com>**

---

# INSTALLATION MANUAL

## HWH HYDRAULIC LEVELING JACKS ON MOTOR HOMES

---

THE FOLLOWING INSTALLATION INFORMATION IS OFFERED AS SUGGESTIONS ONLY. VARIATIONS IN VEHICLE DESIGN, CHASSIS, SUSPENSIONS, TIRES AND COACH WEIGHTS MAKE IT IMPOSSIBLE TO ANTICIPATE AND ADDRESS ALL INSTALLATION PROBLEMS AND POSSIBILITIES. SOME VEHICLE BUILDERS OR CHASSIS BUILDERS MAY USE PRACTICES DIFFERENT FROM THOSE IN THIS MANUAL. CONSULT HWH CORPORATION OR THE VEHICLE BUILDER FOR INFORMATION CONCERNING CORRECT SYSTEM CAPACITY AND TYPE FOR THE VEHICLE, INSTALLATION QUESTIONS, AND INSTALLATION OF OTHER HWH EQUIPMENT.

ONLY QUALIFIED TECHNICIANS SHOULD INSTALL OR REPAIR LEVELING SYSTEMS ON VEHICLES. A KNOWLEDGE OF HYDRAULICS, WELDING, THE VEHICLE'S SUSPENSION AND ELECTRICAL SYSTEM, AS WELL AS AN UNDERSTANDING OF THE LEVELING SYSTEM'S HYDRAULICS AND ELECTRONICS IS REQUIRED.

**NOTE - HWH Corporation assumes no liability for  
damages or injuries resulting from the  
installation of this product.**

### **CAUTION !**

**READ THE ENTIRE INSTALLATION PROCEDURE BEFORE STARTING INSTALLATION.**

**BLOCK FRAME AND TIRES BEFORE CRAWLING UNDER VEHICLE. DO NOT USE LEVELING JACKS OR AIR SUSPENSION TO SUPPORT VEHICLE WHILE UNDER VEHICLE OR CHANGING TIRES. VEHICLE MAY DROP AND/OR MOVE FORWARD OR BACKWARD WITHOUT WARNING CAUSING INJURY OR DEATH.**

**DO NOT TURN ON POWER UNTIL INSTALLATION IS COMPLETE.**

**WHEN ROUTING HYDRAULIC HOSES AND WIRES, BE SURE THEY ARE NOT EXPOSED TO ENGINE EXHAUST OR ANY HIGH TEMPERATURE COMPONENTS OF THE VEHICLE.**

**KICKDOWN JACKS MAY ABRUPTLY SWING UP WHEN THE FOOT CLEARS THE GROUND OR WHEN JACK REACHES FULL EXTENSION.**

**NEVER PLACE HANDS OR OTHER PARTS OF THE BODY NEAR HYDRAULIC LEAKS. OIL MAY PENETRATE THE SKIN CAUSING INJURY OR DEATH.**

**SAFETY GLASSES ARE TO BE WORN TO PROTECT EYES FROM DIRT, METAL CHIPS, OIL LEAKS, ETC. FOLLOW ALL OTHER APPLICABLE SHOP SAFETY PRACTICES.**

**DO NOT OVER EXTEND THE REAR JACKS. IF THE WEIGHT OF THE VEHICLE IS REMOVED FROM ONE OR BOTH REAR WHEELS, THE VEHICLE MAY ROLL FORWARD OR BACKWARD OFF THE JACKS.**

---

# PART I

## PRE-INSTALLATION CHECKS

---

**THESE ARE ITEMS THE INSTALLER SHOULD CHECK BEFORE STARTING THE INSTALLATION:**

- 1.) Do the jacks have the proper capacity for the axle weights of the vehicle?
- 2.) Do the jacks have the proper stroke for the mounting heights available?
- 3.) Does the pump have the proper reservoir capacity for the jacks being used?
- 4.) Are acceptable mounting locations available for the jacks and other system components?
- 5.) Will the mounting brackets or jacks interfere with any vehicle components or structure?
- 6.) If the vehicle is equipped with a full air-bag suspension an air dump system must be used for proper leveling.

**NOTE :** Vehicles with supplemental air bags or suspensions such as JET AIR do not have to dump the air from the bags.

- 7.) Are all components necessary for the installation, including mounting brackets, hardware kits, hoses, etc. present?
- 8.) Does the vehicle need exhaust work done before the jacks are installed?
- 9.) Does the vehicle have a good set of batteries that are fully charged?

**NOTE:** Do not use kickdown style jacks and straight acting jacks on the same vehicle.

**IF THERE ARE ANY PROBLEMS WITH ANY OF THE ABOVE ITEMS, CONTACT HWH CORPORATION BEFORE STARTING THE INSTALLATION**

# PART II

## JACK INSTALLATION

### LOCATING THE JACKS

**1. MOUNTING BRACKETS:** HWH Corporation has bolt-on mounting brackets available for many different applications. (See "BRACKETS"-HWH Service Manual) Most of the brackets are designed to fit a specific chassis in a specific location. Slight modification of these brackets is acceptable but HWH Corporation should be contacted when modifying or changing the mounting locations of these brackets. The kick down brackets are designed for use with 6000# and 9000# jacks. Many vehicles requiring 16000# jacks are equipped with mounting brackets for these jacks. Contact HWH Corporation for mounting information when needed.

Most brackets are designed with specific bolt hole arrangements. Use of all holes, especially holes used for the fingers of the mounting bracket for the flanges of the frame rail, is important. When using brackets with multiple sets of bolt holes, use the widest possible pattern. Always bolt at the top and bottom of the frame rail whether using mounting brackets, or bolting straight acting jacks directly to the frame rail.

HWH Corporation does not suggest welding brackets or straight acting jacks to the frame rails. Do NOT weld kick down jacks to the mounting brackets or directly to the frame rail. (See Section B-WELDING) If it is necessary to modify the tailpipe, have the owner take the vehicle to a professional muffler shop for proper procedure before starting installation.

**2. MOUNTING ARRANGEMENT:** The correct mounting location for the jacks is important for the proper functioning of the leveling system. The jacks should be mounted as close as possible behind the front and rear axles. (See FIGURE 1) This will reduce stress in the vehicle and leveling system. When a tag axle is used the jacks should be mounted between the drive axle and the tag axle. Mounting the front jacks in front of the axle is not suggested. (See FIGURE 2) Contact HWH Corporation or the coach manufacturer before mounting the front jacks in front of the front axle.

Kick down style jacks must be mounted so that they swing up towards the rear of the vehicle when retracted. Mounting the jacks in other positions as shown in FIGURE 4 is not suggested. Mounting jacks that will fold toward the front as in FIGURE 3 is unacceptable.

**3. JACK MOUNTING HEIGHT:** When figuring proper mounting heights or locations refer to the Clearance and Mounting Dimensions Charts. Combining these dimensions and information supplied on the "JACK BRACKET" sheets (See "BRACKETS"-HWH Service Manual) will make it possible to figure proper mounting heights and locations before starting the installation. In most cases these mounting heights will provide clearance on uneven terrain and permit the placement of a pad under the jacks when operating on soft ground or asphalt. (Pads are available from HWH Corporation)

**Vehicles with spring suspension:** The ground clearance shown on the Dimension Charts apply to vehicles with a full load of fuel, water and equipment. When empty add 1" to these dimensions. Also take into consideration that new vehicles can settle down 3/4" or more during the first year or initial 10,000 miles.

**Vehicles with full air bag suspensions:** HWH Corporation suggests using straight acting jacks on vehicles with full air bag suspension. The vehicle should be at the proper ride height when determining the proper mounting heights for the jacks. If kick down style jacks are used, add 2 inches to the suggested jack mounting heights.

**CAUTION:** VEHICLE WILL RAPIDLY DROP SEVERAL INCHES IF AIR BAGS DEFLATE. DEFLATE AIR BAGS BEFORE WORKING UNDER THE VEHICLE.

**4. DEFLATING AIR BAGS:** Before deflating the air bags the vehicle's frame must be securely blocked. The air can be released by disconnecting the air line between the height control valve and the air bag. Usually the fitting at the height control valve is easiest to get to. (See the SUSPENSION AIR DUMP DIAGRAM)

**IMPORTANT:** When the air is released the bags will deflate quickly. Make sure there is adequate clearance to work under the coach.

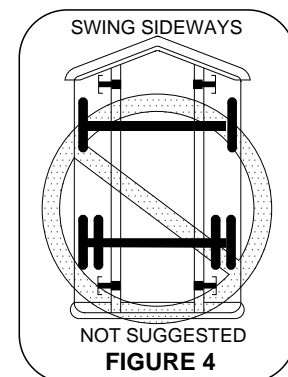
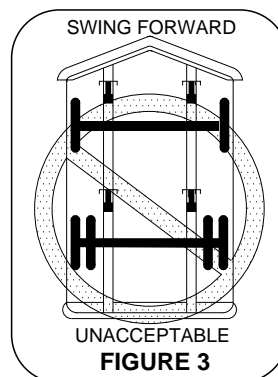
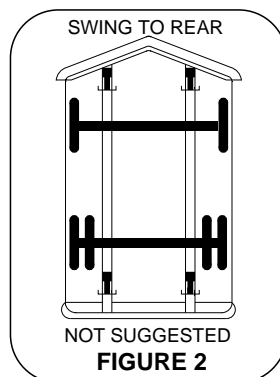
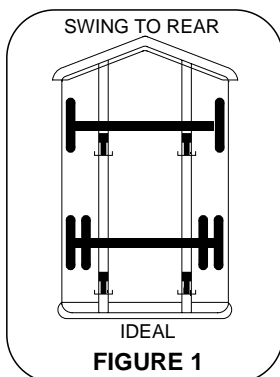

---

## PART II

# JACK INSTALLATION

---

**4. MOUNTING LOCATIONS** : Refer to the CLEARANCE AND MOUNTING DIMENSIONS CHARTS for specific measurements.

Some general mounting location suggestions are:

- 1.) Rear jacks should always be mounted behind the drive axle.
- 2.) Do not mount rear jacks on frame extensions.
- 3.) Jacks should be mounted near frame cross members.
- 4.) When frame cross members are not close the jack brackets should be tied together with a cross member.
- 5.) Front or rear jacks may be staggered several inches to accommodate vehicle equipment and compartments.
- 6.) Front jacks and mounting brackets must be mounted so they do not interfere with suspension components when retracted or extended.
- 7.) Front jacks and mounting brackets must be mounted so they do not interfere with tires when turned stop to stop.

**IMPORTANT:** Clearance **MUST** be provided for kick down jacks to extend fully in the horizontal position to prevent serious damage to the vehicle.

**NOTE:** When using straight acting jacks, the rear jacks on all installations must be tied together. Straight acting jacks on the front of vehicles with a raised rail chassis such as Spartans must be tied together. If using straight acting jacks, it is suggested the front jacks on all installations be tied together when possible.

Be sure jacks, jack mountings, or mounting brackets do not interfere with any moving components on the vehicle such as axles, springs, air bags, steering linkage, etc. Kick down jacks may need to be adjusted to allow full extension of the jack in the horizontal position.

**HWH Corporation assumes no liability for damages to the vehicle or jack resulting from jack extension in the horizontal position.**

Jacks must NOT be exposed to high temperatures such as exhaust pipes. If exhaust pipes need to be moved, this should be done before installing the leveling system. Heat shields supplied with HWH brackets should be applied to both sides. After-market exhaust systems may be added at a later date exposing jacks to high temperatures.

# PART II

## CLEARANCE AND MOUNTING DIMENSION CHART

### KICK - DOWN JACKS

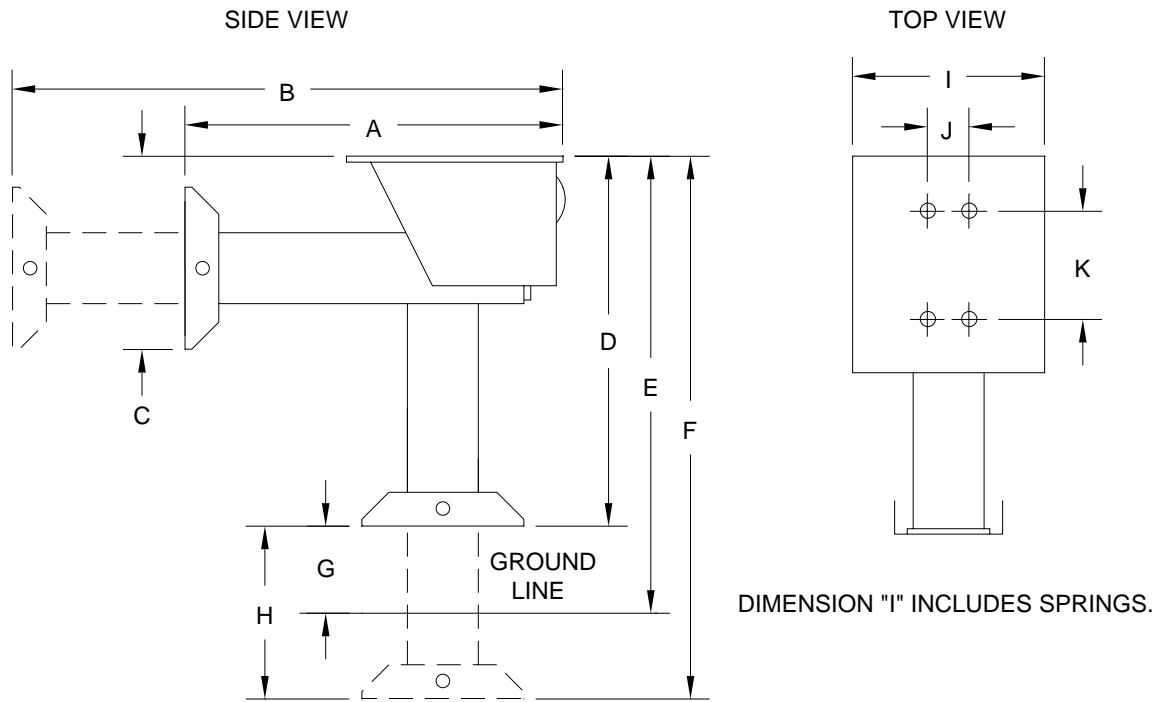

JACK	RETRACTED DIMENSIONS			EXTENDED DIMENSIONS				STROKE	MOUNTING WIDTH	MOUNTING BOLT PATTERN	
	A	B	C	D	E	F	G			H	I
6000# SHORT	12.5"	19.5"	4.5"	12.0"	MIN 14.0" MAX 16.0"	19.0"	MIN 2.0" MAX 4.0"	7.0"	6.5"	1.5"	4.5"
6000# TALL	14.0"	22.0"	4.5"	13.5"	MIN 15.5" MAX 17.5"	21.5"	MIN 2.0" MAX 4.0"	8.0"	6.5"	1.5"	4.5"
9000# SHORT	14.5"	23.0"	6.5"	13.5"	MIN 16.5" MAX 18.0"	22.0"	MIN 3.0" MAX 4.5"	8.5"	8.5"	1.5"	4.5"
9000# TALL	15.5"	24.5"	6.5"	14.5"	MIN 17.5" MAX 19.0"	23.5"	MIN 3.0" MAX 4.5"	9.0"	8.5"	1.5"	4.5"
16000#	18.0"	26.0"	7.0"	16.75"	MIN 19.75" MAX 21.25"	24.75"	MIN 3.0" MAX 4.5"	8.0"	12.5"	4.0"	4.0"

Dimension E is the suggested mounting height.

Dimension G is the suggested ground clearance when the jack is vertical but not extended.

\* If using kick - down jacks on vehicles with full airbag suspensions, add 2 inches to this dimension.

# PART II

## CLEARANCE AND MOUNTING DIMENSION CHART

### STRAIGHT ACTING JACKS

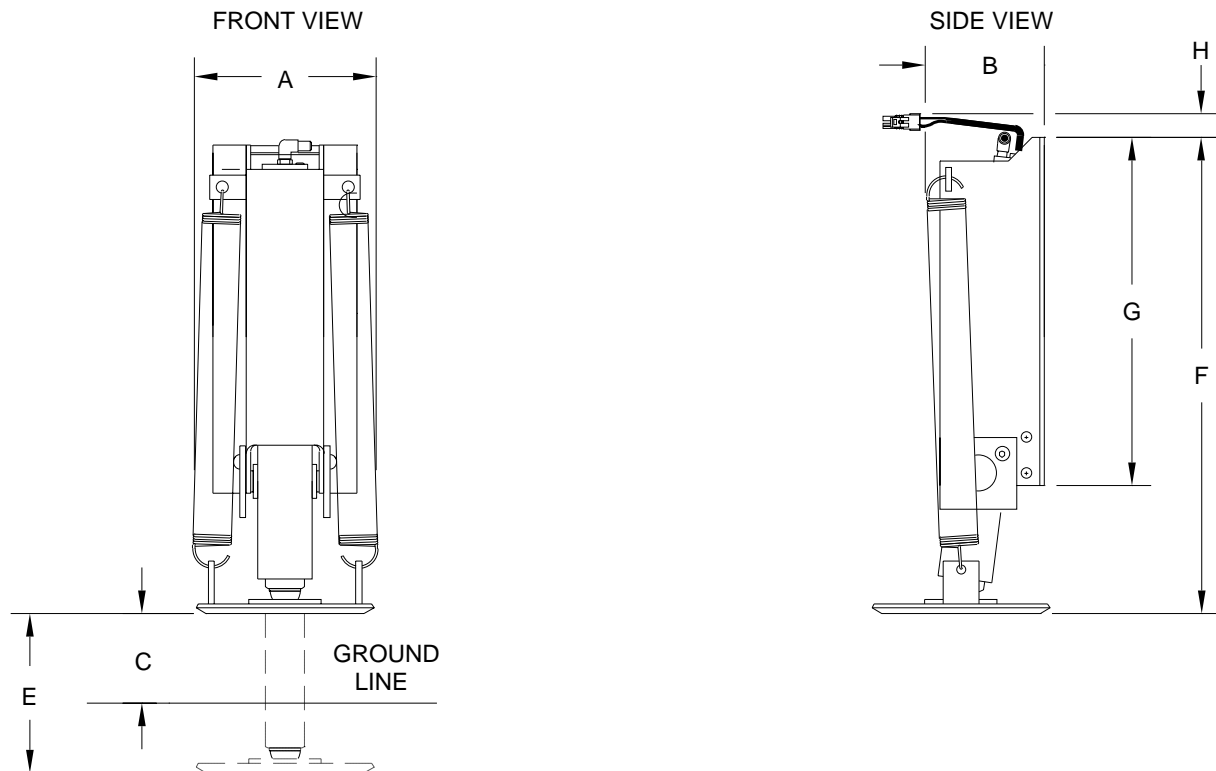

JACK	MOUNTING WIDTH		GROUND CLEARANCE	STROKE	RETRACTED HEIGHT	BRACKET HEIGHT	TOP CLEARANCE
	A	B					
AP2025 AP2026 CHEVY P-30 FRONT	CALL HWH CORPORATION						
AP0468** FORD OSKOSH-X FRONT	8.0"	4.9"	8.0" MIN 10.0" MAX	13.0"	19.5"	14.5"	0.5"
A-P1197** 6000# X 13"	8.0"	4.9"	8.0" MIN 10.0" MAX	13.0"	22.5"	17.5"	0.0"
AP1152 6000# X 16"	8.0"	4.9"	8.0" MIN 10.0" MAX	16.0"	22.5"	17.5"	0.5"
AP10466** CHEVY & FORD REAR ONLY	9.4"	6.0"	8.0" MIN 10.0" MAX	13.0"	20.0"	17.3"	0.0"
AP9551** 9000# x 13"	9.4"	6.0"	8.0" MIN 10.0" MAX	13.0"	21.7"	17.0"	0.0"
AP0154 9000# x 16"	9.4"	6.0"	8.0" MIN 10.0" MAX	16.0"	25.8"	21.0"	0.0"
AP9552** 12000# X 13"	9.5"	6.0"	8.0" MIN 10.0" MAX	13.0"	21.9"	17.0"	0.8"
AP9809 12000# X 16"	9.4"	6.0"	8.0" MIN 10.0" MAX	16.0"	25.9	21.0"	0.0"
AP9553** 16000# X 13"	12.0"	7.0"	8.0" MIN 10.0" MAX	13.0"	22.0"	17.0"	1.6"
AP9823 16000# X 16"	12.0"	7.0"	8.0" MIN 10.0" MAX	16.0"	28.5"	23.5"	0.0"

\* Take into account clearance for other coach equipment when determining mounting heights.

\*\* When mounting 13" stroke jacks on coaches with spring suspensions, using 8.0" of ground clearance.

---

# PART II

## JACK INSTALLATION

---

### WELDING

HWH Corporation does not suggest welding brackets to the frame rails. However, if any welding is done such as modifying a jack bracket already mounted, the following precautions should be observed:

Connect welding ground to part being welded. NEVER weld to suspension parts such as spring shackles. NEVER weld across the bottom flange of the frame rail. Brackets should be located near a cross member. For additional information on the vehicle, chassis, brackets, and mounting location, contact the vehicle's builder, the chassis or suspension supplier, or HWH Corporation.

**IMPORTANT:** There may be fuel lines or wire inside the frame rail. They should be well protected from the heat caused by welding. Damage or personal injury could occur. The following are welding precautions for specific chassis manufactures:

#### 1. G.M.

Disconnect both battery cables. ALWAYS DISCONNECT THE GROUND CABLE FIRST.

Disconnect computer module wiring.

Attach the welding ground to the part to be welded.

Do not use suspension components as ground points.

Keep welding cables away from electrical systems.

#### 4. GILLIG

Disconnect both battery cables. ALWAYS DISCONNECT THE GROUND CABLE FIRST.

Attach the welding ground to the part to be welded.

Do not use suspension components as ground points.

Keep welding cables away from electrical systems.

#### 2. FORD

Disconnect both battery cables. ALWAYS DISCONNECT THE GROUND CABLE FIRST.

Disconnect computer module wiring.

Attach the welding ground to the part to be welded.

Do not use suspension components as ground points.

Keep welding cables away from electrical systems.

#### 5. SPARTAN

Disconnect both battery cables. ALWAYS DISCONNECT THE GROUND CABLE FIRST.

Attach the welding ground to the part to be welded.

Do not use suspension components as ground points.

Keep welding cables away from electrical systems.

#### 3. OSH KOSH

Disconnect both battery cables. ALWAYS DISCONNECT THE GROUND CABLE FIRST.

Attach the welding ground to the part to be welded.

Do not use suspension components as ground points.

Keep welding cables away from electrical systems.

**NOTE:** Check with the chassis manufacturer for the most recent information on welding precautions.



---

## PART III

# COMPONENT INSTALLATION

---

**1. LOCATING THE VALVE:** The valve is normally placed to the left of the driver's seat. This location is not vital but is most convenient. If the need arises the valve can be put elsewhere such as alongside the couch or chair. Be sure to check underneath to see that the bottom of the valve will be accessible. It is not advisable to put the valve in a compartment or in the dash.

**NOTE:** If the valve is to be put near the left front tire, care should be taken to keep it as far outboard and rearward as possible. If mounted too close to the tire, the valve may be struck by the tire on rough or bumpy roads or when turning.

**2. MOUNTING THE VALVE:** The joystick valve (200 Series) requires a 3.25 inch by 7.00 inch hole cut at the desired location. The valve should be mounted so that the front and the aft movement of the control lever is in line with the coach. Be sure there is adequate clearance for full movement of all levers. Before cutting the hole, be sure to check underneath for wiring, structural parts, or other items that may create a problem. Also be sure to leave enough room to connect all hydraulic hoses.

**NOTE:** Do not remove fitting caps until attaching the hose to the valve.

The joystick (200 Series) light panel may be flush mounted in a flat surface such as the dash or may be surface mounted on the floor or other convenient locations by using the 1.75" tall spacer box. When surface mounting the light panel adjacent to the valve be sure to orientate the panel so the yellow lights coincide with the coach. Drill a 1" hole beneath the light panel to pass the wiring through. Do not mount the light panel until all wiring is complete. Always leave enough wire length in the spacer box to allow lifting the panel for repair. Be sure to seal the 1" hole when finished. Never flush mount a panel in the floor. The panel must always be protected from dirt and water. When flush mounting the light panel, a rectangular hole with 45 degree corners matching the back of the panel will need to be cut in the mounting surface. (See Template at the end of Part III.) There must be a minimum clearance of 2" behind the mounting surface to allow for the panel and the wiring.

The joystick valve (200 Series) will drop through the hole from the top. Secure valve and cover plate at the same time using four #10 x 3/4" Phillips head screws. Caulk around the underside of the valve where the box meets the floor.

**3. LOCATING AND MOUNTING THE PUMP:** Although it is not always possible, it is desirable to put the pump assembly under the hood compartment where it is easily accessible for service or fluid check and refill. The distance of the pump from the valve is limited by the 7' hose provided and the battery cable although a longer hose and cable may be used if available. The pump and pump relay should be protected from direct road dirt.

**4. HYDRAULIC HOSES:** It is important to keep the ends of the hoses plugged during installation to prevent any dirt from entering the system. Hoses should be routed away from any heat emitting items such as engine or exhaust components. A good location is along the outside of the frame rail. It may be necessary to build a heat shield and/or adequately insulate the hoses. Care should be taken to avoid sharp edges.

**Tightening of hose ends: If tightening a new hose end, make the hose end snug (finger tight) on the fitting, then tighten the hose end 1/3 turn (2 FLATS). If tightening an existing hose end, tighten the hose end to snug plus 1/4 turn (1 FLAT).**

**IMPORTANT: Do not attach hoses or wiring to any fuel or brake lines. Do not run hoses across the transmission crossmembers on front control coaches.**

**CAUTION:** A LEAKING HOSE CAN POSE A FIRE HAZARD.

**NOTE:** When connecting hoses and wiring harnesses to the kick down jacks always check that the jack can swing from the horizontal position to a position 45 degrees beyond the vertical position, without kinking the hose or without tight wires. The jack must also be able to freely fold back to its stored position.

**EXTREME CAUTION:** A KICK DOWN JACK WILL SWING UP ABRUPTLY WHEN IT IS RELEASED.

**Straight Acting Jacks:** Can pivot several inches. Hoses and wiring harnesses must have enough slack to allow free movement of the jack.

There are different lengths of hoses to be routed to the four leveling jacks. (Refer to the Hydraulic Hookup Diagram)

**Straight Acting Jacks:** Route the hose to the top of the jacks and connect it to the hose fitting. 90 degree swivel fittings are available if needed for clearance.

# PART III

## COMPONENT INSTALLATION

### KICK DOWN JACKS:

**6000# KICK DOWN JACK-** A short hose is attached to the jack at the factory. The hose is clamped to the pivot bracket. It can be moved to the opposite side of the jack if necessary to avoid heat sources or other obstacles.

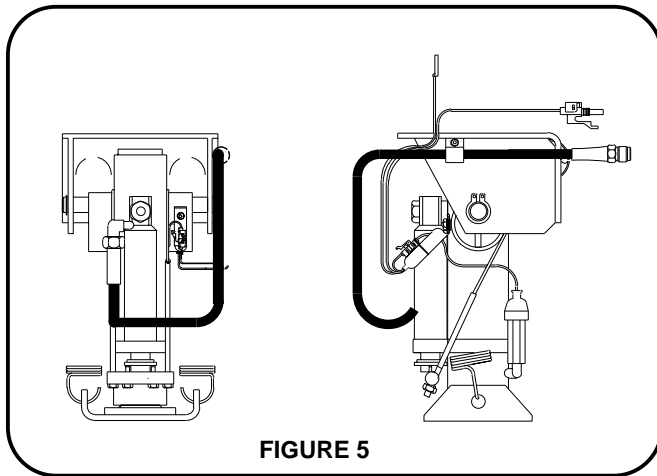

**16000# KICK DOWN JACK-** Route the hose around the left pivot, then across the back side of the cylinder and connect to the actuator fitting. Attach the hose to the pivot bracket using a hose clamp. There should be no slack in the hose.

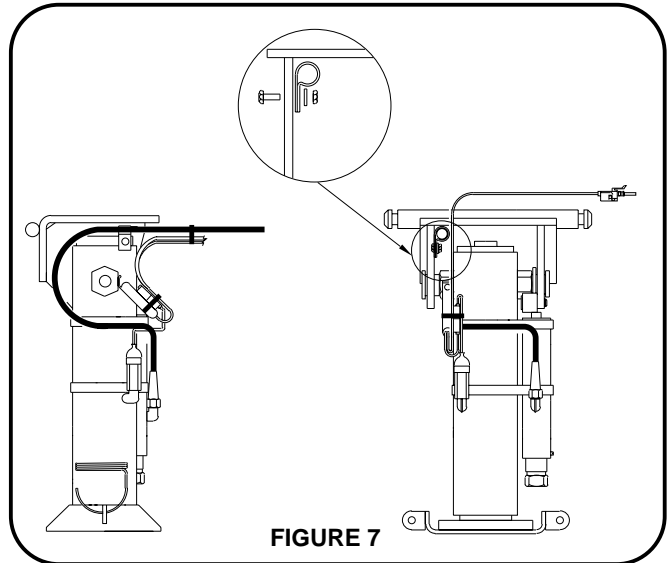

**9000# KICK DOWN JACK-** When connecting the hose to the jack, the hose should go in the upper left-hand corner, over the pivot area and down the front of the jack. After connecting the hose to the fitting, the hose should be clamped with a 1/4" bolt to the left side of the pivot bracket. Be sure the hose is snug against the jack in the retracted (horizontal) position.

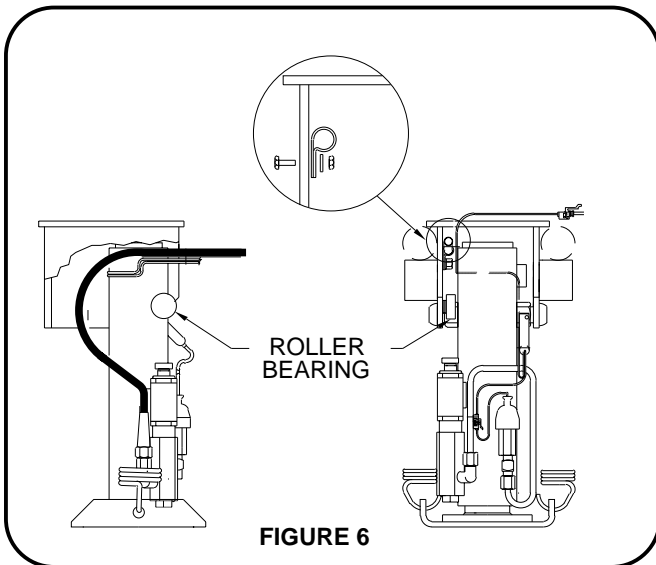

## PART III

# COMPONENT INSTALLATION

**5. WIRING:** Refer to the appropriate electrical diagram for wiring. Any wire or cable in the interior of the coach is to be protected by fusing. All wire insulation should be rated 125 deg. Celsius (257 deg. F). Check applicable RVIA or other code for detailed fusing and wiring information. Protecting all wires and cables by fusing is desirable.

A #2 battery cable is supplied with most systems to connect the pump to the battery or a battery junction post. If a different cable is used it must be able to carry 200 amperes. If fusing is required, use a 200 ampere fuse. The fuse should be placed near the power source. Never connect a fuse directly to the battery or place it in the battery box where an electrical spark can cause the battery to explode. If power is taken directly from the battery, the fuse should be at least 18" from the battery. A fuse kit is available from HWH Corporation.

Wiring harnesses supplied are usually adequate for most installations. Harnesses are loomed at the factory. All connections are plug in type except for pump relay which has ring terminal connections and the power supply for the panel. That is a field connection made by the installers.

If lengthening or shortening the harness is necessary it is suggested that all connections be soldered and protected with shrink tube. If other connection devices are used they must be sealed to prevent deterioration of the connection. Grease-filled weather resistant crimp on butt connectors are available .

**NOTE:** Packard Connectors are marked with A & B for wire connections. This cannot be mixed up. Maintain correct wire size and color when altering harnesses.

Master Warning Light/Buzzer connections are done by the installer. Route all wiring away from all heat sources and protect against sharp edges. Check that jacks can pivot properly without cutting or stretching wire harnesses or connections. All grounding connections are supplied by HWH Corporation and all grounding should be done at the supplied ground stud. (Refer to PUMP RELAY AND PANEL CONNECTION DIAGRAM). Coat all exposed electrical connections (battery cable ends, pump solenoid terminals, grounds, etc.) with a protective sealant such as Kraylon 1307.

**IMPORTANT:** THE BLUE PARK BRAKE WIRE IS A SAFETY FEATURE AND MUST BE HOOKED UP ACCORDING TO THE WIRING DIAGRAMS.

**6. PARK BRAKE CONTROL WIRE:** The blue wire should supply a ground signal or a +12 signal to the light panel only when the park brake is applied. The blue wire is a single, loomed wire in a separate plug at the light panel. The plug is wired for a ground signal park brake switch.

**GROUND SIGNAL PARK BRAKE:** The existing wire to the park brake switch is cut and routed to the connectors on the end of the blue park brake wire harness. The connectors are labeled and must be connected accordingly for the system to function properly. Protect the connections with the shrink tube

that is supplied. Other wire terminals may be used on the end of the harness but DO NOT eliminate the diode arrangement. (See FIGURE 8)

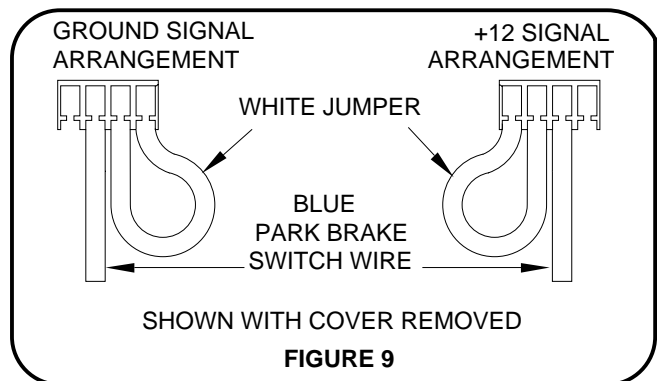
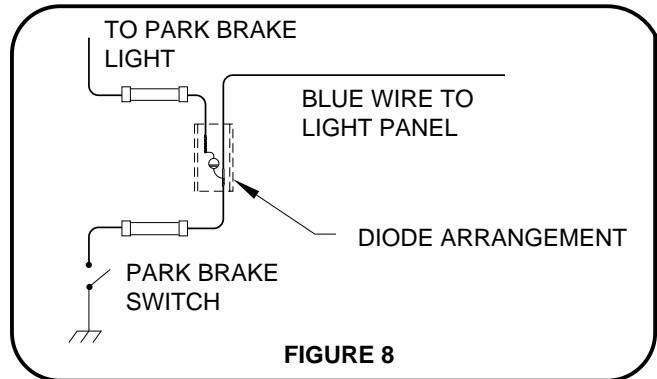

**+12 PARK BRAKE:** Eliminate the diode arrangement at the end of the blue park brake wire. (FIGURE 8) Splice the blue wire directly onto the wire from the park brake switch. Soldering with shrink tube is the preferred way to make this connection. A different park brake harness may be ordered for +12 park brake installations or the original plug can be rewired to work correctly. (See FIGURE 9)

**7. THE MASTER WARNING LIGHT/BUZZER:** A Master Warning Light should be used with all systems. A buzzer must be used with systems using straight acting jacks. The Master Warning Light should be mounted in the dash in a location highly visible to the driver. This light will warn the driver if any of the jacks are down when the ignition is turned to "ON". Drill a 1/2" hole at the desired location. Be sure to check for wires or other devices behind the surface before drilling. When installing the light itself, make sure the ignition is in the "OFF" position. With the ignition on +12 can be present at the warning light.

When using a buzzer, the +12 power should come from the "ON" side of the ignition switch. The power for the panel should come from the "ACC" side of the ignition switch. (Refer to the MASTER LIGHT/BUZZER CONNECTION DIAGRAM). With all wiring complete, the light plate may now be mounted.

## PART III

# COMPONENT INSTALLATION

**8. MOUNTING THE SENSING UNIT:** The Level Sensing Unit can be mounted above or below the surface as long as the "This Side Up" sticker (FIGURE 10) is facing up and the "Rear" arrow is pointing to the rear of the coach. The sensing unit must be mounted to a solid surface that will not flex. Do NOT mount the sensing unit near any heat-emitting items. Outside of the frame rails is preferred. The sensing unit must be at least 12" away from exhaust pipes or other high temperature components, and must not be in line of sight from these high temperature components.

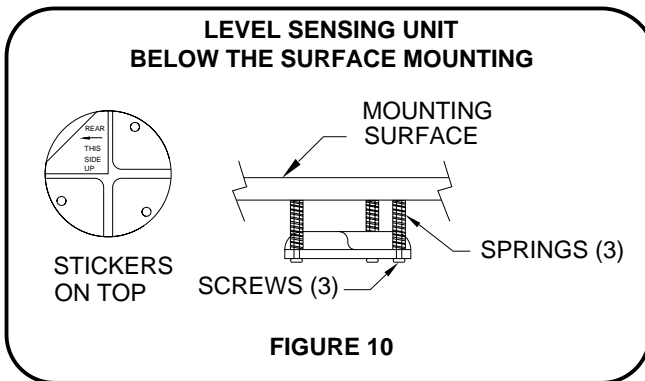

**9. FLUIDS:** Use Mercon, Multipurpose or Dexron automatic transmission fluid. DO NOT USE brake fluid or hydraulic jack fluid. Use of these fluids can damage seals. The hydraulic tank should be filled to within 1" from the top.

### Air Dump - Optional

The air dump feature is used only on coaches with full air bag suspension, not on coaches with spring suspensions and air booster bags.

Most coaches have three height control valves; one for the right rear air bag, one for the left rear air bag, and one for the front two air bags, OR one for the two rear bags, one for left front air bag, and one for the right front air bag.

An air dump solenoid valve must be teed into the air line between each height control valve and the air bag it controls. (See the Air Line Connection Diagram).

On the 200 Series, the air dump signal is on the yellow wires coming from the control panel. There is one connection at the front of the vehicle and one at the rear. A Tee adaptor is supplied with the control system. This will connect two dump valves to one harness connection at the front or rear of the vehicle. (Refer to ELECTRICAL CONNECTION DIAGRAM WITH SUSPENSION AIR DUMP.)

---

## PART III

# COMPONENT INSTALLATION

---

### Check list

1. Check all bolts and brackets for tightness.
2. Check that all hoses are securely clamped or tie wrapped.
3. Check that all wires are securely clamped or tie wrapped.
4. Check oil level before operating the system.
5. Check Hydraulic circuit:
  - a. Hoses are connected to corresponding valves and jacks.
  - b. All fittings for tightness.
6. Check Wiring circuits:
  - a. That color coded wires are hooked properly.
  - b. All cables are securely fastened.
  - c. All ground wires are securely fastened to the ground stud.

**PART III**  
**COMPONENT INSTALLATION**  
**FLUSH MOUNT DASH PANEL TEMPLATE**

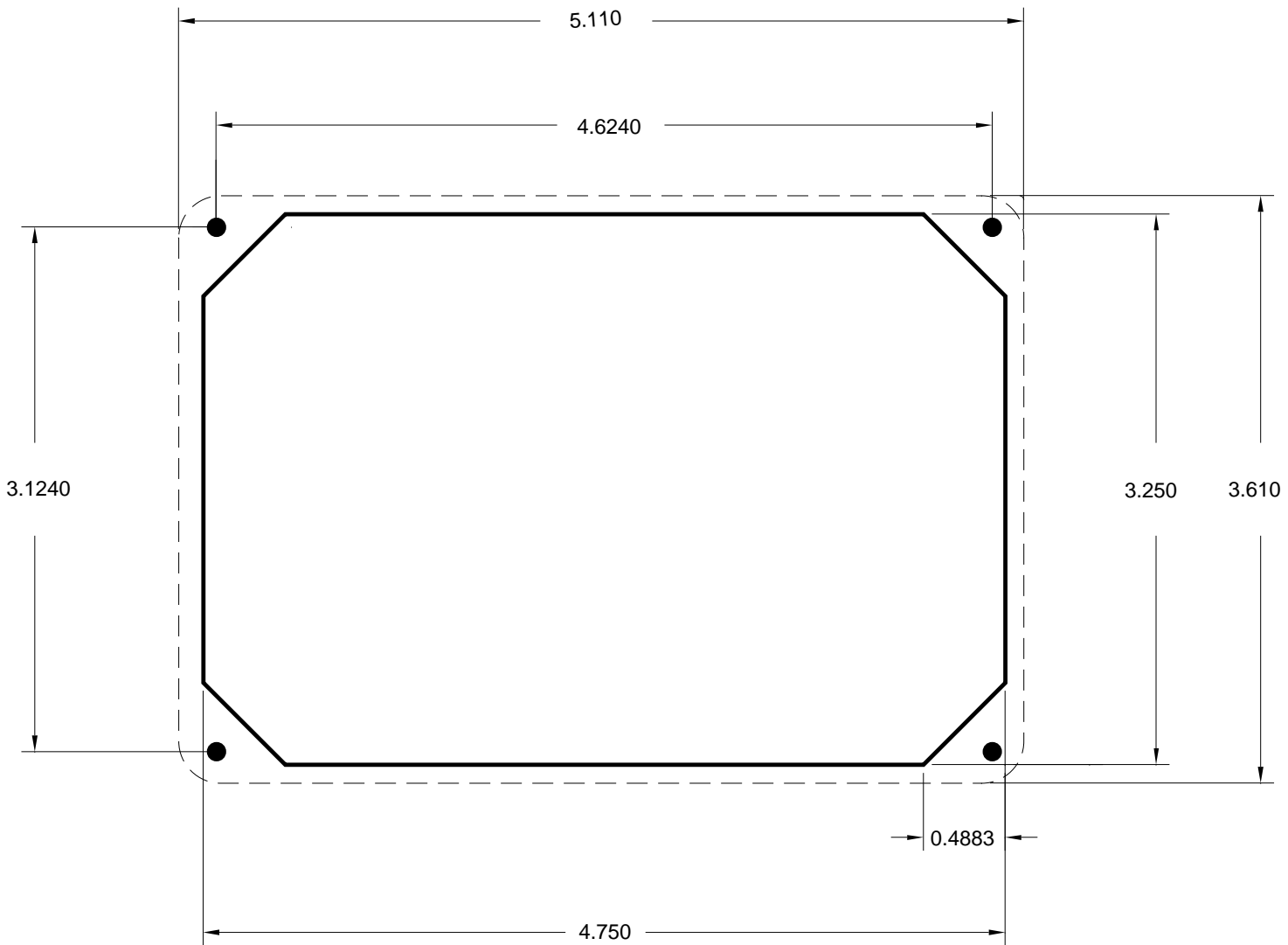

DASH LINE INDICATES OUTER BEZEL  
\* USE ACTUAL BEZEL FOR  
POSITIONING MOUNTING HOLES

# PART IV

## START-UP & ADJUSTMENTS

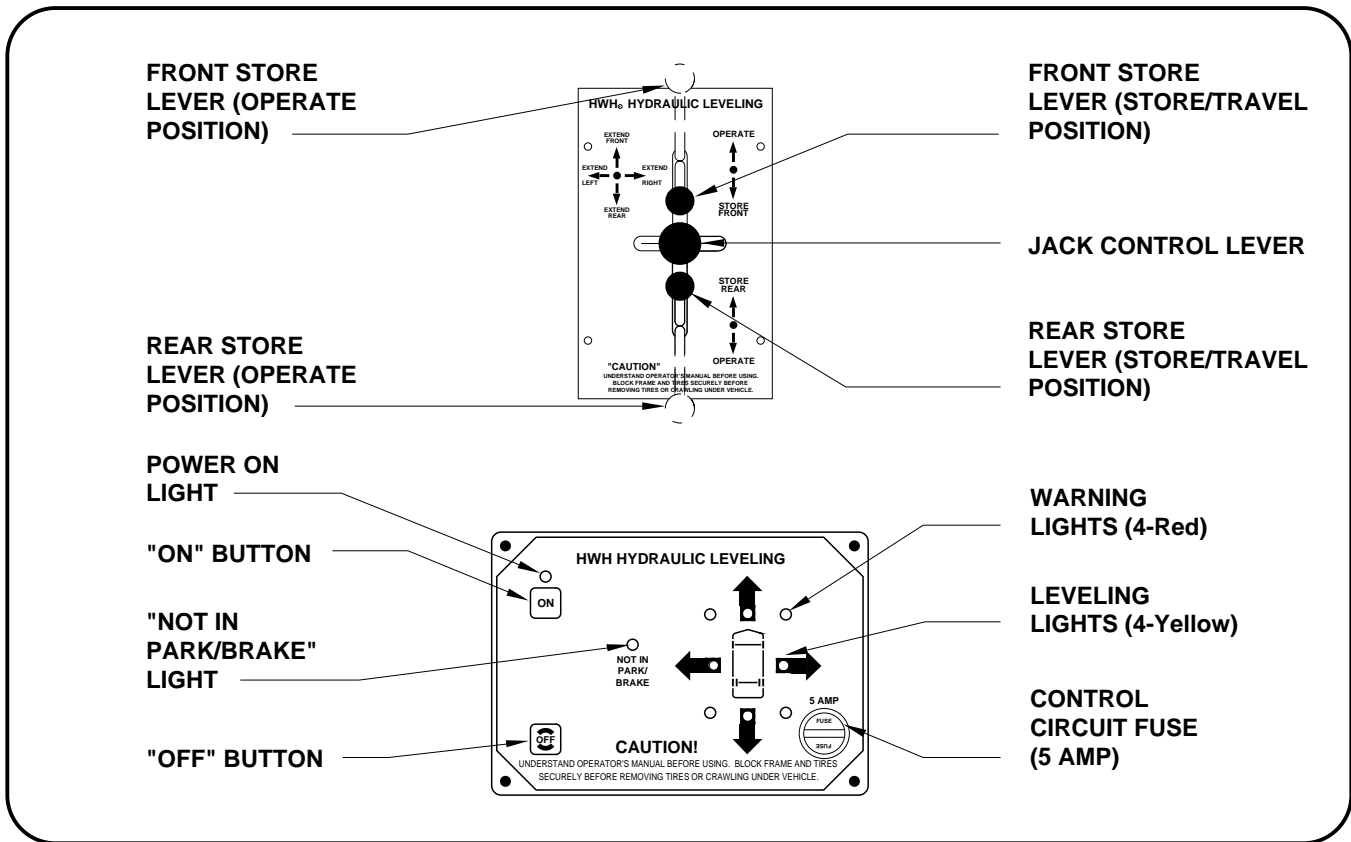

## CONTROL FUNCTIONS

### CONTROLS

**"ON" BUTTON:** This button provides control power to operate the electrical relay on the pump, the LEVELING LIGHTS, the WARNING LIGHTS, and the POWER ON LIGHT. It does not control power to the "JACKS DOWN" LIGHT or the WARNING BUZZER. The ignition switch controls power to these.

**"OFF" BUTTON:** This button turns off control power to the leveling and room extension systems.

**STORE LEVERS:** These two levers are used to retract the jacks into the STORE/TRAVEL POSITION for travel. They must be in "OPERATE" POSITION for leveling.

**JACK CONTROL LEVER:** Jacks are extended in pairs by pushing the jack control lever to one of the "RAISE" positions. This movement of the lever activates the pump and directs hydraulic fluid to the jacks. When the lever is released it will return to the neutral (center) position, turning off the pump and stopping jacks in position.

### INDICATORS

**POWER ON LIGHT:** This light indicates the system is on.

**NOTE:** This light must be on for the room extension to operate.

**"NOT IN PARK/BRAKE" LIGHT:** This light illuminates when the "ON" button is pushed and the parking brake has not been applied. The system will not turn on.

**LEVELING LIGHTS:** A yellow LEVELING LIGHT indicates the side or end of the coach that is low. When the vehicle is level all the LEVELING LIGHTS will be out.

**WARNING LIGHT:** A red WARNING LIGHT indicates the jacks that have extended two inches or more. A WARNING LIGHT illuminates when its corresponding jack is extended at least two inches and the POWER ON LIGHT is illuminated.

**WARNING BUZZER:** A buzzer will sound if a jack is extended two inches or more and the ignition switch is ON.

**"JACKS DOWN" LIGHT:** This light will illuminate when a jack is extended two inches or more and the ignition switch is ON.

## PART IV

# START-UP & ADJUSTMENTS

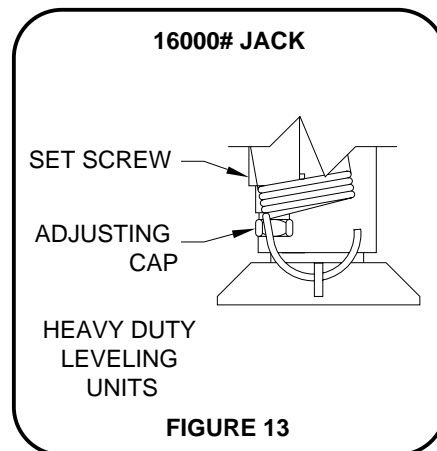
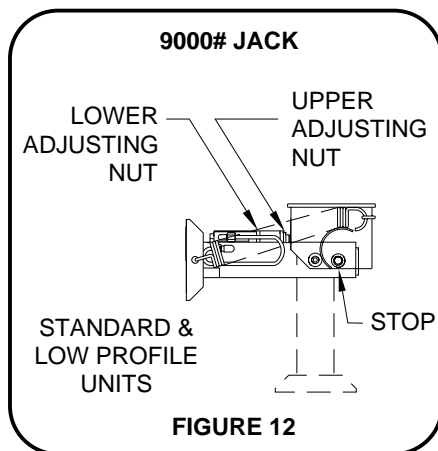
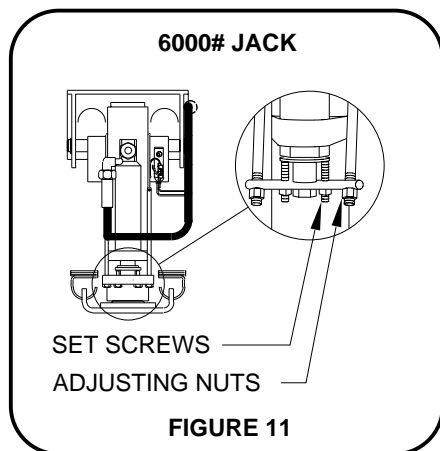

### A. HYDRAULIC START-UP

#### 1. PRIMING PUMP

**JOYSTICK:** To prime the pump turn the ignition key on, then push the "ON" button. Move the STORE levers to the operate position. Push the jack control lever to the front extend position. The lever must be moved to the fullest extent of its travel. This should be done in 3-second intervals until the pump is primed. This can be determined by a lower pitch sound from the pump. Extend the two front jacks until they bump the ground, then RETRACT and refill the tank. Extend the two rear jacks until they bump the ground, then RETRACT and refill the tank. Care should be taken not to run the pump out of fluid as it may damage the pump.

Check the system for hydraulic leaks.

Check that the correct jacks are operating as the control lever is operated.

Refill hydraulic tank to within 1" of the top after all jacks have been operated.

**NOTE:** Do NOT operate system without having the ground wire grounded properly to the chassis.

Consult the respective operator's manuals for specific operating instruction for the system being installed.

#### B. JACK ADJUSTMENTS - KICK DOWN JACKS ONLY

Each jack should be checked to be sure that it is vertical when it swings down. To do this retract all jacks, then extend each jack until it is close to but not touching the ground. Each jack must be adjusted so it can extend in the horizontal position without interfering with any suspension components, tanks, etc.

**1. 6000# JACKS:** Always make the vertical adjustment first. If the vertical adjustment is changed at any time, be sure to check the horizontal adjustment. Vertical adjustment is changed by adjusting the lock (adjusting) nuts on the actuator cable. (FIGURE 11) If the jack stopped short of vertical, tighten the adjusting nuts. If the jack goes past vertical, back the adjusting nuts off. Be sure to adjust each nut the same number of turns.

Horizontal stop is adjusted by turning the set screws located just inside the cable locknuts. The jack can be adjusted down to provide clearance for objects which may interfere with the operation of the jacks. The horizontal stop must be adjusted to provide clearance in case the jack extends in the horizontal position. The jack must be able to fully extend in the horizontal position without interfering with suspension components, tanks, etc.

**2. 9000# JACKS:** If the jack stopped short of being vertical it can be adjusted by loosening the lower actuator nut and tightening the upper actuator nut. (FIGURE 12) If the jack goes past vertical reverse the process.

The horizontal stop can be adjusted up or down in the slot to provide clearance for objects which may interfere with the operation of the jack (FIGURE 12). The stop must be adjusted so that the jack can be fully extended in the horizontal position without interfering with suspension components or tanks, etc.

**3. 16000# JACKS:** If the jack stopped short of being vertical, loosen the set screw and turn the adjusting cap clockwise. If the jack went beyond vertical, loosen the set screw and turn the adjusting cap counterclockwise. After each counterclockwise adjustment, the weight of the coach must be applied to the jack to make the adjustment effective. Do NOT adjust cap more than one turn without cycling the jack (FIGURE 13). The horizontal stop on the heavy-duty jack is adjusted by adding washers under the urethane stop.



---

## PART IV

# START-UP & ADJUSTMENTS

---

### C. INDICATOR LIGHT CHECK

1. Extend one jack at a time and check the corresponding lights to be sure that the wiring is correct and that all lights are functioning properly.
2. The red light indicates that the corresponding jack is in the vertical position, or extended approximately 2" if it is a straight acting jack.
3. The yellow lights indicate that the corresponding corner of of the coach is low.
4. The master warning light and/ or buzzer will come on when any one of the jacks is in the vertical position and the ignition key is in the "ON" position.

### D. LEVELING SENSING UNIT ADJUSTMENT

Level the coach by placing a circular bubble level in the center of the freezer floor or location within the coach that is to be level. With the coach level, adjust the sensing unit until all yellow lights are off. This is done by drawing up the corresponding screw if the sensing unit is mounted above the surface. Bump the sensing unit to see that it has settled down in the level position.

### E. NOT IN PARK/BRAKE CHECK

The "NOT IN PARK/BRAKE" circuit must be tested on the 200 Series Systems.

**CAUTION:** BEFORE RELEASING THE PARK BRAKE, TAKE STEPS TO ASSURE THE VEHICLE WILL NOT ROLL.

With the park brake released, turn the system "ON". The "NOT IN PARK/BRAKE" light should come "ON". This circuit is a safety feature and must operate correctly.

Refer to the vehicle operator's manual and check that the operation of the "BRAKE" light(s) on the dash is correct.

#### **After all adjustments are made:**

1. Run the system several times.
2. Check the oil level.
3. Check the connections and the adjustments one final time.
4. Show the vehicle owner the correct operation of the system.
5. Make sure the owner receives an Operator's Manual kit.

---

# HYDRAULIC LINE CONNECTION DIAGRAM 200/210/225 SERIES BI-AXIS VALVE

---

NOTE: Hose fittings at the pump will come directly out of the pump or if equipped with a room manifold, out of the top of the room manifold.

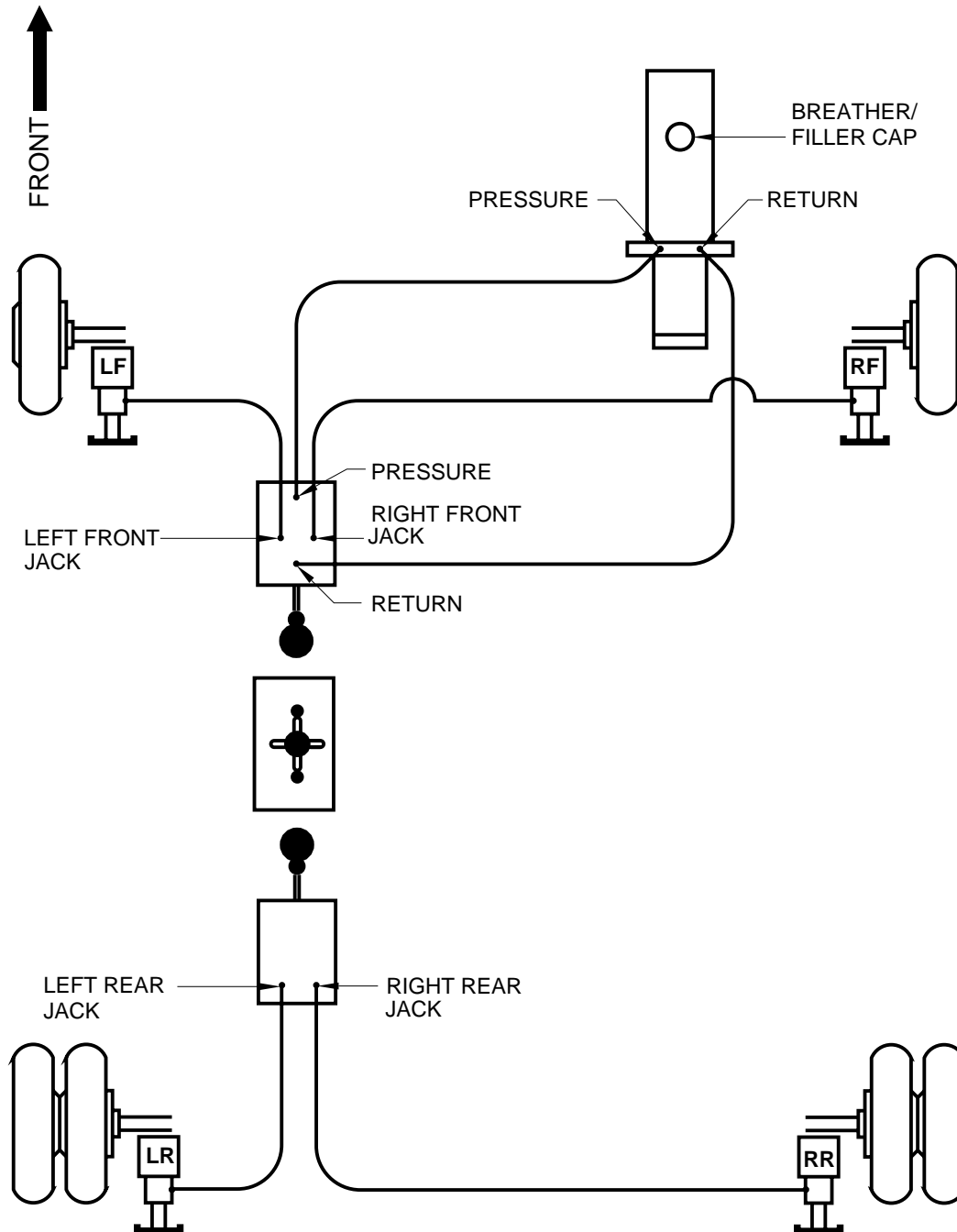

# AIR LINE CONNECTION DIAGRAM

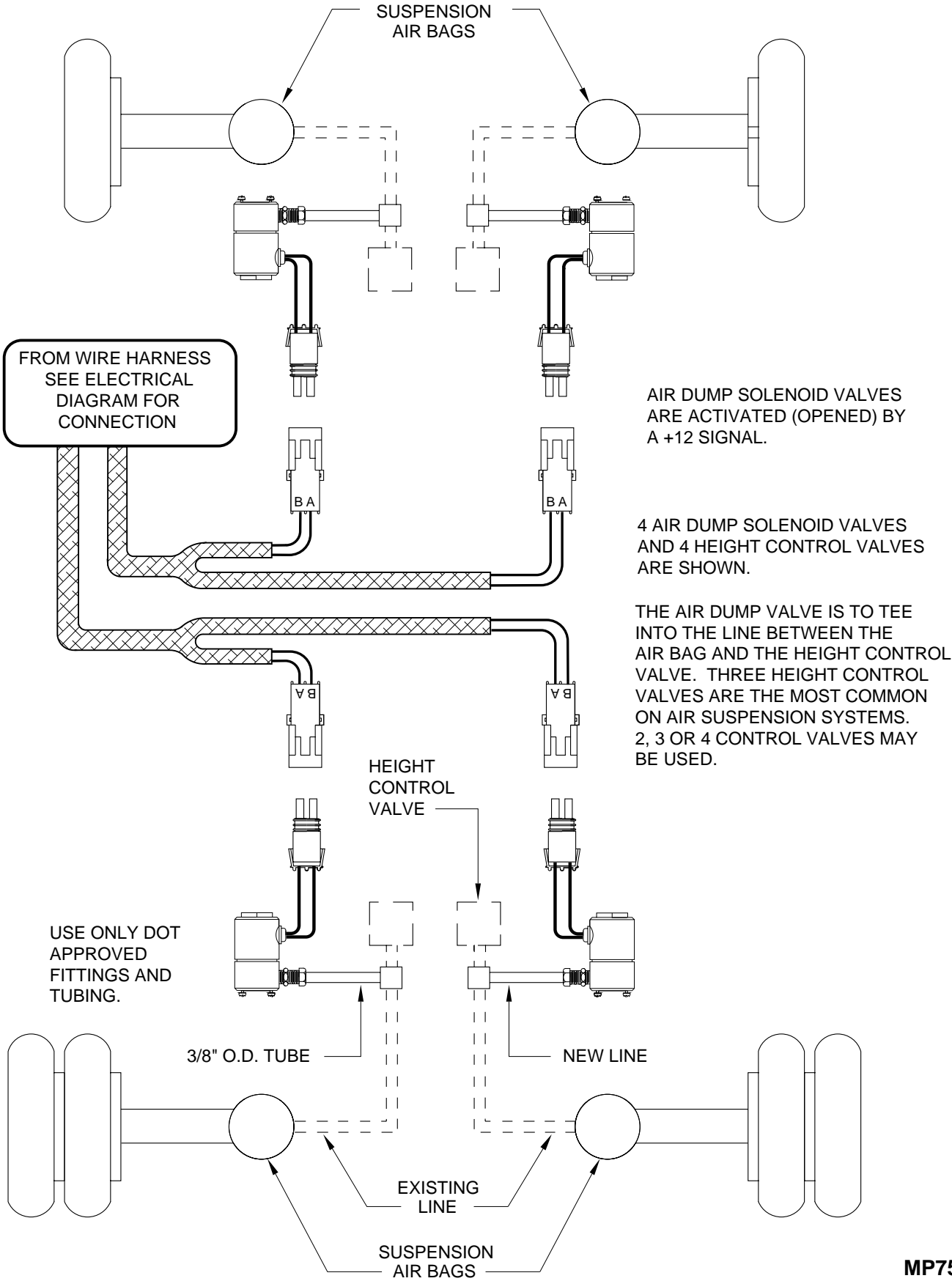

# ELECTRICAL CONNECTION DIAGRAM 200 SERIES LEVELING SYSTEM

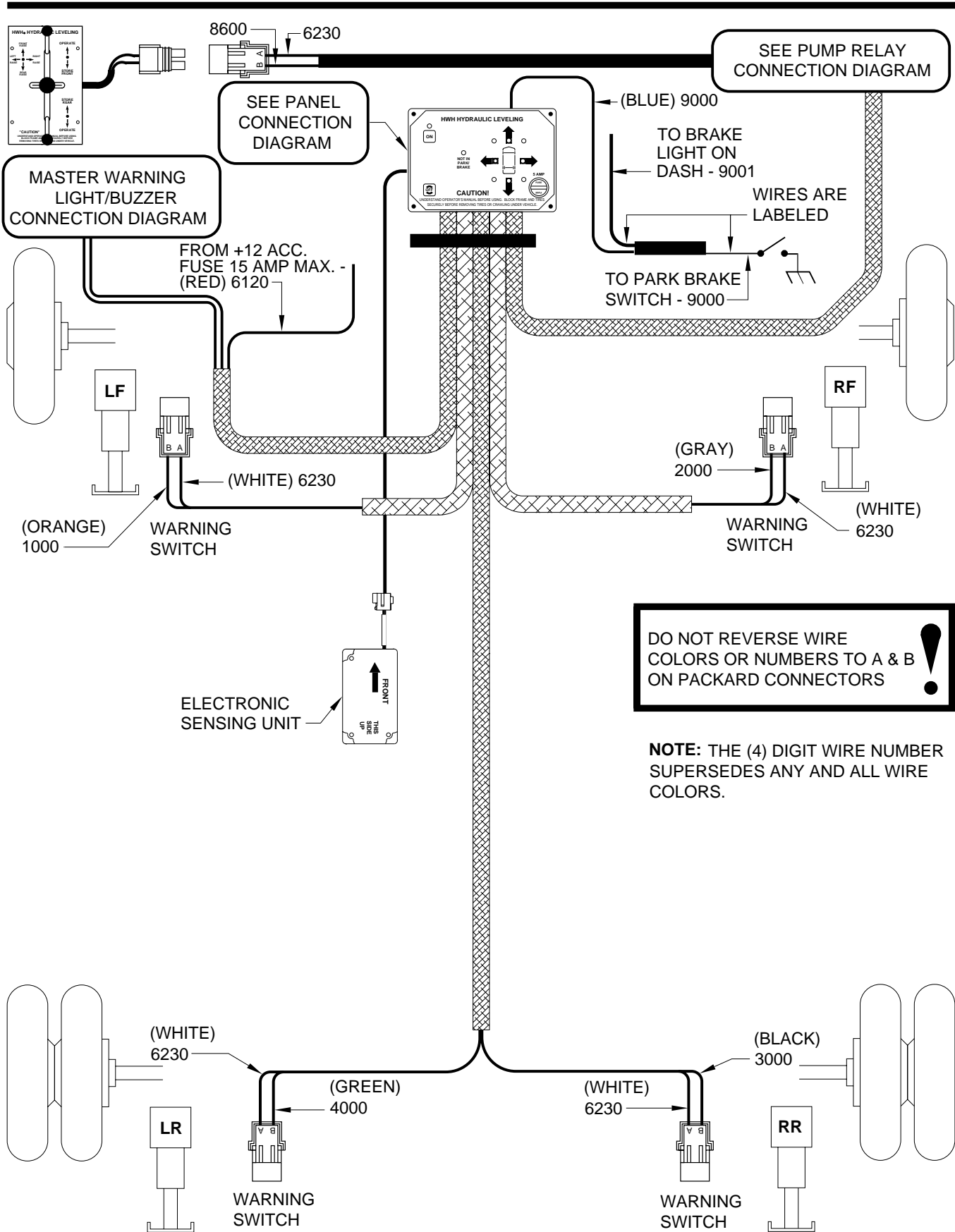

# ELECTRICAL CONNECTION DIAGRAM 200 SERIES LEVELING SYSTEM

## PUMP RELAY CONNECTION DIAGRAM

PUMP MUST BE MOUNTED SOLIDLY TO FRAME. SOME PUMPS HAVE A GROUND CABLE THAT IS TO BE ATTACHED TO THE GROUND STUD.

**NOTE:** THE (4) DIGIT WIRE NUMBER SUPERSEDES ANY AND ALL WIRE COLORS.

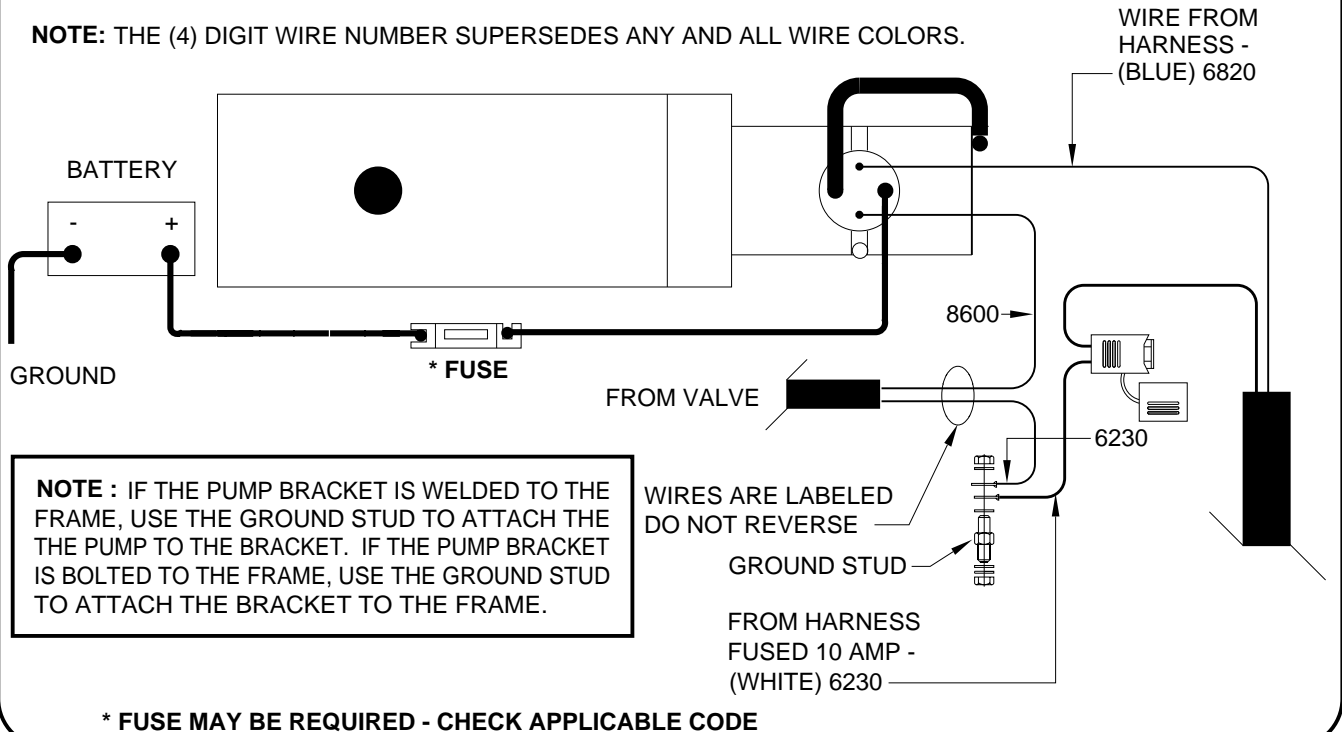

## PANEL CONNECTION DIAGRAM

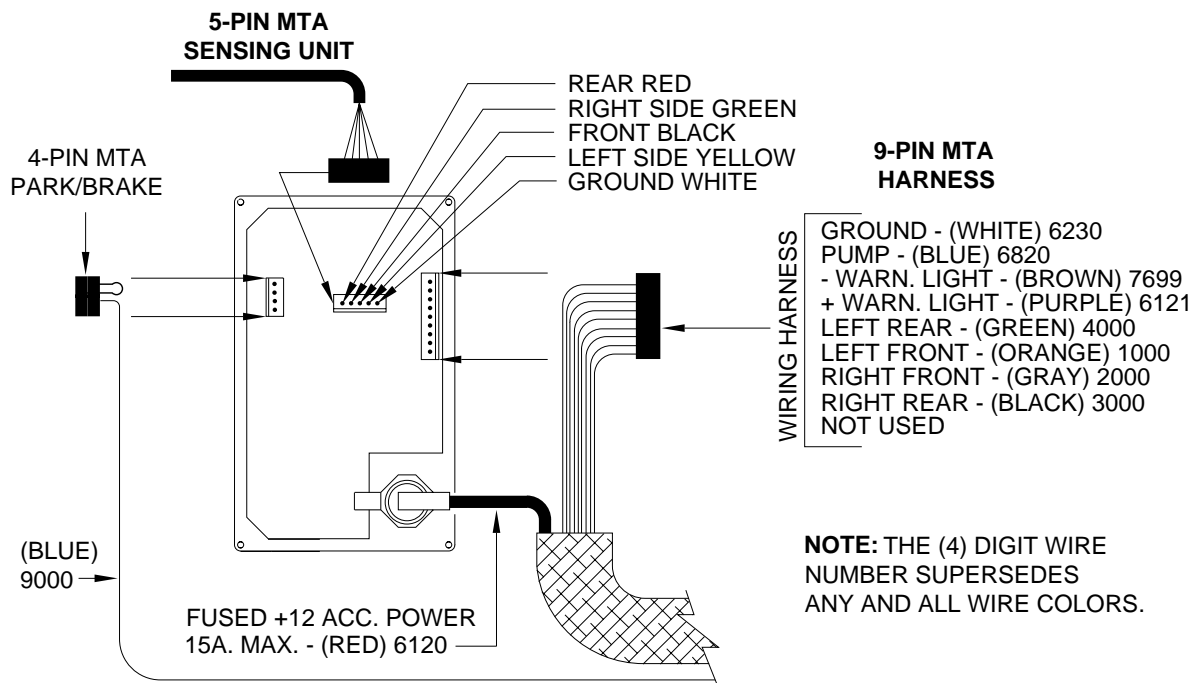

# ELECTRICAL CONNECTION DIAGRAM

## 200 SERIES BI-AXIS VALVE

### WITH SUSPENSION AIR DUMP

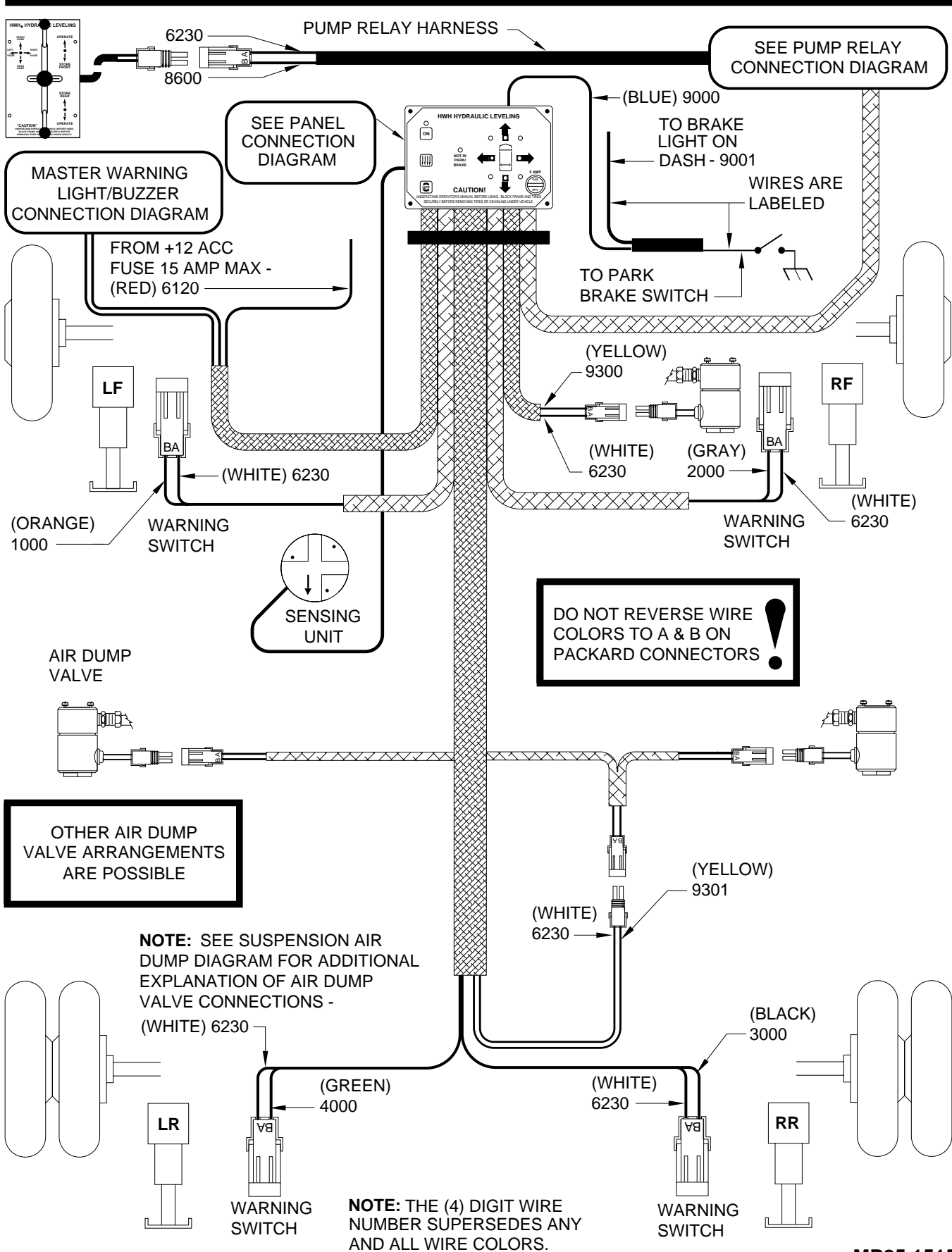

# ELECTRICAL CONNECTION DIAGRAM 200 LEVELING SYSTEM BI-AXIS VALVE WITH SUSPENSION AIR DUMP

## PUMP RELAY CONNECTION DIAGRAM

PUMP MUST BE MOUNTED SOLIDLY TO FRAME. SOME PUMPS HAVE A GROUND CABLE THAT IS TO BE ATTACHED TO THE GROUND STUD.

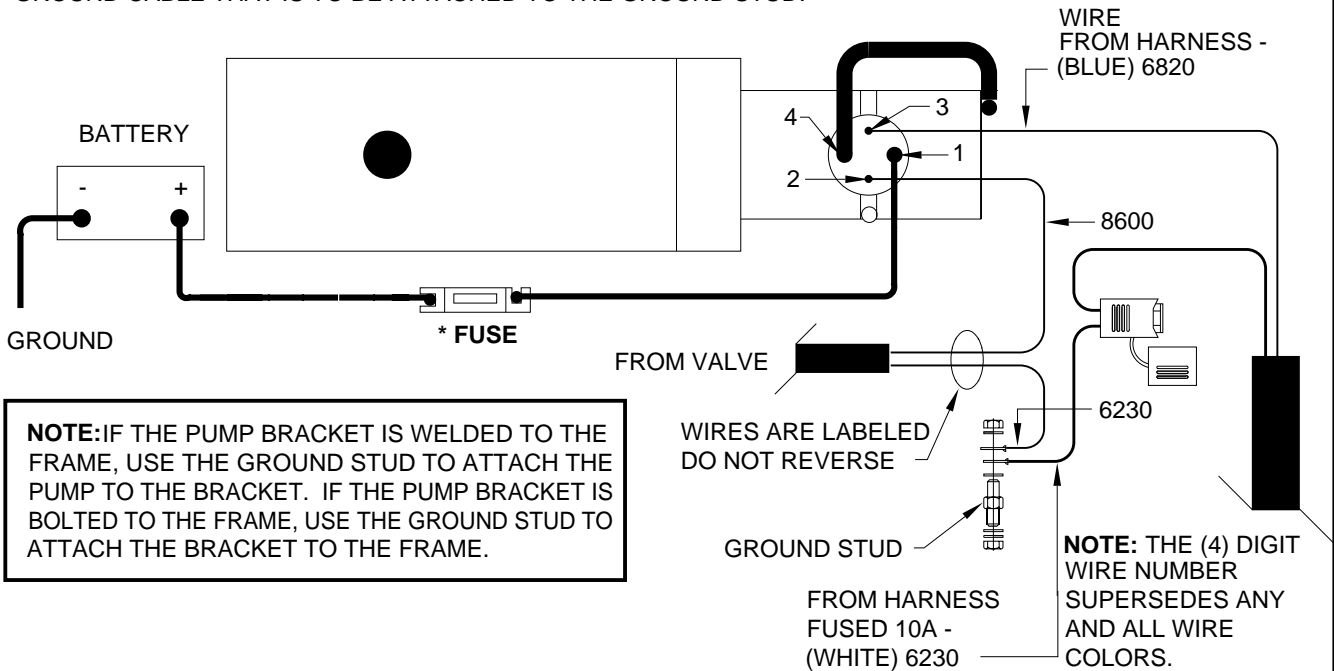

**NOTE:** IF THE PUMP BRACKET IS WELDED TO THE FRAME, USE THE GROUND STUD TO ATTACH THE PUMP TO THE BRACKET. IF THE PUMP BRACKET IS BOLTED TO THE FRAME, USE THE GROUND STUD TO ATTACH THE BRACKET TO THE FRAME.

\* FUSE MAY BE REQUIRED - CHECK APPLICABLE CODE

## PANEL CONNECTION DIAGRAM

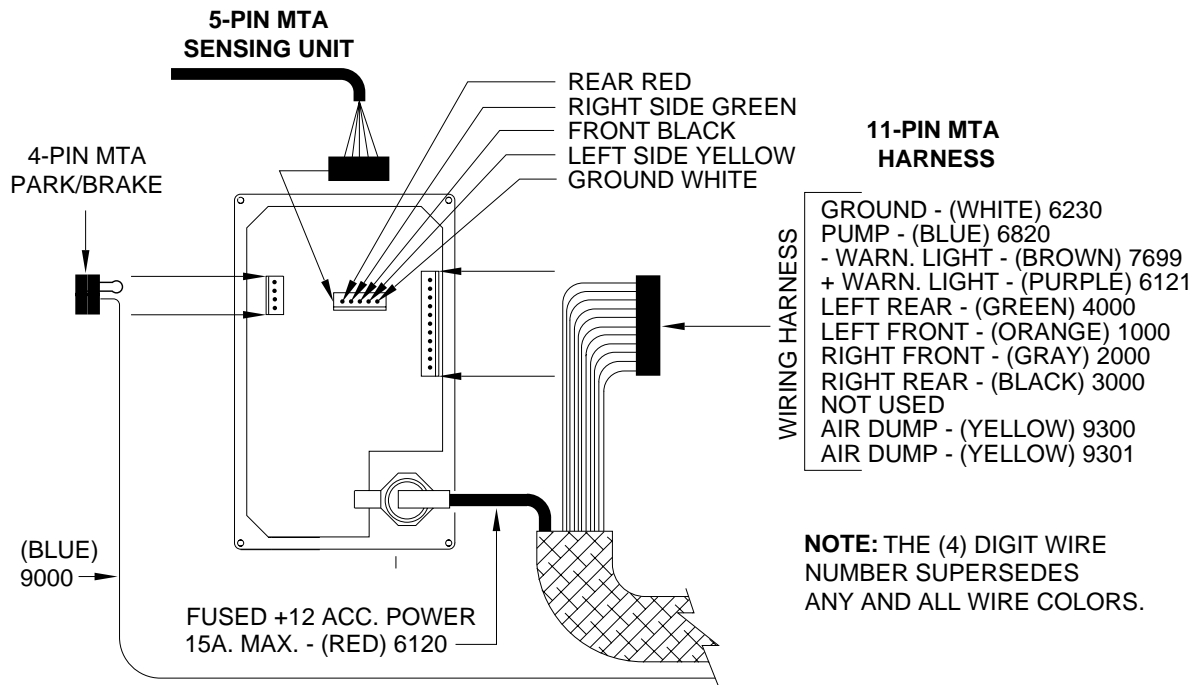

# MASTER LIGHT/BUZZER CONNECTION DIAGRAM MANUAL LEVELING SYSTEMS

A MASTER WARNING INDICATOR SHOULD ALWAYS BE USED. WHEN THE LEVELING SYSTEM HAS STRAIGHT-ACTING JACKS A WARNING BUZZER MUST BE USED.

WHEN ONLY A RED MASTER WARNING LIGHT IS USED THE 12+ POWER FOR THE LIGHT COMES THROUGH THE CONTROL PANEL. (SEE FIGURE 1 BELOW.) WHEN BOTH A RED LIGHT AND WARNING BUZZER ARE USED THE +12 POWER FOR BOTH INDICATORS IS SUPPLIED BY THE IGNITION SWITCH. THE POWER MUST COME FROM THE "ON" SIDE OF THE IGNITION SWITCH, NOT THE "ACC" SIDE. (SEE FIGURE 2 BELOW)

**NOTE:** BY SUPPLYING IGNITION POWER TO THE WARNING BUZZER AND LIGHT, AND "ACC" POWER TO THE CONTROL PANEL, THE SYSTEM MAY BE OPERATED IN ACCESSORY WITHOUT THE BUZZER SOUNDING. THE NEGATIVE SIGNAL FOR THE WARNING INDICATORS MUST ALWAYS COME FROM THE CONTROL PANEL.

**CAUTION:** THE PURPLE WIRE IN THE MASTER WARNING LIGHT HARNESS IS HOT WHENEVER THE IGNITION IS "ON" OR IN "ACC". THE PURPLE WIRE MUST BE REMOVED FROM THE HARNESS WHEN USING DIRECT IGNITION VOLTAGE FOR THE MASTER WARNING INDICATORS.

**NOTE:** THE (4) DIGIT WIRE NUMBER SUPERSEDES ANY AND ALL WIRE COLORS.

