

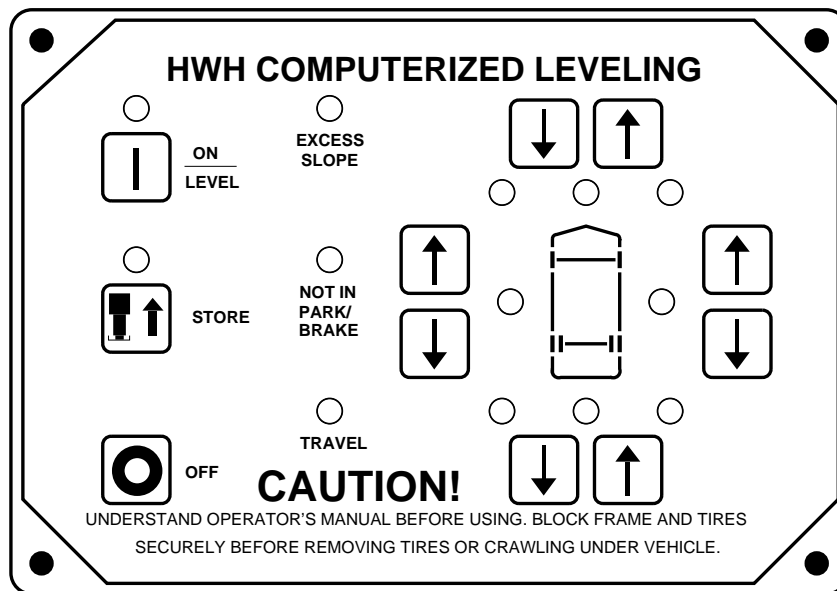

OPERATOR'S MANUAL

HWH COMPUTER-CONTROLLED LEVELING SYSTEM 610 SERIES

FEATURING:
TOUCH PANEL CONTROL
HYDRAULIC LEVELING
STRAIGHT-ACTING JACKS



HWH CORPORATION
(ON I-80, EXIT 267 SOUTH)
2096 MOSCOW ROAD
MOSCOW, IOWA 52760
(800) 321-3494 / (563) 724-3396
INTERNET: <http://www.hwhcorp.com>

AP1125 - US
AP10304 - Europe

ML1125/MP05.5002/CH-S
21MAR01

OPERATOR'S MANUAL

CAUTION !

READ THE ENTIRE OPERATOR'S MANUAL BEFORE OPERATING.

BLOCK FRAME AND TIRES SECURELY BEFORE CRAWLING UNDER VEHICLE. DO NOT USE LEVELING JACKS OR AIR SUSPENSION TO SUPPORT VEHICLE WHILE UNDER VEHICLE OR CHANGING TIRES. VEHICLE MAY DROP AND OR MOVE FORWARD OR BACKWARD WITHOUT WARNING CAUSING INJURY OR DEATH.

KEEP ALL PEOPLE CLEAR OF THE VEHICLE WHILE LEVELING SYSTEM AND ROOM EXTENSIONS ARE BEING OPERATED.

KICK-DOWN JACKS MAY ABRUPTLY SWING UP WHEN THE FOOT OF THE JACK CLEARS THE GROUND OR WHEN THE JACK REACHES FULL EXTENSION.

NEVER PLACE HANDS OR OTHER PARTS OF THE BODY NEAR HYDRAULIC LEAKS. OIL MAY PENETRATE THE SKIN CAUSING INJURY OR DEATH.

WEAR SAFETY GLASSES WHEN INSPECTING OR SERVICING THE SYSTEM TO PROTECT EYES FROM DIRT, METAL CHIPS, OIL LEAKS, ETC. FOLLOW ALL OTHER APPLICABLE SHOP SAFETY PRACTICES.

IF THE VEHICLE IS EQUIPPED WITH KICK-DOWN STYLE JACKS, DO NOT OVER EXTEND THE REAR JACKS. IF THE WEIGHT OF THE VEHICLE IS REMOVED FROM ONE OR BOTH REAR WHEELS, THE VEHICLE MAY ROLL FORWARD OR BACKWARD OFF OF THE JACKS.

NOTE: KEEP THE CONTROL VALVE LEVERS IN THE STORE POSITION WHEN JACKS ARE NOT IN USE.

IMPORTANT: IF VEHICLE IS EQUIPPED WITH A ROOM EXTENSION, READ ROOM EXTENSION SECTION BEFORE OPERATING LEVELING SYSTEM.

HOW TO OBTAIN WARRANTY SERVICE

THIS IS NOT TO BE INTERPRETED AS A STATEMENT OF WARRANTY

HWH CORPORATION strives to maintain the highest level of customer satisfaction. Therefore, if you discover a defect or problem, please do the following:

FIRST: Notify the dealership where you purchased the vehicle or had the leveling system installed. Dealership management people are in the best position to resolve the problem quickly. If the dealer has difficulty solving the problem, he should immediately contact the Customer Service Department, at HWH CORPORATION.

SECOND: If your dealer cannot or will not solve the problem, notify the Customer Service Department:
HWH CORPORATION 2096 Moscow Rd. Moscow IA. 52760
(563) 724-3396 OR (800) 321-3494. Give your name and address, coach manufacturer and model year, date the coach was purchased, or the date of system installation,

description of the problem, and where you can be reached during business hours (8:00 a.m. till 5:00 p.m. c.s.t.). HWH CORPORATION personnel will contact you to determine whether or not your claim is valid. If it is, HWH CORPORATION will authorize repair or replacement of the defective part, either by appointment at the factory or by the authorization of an independent service facility, to be determined by HWH CORPORATION. All warranty repairs must be performed by an independent service facility authorized by HWH CORPORATION, or at the HWH CORPORATION factory, unless prior written approval has been obtained from proper HWH CORPORATION personnel.

CONTROL IDENTIFICATION

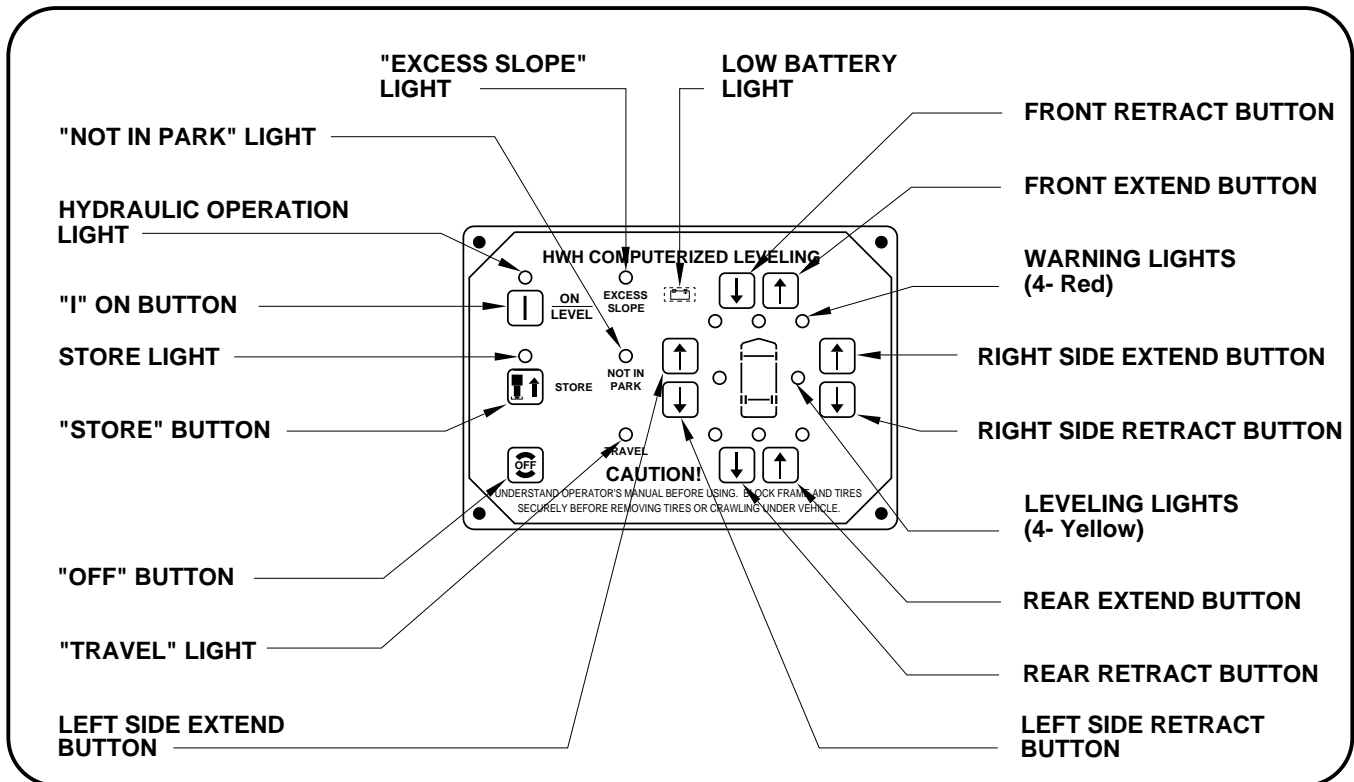

CONTROL FUNCTIONS

CONTROLS

"OFF" BUTTON: Push the "OFF" button to stop hydraulic operation.

"I" BUTTON: This is the on button and automatic operation button. The on indicator light is above the "I" button.

"STORE" BUTTON: The store indicator light is above the "STORE" button. This button is used to automatically retract the jacks.

UP AND DOWN ARROWS: These buttons are for manually controlling the jacks. They will operate the jacks in pairs, right side, left side, front and rear. Pushing UP arrows will cause the jacks to extend and raise the vehicle. The DOWN arrows will cause the jacks to retract.

INDICATOR LIGHTS

LEVELING LIGHTS: The four yellow indicating lights are level sensing indicators. When a yellow light is on, it indicates that its side, end or corner of the vehicle is low. No more than two lights should be on at the same time.

JACK STORAGE LIGHT: This light will flash when the system is in the store mode.

JACK DOWN WARNING LIGHTS: The four red lights surrounding the yellow level indicators are jack WARNING lights. They are functional only when the ignition is in the "ON" or "ACC" position, the system is on, and the jacks are extended 2 or more inches.

"EXCESS SLOPE" LIGHT: This indicator will light when the leveling system cannot level the vehicle.

"NOT IN PARK/BRAKE" LIGHT: This indicator will light when the panel is on and the hand/auto brake is not set.

"TRAVEL" LIGHT: This indicator light will be on when the ignition is on, when the jacks are retracted and there are no red WARNING lights on.

LOW BATTERY LIGHT: This indicator will be on when the controller senses low voltage.

MASTER "JACKS DOWN" WARNING LIGHT: This is a light mounted in the dash separate from the touch panel. It will be on when any one or more jacks are extended and the ignition is "ON".

BUZZER: This is a jacks down warning. It will sound if the master "JACKS DOWN" warning light is on.

OPERATING PROCEDURES

GENERAL INSTRUCTIONS

Maintain adequate clearance in all directions for vehicle, room extensions, awnings, doors, steps, etc. Vehicle may move in any direction due to jacks extending or retracting, settling of the jacks or the vehicle, equipment malfunction, ect.

If parking on soft ground or asphalt paving, wood blocks or pads must be placed under the jacks.

Press the "OFF" button and turn the ignition switch "OFF" at any time to stop the operation of the system.

Any time a hydraulic leveling process is interrupted, retract the jacks according to the JACK RETRACTION Section and then restart the leveling process.

If the "LOW BATTERY" indicator is on, the system should be checked. Battery voltage should be checked, also all connections should be checked.

If the hand / auto brake is not set when the "I" button is pressed, the "NOT IN PARK/BRAKE" light will come on and the system will not operate.

PREPARATION FOR TRAVEL

Before traveling, the red jack warning lights must be off and the "TRAVEL" light must be on. If lights are not correct for travel, retract jack as described in the JACK RETRACTION Section.

If the jacks are retracted but a red "WARNING" light is lit or the green "TRAVEL" light is not lit, the system needs to be serviced.

The room extension should be fully retracted before traveling.

CAUTION: DO NOT MOVE THE VEHICLE WHILE THE LEVELING JACKS ARE STILL IN CONTACT WITH THE GROUND OR IN THE EXTEND POSITION. THIS VEHICLE IS EQUIPPED WITH STRAIGHT-ACTING JACKS. MOVING THE VEHICLE

WITH THE LEVELING JACKS EXTENDED CAN CAUSE SEVERE DAMAGE TO THE JACKS AND OR THE VEHICLE AND CREATE A DRIVING HAZARD. DO NOT RELY SOLELY UPON WARNING LIGHTS. IT IS THE OPERATOR'S RESPONSIBILITY TO CHECK THAT ALL JACKS ARE FULLY RETRACTED INTO THE STORE/TRAVEL POSITION.

If the jacks cannot be retracted according to the JACK RETRACTION Section, retract the jacks according to the MANUAL JACK RETRACTION Section. The system should then be checked.

ROOM EXTENSION PROCEDURES

IMPORTANT: If the vehicle is equipped with a room extension read this section carefully.

If the vehicle is equipped with kick-down jacks, the wheels MUST be blocked securely. Do NOT operate any room extension until the leveling and stabilizing procedure is complete. Do NOT retract the leveling system until all room extensions are retracted. NEVER operate the leveling system when any room extensions are extended.

Refer to the vehicle owners manual for proper operation of room extensions.

IMPORTANT: Do not use a room extension support when the vehicle is supported by the leveling system.

OPERATING PROCEDURES

AUTOMATIC HYDRAULIC LEVELING

1. Place transmission in the recommended position for parking vehicle and set parking brake. Turn the ignition to the "ACCESSORY" position.
2. Press the "I" button to enter the hydraulic operation mode. The "I" indicator light will glow steady.
3. At this time, the operator may want to check the jacks and place pads under the jacks if the ground will not support the vehicle.
4. Press the "I" button a second time. The "I" indicator light will start to flash. The system will automatically extend the jacks to level the vehicle and then extend any remaining jacks until they contact the ground, lifting the vehicle slightly. After the system has finished leveling and stabilizing, it will automatically shut off.

EXCESS SLOPE SITUATION: In the event the jacks are unable to level the coach, the "EXCESS SLOPE" indicator light will come on. The pump will shut off. One or two yellow leveling indicator lights will remain on. The "HYD" indicator light will continue to blink for 2 minutes, then the system will shut off. The system will NOT stabilize the vehicle if the "EXCESS SLOPE" light comes on. Store the jacks according to the JACK RETRACTION Section. Move the vehicle to a more level position or level the vehicle as close as possible according to the MANUAL HYDRAULIC OPERATION Section.

5. Turn the ignition switch to the "OFF" position.

JACK RETRACTION

CAUTION: THE OPERATOR MUST BE SURE THAT THERE ARE NO OBJECTS UNDER THE VEHICLE AND THAT ALL PEOPLE ARE CLEAR OF THE VEHICLE.

NOTE: Any room extensions should be fully retracted before retracting the jacks.

1. Turn the ignition switch to "ON", "ACC", or start the engine. Press the "I" button one time. The "I" indicator light will glow steady.
2. Press the "STORE" button. The store indicator light will flash. As each jack retracts, its red WARNING light will go out. The vehicle can be moved as soon as the red WARNING lights are out and the green "TRAVEL" light is on, providing the jacks are in the STORE/TRAVEL position.

IMPORTANT: DO NOT interrupt power to the leveling system while the "STORE" indicator light is blinking. DO NOT push the "OFF" button or turn the ignition key. The system must be allowed to completely finish the store mode. If the engine was started before putting the system in the store mode, the vehicle may be moved when the jacks are in the STORE/TRAVEL position. This will not interrupt the store procedure.

CAUTION: DO NOT MOVE THE VEHICLE WHILE THE LEVELING JACKS ARE STILL IN CONTACT WITH THE GROUND OR IN THE EXTEND POSITION. THIS VEHICLE IS EQUIPPED WITH STRAIGHT-ACTING JACKS. MOVING THE VEHICLE WITH THE LEVELING JACKS EXTENDED CAN CAUSE SEVERE DAMAGE TO THE JACKS AND OR THE VEHICLE AND CREATE A DRIVING HAZARD. DO NOT RELY SOLELY UPON WARNING LIGHTS. IT IS THE OPERATOR'S RESPONSIBILITY TO CHECK THAT ALL JACKS ARE FULLY RETRACTED INTO THE STORE/TRAVEL POSITION.

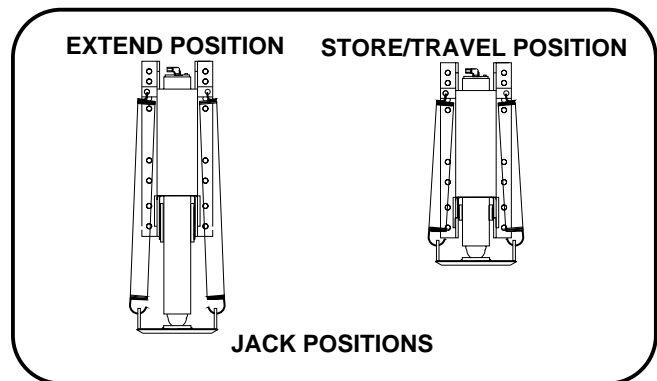

3. The system will automatically shut down six minutes after the four individual red "WARNING" lights are out. If any one red "WARNING" light does not go out, the system will continue to store for thirty (30) minutes, then shut down regardless of the "WARNING" lights condition.

4. If jacks cannot be retracted by the above procedure see MANUAL JACK RETRACTION Section.

NOTE: If the vehicle is parked or stored with the jacks extended for an extended period of time and the jacks fail to retract completely, extend the jacks back down to the ground then retract the jacks again.

OPERATING PROCEDURES

MANUAL HYDRAULIC OPERATION

1. Place transmission in the recommended position for parking the vehicle, and set the parking brake. Turn the ignition to the "ACCESSORY" position.

2. Press the "I" button. The indicator light will glow steady.

3. Place pads under the jack feet if the ground will not support the vehicle on the jacks.

4. The vehicle may be leveled using the manual EXTEND buttons on the right half of the panel. If a yellow LEVEL SENSING light is on, that side or end of the vehicle is low. Jacks will extend

(or retract) in pairs to raise (or lower) a side or end of the vehicle. Any jack not used for leveling can be extended to the ground. This provides additional stability against wind and activity in the vehicle.

IMPORTANT: Do not continue to push an EXTEND button for more than ten (10) seconds after that pair of jacks are fully extended.

5. When leveling is completed, push the "OFF" button on the touch panel and turn the ignition switch to the "OFF" position.

MANUAL JACK RETRACTION

NOTE: Use the valve release "T" handles for retracting only if the "STORE" button on the control panel will not retract the jacks for travel.

CAUTION: KEEP AWAY FROM THE WHEELS, DO NOT CRAWL UNDER THE VEHICLE, KEEP A SAFE DISTANCE IN FRONT AND REAR OF VEHICLE. THE VEHICLE MAY DROP AND/OR MOVE FORWARD OR BACKWARD WITHOUT WARNING AS THE VALVE RELEASE IS OPERATED.

1. Locate the 4 valve release "T" handles on the solenoid valves. The solenoid valves are located on the pump/valve assembly. See the "Hydraulic Line Connection Diagram Leveling System."

2. Allow clearance for vehicle to lower.

3. Retract the rear jacks by opening the two outer valves. Slowly turn the "T" handles counter clockwise. The handles may turn

easily at first but as an internal spring is compressed, turning may become more difficult. The valves need only to be opened enough to retract the jack.

4. Retract the front jacks by opening the two center valves as described in Step 3.

5. Check that all four jacks are now retracted.

6. Close the valves by turning the release handles clockwise.

Once the internal spring tension has been released, the handles will turn free for several turns. Once the "T" handles are snug, DO NOT tighten the handles past this point as internal damage may occur to the solenoid.

7. The system should now be repaired before using again.

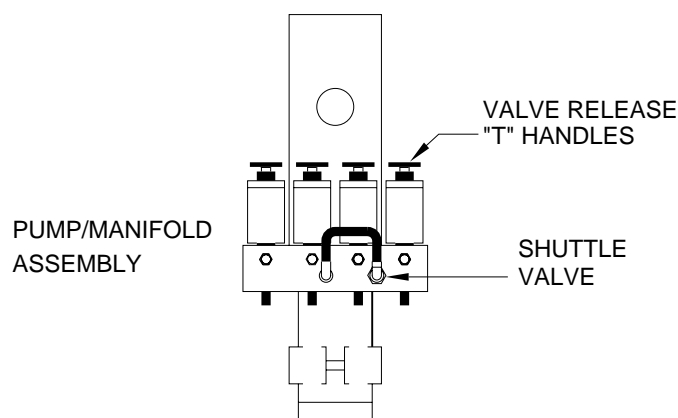

ROOM EXTENSION MANIFOLD NOT SHOWN

MP35.5023
24NOV99

MAINTENANCE

OIL LEVEL

It is important that the four leveling jacks and any room extensions are fully retracted before checking the hydraulic oil level. To check the oil supply, remove the breather cap from the top of the hydraulic oil reservoir. The oil level should be approximately one inch below the top of the reservoir when adequately filled.

FLUID: HWH Specialty Hydraulic Oil is recommended. In an emergency Dexron automatic transmission fluid can be used.
NOTE: Dexron automatic transmission fluid contains red dye and can cause staining should a leak occur. **DO NOT USE** brake fluid or hydraulic jack fluid. Use of these can damage seals.

ELECTRICAL SYSTEM

The batteries should be in good condition and fully charged. Weak batteries can cause erratic operation. Battery cable terminals and battery posts and connections should be kept clean.

All electrical connections, especially ground connections, should be clean, tight, free from corrosion and protected from weathering.

UNUSUAL CONDITIONS

If driving conditions are unusually muddy, the jacks may become caked or clogged with mud. This condition may hamper the proper operation of the leveling system. This problem may be prevented or remedied by cleaning off each leveling jack if they become excessively muddy.

Do not move the vehicle while the leveling jacks are still in contact with the ground. Retract the jacks according to the "JACK RETRACTION" Section and then visually check to see if the leveling jacks have returned to the STORE/TRAVEL position.

In wet or icy weather leveling jacks may become encrusted with ice. This may cause the leveling system to function improperly. To eliminate this problem, periodically check the leveling jacks and break loose any ice which may be causing improper operation.

NOTE: All major components of the system can be replaced with rebuilt parts or can be sent to HWH CORPORATION to be rebuilt, when the system is out of warranty.

OPERATIONAL CHECK

Review the operator manual and run the system in the automatic and manual mode. Note any abnormal operation.

can cause erratic operation or damage components. Contact your dealer or HWH CORPORATION for assistance.

Check that all lights work according to the INDICATOR LIGHT section. Correct function of the four red WARNING lights is essential to the correct operation of the system.

Review the JACK RETRACTION Section.

Check that the vehicle is level when all the yellow LEVEL indicator lights are out.

Make sure the jacks will fully retract to the store position. Jacks should not interfere with any part of the vehicle when in the store position.

NOTE: The level sensing unit has an accuracy tolerance of + or - 1 inch side to side, and + or - 5.4 inches front to rear on a 36 foot vehicle.

With the jacks extended, check that the jacks can be retracted using the "T" handles on the solenoid valves. Refer to the MANUAL JACK RETRACTION Section.

If the red LOW BATTERY indicator light comes on, the electrical system should be checked. If the light comes on, the operation of the system is not interrupted, but low voltage

MAINTENANCE

LEVEL SENSING UNIT ADJUSTMENT

Level the vehicle by placing a circular bubble level in the center of the freezer floor or location within the vehicle that is to be level. With the vehicle level, adjust the sensing unit until all yellow lights are off. This is done by drawing up the corresponding screw if the sensing unit is mounted below the surface as shown or backing out the corresponding screw if the sensing unit is mounted above the surface. Bump the sensing unit to see that it is settled tight against all three screw heads and still indicates that the unit is level.

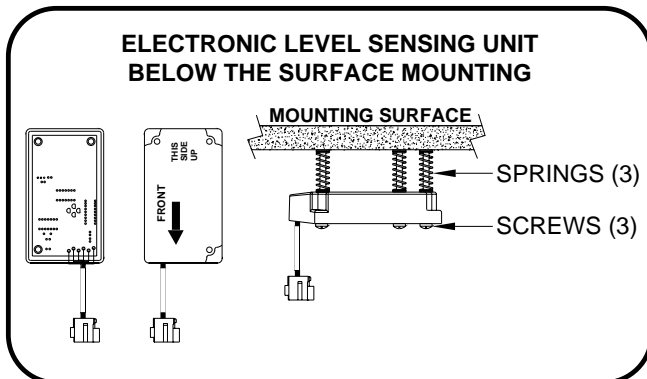
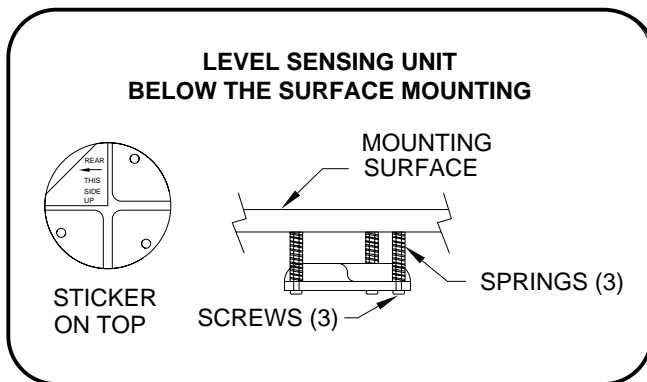

"NOT IN PARK/BRAKE" CHECK

CAUTION: WHEN MAKING THIS CHECK, BLOCK THE VEHICLES WHEELS SECURELY SO THE VEHICLE CANNOT ROLL FORWARD OR BACKWARD.

Set the park brake. Switch the ignition to "ACCESSORY" or "ON" position. Press the "I" button one time. Release the parking brake and confirm that the "NOT IN PARK/BRAKE" indicator light comes on. Reset the parking brake. The "NOT IN PARK/BRAKE" indicator light should go out. Switch the ignition to "OFF".

NOTE: If any of the previous checks or inspections reveal a problem or if there are other problems or questions, consult a qualified RV repair center, your vehicle or coach manufacturer, or HWH CORPORATION for service or repair.

HYDRAULIC LINE CONNECTION DIAGRAM LEVELING SYSTEM



FRONT

NOTE: BEFORE OPERATING VALVE RELEASE "T" HANDLES, READ AND UNDERSTAND PROCEDURE FOR MANUAL JACK RETRACTION IN OPERATOR'S INSTRUCTIONS.

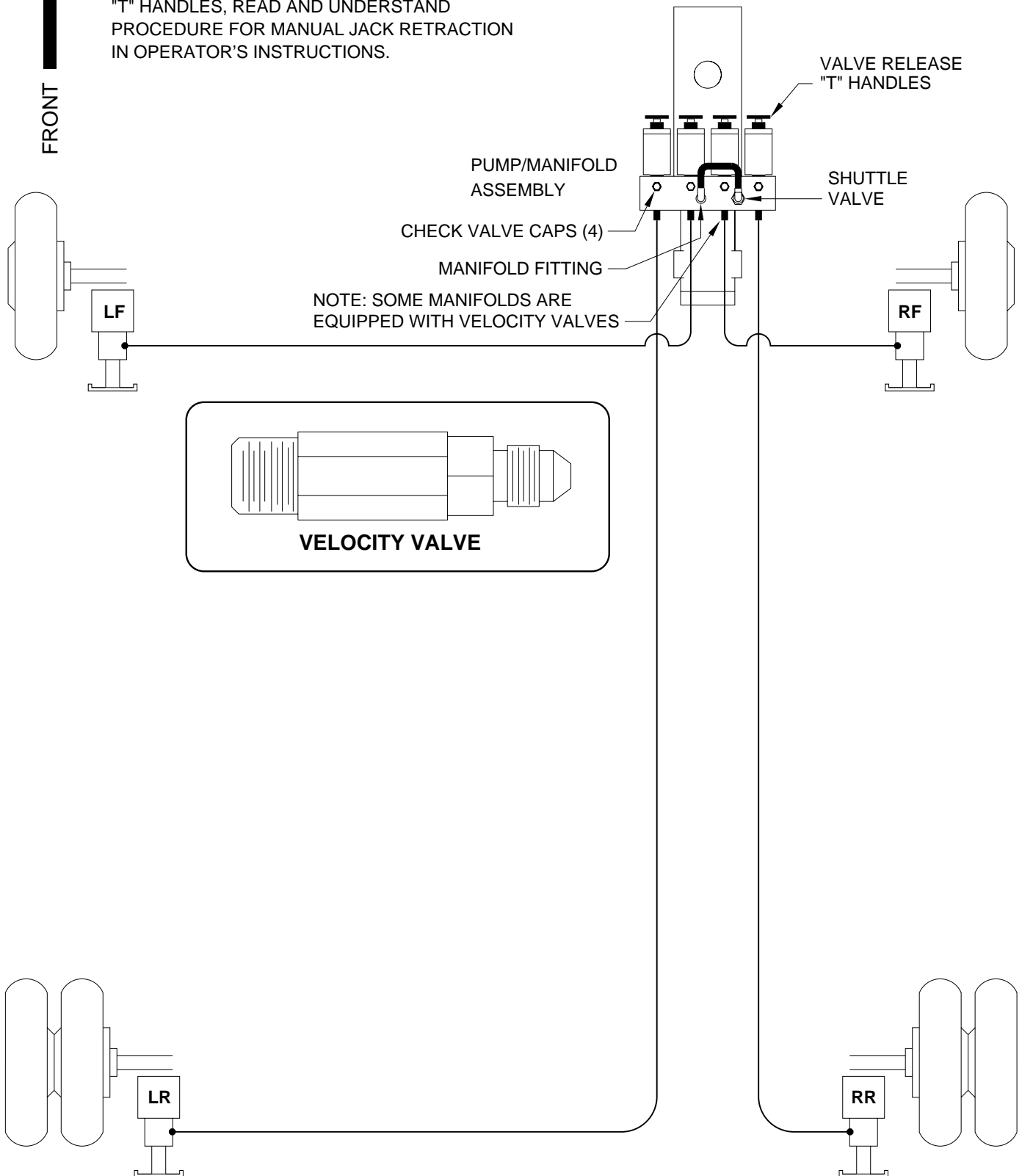

HYDRAULIC SCHEMATIC

BI-AXIS LEVELING WITH STRAIGHT-ACTING JACKS

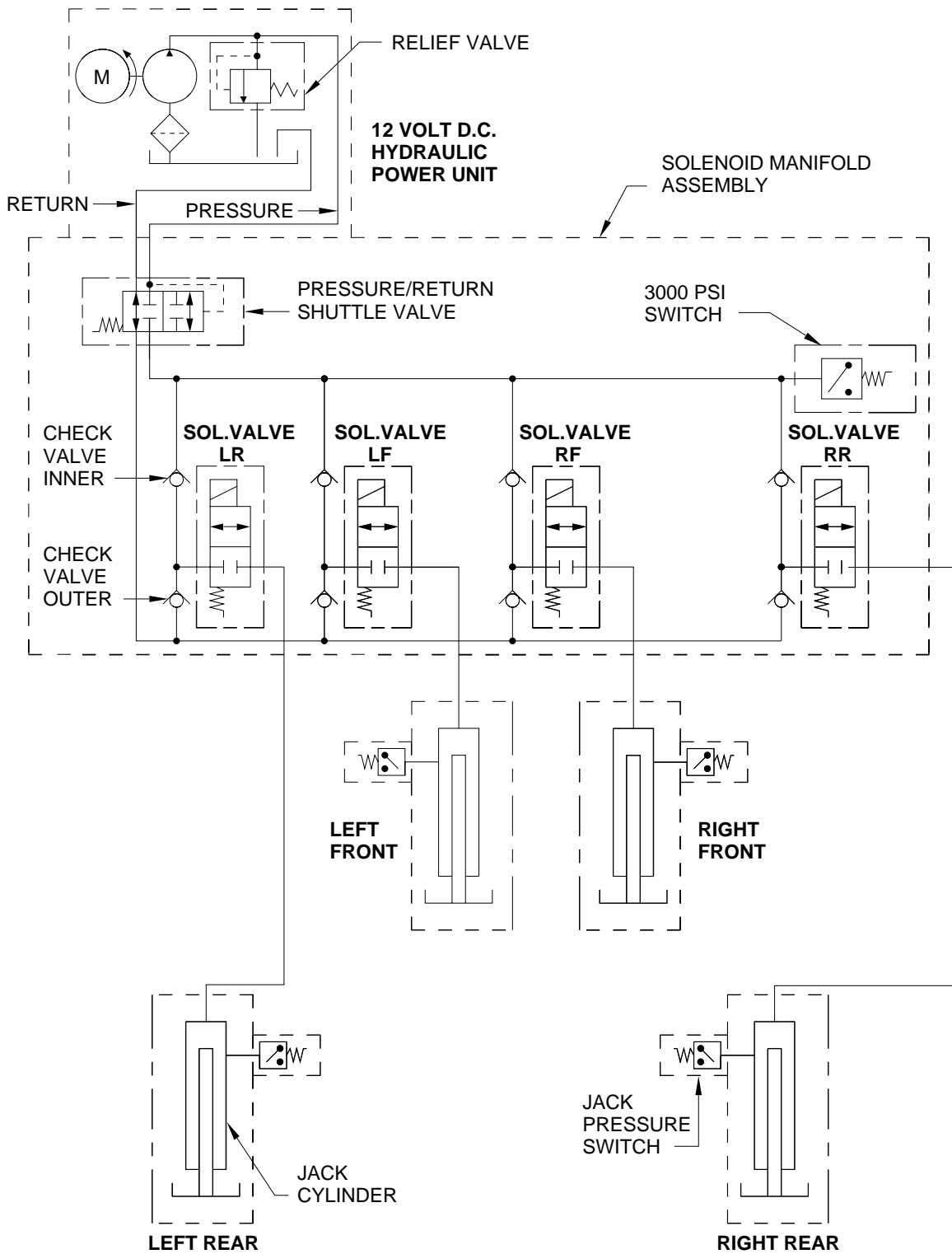

CONNECTION INFORMATION 610 SERIES LEVELING SYSTEM

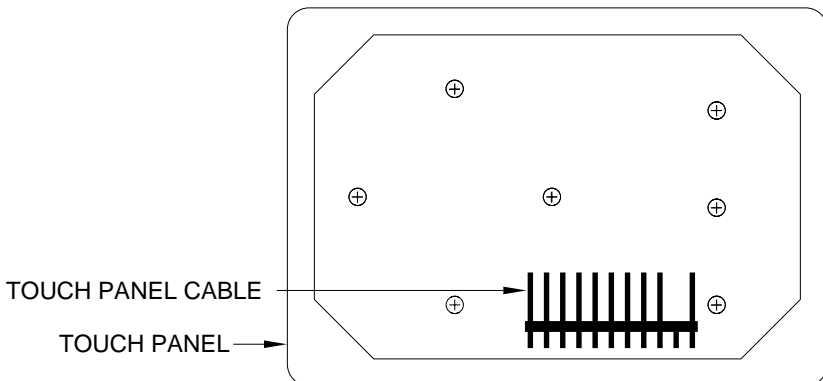
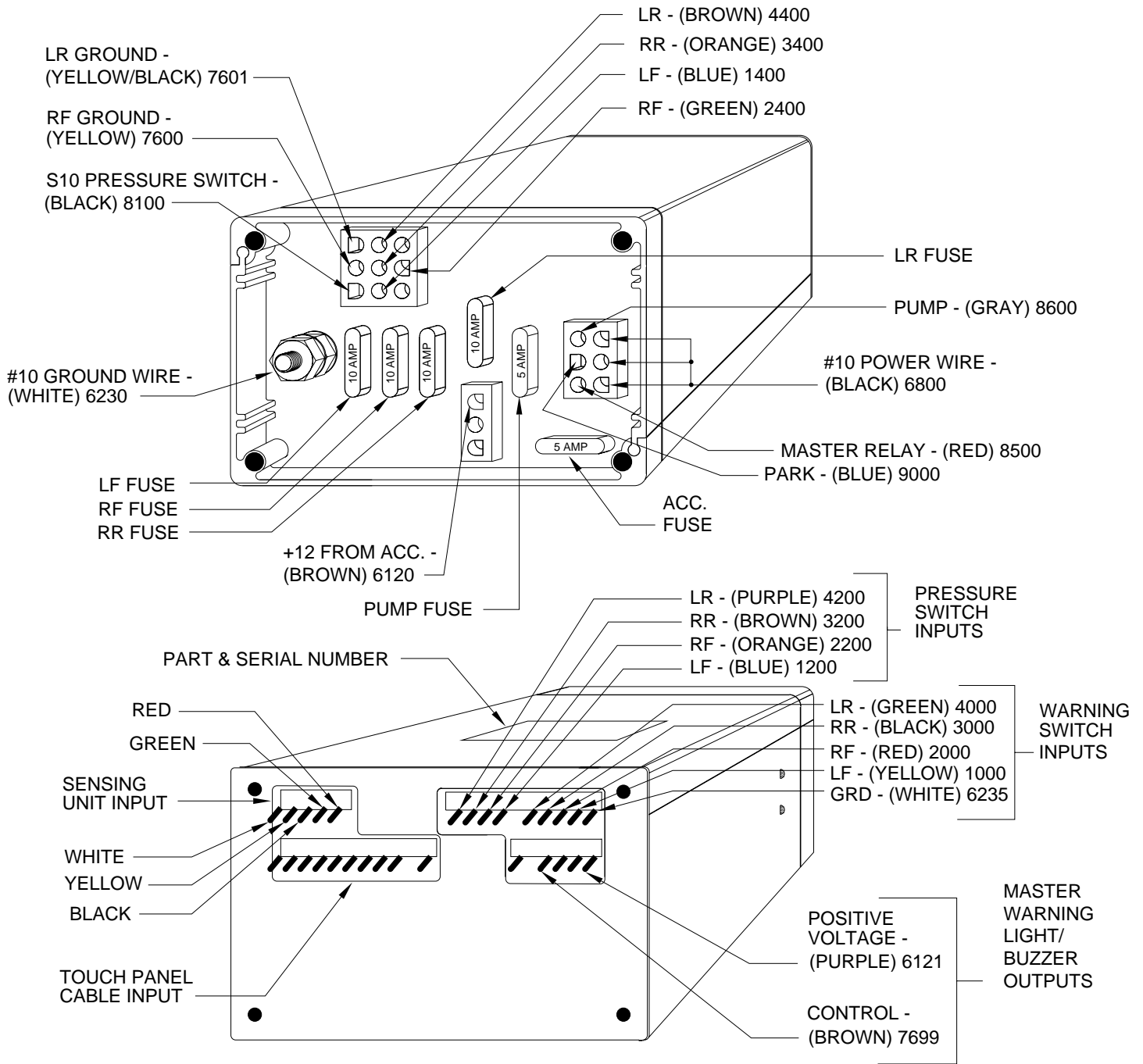

NOTE: THE (4) DIGIT WIRE NUMBER SUPERSEDES ANY AND ALL WIRE COLORS

ELECTRICAL CONNECTION DIAGRAM 610 SERIES LEVELING SYSTEMS

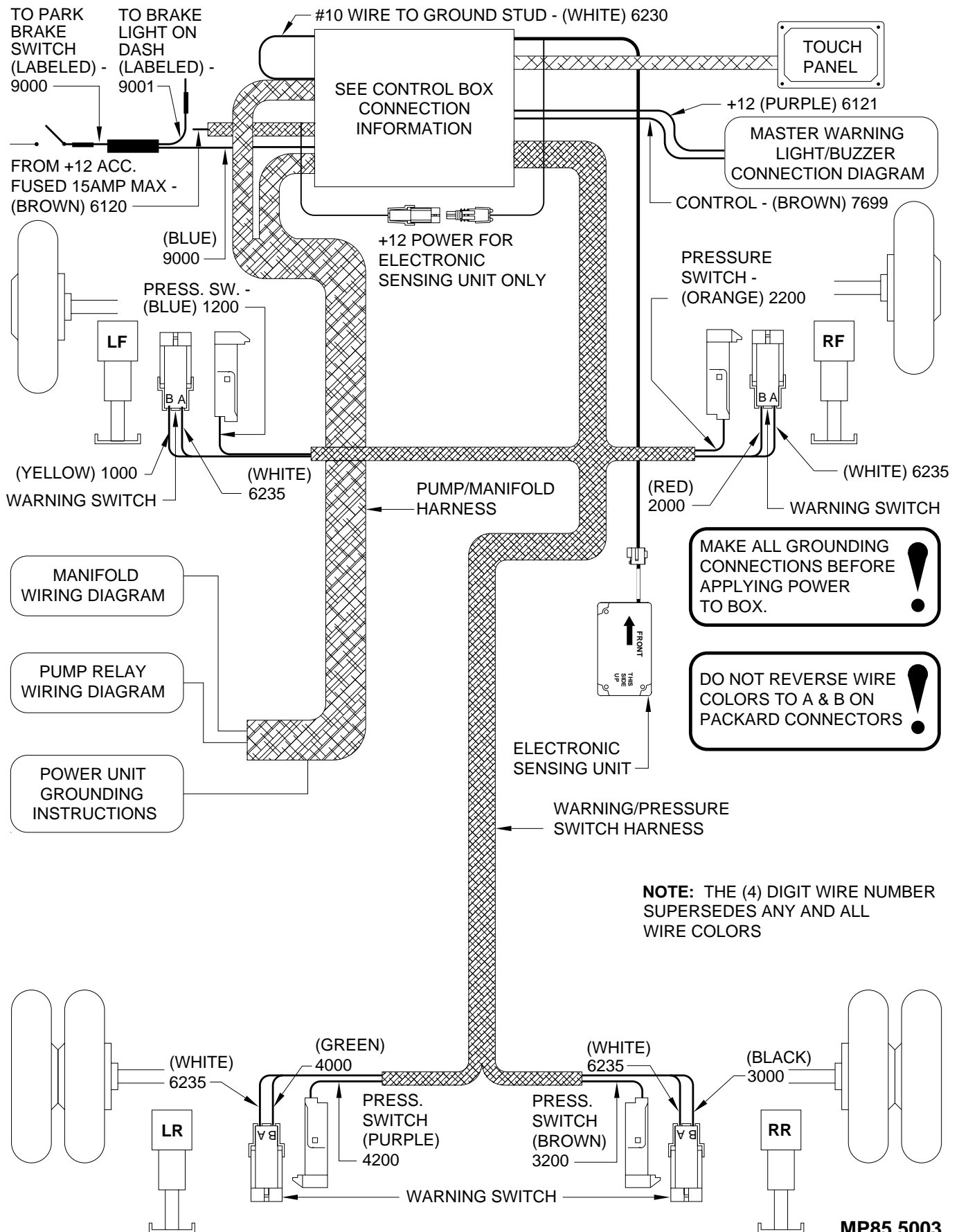

WIRING DIAGRAM MANIFOLD FOR 610 SERIES LEVELING SYSTEMS

NOTE: ROOM EXTENSION MANIFOLD NOT SHOWN.

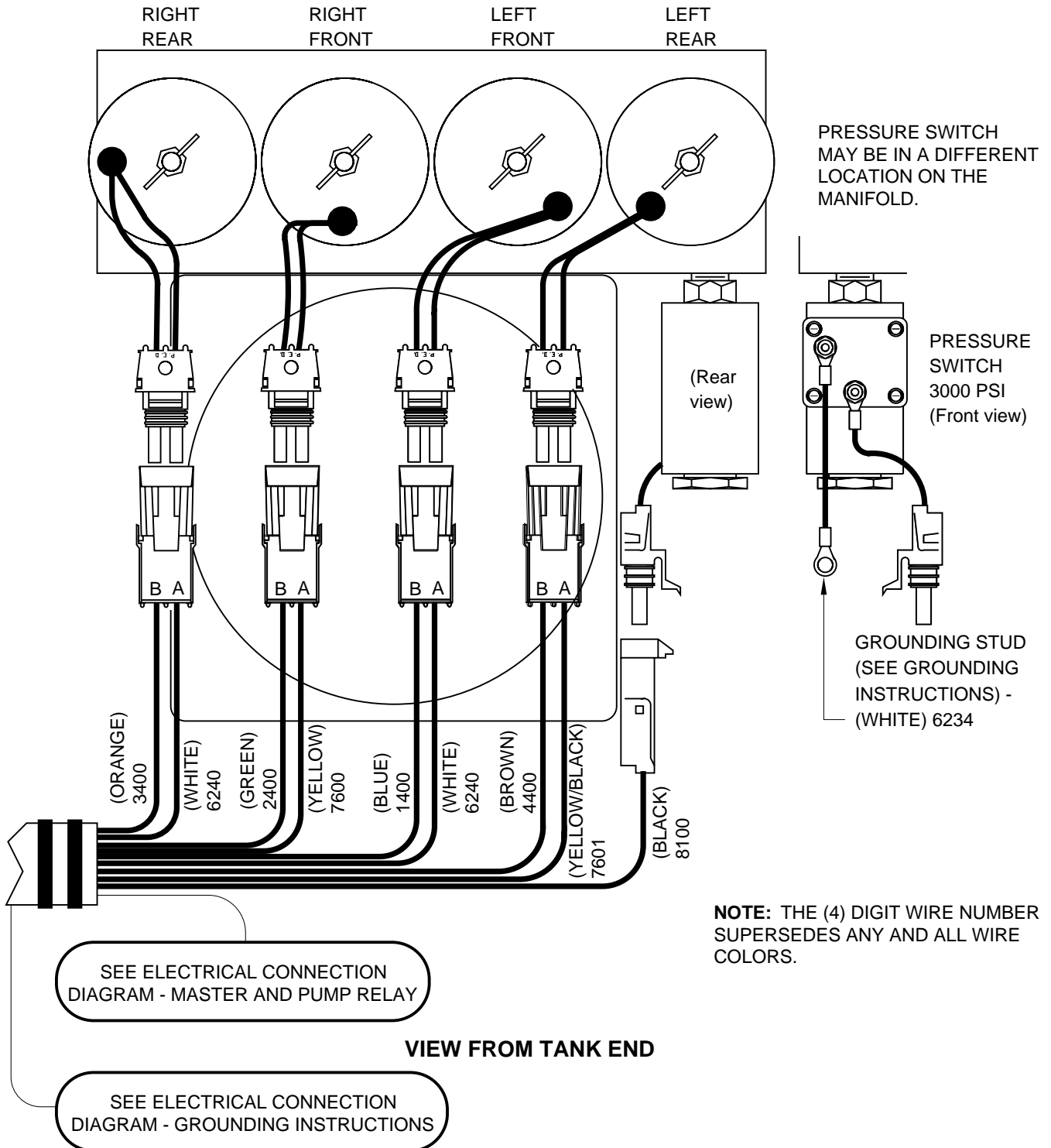

ELECTRICAL CONNECTION DIAGRAM MASTER AND PUMP RELAY FOR 610 SERIES LEVELING SYSTEMS

NOTE: THE (4) DIGIT WIRE NUMBER SUPERSEDES ANY AND ALL WIRE COLORS.

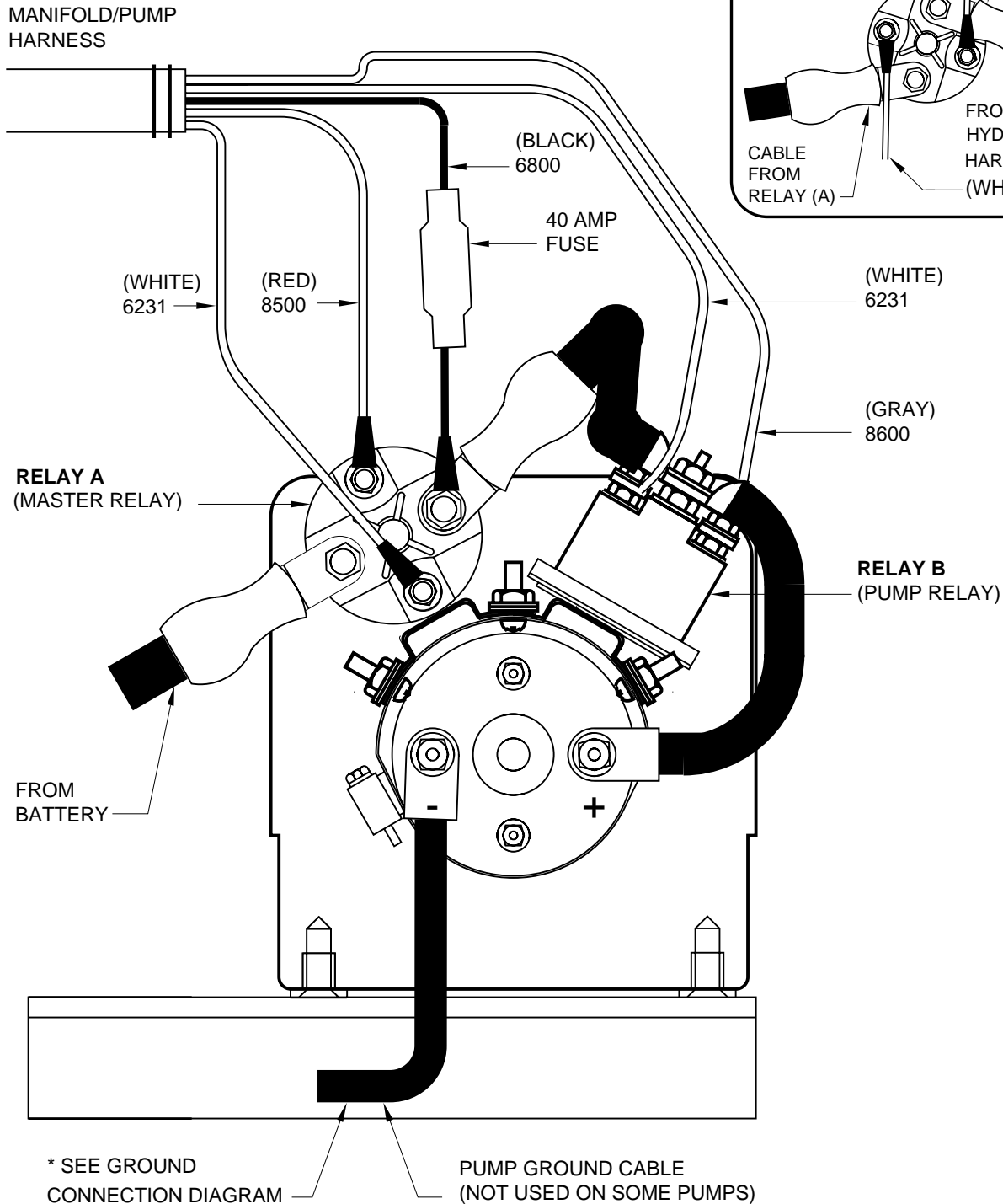
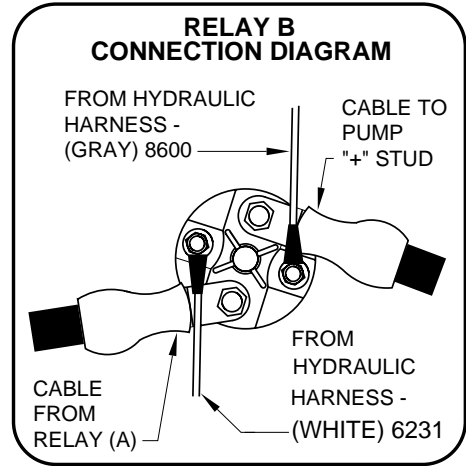

ELECTRICAL CONNECTION DIAGRAM

POWER UNIT/HARNESS GROUNDING INSTRUCTIONS

610 SERIES LEVELING SYSTEMS

WELDED PUMP MOUNT

Use grounding stud and 3/8" internal star lockwashers as shown.

IMPORTANT: STAR LOCKWASHER MUST BE USED BETWEEN GROUNDING SURFACE AND WIRE TERMINALS

NOTE: THE (4) DIGIT WIRE NUMBER SUPERSEDES ANY AND ALL WIRE COLORS.

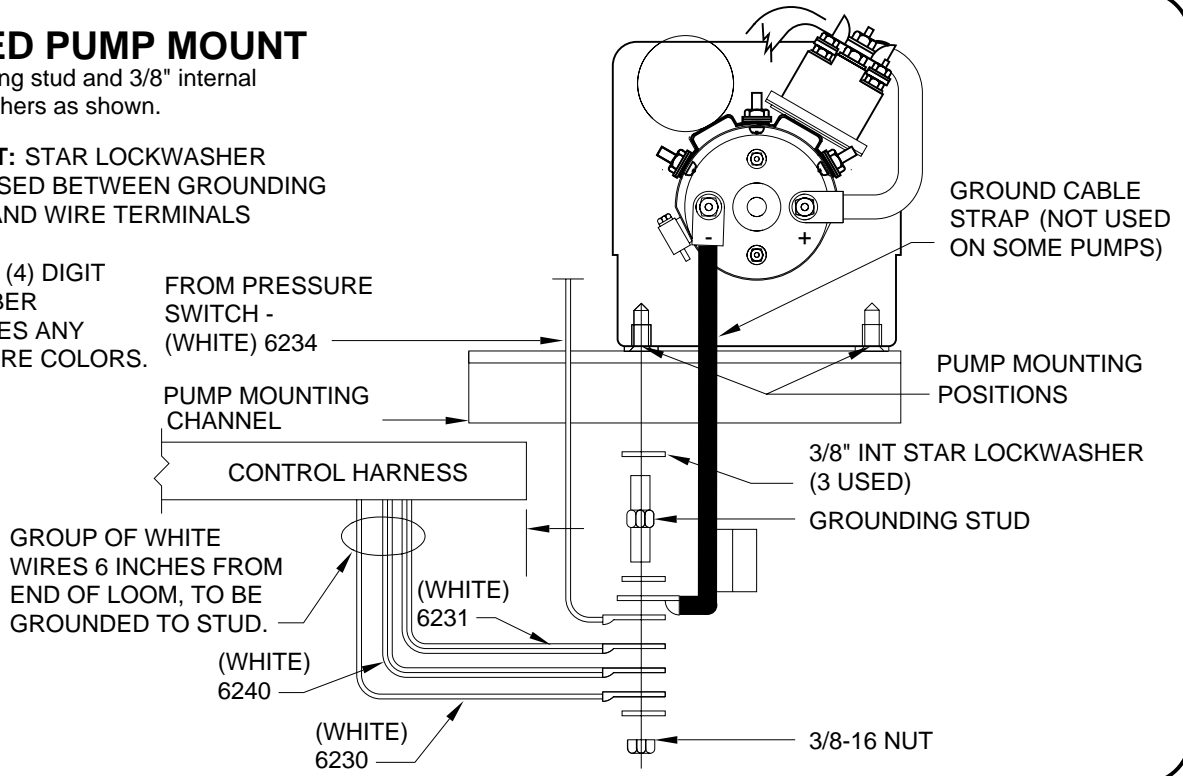

PUMP MOUNTED REMOTE FROM FRAME

Use grounding stud and 3/8" internal star lockwashers as shown.

IMPORTANT: STAR LOCKWASHER MUST BE USED BETWEEN GROUNDING SURFACE AND WIRE TERMINALS

NOTE: THE (4) DIGIT WIRE NUMBER SUPERSEDES ANY AND ALL WIRE COLORS.

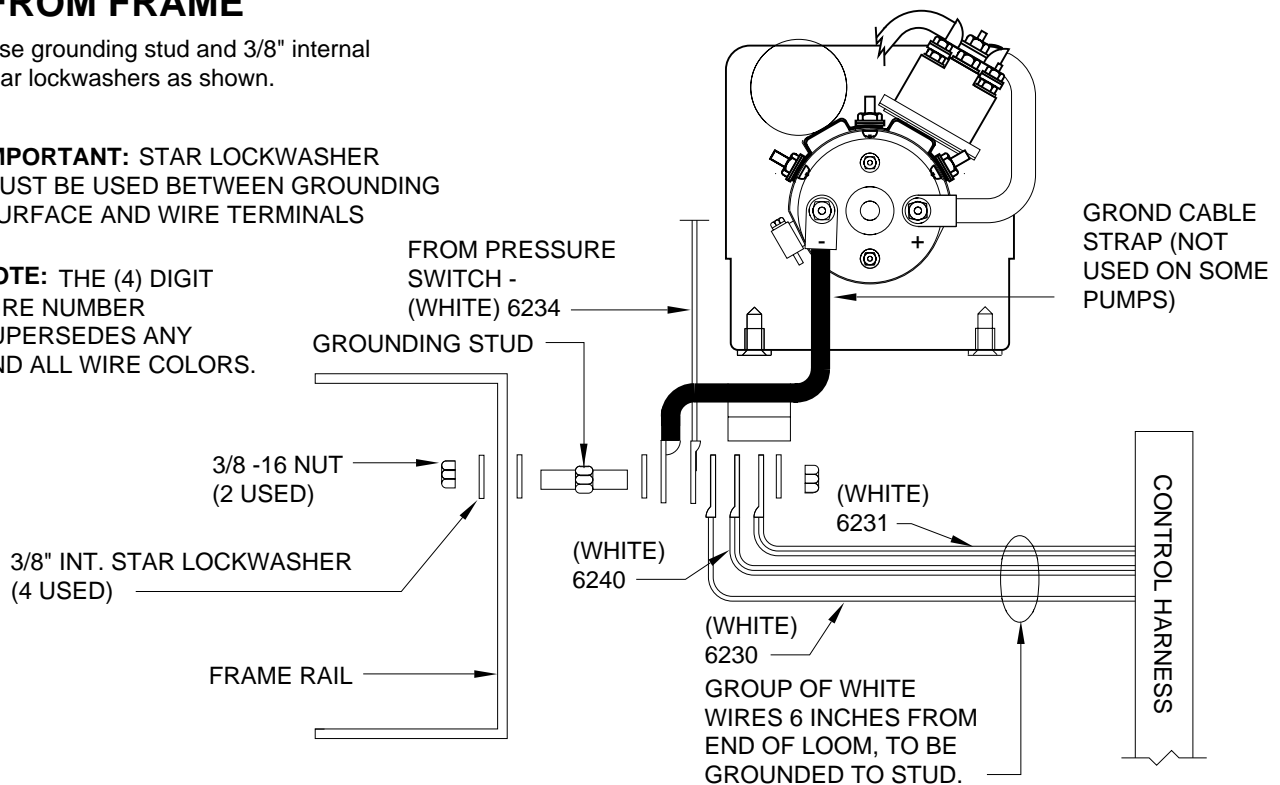

MASTER LIGHT/BUZZER CONNECTION DIAGRAM COMPUTER-CONTROLLED 610 SERIES LEVELING SYSTEMS

A MASTER WARNING INDICATOR SHOULD ALWAYS BE USED. WHEN THE LEVELING SYSTEM HAS STRAIGHT ACTING JACKS A WARNING BUZZER MUST BE USED.

WHEN ONLY A RED MASTER WARNING LIGHT IS USED THE 12+ POWER FOR THE LIGHT COMES THROUGH THE CONTROL PANEL. (SEE FIGURE 1 BELOW). WHEN BOTH A RED LIGHT AND WARNING BUZZER ARE USED THE +12 POWER FOR BOTH INDICATORS IS SUPPLIED BY THE IGNITION SWITCH. THE POWER MUST COME FROM THE "ON" SIDE OF THE IGNITION SWITCH, NOT THE "ACC" SIDE. (SEE FIGURE 2 BELOW)

NOTE : BY SUPPLYING IGNITION POWER TO THE WARNING BUZZER AND LIGHT, AND "ACC" POWER TO THE CONTROL PANEL, THE SYSTEM MAY BE OPERATED IN ACCESSORY WITHOUT THE BUZZER SOUNDING. THE NEGATIVE SIGNAL FOR THE WARNING INDICATORS MUST ALWAYS COME FROM THE CONTROL BOX.

CAUTION: THE (PURPLE) 6121 WIRE IN THE MASTER WARNING LIGHT HARNESS IS HOT WHENEVER THE IGNITION IS "ON" OR "ACC". THE (PURPLE) 6121 WIRE MUST BE REMOVED FROM THE HARNESS WHEN USING DIRECT IGNITION VOLTAGE FOR THE MASTER WARNING INDICATORS.

NOTE : THE (4) DIGIT WIRE NUMBER SUPERSEDES ANY AND ALL WIRE COLORS.

