

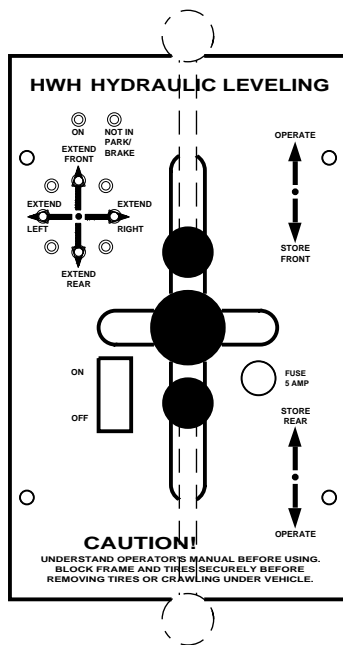

OPERATOR'S MANUAL

HWH® JOYSTICK-CONTROLLED 210 SERIES LEVELING SYSTEM

FEATURING:
Joystick BI-AXIS® Control
Hydraulic Leveling
Kick-Down Jacks



HWH CORPORATION
(On I-80, Exit 267 South)
2096 Moscow Road | Moscow, Iowa 52760
Ph: 800/321-3494 (or) 563/724-3396 | Fax: 563/724-3408
www.hwh.com

AP13385 - U.S.
AP15005 - Europe

ML13048/MP05.2004
26FEB04

OPERATOR'S MANUAL

CAUTION !

READ THE ENTIRE OPERATOR'S MANUAL BEFORE OPERATING.

BLOCK FRAME AND TIRES SECURELY BEFORE CRAWLING UNDER VEHICLE. DO NOT USE LEVELING JACKS OR AIR SUSPENSION TO SUPPORT VEHICLE WHILE UNDER VEHICLE OR CHANGING TIRES. VEHICLE MAY DROP AND/OR MOVE FORWARD OR BACKWARD WITHOUT WARNING CAUSING INJURY OR DEATH.

KEEP ALL PEOPLE CLEAR OF VEHICLE WHILE LEVELING SYSTEM AND ROOM EXTENSION ARE BEING OPERATED.

THE JACKS MAY ABRUPTLY SWING UP WHEN THE FOOT CLEARS THE GROUND OR WHEN JACK REACHES FULL EXTENSION.

NEVER PLACE HANDS OR OTHER PARTS OF THE BODY NEAR HYDRAULIC LEAKS. OIL MAY PENETRATE SKIN CAUSING INJURY OR DEATH.

WEAR SAFETY GLASSES WHEN INSPECTING OR SERVICING THE SYSTEM TO PROTECT EYES FROM DIRT, METAL CHIPS, OIL LEAKS, ETC. FOLLOW ALL OTHER APPLICABLE SHOP SAFETY PRACTICES.

IF THIS VEHICLE IS EQUIPPED WITH KICK-DOWN STYLE JACKS, DO NOT OVER EXTEND THE REAR JACKS. IF THE WEIGHT OF THE VEHICLE IS REMOVED FROM ONE OR BOTH REAR WHEELS, THE VEHICLE MAY ROLL FORWARD OR BACKWARD OFF THE JACKS.

NOTE: KEEP THE CONTROL VALVE LEVERS IN THE STORE POSITION WHEN JACKS ARE NOT IN USE.

IMPORTANT: IF VEHICLE IS EQUIPPED WITH A ROOM EXTENSION, READ ROOM EXTENSION SECTION BEFORE OPERATING LEVELING SYSTEM.

HOW TO OBTAIN WARRANTY SERVICE

THIS IS NOT TO BE INTERPRETED AS A STATEMENT OF WARRANTY

HWH CORPORATION strives to maintain the highest level of customer satisfaction. Therefore, if you discover a defect or problem, please do the following:

FIRST: Notify the dealership where you purchased the vehicle or had the leveling system installed. Dealership management people are in the best position to resolve the problem quickly. If the dealer has difficulty solving the problem, he should immediately contact the Customer Service Department, at HWH CORPORATION.

SECOND: If your dealer cannot or will not solve the problem, notify the Customer Service Department:
HWH CORPORATION 2096 Moscow Rd. Moscow IA. 52760
(563) 724-3396 OR (800) 321-3494. Give your name and address, coach manufacturer and model year, date the coach was purchased, or the date of system installation,

description of the problem, and where you can be reached during business hours (8:00 a.m. till 5:00 p.m. c.s.t.). HWH CORPORATION personnel will contact you to determine whether or not your claim is valid. If it is, HWH CORPORATION will authorize repair or replacement of the defective part, either by appointment at the factory or by the authorization of an independent service facility, to be determined by HWH CORPORATION. All warranty repairs must be performed by an independent service facility authorized by HWH CORPORATION, or at the HWH CORPORATION factory, unless prior written approval has been obtained from proper HWH CORPORATION personnel.

CONTROL IDENTIFICATION

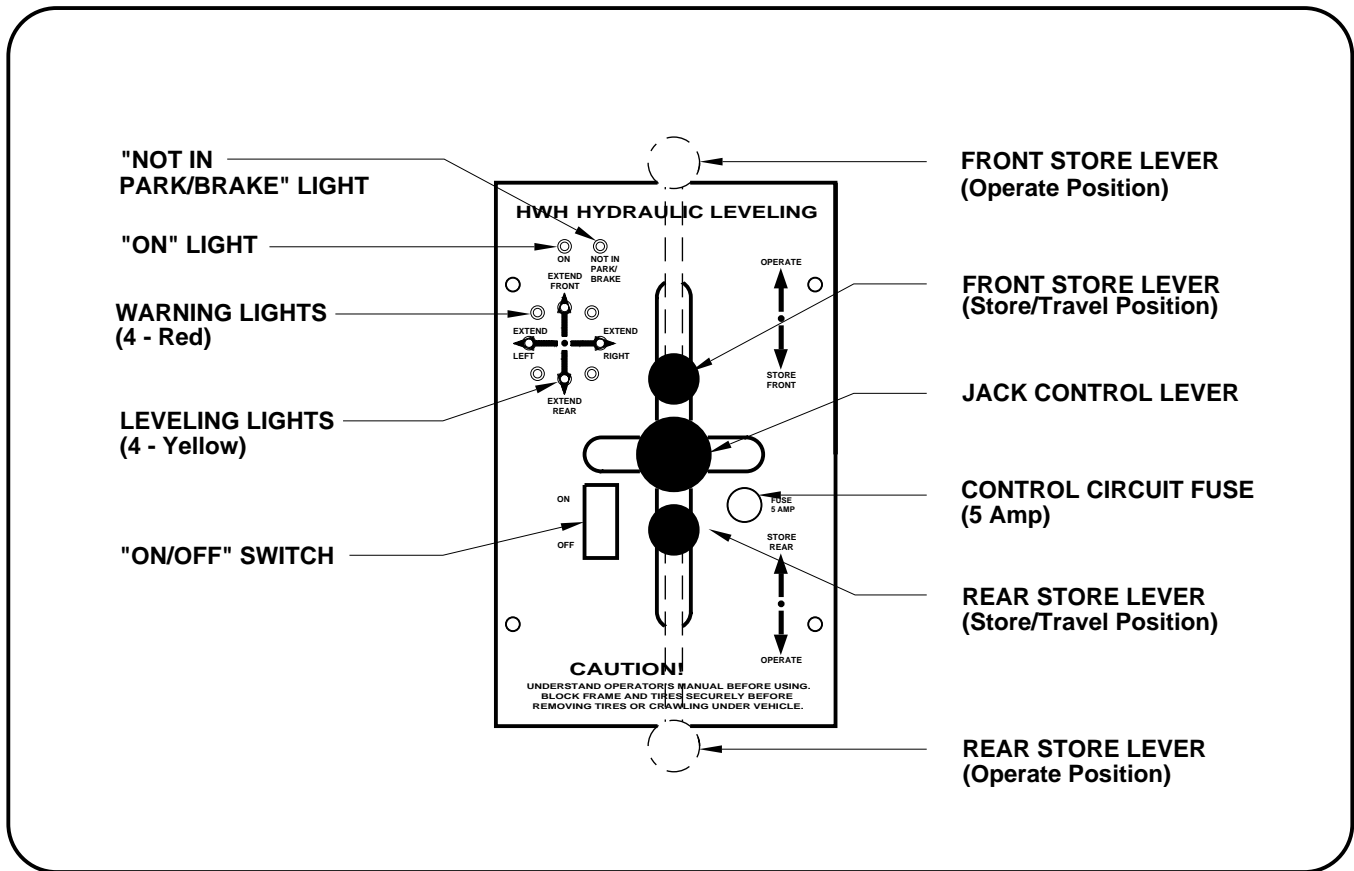

CONTROL FUNCTIONS

CONTROL BUTTONS

"ON/OFF" SWITCH: This is the "ON/OFF" switch for the leveling system. It provides control power to operate the electrical relay on the pump and the LEVELING LIGHTS. It does not control power to the four red WARNING LIGHTS or the master "JACKS DOWN" warning light.

STORE LEVERS: These two levers are used to retract the jacks into the STORE/TRAVEL position. They must be in the operate position for leveling.

JACK CONTROL LEVER: Jacks are extended in pairs by pushing the jack control lever to one of the EXTEND positions. This movement of the lever activates the pump and directs hydraulic fluid to the jacks. When the lever is released it will return to the neutral (center) position, turning off the pump and stopping jacks in position.

INDICATOR LIGHTS

ON LIGHT: This light indicates the system is on.

"NOT IN PARK/BRAKE" LIGHT: This indicator light is on when the switch is on, but the hand/auto park brake is not set.

LEVELING LIGHTS: If a yellow LEVELING light is on, that indicates a side or end of the vehicle is low. Extend the appropriate jack pairs to put out the yellow light. Only one yellow leveling light should be on at a time. The vehicle is level when all yellow lights are out.

WARNING LIGHTS: A red WARNING light will be on whenever the corresponding jack is in the vertical position provided the ignition switch is in the "ACCESSORY" or "ON" position. Some coaches are equipped with a dash mounted master "JACKS DOWN" light which will be on when one or more jacks are in the vertical position, provided the ignition switch is "ON".

OPERATING PROCEDURES

SITE SELECTION

Maintain adequate clearance in all directions for vehicle, room extensions, awnings, doors, steps, ect. Vehicle may move in any direction due to jacks extending or retracting, settling of jacks or vehicle, equipment malfunction, ect. Park with the front of the vehicle facing downhill if possible.

Care must be taken not to raise the rear of the vehicle too high or the vehicle may roll forward or backward off the jacks. If parking on soft ground or asphalt paving, wood blocks or pads should be placed under the jacks.

ROOM EXTENSION PROCEDURES

IMPORTANT: If the vehicle is equipped with a room extension read this section carefully.

Refer to the vehicle owner's manual for proper operation of room extensions.

If the vehicle is equipped with kick-down jacks, the wheels **MUST** be blocked securely. Do **NOT** operate any room extension until the leveling and stabilizing procedure is complete. Do **NOT** retract the leveling system until all room extensions are retracted. **NEVER** operate the leveling system when any room extensions are extended.

IMPORTANT: Do not use a room extension support when the vehicle is supported by the leveling system.

LEVELING PROCEDURE

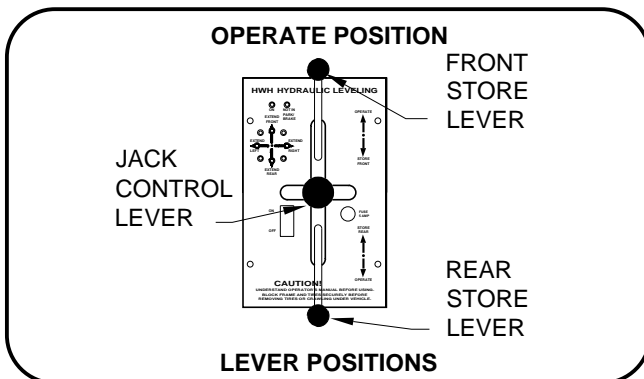

1. Place gear selector in the parking position, apply park brake and block tires securely.

NOTE: If the hand/auto park brake is not set, the "NOT IN PARK/BRAKE" light will come on when the "ON/OFF" switch is on. The pump will not run if the park brake is not set.

2. Turn ignition switch to "ON" or "ACCESSORY".

3. Push the "ON/OFF" switch to the "ON" position. The POWER ON light will be lit.

4. Move the FRONT and REAR STORE LEVERS to the OPERATE POSITION. Nothing should happen at this time.

5. Swing the jacks to the vertical position by pushing the center jack control lever to FRONT EXTEND then REAR EXTEND. The respective red WARNING light will be lit as soon as the jack swings vertical. Check that all jacks have swung to the vertical position. Place pads under jacks if necessary at this time.

6. A lit yellow LEVEL light indicates that the end, side or corner of the vehicle is low. Only one yellow LEVEL light should be lit at a time. If a corner of the vehicle is low a side LEVEL light will be on by itself.

Move the JACK CONTROL LEVER to the extend position to extend jack pairs corresponding to a lit yellow light. Extend jack pairs accordingly until all yellow lights are out. It may take several movements from side to front, or side to rear to raise a low corner. If the ground is too uneven, the jacks may not have enough stroke to level the vehicle. The vehicle may have to be moved. Remember, if the rear of the vehicle is lifted too high, the vehicle may roll forward or backward off the jacks.

7. After the vehicle is level, the jacks not used for leveling may be extended until they touch the ground. This provides additional stability against wind and activity in the vehicle. Do this by pushing the jack control lever to the rear and/or front as needed to extend any remaining jacks, until they contact the ground and lift the vehicle approximately 3/4 of an inch. Do not use the right or left extend positions.

8. Push the "ON/OFF" switch to the "OFF" position.

9. Turn the ignition switch off.

OPERATING PROCEDURES

RETRACT PROCEDURES

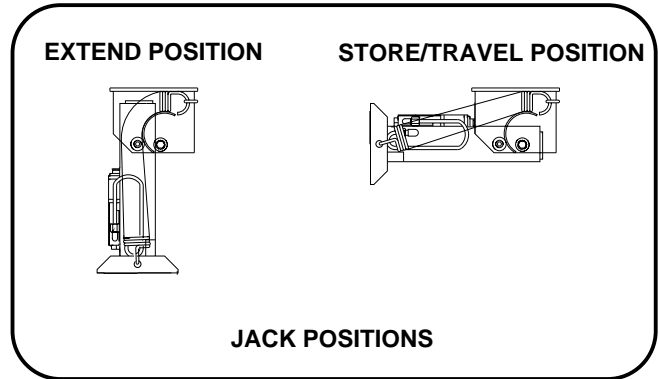
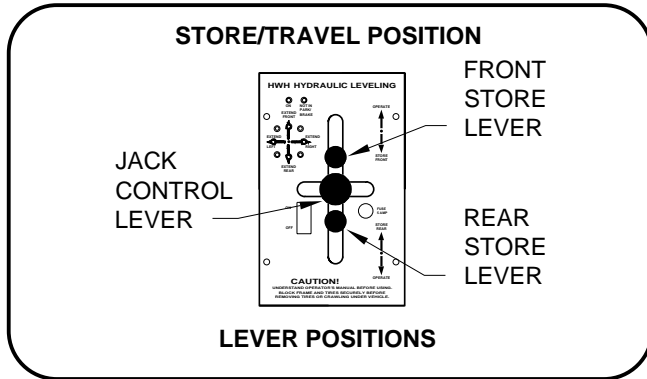

CAUTION: MAKE SURE THAT PEOPLE AND EQUIPMENT ARE CLEAR OF THE VEHICLE.

IMPORTANT: Room extensions should be fully retracted before retracting the leveling system.

1. Move the STORE LEVERS to the STORE/TRAVEL POSITION. This will allow the jacks to retract. As soon as a jack foot clears the ground, the jack will swing horizontal and continue to retract.

CAUTION: THE STORE LEVERS SHOULD BE KEPT IN THE "STORE" POSITION WHILE TRAVELING TO KEEP THE JACKS IN THE STORE/TRAVEL POSITION.

2. Visually check that all jacks are in the STORE/TRAVEL position. With the ignition switch in the "ON" or "ACCESSORY" position, the red WARNING lights and the master "JACKS DOWN" light will be out.

CAUTION: DO NOT RELY SOLELY UPON THE WARNING LIGHTS. IT IS THE OPERATOR'S RESPONSIBILITY TO CHECK THAT ALL JACKS ARE IN THE STORE/TRAVEL POSITION BEFORE MOVING THE VEHICLE.

3. Push the "ON/OFF" switch on the panel to the "OFF" position. Turn ignition off or proceed to travel.

NOTE: If the vehicle is parked or stored with the jacks extended for an extended period of time and the jacks fail to retract completely, extend the jacks back down to the ground then retract the jacks again.

MAINTENANCE

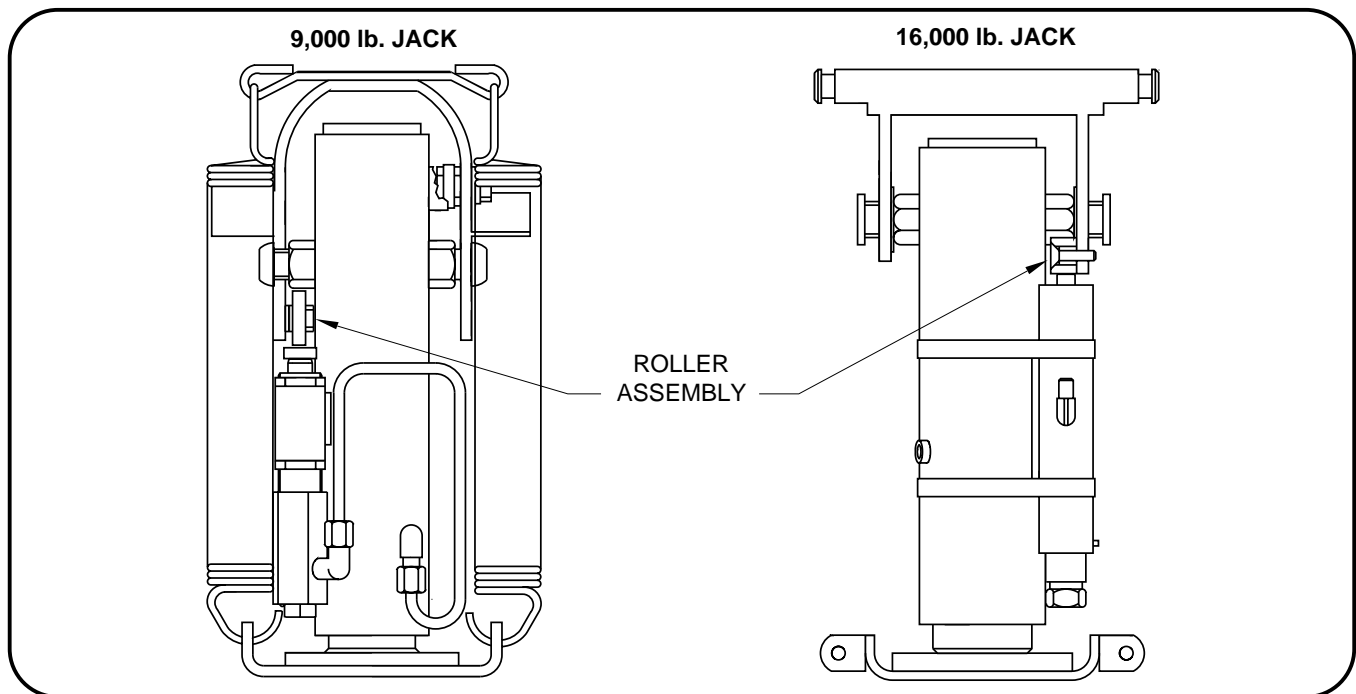

FLUID LEVELS

It is important that all of the jacks are fully retracted before checking the hydraulic oil level. To check the oil supply, remove the breather cap from the top of the hydraulic oil reservoir. The oil level should be approximately one inch below the top of the reservoir when adequately filled.

FLUID: HWH Specialty Hydraulic Oil is recommended. In an emergency Dexron automatic transmission fluid can be used.
NOTE: Dexron automatic transmission fluid contains red dye and can cause staining should a leak occur. **DO NOT USE** brake fluid or hydraulic jack fluid. Use of these can damage seals.

JACK MAINTENANCE

On the 9,000 lb. jacks and the 16,000 lb. jacks there are roller assemblies that need to rotate freely. (See above FIGURE) These rollers should be cleaned with a penetrating fluid, such as WD-40, and lubricated with a light oil as part of your regular maintenance schedule.

In general, to insure the smooth operation of the leveling system, it is a good idea to occasionally check the individual leveling jacks to prevent problems. This is especially true under the unusual conditions stated in the following:

UNUSUAL CONDITIONS

If driving conditions are unusually muddy, the jacks may become caked or clogged with mud. This condition may hamper the proper operation of the leveling system. This problem may be prevented or remedied by cleaning off each leveling jack if they become excessively muddy.

Do not move the vehicle while the leveling jacks are still in contact with the ground. However, if this should accidentally happen, the leveling system was designed to protect itself from damage in most cases. Place the system in the STORE mode and then visually check to see if the leveling jacks have returned to the STORE/TRAVEL POSITION.

In wet or icy weather leveling jacks may become encrusted with ice. This may cause the leveling system to function improperly. To eliminate this problem, periodically check the leveling jacks and break loose any ice which may be causing improper operation.

NOTE: All major components of the system can be replaced with rebuilt parts or can be sent to HWH CORPORATION to be rebuilt, when the system is out of warranty.

ELECTRICAL SYSTEM

The batteries should be in good condition and fully charged. Weak batteries can cause erratic operation. Battery cable terminals and battery posts and connections should be kept

clean. All electrical connections, especially ground connections, should be clean, tight, free from corrosion and protected from weathering.

MAINTENANCE

SYSTEM ADJUSTMENT

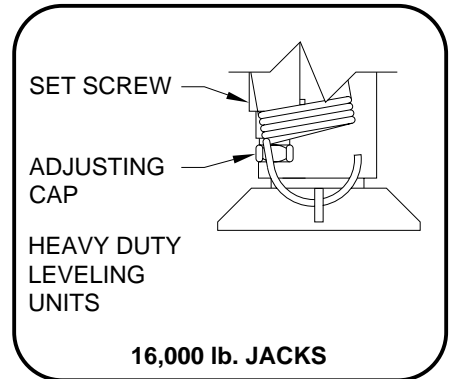
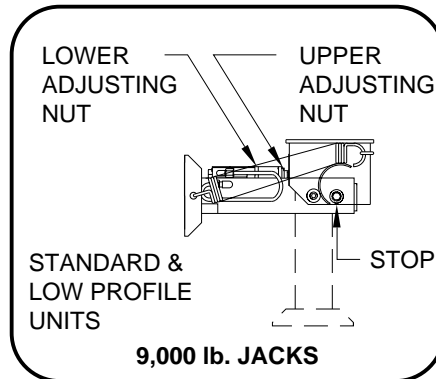
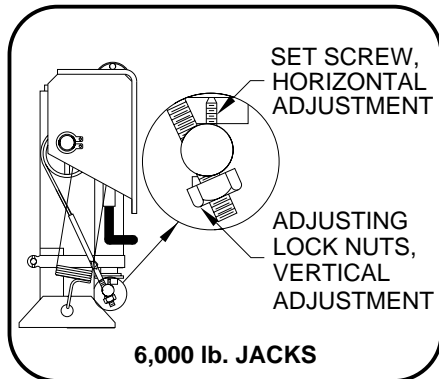

JACK ADJUSTMENT

There are two basic adjustments which are made at the time of installation. However, when adjustment of a leveling unit is needed, the following procedures are recommended.

1. 6,000 lb. JACKS: Always make vertical adjustment first. If the vertical adjustment is changed at anytime, be sure to check the horizontal adjustment. Vertical position is changed by adjusting the lock nuts on the actuator cable. If the jack stopped short of vertical, tighten the lock nuts. If the jack goes past vertical, back the lock nuts off. Be sure to adjust each nut the same number of turns.

NOTE: The two front jacks should be adjusted to the same horizontal position.

Horizontal stop is adjusted by turning the set screws located just inside the cable locknuts. The jack can be adjusted down to provide clearance for objects which may interfere with the operation of the jacks. The horizontal stop must be adjusted to provide clearance between the hat bracket and mounting bolts; and the actuator and hose fittings, when the jack is in the STORE POSITION. The jack must be able to fully extend in the horizontal position without interfering with suspension components, tanks, etc.

2. 9,000 lb. JACKS: Each jack should be checked to be sure that it is vertical when it swings down. To do this, retract all jacks, then extend each jack until it is close to, but not touching the ground. If the jack stopped short of being vertical, it can be adjusted by loosening the lower adjusting nut and tightening the upper nut.

The horizontal stop can be adjusted up or down in the slot to provide clearance for objects which may interfere with operation of the jack. The stop must be adjusted so that the jack can be fully extended in the horizontal position without interfering with suspension components, tanks, etc.

3. 16,000 lb. JACKS: If the jack stopped short of being vertical loosen the set screw and turn the adjusting cap clockwise. If the jack went beyond vertical, loosen the set screw and turn the adjusting cap counterclockwise. After each adjustment, the weight of the vehicle must be applied to the jack to make the adjustment effective. DO NOT adjust cap more than one turn without cycling the jack.

The horizontal stop on the heavy-duty jack is adjusted by adding washers under the urethane stop.

LEVEL SENSING UNIT ADJUSTMENT

Level the vehicle by placing a circular bubble level in the center of the freezer floor or location within the vehicle that is to be level. With the vehicle level, adjust the sensing unit until all yellow lights are off. This is done by drawing up the corresponding screw if the sensing unit is mounted below the surface as shown or backing out the corresponding screw if the sensing unit is mounted above the surface. Bump the sensing unit to see that it is settled tight against all three screw heads and still indicates that the unit is level.

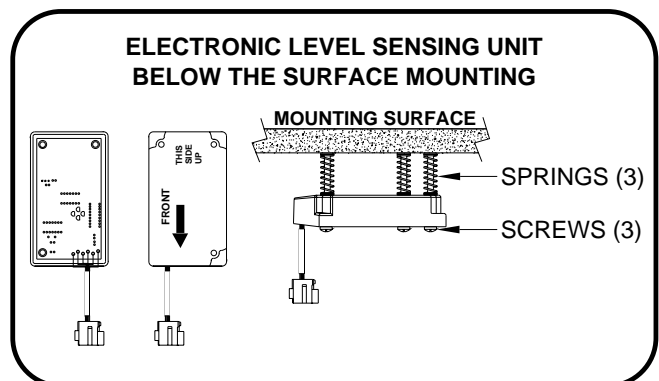

TROUBLE SHOOTING

210/225 SERIES BI-AXIS VALVE

The following is a list of problems, and possible solutions, which might occur to the leveling system.

NOTE: Only qualified technicians should install or repair leveling systems on vehicles. A knowledge of hydraulics, welding, the vehicle's suspension and electrical system, as well as an understanding of the leveling system's hydraulics and electronics is required.

1. JACK RETRACTS AFTER COACH IS LEVEL.

- A. Hose or jack has external leak.
- B. Fluid is leaking back to reservoir through control valve.

2. LEVELING JACKS WILL NOT RETRACT COMPLETELY.

- A. Actuator rod bent or scored (rod will not move freely).
- B. Jack clogged with mud or ice.
- C. Main rod bent or scored.
- D. Valve plunger not completely depressed by valve handle.
- E. Springs weak or broken.
- F. Hydraulic line pinched.

3. UNIT IS EXTENDED BUT NOT VERTICAL.

- A. Move the store lever to the "STORE" position and wait two minutes. Be sure the jack is fully retracted, then try again.
- B. Roller assembly frozen or missing.
- C. Actuator rod bent.
- D. Actuator not functioning properly.

4. IGNITION SWITCH ON, BUT NO POWER TO PUMP AND/OR LIGHTS.

- A. Park brake not set.
- B. 12 or 24 volts (as applicable) from main power source not present.
- C. Faulty PC board.
- D. Faulty wire or electrical connection.

5. PUMP WILL NOT ACTIVATE.

- A. Grounding switch on valve not working.
- B. Pump relay not functioning.
- C. Pump not grounded.

6. HYDRAULIC PUMP ACTIVATES WITHOUT USE OF CONTROL VALVE HANDLES.

- A. Grounding switch at valve shorted.
- B. Pump relay stuck.
- C. Relay control wire shorted to ground.

7. HYDRAULIC PUMP ACTIVATES, BUT THE JACKS WILL NOT EXTEND.

- A. Store levers not in the operate position.
- B. Oil supply low in reservoir.
- C. Pump is not developing pressure.
- D. Broken hydraulic line.

8. LEVELING LIGHTS (YELLOW) NOT FUNCTIONING PROPERLY.

- A. Yellow lights will not go out when vehicle is level: adjust sensing unit.
- B. If two or more lights are on replace PC board and check sensing unit

9. WARNING LIGHTS (RED) NOT FUNCTIONING PROPERLY.

- A. Light will not come on: check for broken wire at warning switch on the jack.
- B. Lights will not go out bad warning switch or wires are shorted to ground.
- C. Check PC board.

HYDRAULIC LINE CONNECTION DIAGRAM 200/210/225 SERIES BI-AXIS VALVE

NOTE: Hose fittings at the pump will come directly out of the pump or if equipped with a room manifold, out of the top of the room manifold.

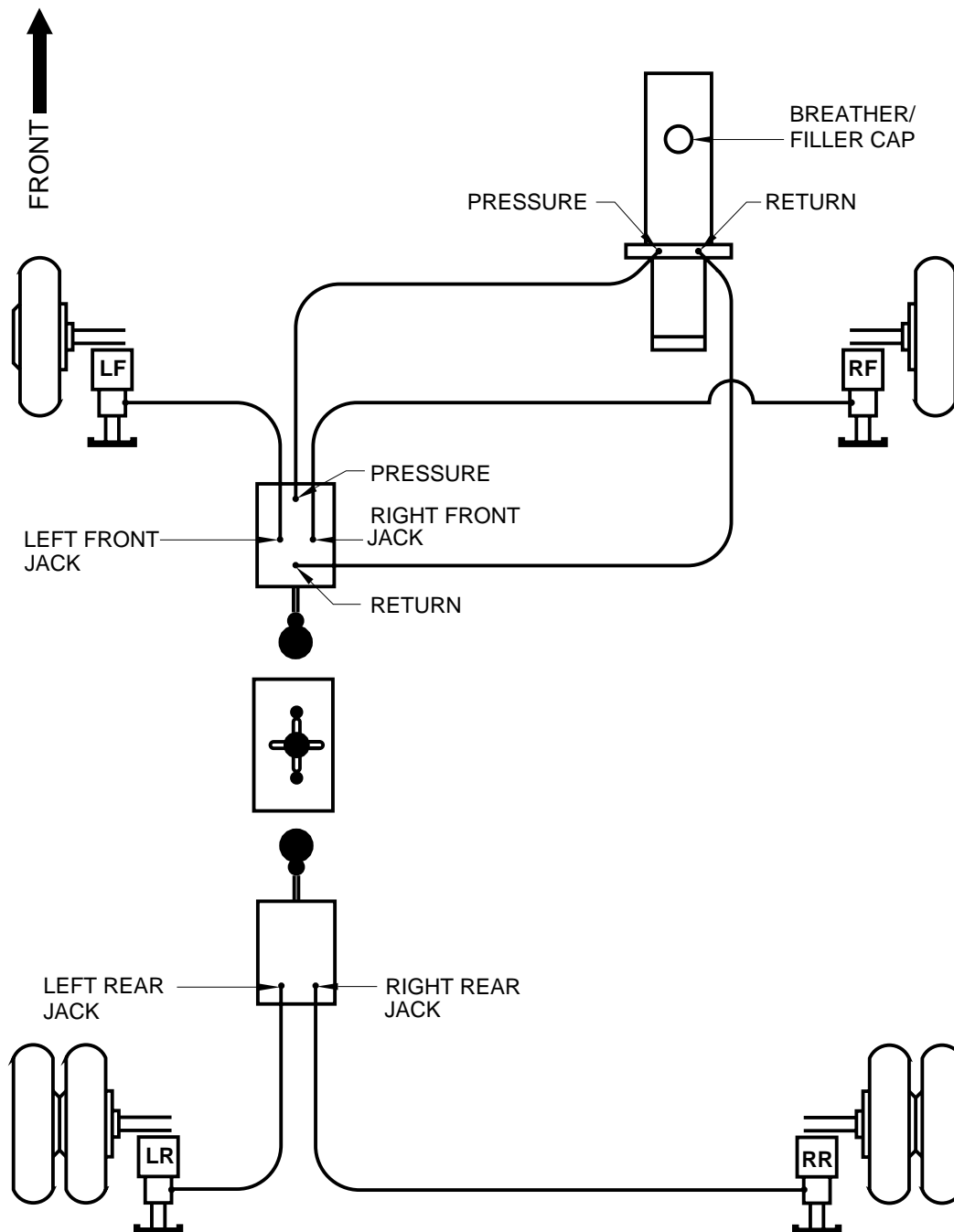

ELECTRICAL CONNECTION DIAGRAM 210 SERIES BI-AXIS VALVE

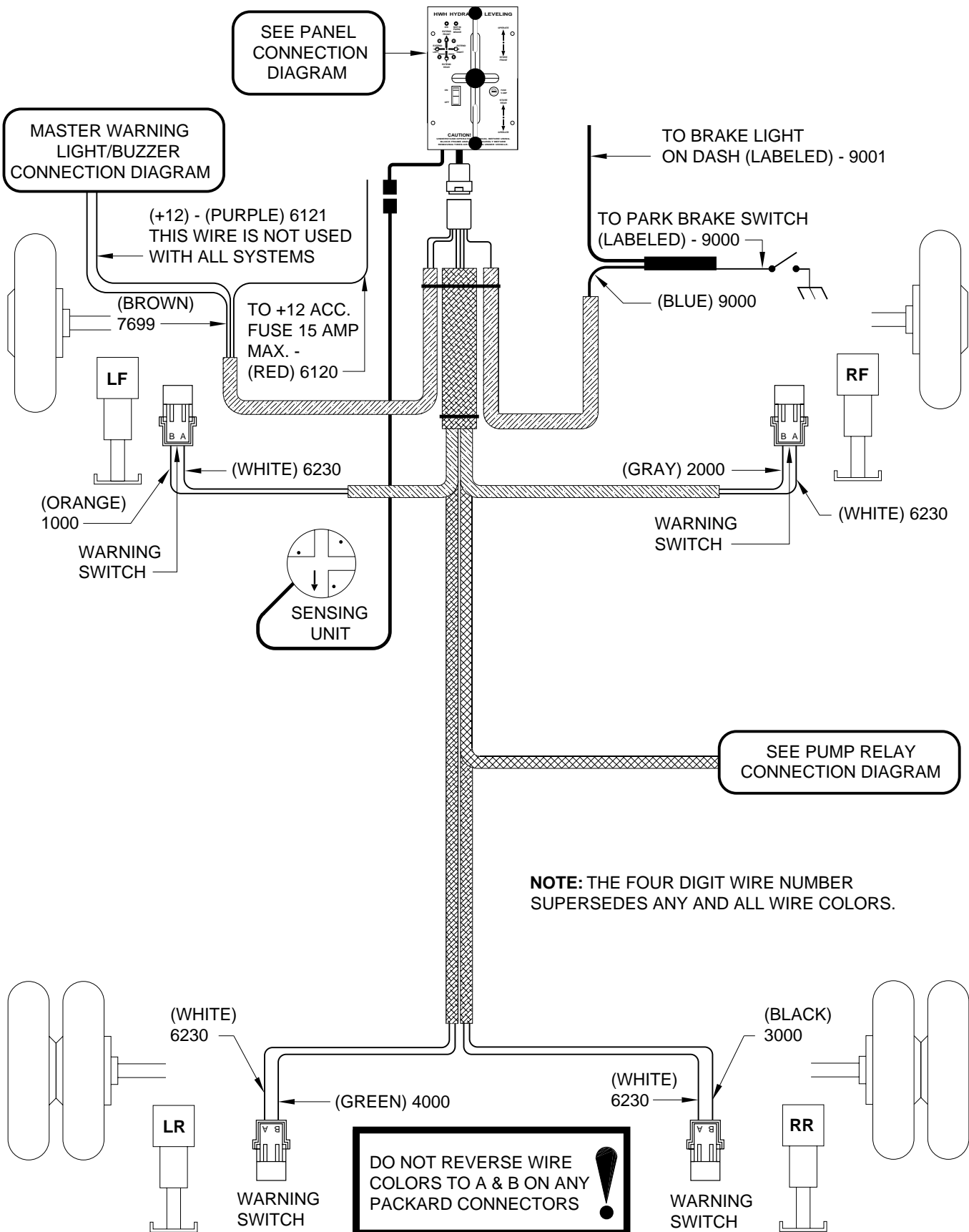

ELECTRICAL CONNECTION DIAGRAM

200/210/225 SERIES BI - AXIS VALVE

PUMP RELAY

PUMP RELAY CONNECTION DIAGRAM

PUMP MUST BE MOUNTED SOLIDLY TO FRAME. SOME PUMPS HAVE A GROUND CABLE THAT IS TO BE ATTACHED TO THE GROUND STUD.

NOTE: THE FOUR DIGIT WIRE NUMBER SUPERSEDES ANY AND ALL WIRE COLORS.

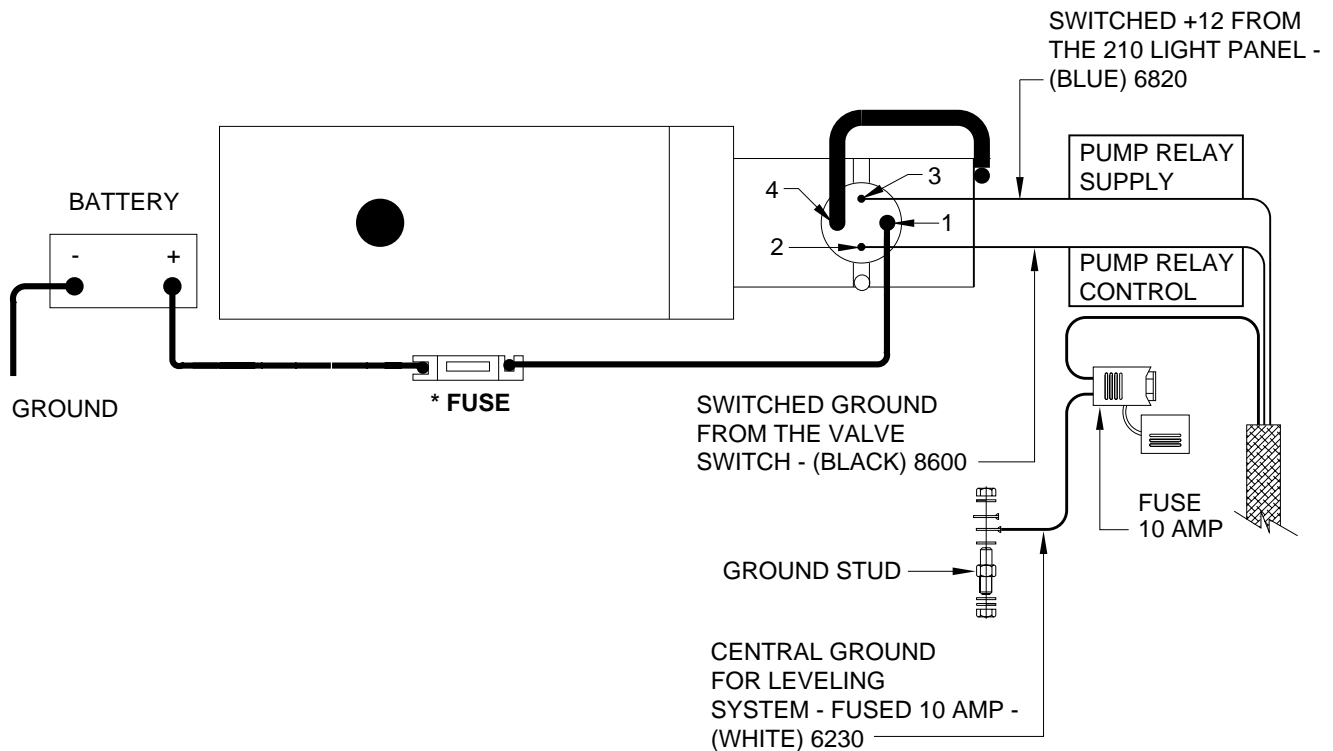

NOTE: IF THE PUMP BRACKET IS WELDED TO THE FRAME, USE THE GROUND STUD TO ATTACH THE PUMP TO THE BRACKET. IF THE PUMP BRACKET IS BOLTED TO THE FRAME, USE THE GROUND STUD TO ATTACH THE BRACKET TO THE FRAME.

* FUSE MAY BE REQUIRED - CHECK APPLICABLE CODE

ELECTRICAL CONNECTION DIAGRAM

210 SERIES PANEL CONNECTIONS

SENSING UNIT CONNECTIONS

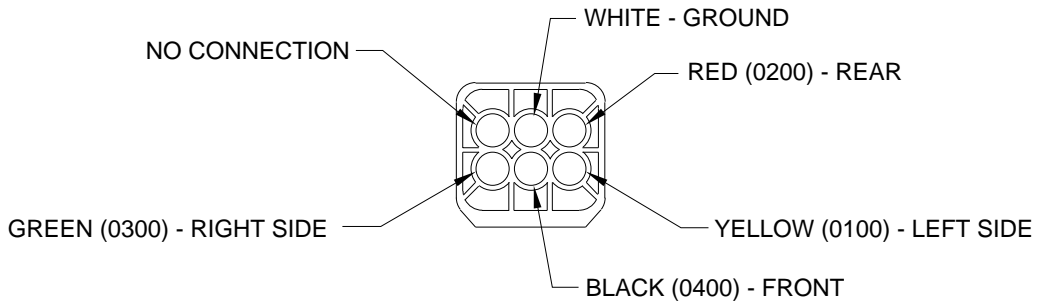
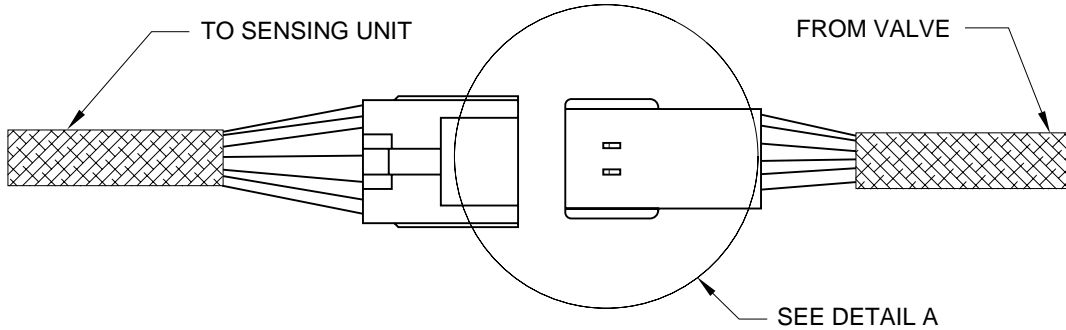

DETAIL A

PUMP AND WARNING SWITCH CONNECTIONS

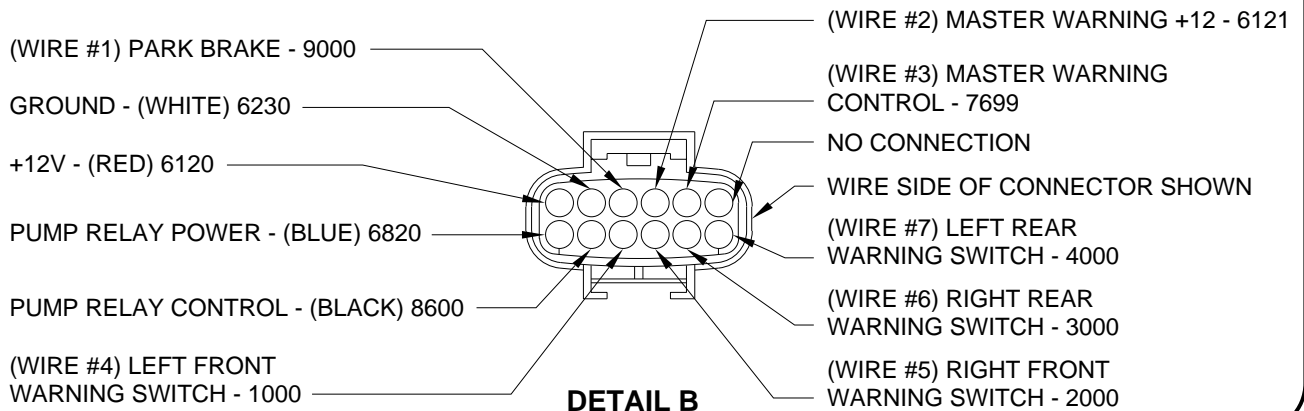
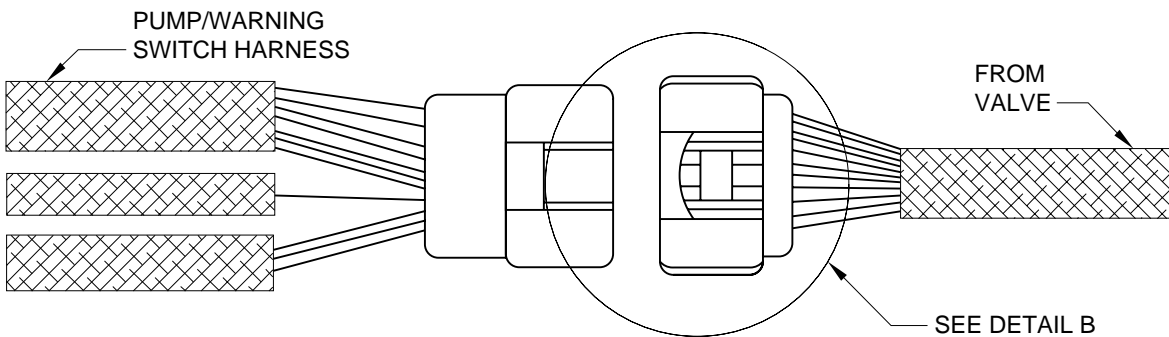

DETAIL B

ELECTRICAL SCHEMATIC LIGHT PANEL

210 SERIES LEVELING SYSTEM W/KICK-DOWN JACKS

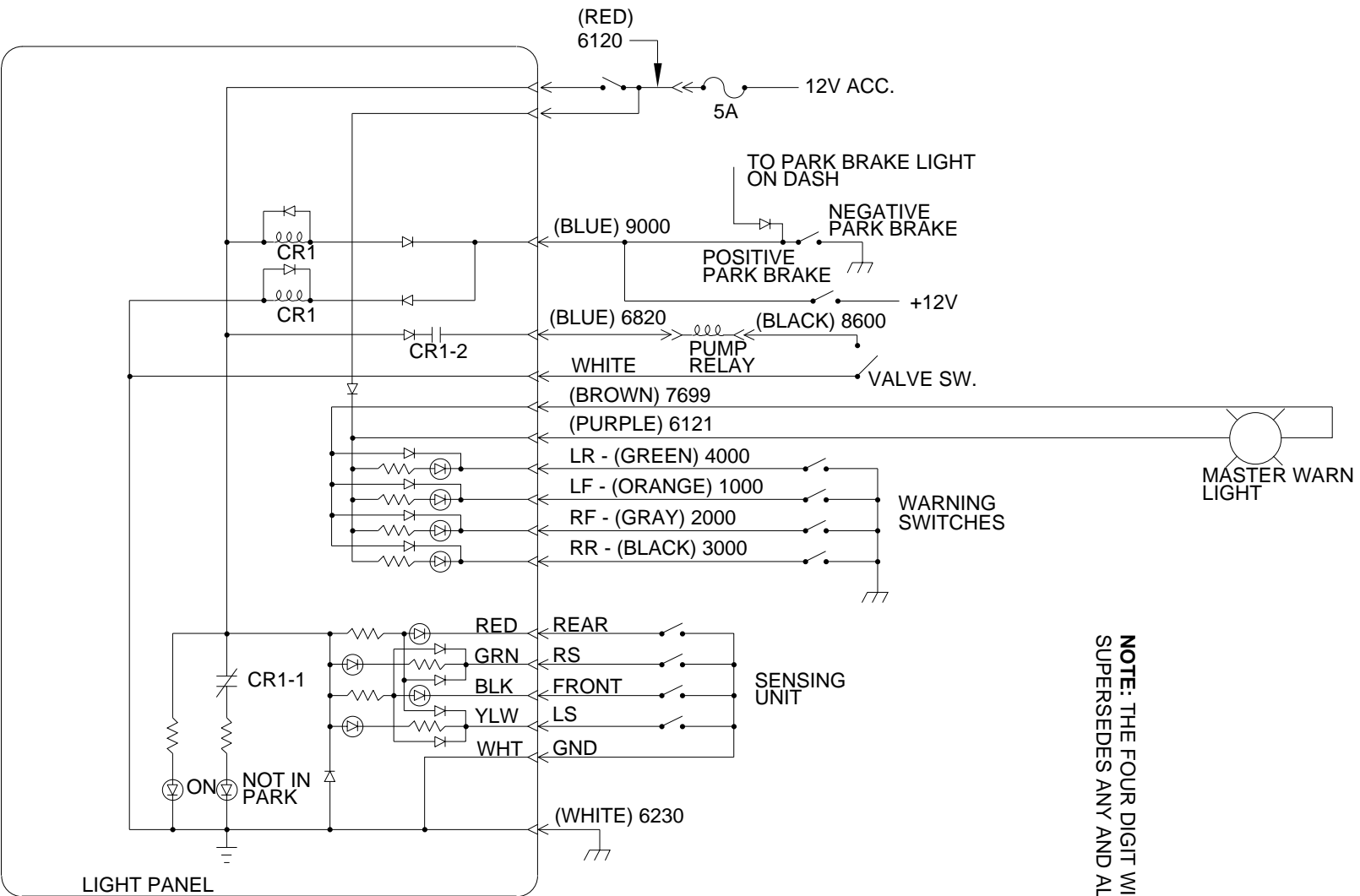

MASTER LIGHT/BUZZER CONNECTION DIAGRAM MANUAL LEVELING SYSTEMS

A MASTER WARNING INDICATOR SHOULD ALWAYS BE USED. WHEN THE LEVELING SYSTEM HAS STRAIGHT-ACTING JACKS A WARNING BUZZER MUST BE USED.

WHEN ONLY A RED MASTER WARNING LIGHT IS USED THE +12 POWER FOR THE LIGHT COMES THROUGH THE CONTROL PANEL. (SEE FIGURE 1 BELOW.) WHEN BOTH A RED LIGHT AND WARNING BUZZER ARE USED THE +12 POWER FOR BOTH INDICATORS IS SUPPLIED BY THE IGNITION SWITCH. THE POWER MUST COME FROM THE "ON" SIDE OF THE IGNITION SWITCH, NOT THE "ACC" SIDE. (SEE FIGURE 2 BELOW)

NOTE: BY SUPPLYING IGNITION POWER TO THE WARNING BUZZER AND LIGHT, AND "ACC" POWER TO THE CONTROL PANEL, THE SYSTEM MAY BE OPERATED IN ACCESSORY WITHOUT THE BUZZER SOUNDING. THE NEGATIVE SIGNAL FOR THE WARNING INDICATORS MUST ALWAYS COME FROM THE CONTROL PANEL.

CAUTION: THE PURPLE WIRE IN THE MASTER WARNING LIGHT HARNESS IS HOT WHENEVER THE IGNITION IS "ON" OR IN "ACC". THE PURPLE WIRE MUST BE REMOVED FROM THE HARNESS WHEN USING DIRECT IGNITION VOLTAGE FOR THE MASTER WARNING INDICATORS.

NOTE: THE (4) DIGIT WIRE NUMBER SUPERSEDES ANY AND ALL WIRE COLORS.

