



OPERATOR'S MANUAL

HWH® COMPUTER-CONTROLLED 2000 SERIES LEVELING SYSTEM

FEATURING:

*Touch Panel Leveling Control
Air Leveling (With Tag Axle)*

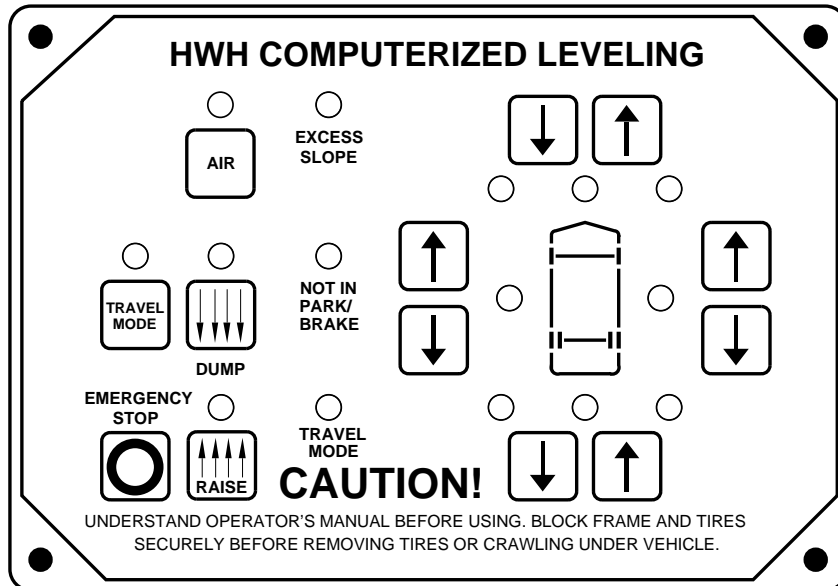

HWH CORPORATION

(On I-80, Exit 267 South)

2096 Moscow Road | Moscow, Iowa 52760

Ph: 800/321-3494 (or) 563/724-3396 | Fax: 563/724-3408

www.hwh.com

OPERATOR'S MANUAL

CAUTION !

READ THE ENTIRE OPERATOR'S MANUAL BEFORE OPERATING.

BLOCK FRAME AND TIRES SECURELY BEFORE CRAWLING UNDER VEHICLE. DO NOT USE LEVELING JACKS OR AIR SUSPENSION TO SUPPORT VEHICLE WHILE UNDER VEHICLE OR CHANGING TIRES. VEHICLE MAY DROP AND/OR MOVE FORWARD OR BACKWARD WITHOUT WARNING CAUSING INJURY OR DEATH.

KEEP ALL PEOPLE CLEAR OF VEHICLE WHILE LEVELING SYSTEM AND ROOM EXTENSION ARE BEING OPERATED.

NEVER PLACE HANDS OR OTHER PARTS OF THE BODY NEAR HYDRAULIC LEAKS. OIL MAY PENETRATE SKIN CAUSING INJURY OR DEATH.

DO NOT OPERATE THE LEVELING SYSTEM OR USE THE DUMP OR RAISE BUTTONS IF THE VEHICLE IS MOVING IN EXCESS OF 5 MPH.

WEAR SAFETY GLASSES WHEN INSPECTING OR SERVICING THE SYSTEM TO PROTECT EYES FROM DIRT, METAL CHIPS, OIL LEAKS, ETC. FOLLOW ALL OTHER APPLICABLE SHOP SAFETY PRACTICES.

IMPORTANT: IF COACH IS EQUIPPED WITH A ROOM EXTENSION, READ ROOM EXTENSION SECTION BEFORE OPERATING LEVELING SYSTEM.

HOW TO OBTAIN WARRANTY SERVICE

THIS IS NOT TO BE INTERPRETED AS A STATEMENT OF WARRANTY

HWH CORPORATION strives to maintain the highest level of customer satisfaction. Therefore, if you discover a defect or problem, please do the following:

FIRST: Notify the dealership where you purchased the vehicle or had the leveling system installed. Dealership management people are in the best position to resolve the problem quickly. If the dealer has difficulty solving the problem, he should immediately contact the Customer Service Department, at HWH CORPORATION.

SECOND: If your dealer cannot or will not solve the problem, notify the Customer Service Department:
HWH CORPORATION 2096 Moscow Rd. Moscow IA. 52760
(563) 724-3396 OR (800) 321-3494. Give your name and address, coach manufacturer and model year, date the coach was purchased, or the date of system installation,

description of the problem, and where you can be reached during business hours (8:00 a.m. till 5:00 p.m. c.s.t.). HWH CORPORATION personnel will contact you to determine whether or not your claim is valid. If it is, HWH CORPORATION will authorize repair or replacement of the defective part, either by appointment at the factory or by the authorization of an independent service facility, to be determined by HWH CORPORATION. All warranty repairs must be performed by an independent service facility authorized by HWH CORPORATION, or at the HWH CORPORATION factory, unless prior written approval has been obtained from proper HWH CORPORATION personnel.

CONTROL IDENTIFICATION

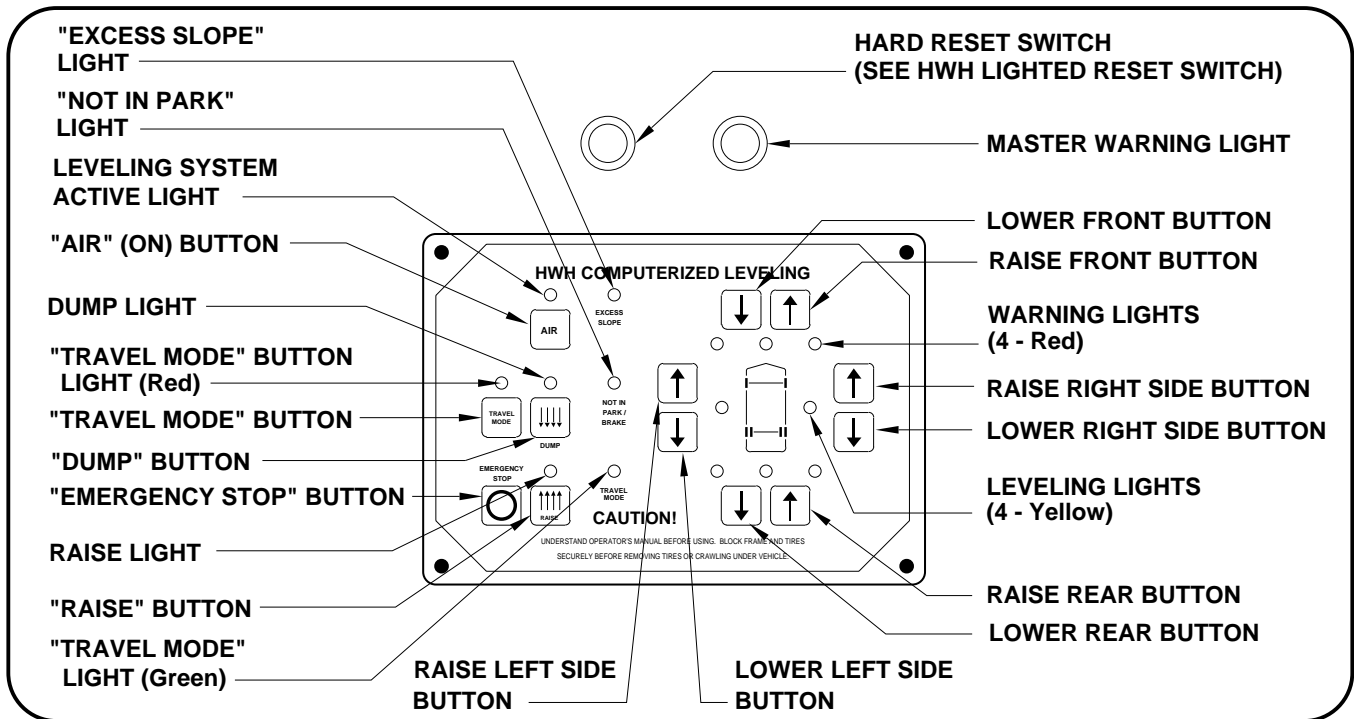

CONTROL FUNCTIONS

CONTROL BUTTONS

"AIR" BUTTON: This is the system active and automatic operation button. It works if the ignition is in the "ON" position.

"EMERGENCY STOP" BUTTON: This button turns the system OFF but does NOT control power to the "DUMP" or "RAISE" buttons. Pushing this button will NOT put the system in the TRAVEL mode.

"TRAVEL MODE" BUTTON: This button will put the Leveling System in the TRAVEL mode. The ignition must be "ON" for the vehicle to return to proper ride height for traveling.

"DUMP" BUTTON: This button will lower the whole coach by dumping air from the suspension system.

"RAISE" BUTTON: This button will raise the whole coach by adding air to the suspension system.

IMPORTANT: Read "DUMP AND RAISE FUNCTIONS" before using the "DUMP" or "RAISE" buttons.

UP ARROWS (RAISE BUTTONS): These momentary buttons are used for manually operating the air leveling systems. Sides or ends of the vehicle will raise while these buttons are pushed.

DOWN ARROWS (LOWER BUTTONS): These momentary buttons are used for manually operating the air leveling systems. Sides or ends of the vehicle will lower while these buttons are pushed.

INDICATOR LIGHTS

LEVEL SYSTEM ACTIVE LIGHT: ON when the system is active, and flashes during automatic leveling.

DUMP LIGHT: Flashes when "DUMP" button is pushed.

RAISE LIGHT: Flashes when "RAISE" button is pushed.

"EXCESS SLOPE" LIGHT: ON if the leveling system can NOT level the coach.

"TRAVEL MODE" BUTTON LIGHT (RED): Light flashes for 3 seconds after the "TRAVEL MODE" button is pushed.

"TRAVEL MODE" LIGHT (GREEN): ON if the ignition is in the "ON" position, the system is not being used, and there is sufficient air pressure in the suspension. See PREPARATION FOR TRAVEL.

WARNING LIGHTS: Function with the ignition in the "ON" position. ON when the LEVELING SYSTEM ACTIVE LIGHT is ON. See PREPARATION FOR TRAVEL.

LEVELING LIGHTS: One or two yellow lights can be on indicating the side, end or corner of the coach is low.

"NOT IN PARK/BRAKE" LIGHT: ON while the "AIR" button is being pushed if the Park Brake is NOT set. The light will go out when the "AIR" button is released.

MASTER WARNING LIGHT: ON any time the "TRAVEL" light is not ON, if the ignition is in the "ON" position.

OPERATING PROCEDURES

NETWORK INFORMATION

The HWH 2000 series CAN system is a computerized modular network. It controls all functions of the leveling system and HWH room extensions. The network is active any time the ignition is in the "ON" or "ACC" position or when any room extension control panel key is "ON". Certain functions and indicator lights for the leveling system will work when the network is active. Certain functions and lights will work ONLY if the the ignition is in the "ON" or "ACC" position to start the function.

NOTE: The network will stay active for 10 minutes after the ignition key has been turned "OFF". If the leveling system was turned "ON", the network will stay active for 10 minutes after automatic leveling is complete or the system goes "EXCESS SLOPE". If manual leveling buttons were used, the network stays active for 10 minutes after the last manual button is released.

GENERAL INSTRUCTIONS

Maintain adequate clearance in all directions for vehicles, room extensions, doors, steps, etc.. Vehicle may move in any direction due to raising or lowering of vehicle during leveling, settling of vehicle, equipment malfunction, etc..

The "DUMP" and "RAISE" buttons will function with the leveling system and park brake off, if the ignition is in the "ON" or "ACC" position or if the network is active. See AIR DUMP AND RAISE FUNCTIONS section of this manual.

The MASTER WARNING LIGHT will be on if an air bag has low pressure if the ignition is in the "ON" position.

If the Park Brake is not set, the Leveling System cannot be turned ON.

CAUTION: DO NOT MOVE THE VEHICLE AT SPEEDS IN EXCESS OF 5 MPH IF THE MASTER WARNING LIGHT IS ON.

HWH LIGHTED RESET SWITCH

The HWH lighted reset switch is located on the vehicle dash. If there is a failure at any time in the HWH CAN network, the network will shut down. The leveling system will not operate. If the ignition is off, no indicator lights will come on. If the ignition is in the "ON" or "ACC" position, the lighted reset switch and the MASTER WARNING Light will come on.

If the lighted reset switch will not go out when pushed, there is a problem with the central control module of the network system. The Leveling System will not operate. The vehicle suspension will return to the travel mode if the ignition key is in the "ON" position.

If the lighted reset switch is on, the switch must be pushed before the leveling system can be operated.

CAUTION: IF THE IGNITION IS IN THE "ON" POSITION AND THE LIGHTED RESET SWITCH IS ON, THE VEHICLE CAN RETURN TO RIDE HEIGHT WITHOUT RELEASING THE PARK BRAKE.

PREPARATION FOR TRAVEL

Visually check that the vehicle is at the proper ride height for traveling.

CAUTION: IT IS THE OPERATOR'S RESPONSIBILITY TO CHECK THAT THE VEHICLE IS AT PROPER RIDE HEIGHT BEFORE TRAVELING.

The ignition must be in the "ON" position for the vehicle suspension to be in the travel mode. Also the "TRAVEL MODE" button must be pushed or the park brake released for the suspension to be in the travel mode If the Leveling System was used.

Before traveling, the MASTER WARNING light must be off and the "TRAVEL MODE" light must be ON.

A lit "TRAVEL MODE" light indicates that the HWH Leveling System is in the TRAVEL MODE. It does not indicate that the suspension is at ride height or that the coach is ready to travel.

NOTE: Low air pressure can turn the green "TRAVEL MODE" light off and turn the MASTER WARNING light on.

Refer to "DUMP" and "RAISE" FUNCTIONS operating procedures when moving the vehicle with the suspension NOT at the proper ride height.

OPERATING PROCEDURES

TAG AXLE DUMP

The tag axle dump-switch is supplied by Monaco. This is a two position switch with one position for "TRAVEL" and one position for "TAG DUMP".

IMPORTANT: Refer to Monaco for the proper use of the Tag Dump feature.

The Tag Dump switch will work only with the ignition switch in the "ON" position and the leveling system panel off.

NOTE: If the Tag Dump switch is in the dump position and the ignition key is turned on (with the leveling system panel off) the tag axle air bags will go into the dump mode.

AUTOMATIC AIR OPERATION

NOTE: The ignition must be in the "ON" or "ACC" position to use the "AIR" button. Once the operation is started, the ignition can be moved to the "OFF" position and the operation will continue.

1. Place the transmission in the proper position for parking and set the park brake. The air leveling system can only be turned on if the ignition is in the "ON" or "ACC" position. Leaving the engine running during leveling is recommended. This will provide a better air supply for leveling. The vehicle will level with the engine shut off, however more time will be required for leveling.

NOTE: With the ignition key in the "ON" or "ACC" position, the panel will not turn on if the park brake is not set. The "NOT IN PARK/BRAKE" light will be on while the "AIR" button is being pushed.

2. Press the "AIR" button once to enter the air mode. The LEVELING SYSTEM ACTIVE LIGHT will glow steady. When the ignition is in the "ON" or "ACC" position, the four red WARNING lights on the panel will come on. This indicates that the height control valves have been locked out. The vehicle should not be moved when these lights are on.

3. Press the "AIR" button a second time. The LEVELING SYSTEM ACTIVE LIGHT will start flashing and air leveling will begin. The system will attempt to level the vehicle by exhausting air from the air bags. If a level position is not achieved by lowering the vehicle, the low side and/or end of the vehicle will be raised by adding air to the air bags. When all four yellow LEVEL SENSING lights are out the leveling is complete.

NOTE: Only one or two yellow LEVEL SENSING lights may be ON at one time.

4. When all four yellow level lights are out, the LEVELING SYSTEM ACTIVE LIGHT will stop flashing and start pulsating dimly. The Leveling System is now in the SLEEP MODE. The vehicle's engine/ignition may now be turned OFF.

NOTE: After the ignition and all room extension KEY SWITCHES are turned OFF, the CAN Network stays active for 10 minutes before shutting down. Leveling System touch panel lights will stay ON during this time and go out when the CAN Network shuts down.

NOTE: If the Leveling System is in the SLEEP MODE when the Network shuts down, the computer will stay ON. The Leveling System touch panel lights will all be OFF, but the Leveling System will still be in the SLEEP MODE.

5. 30 minutes after the Leveling System enters the SLEEP MODE, the computer will monitor the LEVELING SENSING UNIT. If no leveling is needed, the computer will continue to monitor the LEVELING SENSING UNIT every 30 minutes.

6. If the vehicle needs to be relevelled, the CAN Network will become active. The Leveling System touch panel lights will come ON during the leveling procedure. The LEVELING SYSTEM ACTIVE LIGHT will flash. One or two yellow LEVELING LIGHTS will be ON. When the yellow LEVELING LIGHTS are all out, the LEVELING SYSTEM ACTIVE LIGHT will stop flashing and start pulsating dimly. The Leveling System will remain in the SLEEP MODE with the computer monitoring the LEVELING SENSING UNIT every 30 minutes, releveling the vehicle as needed.

NOTE: The CAN Network will stay active for 10 minutes after releveling the vehicle and then shut down, turning the touch panel lights OFF. This happens every time the system relevels the vehicle.

7. The SLEEP MODE will continue until the "EMERGENCY STOP" button is pushed or the park brake is released, if the ignition is in the "ON" position.

EXCESS SLOPE: The system will attempt to level the vehicle for approximately 15 to 20 minutes. After the 15 to 20 minutes, if a LEVEL SENSING light is still on, the "EXCESS SLOPE" light will come on. The LEVEL LIGHT indicator light will go out. The "EXCESS SLOPE" light will be on whenever the network is active.

The "EXCESS SLOPE" light will be on whenever the network is active until the vehicle is leveled with all yellow LEVEL indicator lights off.

OPERATING PROCEDURES

MANUAL AIR OPERATION

NOTE: The ignition must be in the "ON" or "ACC" position to use the "AIR" button. Once the operation is started, the ignition can be moved to the "OFF" position and the operation will continue.

1. Place the transmission in the proper position for parking and set the park brake. The air leveling system can only be turned on if the ignition is in the "ON" or "ACC" position. Running the vehicle engine during leveling is recommended. This will provide a better air supply for leveling. The vehicle will level with the engine shut off, however more time will be required for leveling.

NOTE: If the "NOT IN PARK/BRAKE" light is on, the leveling system cannot be turned on.

2. Press the "AIR" button once to enter the air mode. The LEVELING SYSTEM ACTIVE LIGHT indicator light will glow steady. When the ignition is in the "ON" or "ACC" position, the four red WARNING lights on the panel will come on. This indicates that the height control valves have been locked out. The vehicle should not be moved when these lights are on.

3. The vehicle can now be leveled using the RAISE (up arrow) and LOWER (down arrow) buttons on the right half of the panel in conjunction with the yellow LEVEL indicator lights. **Any side to side leveling should be done before leveling the vehicle front to rear.** Try leveling the vehicle by lowering the opposite side or end. If a level position is not achieved use the RAISE (up arrow) button to raise the low side or end. The yellow LEVEL indicator light indicates that side or end is low. When all yellow lights are out the vehicle is level.

NOTE: If the "DUMP" or "RAISE" buttons are pushed while manually leveling the vehicle with air and the ignition is in the "ON" position, the system will latch into the dump or raise mode until the "EMERGENCY STOP" button is pushed or the ignition is turned off.

4. Turn the ignition to the "OFF" position.

5. Turn the system off.

AIR DUMP AND RAISE FUNCTIONS

The "DUMP" and "RAISE" functions are provided for operator convenience for purposes such as dumping air suspension when parked in the wind, or raising or lowering the vehicle to avoid obstacles. The "DUMP" and "RAISE" buttons will function with the system on or off.

IMPORTANT: "DUMP" and "RAISE" functions will automatically turn off when the button is released. If the ignition is in the "ON" position the suspension will return to travel height.

CAUTION: REREAD CAUTIONS ON THE FIRST PAGE OF THIS MANUAL. THE VEHICLE MAY DROP OR RAISE AND/OR MOVE FORWARD OR BACKWARD WITHOUT WARNING CAUSING INJURY OR DEATH.

DO NOT OPERATE THE VEHICLE OVER 5 M.P.H. UNLESS AIR SUSPENSION IS AT THE PROPER HEIGHT FOR TRAVEL.

1. Leave the engine running if the "RAISE" function is to be used. The park brake does not have to be set and the system does not have to be on to use the "RAISE" or "DUMP" functions.

2. Press and hold the "RAISE" or "DUMP" button as desired to raise or lower the vehicle. The system will remain in the "RAISE" or "DUMP" mode as long as the button is held down. When the button is released the system will automatically turn off. If the ignition is in the "ON" position the suspension will return to travel height.

3. If desired for clearing an obstacle, the vehicle may be moved while in the "RAISE" or "DUMP" mode for a short distance at a slow speed. Remember the vehicle will return to travel height when the "RAISE" or "DUMP" button is released and the leveling system is off.

OPERATIONAL CHECK

Review the operator's manual and check that all functions and lights work correctly.

"NOT IN PARK/BRAKE" Check: Set hand/auto park brake. Set the transmission in the recommended position for parking the vehicle. Turn the ignition on. Push the "AIR" button on the touch panel. Release the hand/auto park brake.

CAUTION: THE VEHICLE MAY MOVE FORWARD OR BACKWARD WHEN THE PARK IS RELEASED.

Check that the "NOT IN PARK/BRAKE" light comes ON. Reapply the park brake. The "NOT IN PARK/BRAKE" light should go out.

NOTE: If any checks reveal any problems or if there are other problems or questions, consult a qualified rv repair center, your vehicle or coach manufacturer or HWH Corporation for service or assistance.

SENSING UNIT MAINTENANCE/SERVICE

SENSING UNIT ACCURACY TOLERANCE

The sensing unit has an accuracy tolerance of ± 5.4 inches front to rear and ± 1 inch side to side on a 36 foot vehicle. Typical leveling results will be better.

SENSING UNIT ADJUSTMENT

To adjust the sensing unit, first the vehicle must be level. Either position the vehicle on a level surface or use the leveling system to manually level the vehicle. It is recommended to use the vehicle trim line to determine level. An alternative would be to use a small bubble level. If using a bubble level, the level should be placed on a flat surface close to the mounting location of the control box/sensing unit.

With the vehicle level, if there are no yellow light lit on the Touch Panel, the sensing unit is properly adjusted. If there are yellow LEVEL lights lit on the Touch Panel, manual adjustments to the Sensing Unit are needed. A Phillips screw driver or sockets w/driver or box end wrenches of 7/8, 3/4, 1/2, 5/16 or 1/4 sizes will be needed.

The Sensing Unit is mounted inside the Control Box. The Control Box is mounted to the power unit/valve assembly.

There are four LED's on the Sensing Unit, A,B,C and D. Refer to the drawing below. The Sensing Unit is adjusted by turning the adjustment nut to turn out LED's B and D. The adjustment screw will turn out LED's A and C. If the adjustment nut has to be turned more than 1/2 flat or the adjustment screw has to be turned more than 3/4 turn to turn the LED out, there may be a problem with the Sensing Unit or the mounting of the Control Box. If two LED's are on, it is best to make the B-D adjustments first, then hold the adjustment nut from moving while making the A-C adjustment.

NOTE: If opposing LED's are lit, there is a problem with the Sensing Unit.

If LED (A) is lit: Turn the adjustment screw COUNTER CLOCKWISE until the LED is off.

If LED (C) is lit: Turn the adjustment screw CLOCKWISE until the LED is off.

If LED (B) is lit: Turn the adjustment nut COUNTER CLOCKWISE until the LED is off.

If LED (D) is lit: Turn the adjustment nut CLOCKWISE until the LED is off.

IMPORTANT: When all 4 LED's are off, move the vehicle to an unlevel position so one or two yellow lights are on. Level the vehicle according to the yellow LEVEL lights. Recheck the level. If more adjustment is needed, DO NOT try to adjust the sensing unit until the yellow level lights go out, instead just "tweak" the sensing unit, ignoring the LED's on the sensing unit.

Example: After the initial adjustment and releveling the vehicle, the front is still low. This means the front yellow level light is turning off too soon. Determine which sensing unit light is the front light, A-B-C or D. Move the adjustment for that light very, very, slightly in the OPPOSITE direction that is given in the above instructions for LED's A, B, C, and D. This will allow the front yellow light to stay on slightly longer to bring the front up more. Again, unlevel the vehicle then relevel the vehicle using the yellow level lights on the touch panel. Recheck with a level. Repeat the "tweaking" process until the system levels the vehicle properly.

TOP VIEW - SENSING UNIT

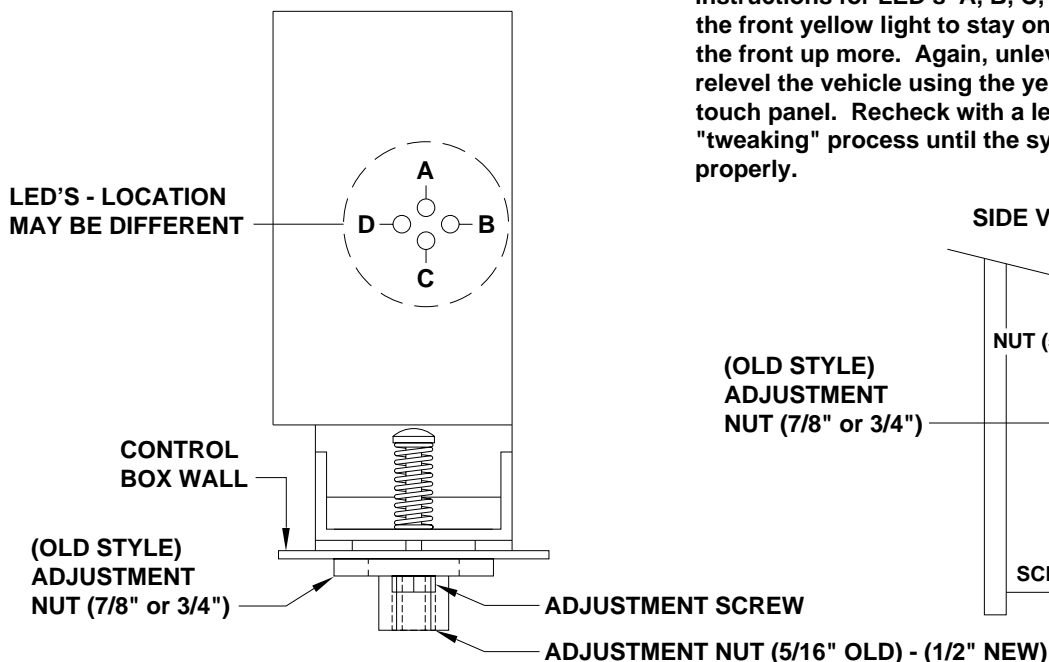

SIDE VIEW - CONTROL BOX

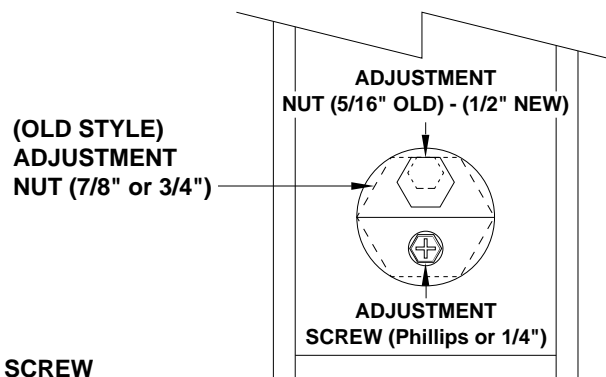

AIR LINE CONNECTION DIAGRAM

FOUR POINT AIR LEVELING WITH TAG AXLE

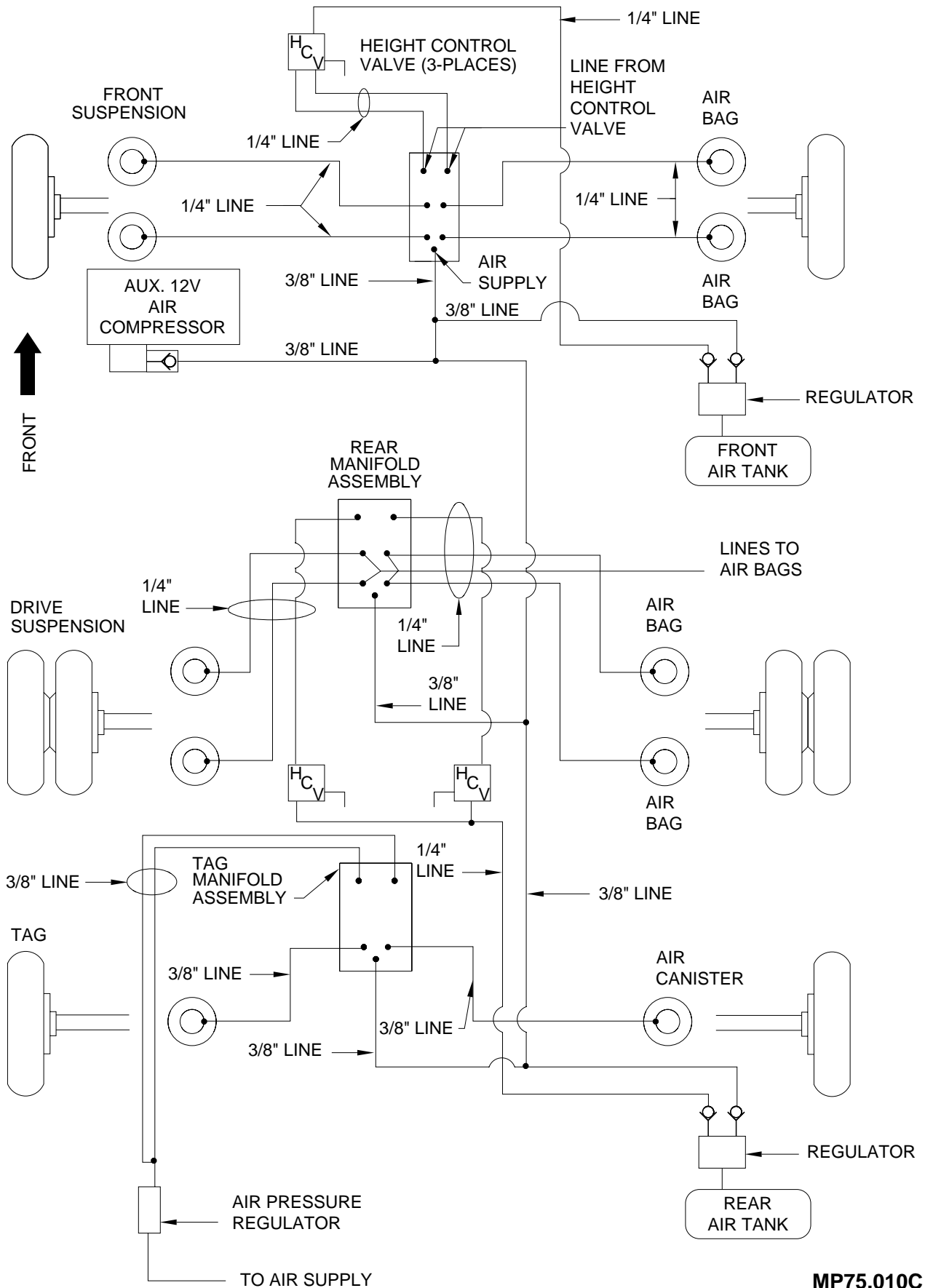

AIR LEVEL SCHEMATIC - MONACO

4-POINT LEVELING WITH AIR COMPRESSOR

PRESSURE SWITCHES FRONT AND REAR DRIVE AXLE

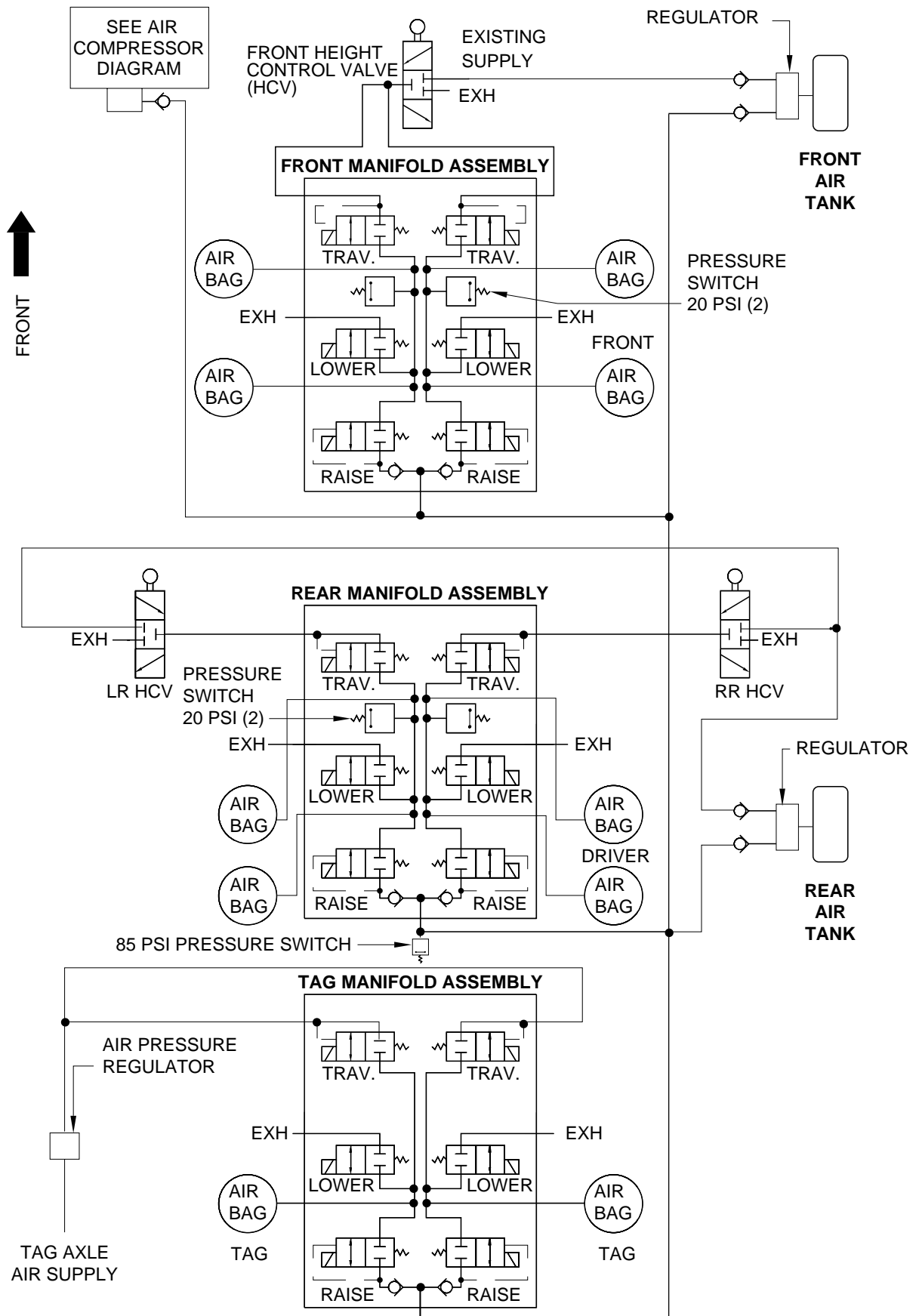

FRONT AIR SOLENOID MANIFOLD CONNECTIONS

6 VALVE WITH TWO PRESSURE SWITCHES

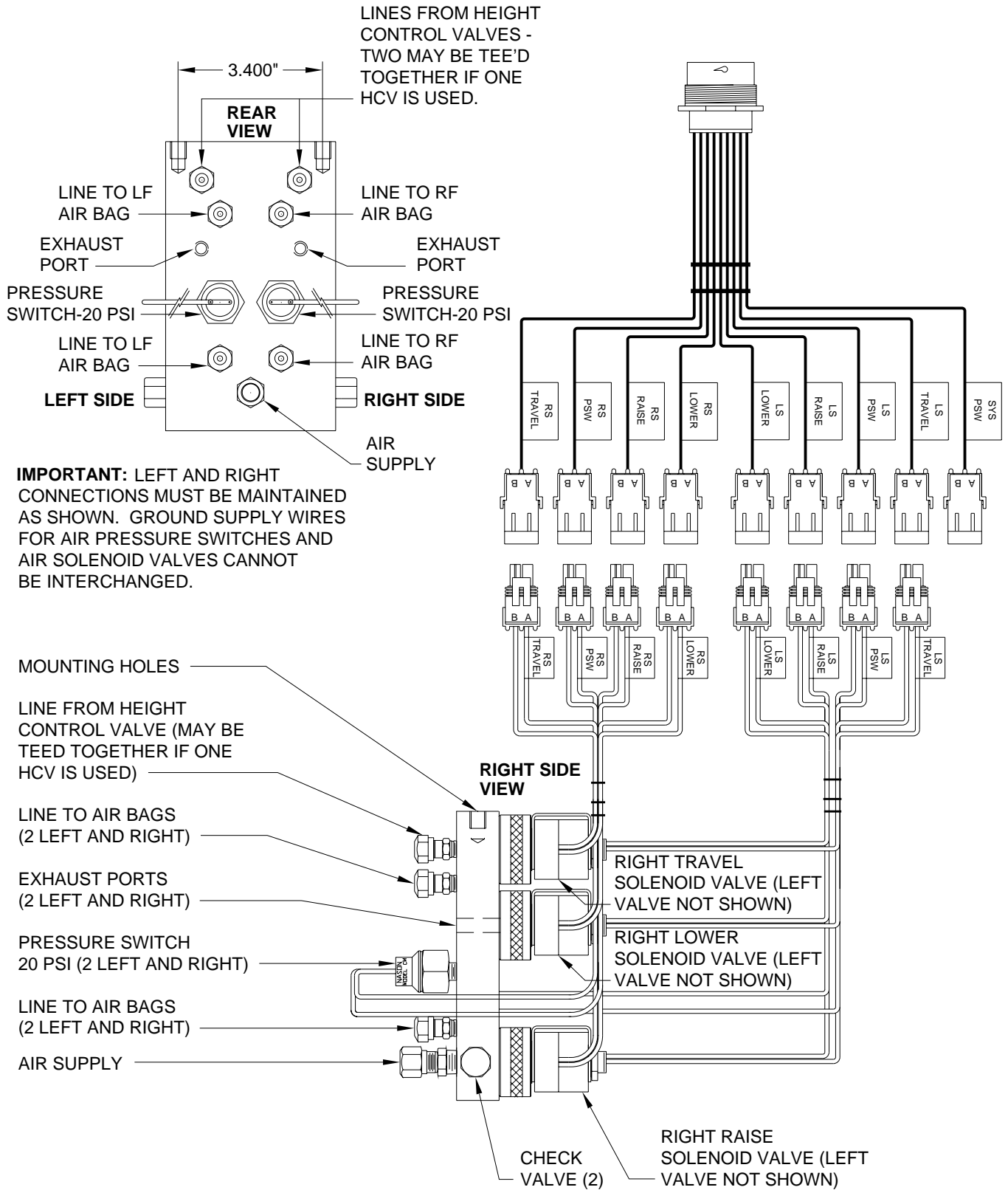

REAR AIR SOLENOID MANIFOLD CONNECTIONS

6 VALVE WITH THREE PRESSURE SWITCHES

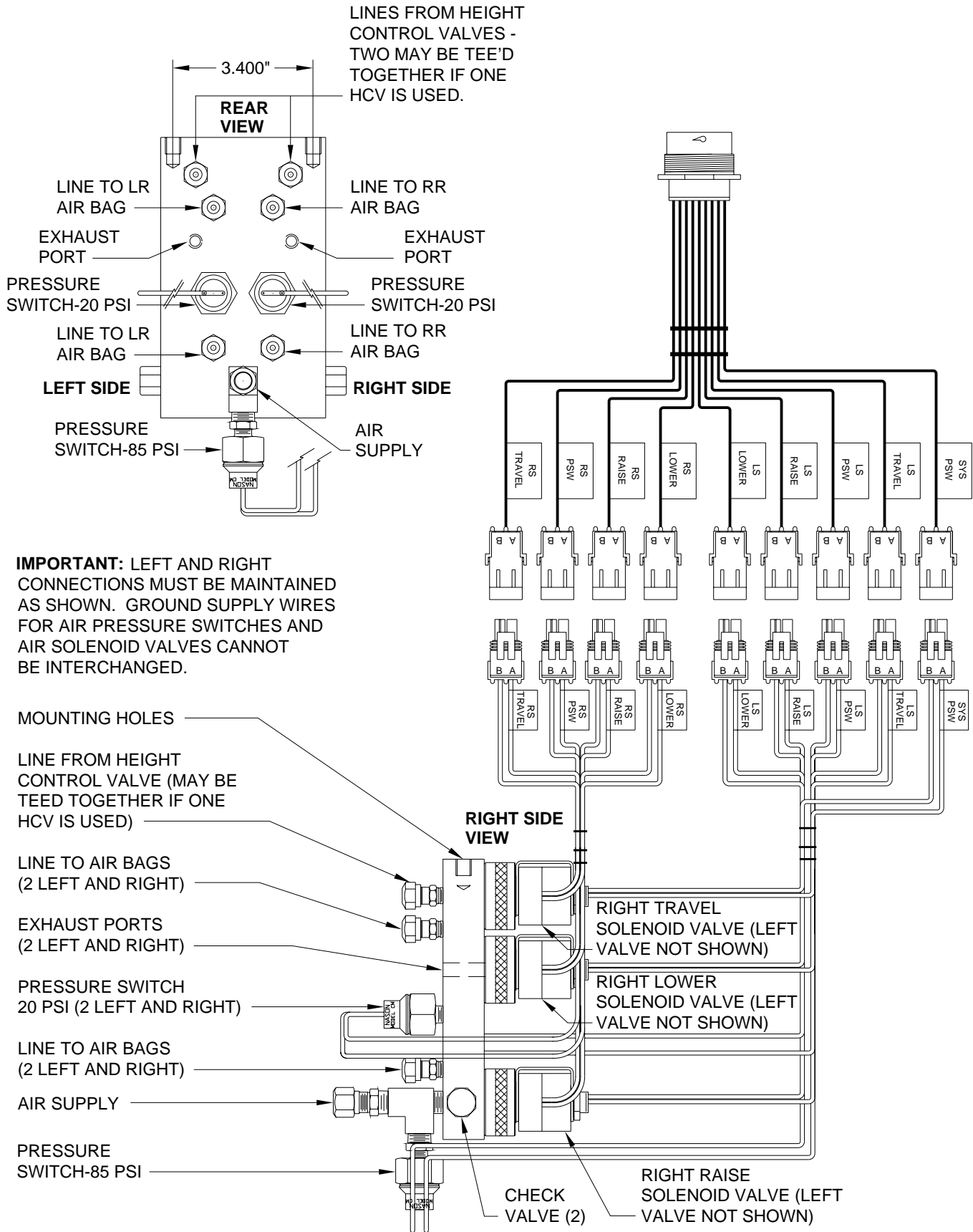

TAG AIR SOLENOID MANIFOLD CONNECTIONS

6 VALVE WITH TWO PRESSURE SWITCHES

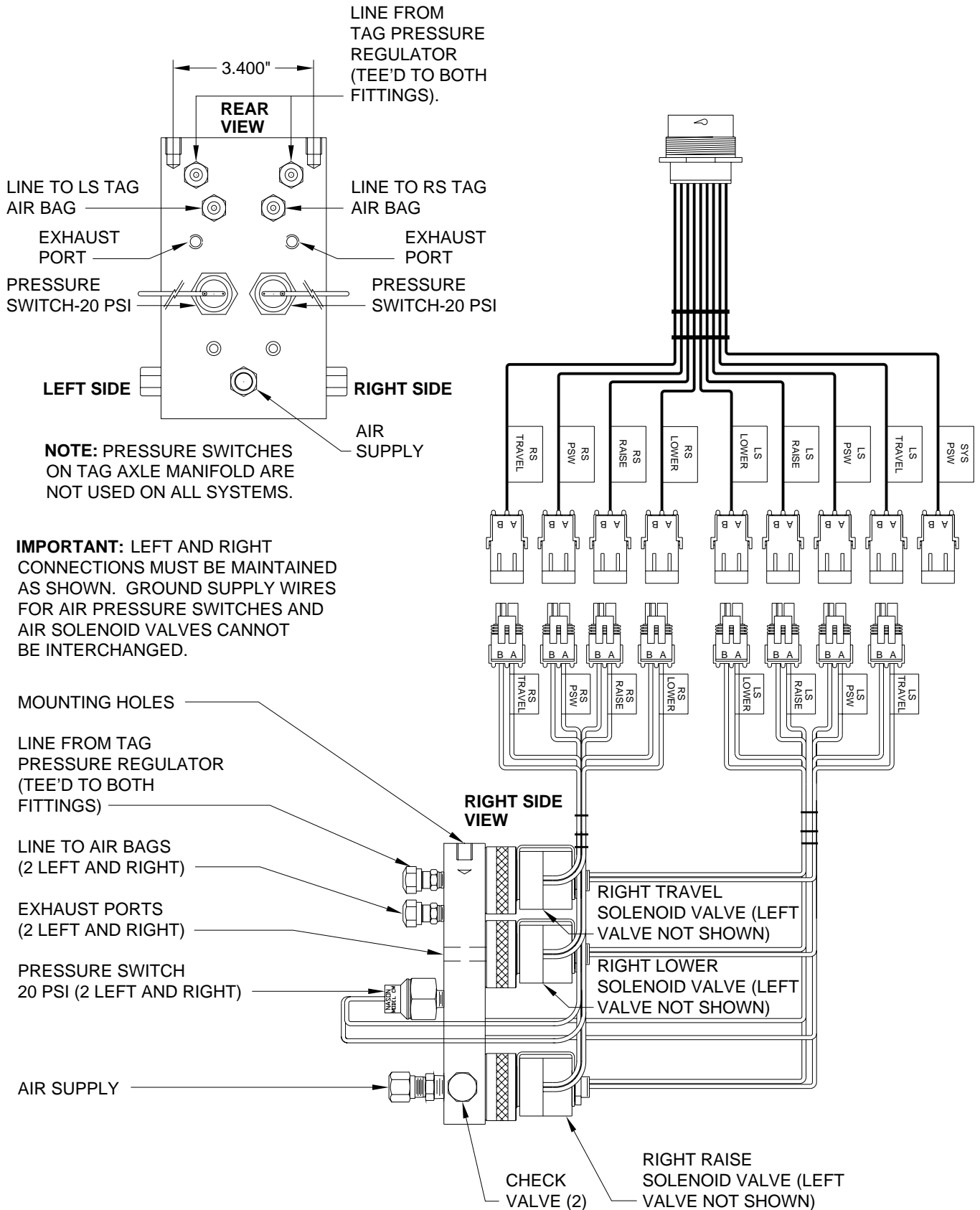

AIR COMPRESSOR DIAGRAM

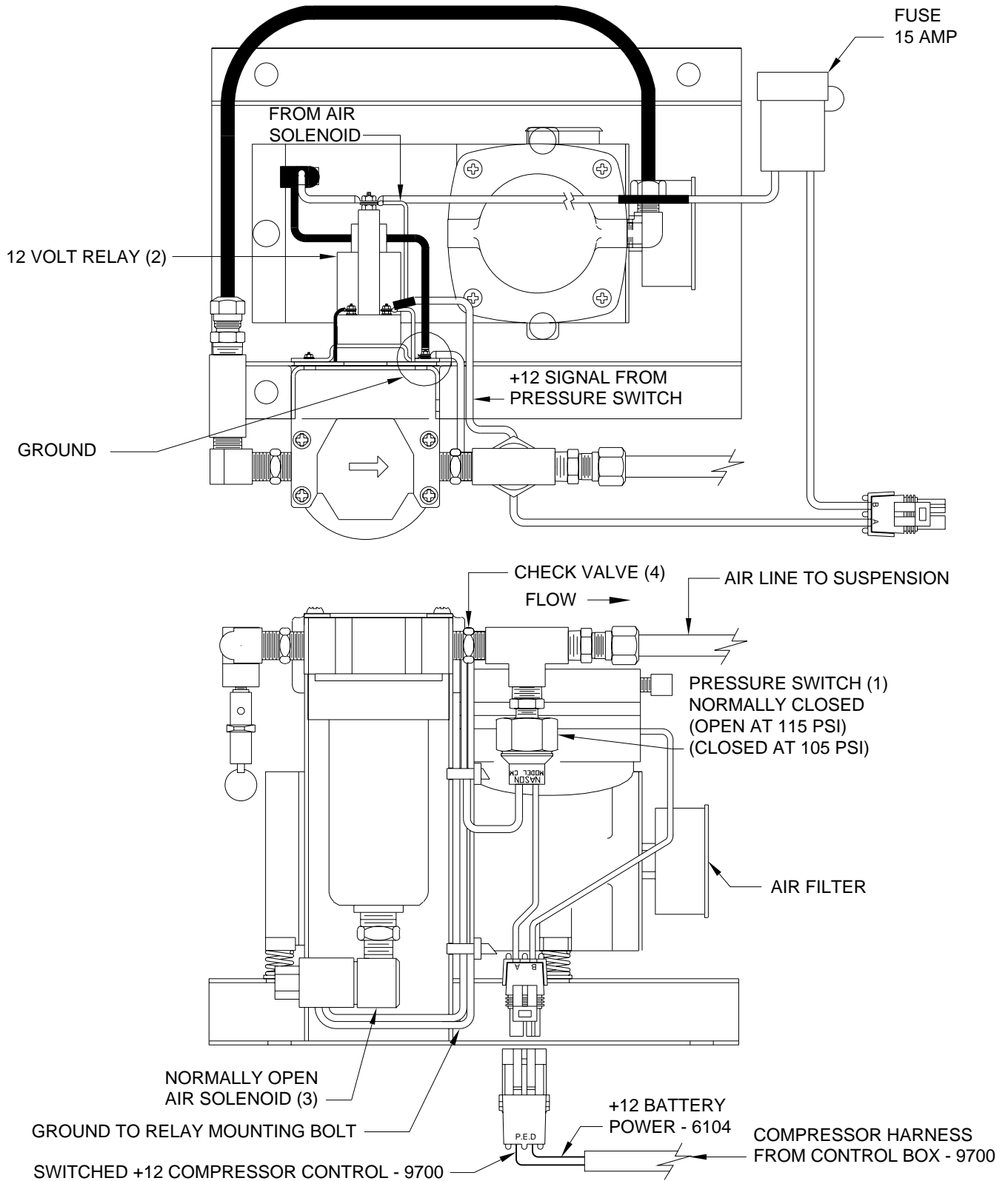

The control box sends a +12 signal to the normally closed pressure switch (1). If the pressure is low, the 12 volt relay (2) will energize and the compressor will run. The normally open air solenoid (3) will close allowing the compressor to build pressure. When the pressure builds to 115 psi the pressure switch will open, stopping the air compressor. The normally open air solenoid (3) will open, allowing internal pressure & moisture to bleed off. The check valve (4) will keep the suspension air from bleeding back to the compressor. As air pressure drops below 105 psi the compressor will start.

ELECTRICAL CONNECTION DIAGRAM

2000 SERIES CAN SYSTEM

AIR LEVELING

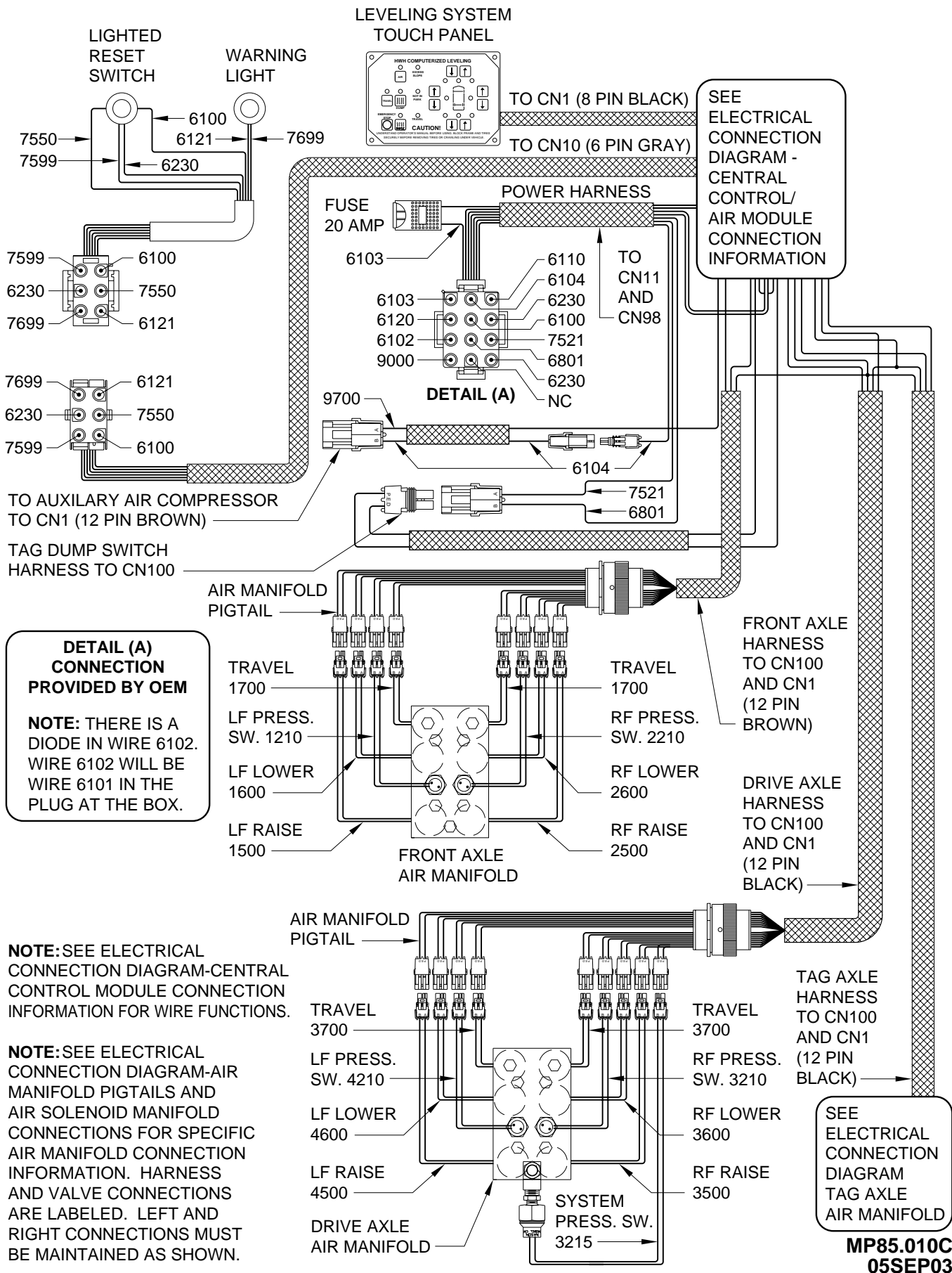

**DETAIL (A)
CONNECTION
PROVIDED BY OEM**

NOTE: THERE IS A DIODE IN WIRE 6102. WIRE 6102 WILL BE WIRE 6101 IN THE PLUG AT THE BOX.

NOTE: SEE ELECTRICAL CONNECTION DIAGRAM-CENTRAL CONTROL MODULE CONNECTION INFORMATION FOR WIRE FUNCTIONS.

NOTE: SEE ELECTRICAL CONNECTION DIAGRAM-AIR MANIFOLD PIGTAILS AND AIR SOLENOID MANIFOLD CONNECTIONS FOR SPECIFIC AIR MANIFOLD CONNECTION INFORMATION. HARNESS AND VALVE CONNECTIONS ARE LABELED. LEFT AND RIGHT CONNECTIONS MUST BE MAINTAINED AS SHOWN.

SEE ELECTRICAL CONNECTION DIAGRAM TAG AXLE AIR MANIFOLD

ELECTRICAL CONNECTION DIAGRAM

TAG AXLE AIR MANIFOLD

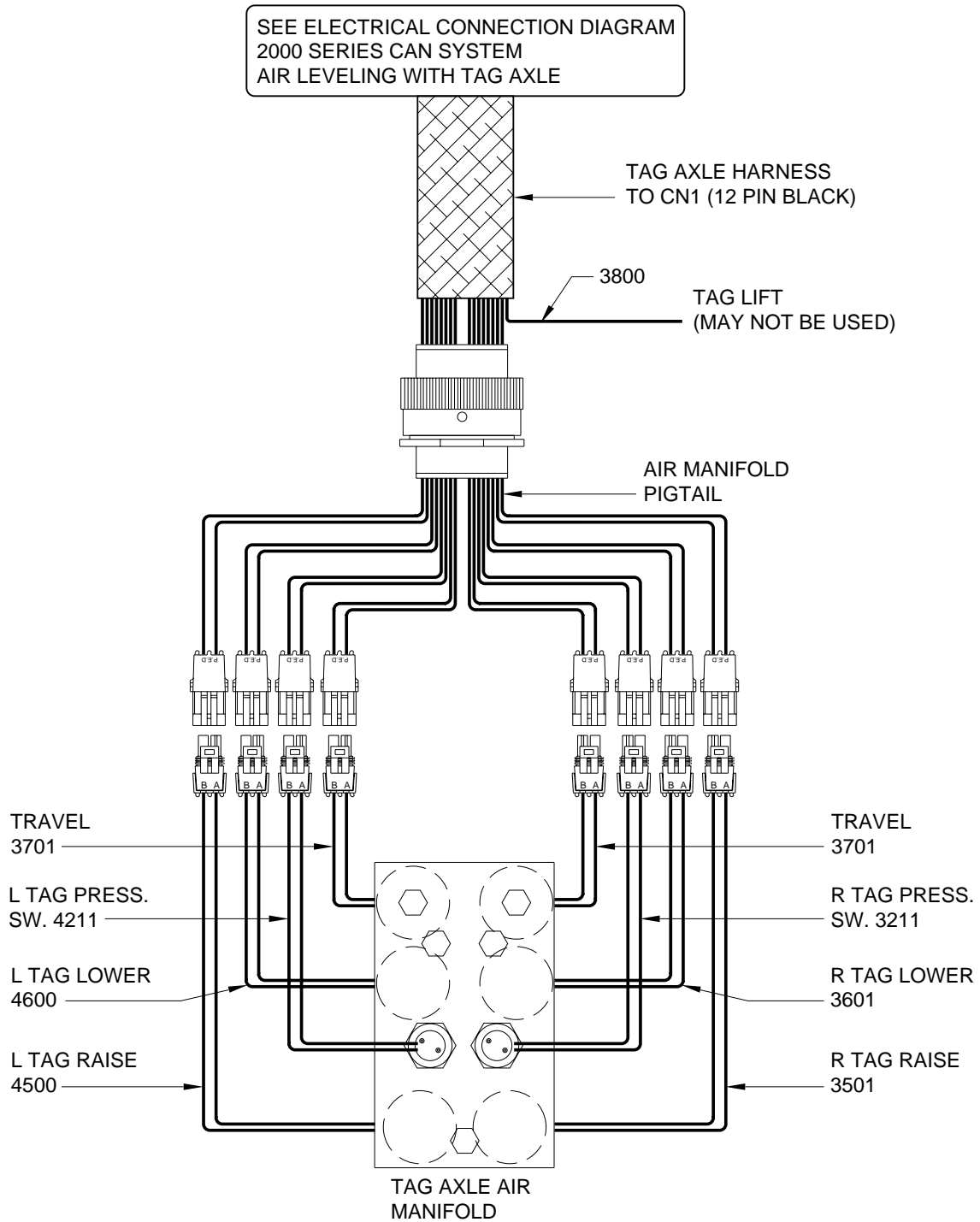

NOTE: HARNESS AND VALVE CONNECTIONS ARE LABELED. SEE TAG AIR SOLENOID MANIFOLD CONNECTIONS FOR SPECIFIC CONNECTION INFORMATION LEFT AND RIGHT CONNECTIONS MUST BE MAINTAINED AS SHOWN.

ELECTRICAL CONNECTION DIAGRAM

CENTRAL CONTROL / AIR MODULE

PAGE 1 OF 2

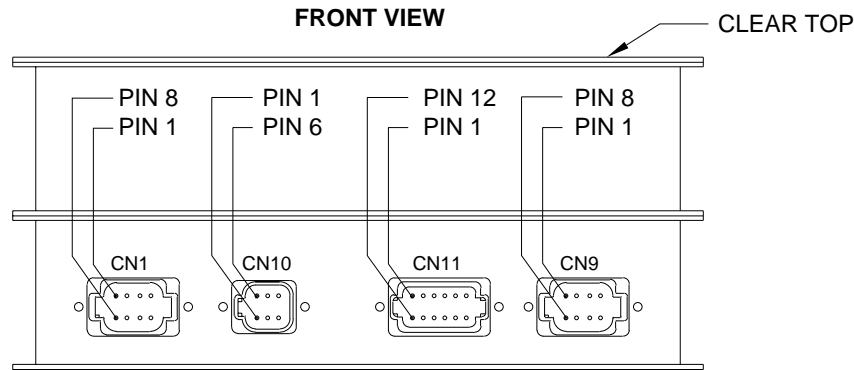

PIN #	WIRE COLOR	WIRE NUMBER	WIRE DESCRIPTION AND FUNCTION
CN1			8 PIN BLACK CONNECTOR
1	-	-	NO CONNECTION
2	-	-	NO CONNECTION
3	RED	6800	+12 SWITCHED BATTERY TO TOUCH PANEL
4	WHITE	6230	GRND TO TOUCH PANEL
5	-	-	SHIELD WIRE FOR CAN CABLE
6	-	-	NO CONNECTION
7	GREEN	-	CAN DATA LINE LOW-DO NOT MODIFY
8	YELLOW	-	CAN DATA LINE HIGH-DO NOT MODIFY
CN10			6 PIN GRAY CONNECTOR
1	BLACK	7599	RESET SWITCH LIGHT CONTROL-SWITCHED +12
2	RED	6100	RESET SWITCH SUPPLY +12
3	BLACK	7550	RESET SWITCH OUTPUT +12
4	RED	6121	WARNING LIGHT SUPPLY +12
5	WHITE	6230	RESET SWITCH LIGHT GROUND
6	BLACK	7699	WARNING LIGHT CONTROL - SWITCHED GROUND
CN11			12 PIN GRAY CONNECTOR
1	RED	6110	SWITCHED +12 FROM IGNITION
2	-	-	NO CONNECTION
3	-	-	NO CONNECTION
4	-	-	NO CONNECTION
5	RED	6120	SWITCHED +12 FROM ACCESSORY
6	RED	6100	HOUSE BATTERY +12
7	WHITE	6230	GROUND FOR PROCESSOR
8	-	-	NO CONNECTION
9	-	-	NO CONNECTION
10	-	-	NO CONNECTION
11	BLACK	9000	FROM PARK BRAKE SWITCH - SWITCHED GROUND
12	RED	6101	ENGINE BATTERY +12
CN9			8 PIN GREEN CONNECTOR
1 THRU 8	-	-	NO CONNECTION

ELECTRICAL CONNECTION DIAGRAM

CENTRAL CONTROL / AIR MODULE

PAGE 2 OF 2

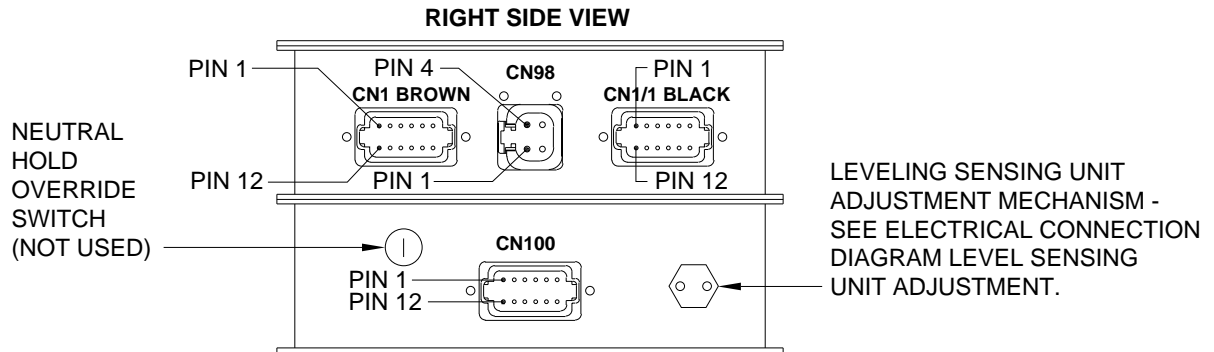

PIN #	WIRE COLOR	WIRE NUMBER	WIRE DESCRIPTION AND FUNCTION
CN1 (12 PIN BROWN)			12 PIN BROWN CONNECTOR
1			NO CONNECTION
2	BLACK	1500	LEFT FRONT RAISE AIR VALVE CONTROL - SWITCHED +12
3	BLACK	1600	LEFT FRONT LOWER AIR VALVE CONTROL - SWITCHED +12
4	BLACK	2500	RIGHT FRONT RAISE AIR VALVE CONTROL - SWITCHED +12
5	BLACK	2600	RIGHT FRONT LOWER AIR VALVE CONTROL - SWITCHED +12
6	BLACK	9700	AUXILARY AIR COMPRESSOR CONTROL - SWITCHED +12
7			NO CONNECTION
8	BLACK	1700	FRONT AIR MANIFOLD TRAVEL VALVES CONTROL - SWITCHED +12
9			NO CONNECTION
10			NO CONNECTION
11	WHITE	6254	GROUND FOR AIR SOLENOID VALVES
12			NO CONNECTION
CN98			4 PIN GRAY CONNECTOR
1	BLACK	6800	SWITCHED +12 BATTERY
2	BLACK	6800	SWITCHED +12 BATTERY
3	WHITE	6230	GROUND FROM GROUND STUD - FOR SOLENOID VALVES
4	WHITE	6230	GROUND FROM GROUND STUD - FOR SOLENOID VALVES
CN1/1 (12 PIN BLACK)			12 PIN BLACK CONNECTOR
1	BLACK	3800	TAG LIFT - SWITCHED +12
2	BLACK	4500	LEFT REAR RAISE AIR VALVE CONTROL - SWITCHED +12
3	BLACK	4600	LEFT REAR LOWER AIR VALVE CONTROL - SWITCHED +12
4	BLACK	3500	RIGHT REAR RAISE AIR VALVE CONTROL - SWITCHED +12
5	BLACK	3600	RIGHT REAR LOWER AIR VALVE CONTROL - SWITCHED +12
6			NO CONNECTION
7	BLACK	3701	TAG AIR MANIFOLD TRAVEL VALVES CONTROL - SWITCHED +12
8	BLACK	3700	REAR AIR MANIFOLD TRAVEL VALVES CONTROL - SWITCHED +12
9	BLACK	3601	RIGHT TAG LOWER AIR VALVE CONTROL - SWITCHED +12
10	BLACK	4601	LEFT TAG LOWER AIR VALVE CONTROL - SWITCHED +12
11	WHITE	6258	GROUND SUPPLY FOR REAR AND TAG AIR SOLENOID VALVES
12			NO CONNECTION
CN100			12 PIN GRAY CONNECTOR
1			NO CONNECTION
2	BLACK	1210	LEFT FRONT PRESSURE SWITCH INPUT - SWITCHED GROUND
3	BLACK	2210	RIGHT FRONT PRESSURE SWITCH INPUT - SWITCHED GROUND
4	BLACK	3210	RIGHT REAR PRESSURE SWITCH INPUT - SWITCHED GROUND
5	BLACK	4210	LEFT REAR PRESSURE SWITCH INPUT - SWITCHED GROUND
6	WHITE	6231	GROUND SUPPLY FOR ALL AIR MANIFOLD PRESSURE SWITCHES
7	BLACK	6800	SWITCHED +12 SUPPLY TO TAG DUMP SWITCH
8	BLACK	3215	AIR SYSTEM PRESSURE SWITCH - SWITCHED GROUND
9	BLACK	3211	RIGHT TAG PRESSURE SWITCH INPUT - SWITCHED GROUND
10	BLACK	4211	LEFT TAG PRESSURE SWITCH INPUT - SWITCHED GROUND
11	BLACK	7521	SWITCHED +12 FROM TAG DUMP SWITCH
12			NO CONNECTION

**ELECTRICAL CONNECTION DIAGRAM
LED - FUSE LOCATION AND DESCRIPTION
CENTRAL CONTROL / AIR MODULE
PAGE 1A OF 1 A-B**

CENTRAL CONTROL MOTHER BOARD

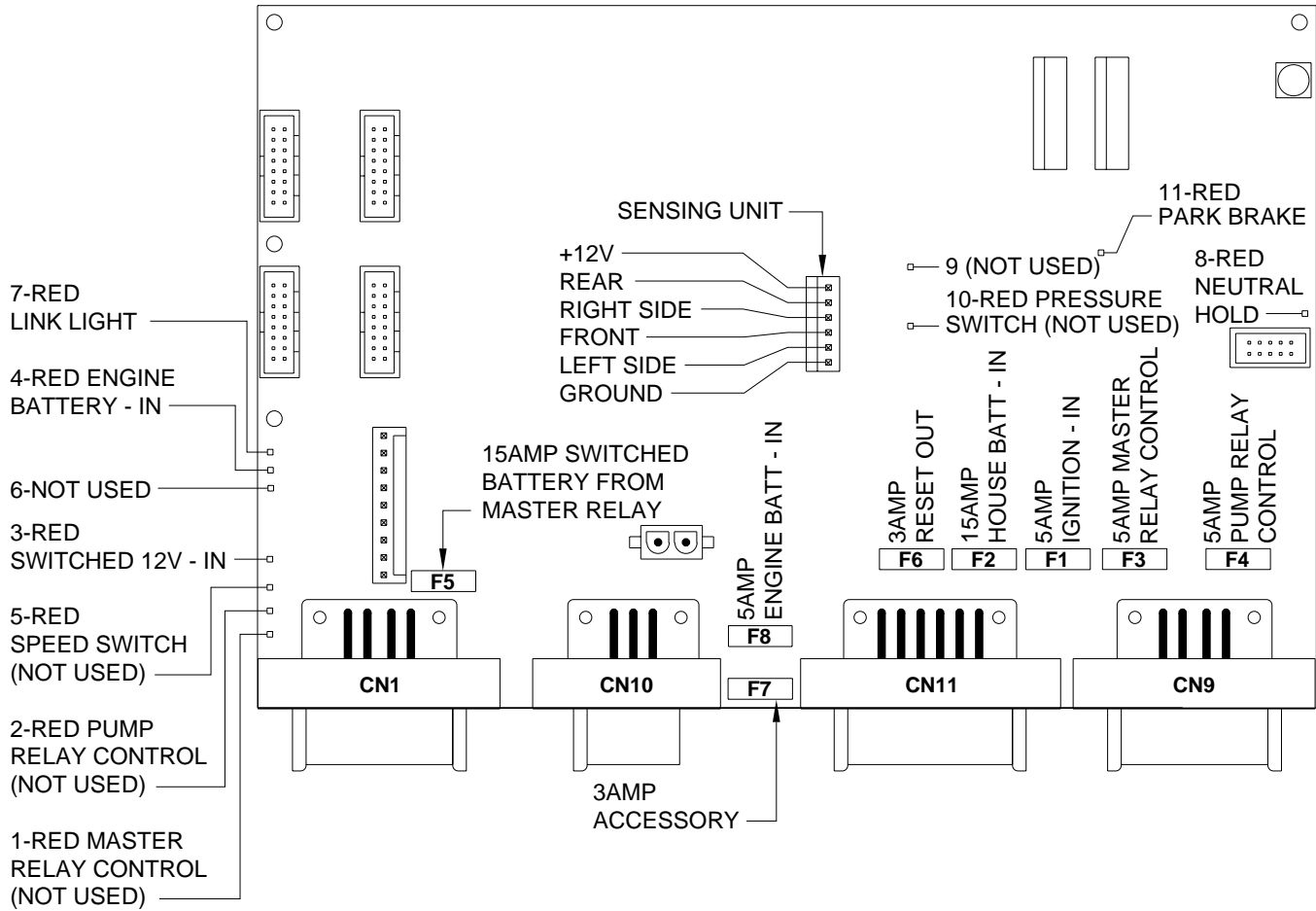

LED	DESCRIPTION	CN AND PIN	FUSE DESCRIPTION
1-RED	MASTER RELAY CONTROL (NOT USED)	CN 9 - PIN 1	F1 - 5AMP IGNITION - IN
2-RED	PUMP RELAY CONTROL (NOT USED)	CN 9 - PIN 4	F2 - 15AMP HOUSE BATTERY - IN
3-RED	SWITCHED 12V FROM MASTER RELAY	CN 1 - PIN 3	F3 - 5AMP MASTER RELAY CONTROL
4-RED	ENGINE BATTERY - IN	CN 11 - PIN 12	F4 - 5AMP PUMP RELAY CONTROL
5-RED	SPEED SWITCH (NOT USED)	CN 9 - PIN 5	F5 - 15AMP SWITCHED BATTERY - IN
6-NOT USED	NOT USED	NOT USED	F6 - 3AMP RESET OUT
7-RED	LINK LIGHT	NOT USED	F7 - 3AMP ACCESSORY - IN
8-RED	NEUTRAL HOLD	CN 11 - PIN 8 & 9	F8 - 5AMP ENGINE BATTERY - IN
9-NOT USED	NOT USED	NOT USED	
10-RED	3000 LBS PRESS SWITCH - ON (NOT USED)	CN 9 - PIN 2	
11-RED	PARK PRAKE - ON	CN 11 - PIN 11	

ALSO SEE MP85.048C FOR DIFFERENT FUSE ARRANGEMENT.

NOTE: FOR DETAILED INPUT / OUTPUT INFORMATION ABOUT PIN CONNECTIONS SEE ELECTRICAL CONNECTION DIAGRAM - CENTRAL CONTROL / AIR MODULE CONNECTION INFORMATION - PAGE 1 OF 2

**ELECTRICAL CONNECTION DIAGRAM
LED - FUSE LOCATION AND DESCRIPTION
CENTRAL CONTROL MODULE (BOTTOM RING)
PAGE 1B OF 1 A-B**

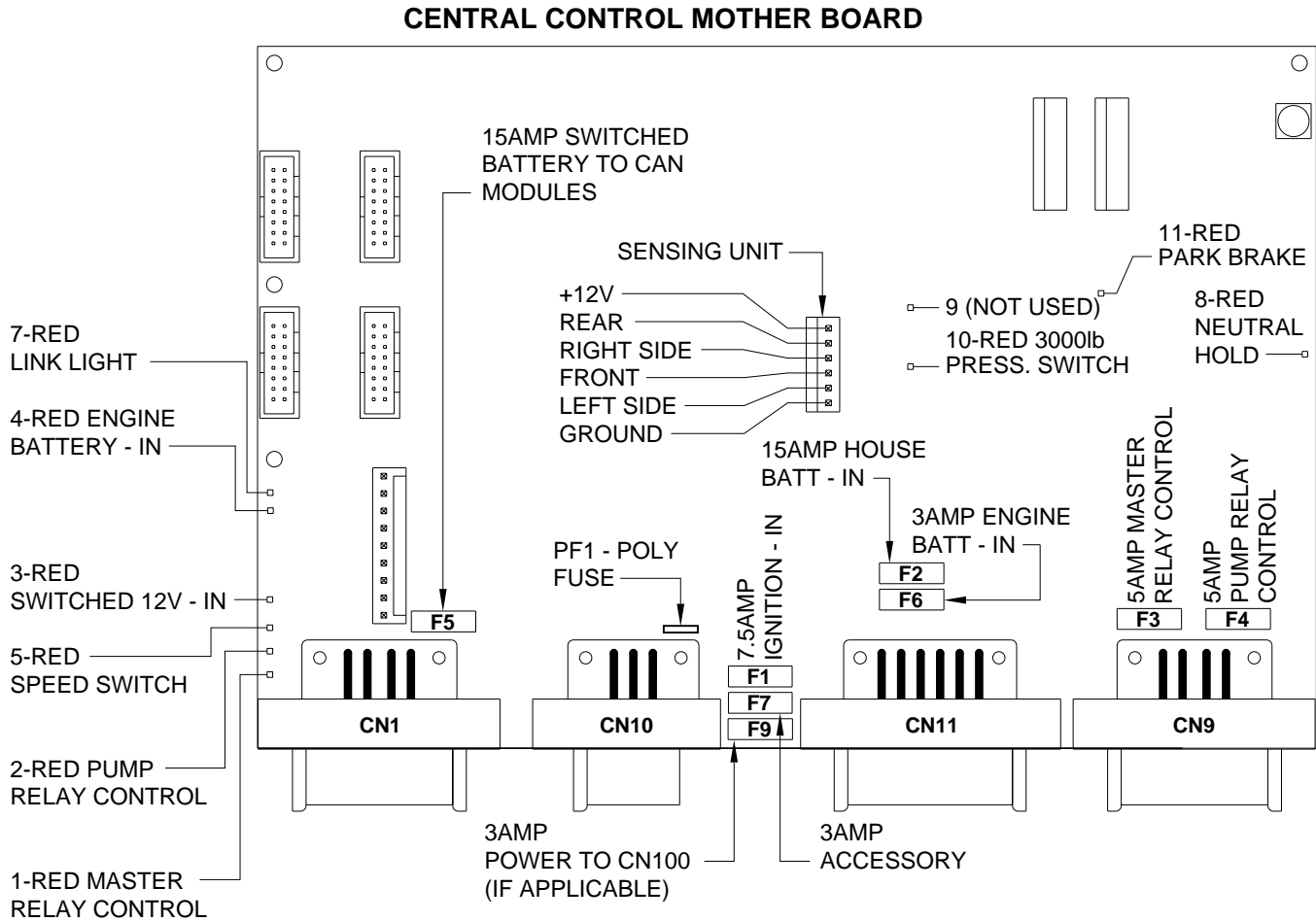

LED	DESCRIPTION	CN AND PIN	FUSE DESCRIPTION
1-RED	MASTER RELAY CONTROL (NOT USED)	CN 9 - PIN 1	PF1 - POLY FUSE - POWER TO MASTER WARNING LIGHT AND RESET SWITCH F1 - 7.5AMP IGNITION - IN F2 - 15AMP HOUSE BATTERY - IN F3 - 5AMP MASTER RELAY CONTROL F4 - 5AMP PUMP RELAY CONTROL F5 - 15AMP SWITCHED BATTERY - IN F6 - 3AMP RESET OUT F7 - 3AMP ACCESSORY - IN F9 - 3AMP POWER TO CN100 (IF APPLICABLE)
2-RED	PUMP RELAY CONTROL (NOT USED)	CN 9 - PIN 4	
3-RED	SWITCHED 12V FROM MASTER RELAY	CN 1 - PIN 3	
4-RED	ENGINE BATTERY - IN	CN 11 - PIN 12	
5-RED	SPEED SWITCH*	CN 9 - PIN 5	
7-RED	LINK LIGHT	CN 1 - PIN 7 & 8	
8-RED	NEUTRAL HOLD**	CN 11 - PIN 8 & 9	
9-NOT USED	NOT USED	NOT USED	
10-RED	3000 LBS PRESS SWITCH - ON	CN 9 - PIN 2	
11-RED	PARK PRAKE - ON	CN 11 - PIN 11	

NOTE: FOR DETAILED INPUT / OUTPUT INFORMATION ABOUT PIN CONNECTIONS SEE ELECTRICAL CONNECTION DIAGRAM - CENTRAL CONTROL / AIR MODULE CONNECTION INFORMATION - PAGE 1 OF 2

* LED 5 INDICATES A +12 SIGNAL FROM THE SPEED SWITCH - IGNITION ON COACH SPEED LESS THAN 10 MPH
 ** LED 8 INDICATES TRANSMISSION IS DISABLED WHEN LIT.

ELECTRICAL CONNECTION DIAGRAM

LED - FUSE LOCATION AND DESCRIPTION

CENTRAL CONTROL / AIR MODULE

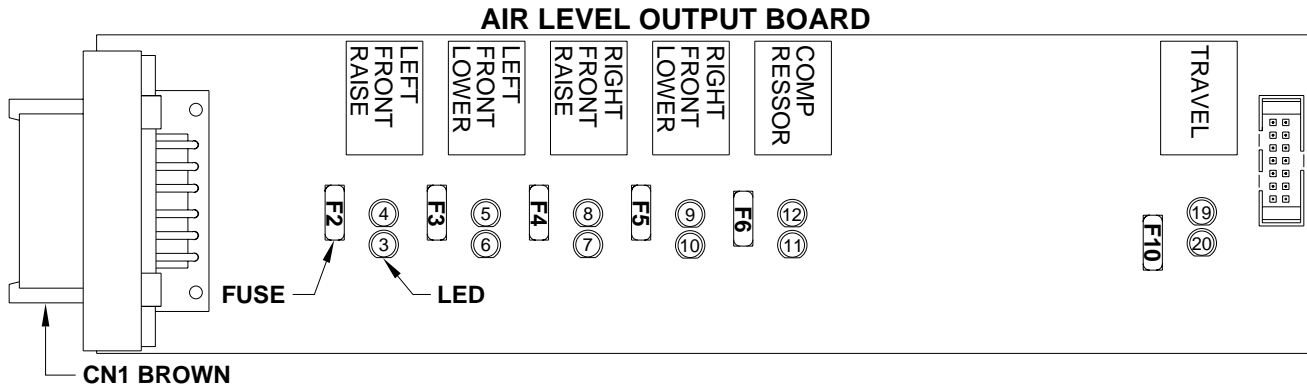

LED	RELAY DESCRIPTION	FUSE	BROWN
3-RED	LEFT FRONT RAISE	F2-5 AMP	PIN 2
4-YELLOW	LEFT FRONT RAISE		
5-YELLOW	LEFT FRONT LOWER	F3-5 AMP	PIN 3
6-RED	LEFT FRONT LOWER		
7-RED	RIGHT FRONT RAISE	F4-5 AMP	PIN 4
8-YELLOW	RIGHT FRONT RAISE		
9-YELLOW	RIGHT FRONT LOWER	F5-5 AMP	PIN 5
10-RED	RIGHT FRONT LOWER		
11-RED	COMPRESSOR	F6-5 AMP	PIN 6
12-YELLOW	COMPRESSOR		
19-YELLOW	TRAVEL	F10-7.5 AMP	PIN 8
20-RED	TRAVEL		

NOTE: THE TRAVEL RELAY IS WIRED AS A NORMALLY CLOSED RELAY. WHEN THE YELLOW LED (19) IS ON THE RELAY CONTACTS WILL OPEN. THE RED LED (20) WILL NOT BE ON. THE RED LED WILL BE ON IF THE LEVELING SYSTEM IS IN THE TRAVEL MODE AND THE IGNITION IS ON.

NOTE: FOR DETAILED INPUT / OUTPUT INFORMATION ABOUT PIN CONNECTIONS SEE ELECTRICAL CONNECTION DIAGRAM - CENTRAL CONTROL / AIR MODULE CONNECTION INFORMATION.

NOTE: A LIT YELLOW LED INDICATES THERE IS A GROUND SIGNAL TO TURN THE CORRESPONDING RELAY ON.

A LIT RED LED INDICATES THERE IS VOLTAGE ON IT'S CORRESPONDING PIN.

IF A YELLOW LED IS LIT AND THE CORRESPONDING RED LED IS OFF, EITHER IT'S FUSE IS BLOWN OR THE RELAY IS BAD.

IF THE YELLOW LEDS ARE WORKING BUT NO RED LED IS COMING ON THERE IS A PROBLEM WITH INPUT VOLTAGE IN THE 4-PIN CONNECTOR ON THE MIDDLE RING.

IF A YELLOW LED IS NOT LIT, THIS INDICATES A PROBLEM WITH A MODULE.

ELECTRICAL CONNECTION DIAGRAM

LED - FUSE LOCATION AND DESCRIPTION

CENTRAL CONTROL / AIRMODULE

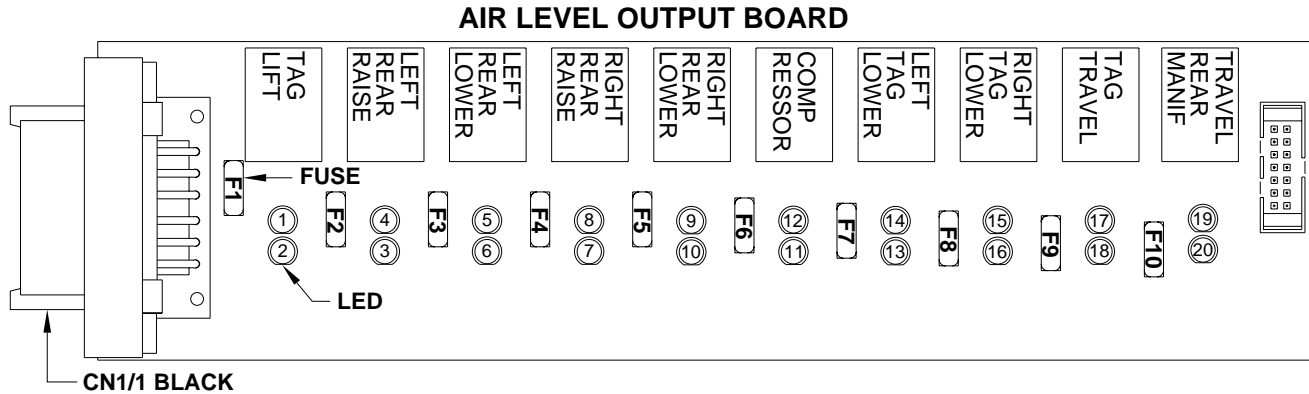

LED	RELAY DESCRIPTION	FUSE	BLACK
1-YELLOW	TAG LIFT		
2-RED	TAG LIFT	F1-5 AMP	PIN 1
3-RED	LEFT REAR RAISE	F2-5 AMP	PIN 2
4-YELLOW	LEFT REAR RAISE		
5-YELLOW	LEFT REAR LOWER		
6-RED	LEFT REAR LOWER	F3-5 AMP	PIN 3
7-RED	RIGHT REAR RAISE	F4-5 AMP	PIN 4
8-YELLOW	RIGHT REAR RAISE		
9-YELLOW	RIGHT REAR LOWER		
10-RED	RIGHT REAR LOWER	F5-5 AMP	PIN 5
11-RED	COMPRESSOR	F6-5 AMP	NC
12-YELLOW	COMPRESSOR		
13-RED	LEFT TAG LOWER	F7-5 AMP	PIN 10
14-YELLOW	LEFT TAG LOWER		
15-YELLOW	RIGHT TAG LOWER		
16-RED	RIGHT TAG LOWER	F8-5 AMP	PIN 9
17-YELLOW	TAG TRAVEL		
18-RED	TAG TRAVEL	F9-3 AMP	PIN 7
19-YELLOW	TRAVEL - REAR MANIFOLD		
20-RED	TRAVEL - REAR MANIFOLD	F10-3 AMP	PIN 8

NOTE: FOR DETAILED INPUT / OUTPUT INFORMATION ABOUT PIN CONNECTIONS SEE ELECTRICAL CONNECTION DIAGRAM - CENTRAL CONTROL / AIR MODULE CONNECTION INFORMATION.

NOTE: A LIT YELLOW LED INDICATES THERE IS A GROUND SIGNAL TO TURN THE CORRESPONDING RELAY ON.

A LIT RED LED INDICATES THERE IS VOLTAGE ON IT'S CORRESPONDING CN1 PIN.

IF A YELLOW LED IS LIT AND THE CORRESPONDING RED LED IS OFF, EITHER IT'S FUSE IS BLOWN OR THE RELAY IS BAD.

IF THE YELLOW LEDS ARE WORKING BUT NO RED LED IS COMING ON THERE IS A PROBLEM WITH INPUT VOLTAGE IN THE 4-PIN CONNECTOR ON THE TOP RING.

IF A YELLOW LED IS NOT LIT, THIS INDICATES A PROBLEM WITH A MODULE.

NOTE: THE TWO TRAVEL RELAYS ARE WIRED AS NORMALLY CLOSED RELAYS. WHEN THE YELLOW LED (19) IS ON THE RELAY CONTACTS WILL OPEN. THE RED LED (20) WILL NOT BE ON. THE RED LED WILL BE ON IF THE LEVELING SYSTEM IS IN THE TRAVEL MODE AND THE IGNITION IS ON.