

Specifications

The HWH® SpaceMaker® : Dual Cylinder "Level Out Floor" Room Extension (With Guided Tracks and HWH Synchronizing Cylinder)

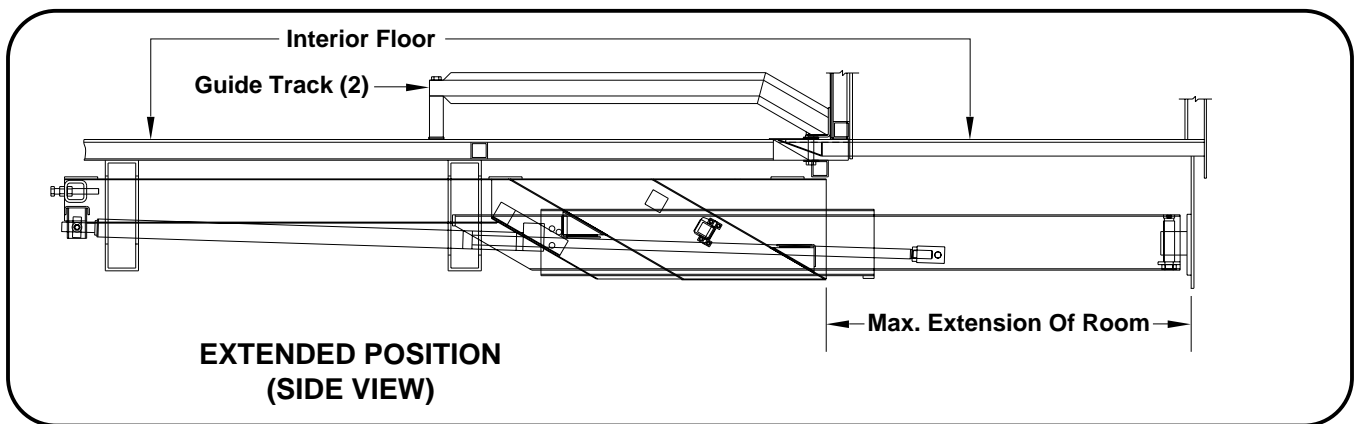
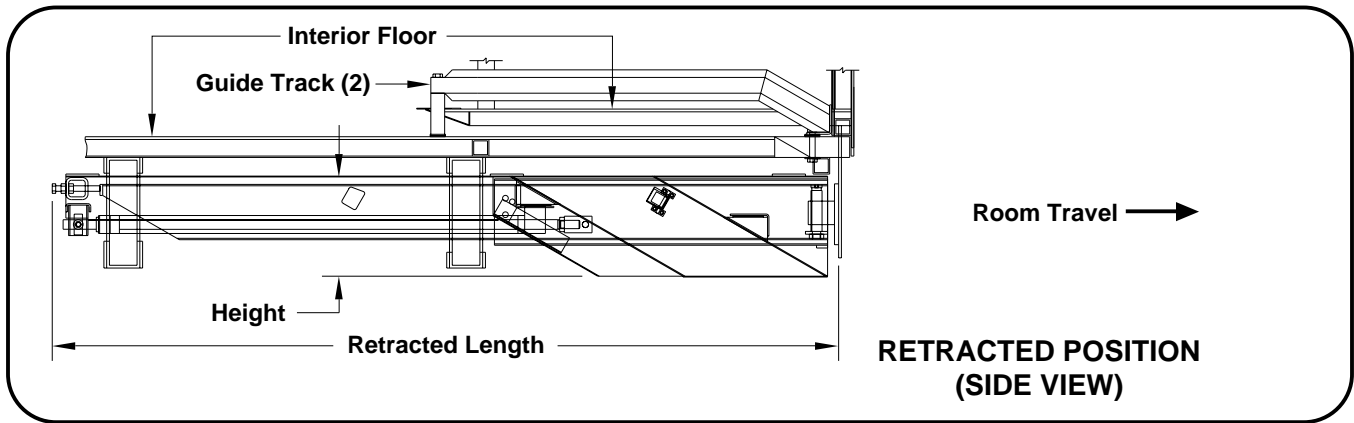

NOTE: SPECIFICATIONS VARY FOR DIFFERENT MODELS.

SPECIFICATIONS FOR SHOWN MODEL	
WEIGHTS (lbs.)	
Mechanism Assembly (2 Guide Tracks)	18.00
Mechanism Assembly (2 Rails)	208.00
Synchronizing Cylinder	15.50
Pump *	14.20
Gross Weight *	255.70
DIMENSIONS (in.)	
Width (Each Guide Track)	1.50
Height (Each Guide Track)	6.00
Width (Each Slide Rail)	8.00
Height (Each Slide Rail)	9.40
Length (Retracted)	72.00
Max. Extension of Room	35.00
LOAD (lbs.)	1,500.00
FORCE of CYLINDER (lbs.)	
Max. Extending	2,100.00
Max. Retracting	2,100.00
PRIMARY APPLICATION	
Any Suitable Room	Below Floor

* If coach is equipped with an HWH Leveling System, pump is included.