



OPERATOR'S MANUAL

HWH COMPUTER-CONTROLLED LEVELING SYSTEM 2000 SERIES

FEATURING:

*Touch Panel Leveling Control
Air Leveling (With Tag Axle Lift)
Multiple Room Extensions (With Air Seals)
Generator Slide*

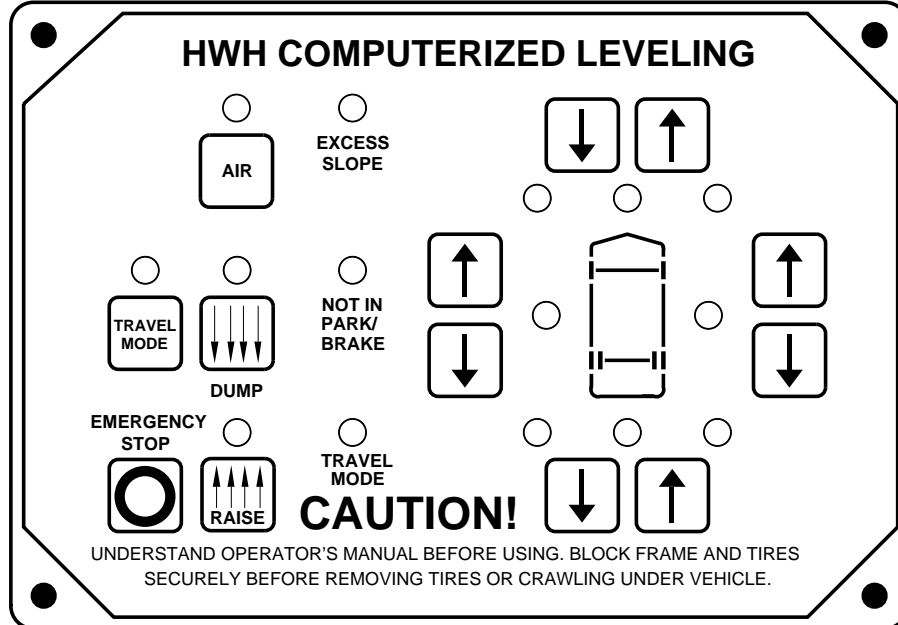

HWH CORPORATION

(On I-80, Exit 267 South)

2096 Moscow Road | Moscow, Iowa 52760

Ph: 800/321-3494 (or) 563/724-3396 | Fax: 563/724-3408

www.hwh.com

OPERATOR'S MANUAL

CAUTION !

READ THE ENTIRE OPERATOR'S MANUAL BEFORE OPERATING.

BLOCK FRAME AND TIRES SECURELY BEFORE CRAWLING UNDER VEHICLE. DO NOT USE LEVELING JACKS OR AIR SUSPENSION TO SUPPORT VEHICLE WHILE UNDER VEHICLE OR CHANGING TIRES. VEHICLE MAY DROP AND/OR MOVE FORWARD OR BACKWARD WITHOUT WARNING CAUSING INJURY OR DEATH.

KEEP ALL PEOPLE CLEAR OF VEHICLE WHILE LEVELING SYSTEM AND ROOM EXTENSION ARE BEING OPERATED.

NEVER PLACE HANDS OR OTHER PARTS OF THE BODY NEAR HYDRAULIC LEAKS. OIL MAY PENETRATE SKIN CAUSING INJURY OR DEATH.

DO NOT OPERATE THE LEVELING SYSTEM OR USE THE DUMP OR RAISE BUTTONS IF THE VEHICLE IS MOVING IN EXCESS OF 5 MPH.

WEAR SAFETY GLASSES WHEN INSPECTING OR SERVICING THE SYSTEM TO PROTECT EYES FROM DIRT, METAL CHIPS, OIL LEAKS, ETC. FOLLOW ALL OTHER APPLICABLE SHOP SAFETY PRACTICES.

IMPORTANT: IF COACH IS EQUIPPED WITH A ROOM EXTENSION, READ ROOM EXTENSION SECTION BEFORE OPERATING LEVELING SYSTEM.

HOW TO OBTAIN WARRANTY SERVICE

THIS IS NOT TO BE INTERPRETED AS A STATEMENT OF WARRANTY

HWH CORPORATION strives to maintain the highest level of customer satisfaction. Therefore, if you discover a defect or problem, please do the following:

FIRST: Notify the dealership where you purchased the vehicle or had the leveling system installed. Dealership management people are in the best position to resolve the problem quickly. If the dealer has difficulty solving the problem, he should immediately contact the Customer Service Department, at HWH CORPORATION.

SECOND: If your dealer cannot or will not solve the problem, notify the Customer Service Department:
HWH CORPORATION 2096 Moscow Rd. Moscow IA. 52760
(563) 724-3396 OR (800) 321-3494. Give your name and address, coach manufacturer and model year, date the coach was purchased, or the date of system installation,

description of the problem, and where you can be reached during business hours (8:00 a.m. till 5:00 p.m. c.s.t.). HWH CORPORATION personnel will contact you to determine whether or not your claim is valid. If it is, HWH CORPORATION will authorize repair or replacement of the defective part, either by appointment at the factory or by the authorization of an independent service facility, to be determined by HWH CORPORATION. All warranty repairs must be performed by an independent service facility authorized by HWH CORPORATION, or at the HWH CORPORATION factory, unless prior written approval has been obtained from proper HWH CORPORATION personnel.

CONTROL IDENTIFICATION

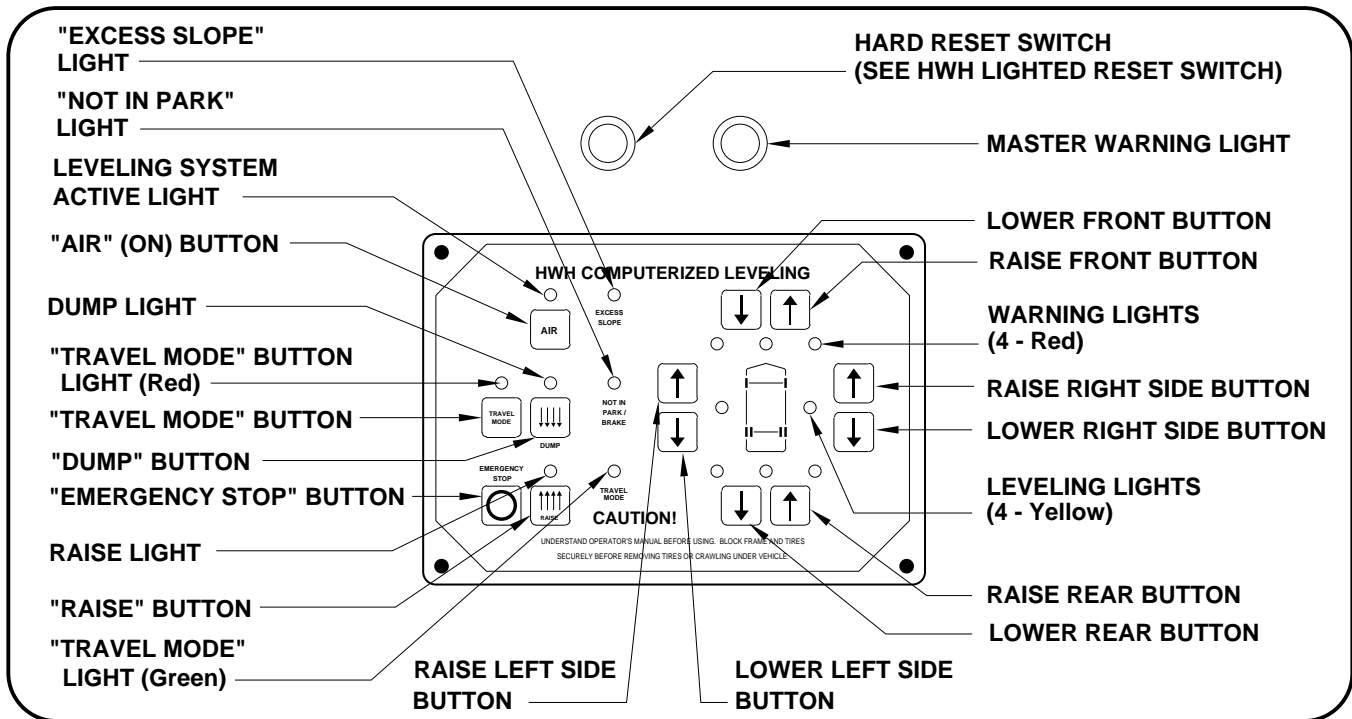

CONTROL FUNCTIONS

CONTROL BUTTONS

"AIR" BUTTON: This is the system active and automatic operation button. It works if the ignition is in the "ON" position.

"EMERGENCY STOP" BUTTON: This button turns the system OFF but does NOT control power to the "DUMP" or "RAISE" buttons. Pushing this button will NOT put the system in the TRAVEL mode.

"TRAVEL MODE" BUTTON: This button will put the Leveling System in the TRAVEL mode. The ignition must be "ON" for the vehicle to return to proper ride height for traveling.

"DUMP" BUTTON: This button will lower the whole coach by dumping air from the suspension system.

"RAISE" BUTTON: This button will raise the whole coach by adding air to the suspension system.

IMPORTANT: Read "DUMP AND RAISE FUNCTIONS" before using the "DUMP" or "RAISE" buttons.

UP ARROWS (RAISE BUTTONS): These momentary buttons are used for manually operating the air leveling systems. Sides or ends of the vehicle will raise while these buttons are pushed.

DOWN ARROWS (LOWER BUTTONS): These momentary buttons are used for manually operating the air leveling systems. Sides or ends of the vehicle will lower while these buttons are pushed.

INDICATOR LIGHTS

LEVEL SYSTEM ACTIVE LIGHT: ON when the system is active, and flashes during automatic leveling.

DUMP LIGHT: Flashes when "DUMP" button is pushed.

RAISE LIGHT: Flashes when "RAISE" button is pushed.

"EXCESS SLOPE" LIGHT: ON if the leveling system can NOT level the coach.

"TRAVEL MODE" BUTTON LIGHT (RED): Light flashes for 3 seconds after the "TRAVEL MODE" button is pushed.

"TRAVEL MODE" LIGHT (GREEN): ON if the ignition is in the "ON" position, the system is not being used, and there is sufficient air pressure in the suspension. See PREPARATION FOR TRAVEL.

WARNING LIGHTS: Function with the ignition in the "ON" position. ON when the LEVELING SYSTEM ACTIVE LIGHT is ON. See PREPARATION FOR TRAVEL.

LEVELING LIGHTS: One or two yellow lights can be on indicating the side, end or corner of the coach is low.

"NOT IN PARK/BRAKE" LIGHT: ON while the "AIR" button is being pushed if the Park Brake is NOT set. The light will go out when the "AIR" button is released.

MASTER WARNING LIGHT: ON any time the "TRAVEL" light is not ON, if the ignition is in the "ON" position.

CONTROL IDENTIFICATION

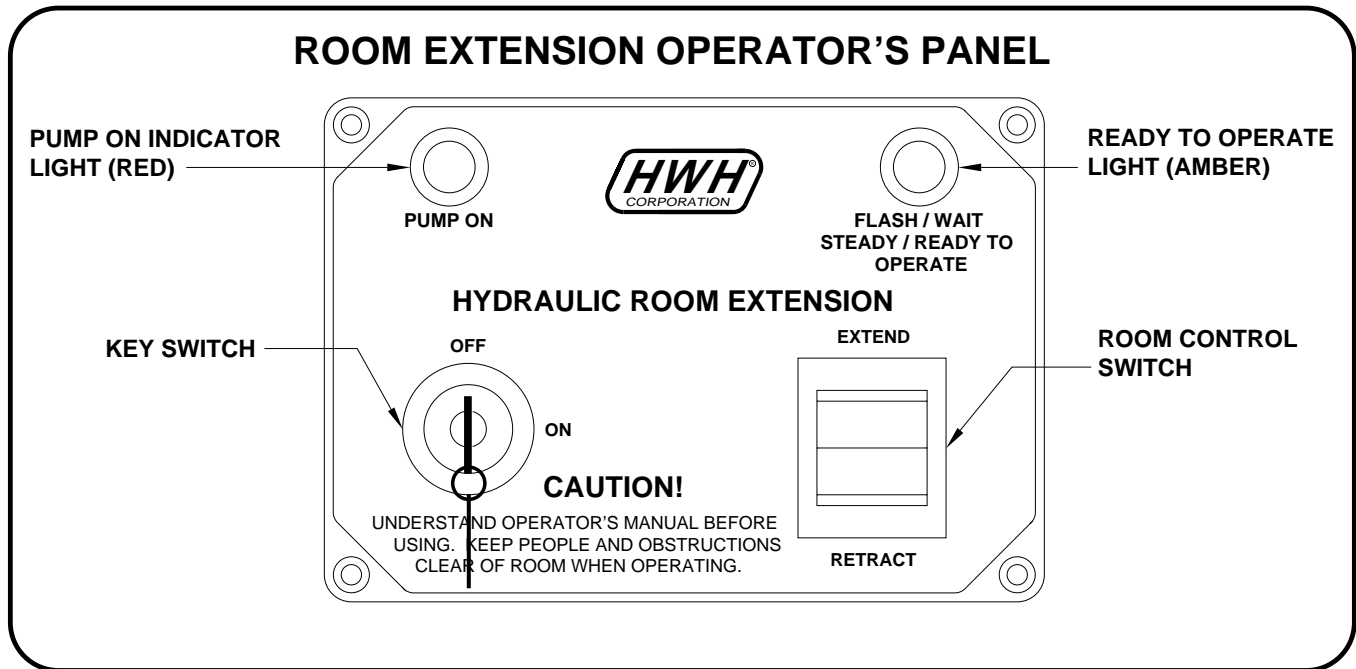

CONTROL FUNCTIONS

KEY SWITCH: The KEY SWITCH controls power to the ROOM CONTROL SWITCH. When the KEY SWITCH is in the "ON" POSITION the room can be operated, and the key cannot be removed. When the KEY SWITCH is in the "OFF" position the room cannot be operated, and the key can be removed.

NOTE: Any time the KEY SWITCH is ON, the network will be active and will not power down.

ROOM CONTROL SWITCH: The ROOM CONTROL SWITCH is a two position momentary switch. Pressing the switch in the EXTEND POSITION will extend the room. Pressing the switch in the RETRACT POSITION will retract the room. Releasing the ROOM CONTROL SWITCH will halt the operation of the room.

PUMP ON INDICATOR LIGHT: This light will be on when the pump is running.

READY TO OPERATE LIGHT: This light will flash for 20 seconds while the air seal deflates, after the KEY SWITCH is turned on. It will then glow steady. Except for EXCESS SLOPE situations, the room cannot be extended or retracted if this light is flashing.

If the "EXCESS SLOPE" light on the leveling system control panel is on, the READY TO OPERATE light will flash continuously after the key switch is turned ON. The room will not extend. The room will retract if the room control switch is pushed to "RETRACT".

If the PARK BRAKE is not set, the READY TO OPERATE light will not turn on and flash when the KEY SWITCH is turned "ON".

If a RAISE or LOWER function of the Leveling System is in use, MANUAL or AUTOMATIC operation, the READY TO OPERATE light will flash if the KEY SWITCH is in the "ON" position. The room will not operate.

MASTER WARNING LIGHT

This light is on the dash, separate from the control panels. It can be on only if the ignition key is in the "ON" position.

The light will be on if a HWH low air pressure switch is on, if the Leveling System is on, if the Leveling System is not in the TRAVEL mode, or if a room in limit switch is not made.

CONTROL IDENTIFICATION

PUMP RUN TIME

PUMP RUN TIME

Pump motors used with HWH leveling systems and room extension systems come in 3 different diameters; 3", 3.7" and 4.5". Contact the vehicle manufacturer or HWH for help with identifying the motor size. **It is important that any time the pump runs for more than three minutes with a 3" motor; or six minutes with a 3.7" or 4.5" motor that the motor is allowed to cool for thirty minutes before continuing. Continuous operation of the pump motor without allowing the motor to cool can damage the motor.** For cold weather information see "COLD WEATHER OPERATIONS" below.

The HWH systems with a computer processor monitor the pump run time and will turn the pump off if the run time exceeds a specified time. This time can vary with different systems. Due to available electronics or system design, the pump run time programs will also vary. Leveling systems and room extensions that are not controlled by a system processor have no pump run time protection. **DO NOT run the pump more than three or six minutes without allowing the pump motor to cool for thirty minutes.**

SYSTEM VARIATIONS FOR PUMP RUN TIME

Some systems with rooms run the rooms separate from the system processor. These systems do not monitor pump run time when operating the rooms. **DO NOT run the pump more than three or six minutes without allowing the pump motor to cool for thirty minutes.**

Some systems can be turned back on immediately after the processor turns the pump off. **DO NOT turn the system back on or run the pump without allowing the pump motor to cool for thirty minutes.**

When operating some leveling systems manually or operating the room extensions, the pump will turn off and back on while pushing the control button when the pump run time has been exceeded. **DO NOT continue without allowing the pump motor to cool for thirty minutes.**

With some systems, when the processor has turned the pump off because the run time has been exceeded, power to the HWH system must be turned off and back on before the system will operate. With motorized vehicles, turn the ignition off and back on. With non-motorized vehicles, turn the master power switch for the HWH system off and back on. **DO NOT continue without allowing the pump motor to cool for thirty minutes.**

Some HWH systems are equipped with a lighted reset switch. If the processor turns the pump off because the run time has been exceeded, the light in the reset switch will turn on. The system will not operate until the reset switch is pushed.

DO NOT continue without allowing the pump motor to cool for thirty minutes.

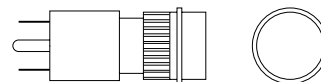

LIGHTED RESET SWITCH

No matter what HWH system is on the vehicle, the pump should not be ran for more than three minutes (3" motors) or six minutes (3.7" or 4.5" motors) without allowing the pump motor to cool for thirty minutes. Continuous operation of the pump motor without allowing the motor to cool can damage the pump motor.

Contact HWH corporation to get specific information about the system in this vehicle.

COLD WEATHER OPERATIONS

HWH leveling and room extension systems are designed to function in cold weather down to 0 degrees Fahrenheit. Below freezing (32 degrees Fahrenheit) the jacks or rooms will operate slower than usual.

For operation in temperatures dropping below -20 degrees Fahrenheit, it is necessary that the system is equipped with oil designed for extreme cold weather application such as a synthetic oil. (Contact HWH for recommendations.)

DO NOT run the pump motor continuously. It is important that any time the pump runs for more than three minutes with a 3" motor; or six minutes with a 3.7" or 4.5" motor that the motor is allowed to cool for thirty minutes before continuing. Continuous operation of the pump motor without allowing the motor to cool can damage the motor. Continuous operation of the pump with slow moving jacks or rooms in cold weather, without allowing the pump motor to cool will cause the pump motor to burn up and damage the pump assembly.

OPERATING PROCEDURES

NETWORK INFORMATION

The HWH 2000 series CAN system is a computerized modular network. It controls all functions of the leveling system and the room extensions. The network is active any time the ignition is in the "ON" position or when any room extension control panel key is "ON". Certain functions and indicator lights for the leveling system will work when the network is active. Certain functions and lights will work ONLY if the the ignition is in the "ON" position to start the function.

NOTE: The network will stay active for 10 minutes after the ignition key and all room extension control panel keys have been turned "OFF". If the leveling system was turned "ON", the network will stay active for 10 minutes after automatic leveling is complete or the system goes "EXCESS SLOPE". If manual leveling buttons were used, the network stays active for 10 minutes after the last manual button is released.

GENERAL INSTRUCTIONS

Maintain adequate clearance in all directions for vehicles, room extensions, doors, steps, etc.. Vehicle may move in any direction due to raising or lowering of vehicle during leveling, settling of vehicle, equipment malfunction, etc..

The MASTER WARNING LIGHT will be on if an air bag has low pressure or if a room in limit switch is not made, if the ignition is in the "ON" position.

CAUTION: DO NOT MOVE THE VEHICLE IF A ROOM IS EXTENDED. DO NOT MOVE THE VEHICLE AT SPEEDS IN EXCESS OF 5 MPH IF THE MASTER WARNING LIGHT IS ON.

The "DUMP" and "RAISE" buttons will function with the leveling system and park brake off, if the ignition is in the "ON" position or if the network is active. See AIR DUMP AND RAISE FUNCTIONS section of this manual.

If the Park Brake is not set, the Leveling System cannot be turned ON and the room extension will not operate.

If a ROOM CONTROL SWITCH is being pushed, no other room or the Leveling System can be operated. If any Leveling System raise or lower function is being operated, no room control switch will work.

NEUTRAL HOLD OVERRIDE SWITCH

If a room is not fully retracted, the transmission will not shift out of "NEUTRAL".

If the rooms are fully retracted and the transmission will not shift out of NEUTRAL, using a key or a screwdriver turn the HOLD OVERRIDE selector switch to the position labeled

"220" the switch is located on the outside of the Central Control Module. This will allow the transmission to be shifted. The system should be serviced as soon as possible. The HOLD OVERRIDE selector switch should be left in the "110" position for normal operation.

HWH LIGHTED RESET SWITCH

The HWH lighted reset switch is located on the shifter panel. If there is a failure at any time in the HWH CAN network, the network will shut down. The leveling system and all room extensions will not operate. If the ignition is off, no indicator lights will come on. If the ignition is in the "ON" position, the lighted reset switch and the MASTER WARNING Light will come on.

If the lighted reset switch is on, the switch must be pushed before any room or the leveling system can be operated.

Excessive operation of the hydraulic pump can shut the HWH CAN network down. The lighted reset switch will be on if the ignition is on. The reset button must be pushed before any operation can continue. Allow the pump to cool before continuing hydraulic operations.

A network problem with one room will not inhibit the use of the other rooms or leveling system after the reset switch is pushed.

A network problem with the leveling system will not inhibit the use of the room extensions after the reset switch is pushed.

If the lighted reset switch will not go out when pushed, there is a problem with the central control module of the network system. No rooms or the Leveling System will operate. The vehicle suspension will return to the travel mode if the ignition key is in the "ON" position.

CAUTION: IF THE IGNITION IS IN THE "ON" POSITION AND THE LIGHTED RESET SWITCH IS ON, THE VEHICLE CAN RETURN TO RIDE HEIGHT WITHOUT RELEASING THE PARK BRAKE.

OPERATING PROCEDURES

PREPARATION FOR TRAVEL

Check that all room extensions are fully retracted. The green "TRAVEL MODE" light on the touch panel will not be on if a room is extended. The MASTER WARNING light will be ON. (SEE ROOM RETRACT PROCEDURES)

Visually check that the vehicle is at the proper ride height for traveling.

The ignition must be in the "ON" position for the vehicle suspension to be in the travel mode. Also the "TRAVEL MODE" button must be pushed or the park brake released for the suspension to be in the travel mode If the Leveling System was used.

A lit "TRAVEL MODE" light indicates that the HWH Leveling System is in the TRAVEL MODE. It does not indicate that the suspension is at ride height or that the coach is ready to travel.

CAUTION: IT IS THE OPERATOR'S RESPONSIBILITY TO CHECK THAT THE VEHICLE IS AT PROPER RIDE HEIGHT AND ALL SLIDE-OUTS ARE FULLY RETRACTED BEFORE TRAVELING.

Before traveling, the MASTER WARNING light must be off and the "TRAVEL MODE" light must be ON.

NOTE: Low air pressure or an extended room can turn the green "TRAVEL MODE" light off and turn the MASTER WARNING light on.

Refer to "DUMP" and "RAISE" FUNCTIONS operating procedures when moving the vehicle with the suspension NOT at the proper ride height.

AUTOMATIC AIR OPERATION

NOTE: The ignition must be in the "ON" position to use the "AIR" button. Once the operation is started, the ignition can be moved to the "OFF" position and the operation will continue. If a ROOM CONTROL switch is being pushed, the Leveling System can not be operated.

1. Place the transmission in the proper position for parking and set the park brake. The air leveling system can only be turned on if the ignition is in the "ON" position. Leaving the engine running during leveling is recommended. This will provide a better air supply for leveling. The vehicle will level with the engine shut off, however more time will be required for leveling.

NOTE: If the ignition key is in the "ON" position, the panel will not turn on if the park brake is not set. The "NOT IN PARK/BRAKE" light will be on while the "AIR" button is being pushed.

2. Make sure the Tag Lift switch is in the OFF position.

3. Press the "AIR" button once to enter the air mode. The LEVELING SYSTEM ACTIVE LIGHT will glow steady. When the ignition is in the "ON" position, the four red WARNING lights on the panel will come on. This indicates that the height control valves have been locked out. The vehicle should not be moved when these lights are on.

4. Press the "AIR" button a second time. The LEVELING SYSTEM ACTIVE LIGHT will start flashing and air leveling will begin. The system will attempt to level the vehicle by exhausting air from the air bags. If a level position is not achieved by lowering the vehicle, the low side and/or end of the vehicle will be raised by adding air to the air bags. When all four yellow LEVEL SENSING lights are out the leveling is complete.

NOTE: Only one or two yellow LEVEL SENSING lights may be ON at one time.

5. When all four yellow level lights are out, the LEVELING SYSTEM ACTIVE LIGHT will stop flashing and start pulsating dimly. The Leveling System is now in the SLEEP MODE. The vehicle's engine/ignition may now be turned OFF.

NOTE: After the ignition and all room extension KEY SWITCHES are turned OFF, the CAN Network stays active for 10 minutes before shutting down. Leveling System touch panel lights will stay ON during this time and go out when the CAN Network shuts down. If the Leveling System is in the SLEEP MODE when the Network shuts down, the computer will stay ON. The Leveling System touch panel lights will all be OFF, but the Leveling System will still be in the SLEEP MODE.

6. During the Sleep Mode, after 30 minutes the processor checks the Level Sensing Unit inputs. If no input for a yellow level light is seen, the processor remains dormant and will recheck the level unit inputs every thirty minutes. If a yellow level light input is on for one minute continuously, the processor will relevel the vehicle, then return to the sleep mode.

NOTE: Touch Panel Lights will not be ON unless the system is actively leveling the vehicle.

7. If the vehicle needs to be relevelled, the CAN Network will become active. The LEVELING SYSTEM ACTIVE LIGHT will flash. One or two yellow LEVELING LIGHTS will be ON. When the yellow LEVELING LIGHTS are all out, the LEVELING SYSTEM ACTIVE LIGHT will stop flashing and start pulsating dimly. The Leveling System will remain in the SLEEP MODE with the computer monitoring the LEVELING SENSING UNIT every 30 minutes, releveling the vehicle as needed.

OPERATING PROCEDURES

AUTOMATIC AIR OPERATION (Continued)

NOTE: The CAN Network will stay active for 10 minutes after releveling the vehicle and then shut down, turning the touch panel lights OFF. This happens every time the system relevels the vehicle.

7. The SLEEP MODE will continue until the "EMERGENCY STOP" button is pushed or the park brake is released, if the ignition is in the "ON" position.

EXCESS SLOPE: The system will attempt to level the vehicle for approximately 15 to 20 minutes. After the 15 to 20 minutes, if a LEVEL SENSING light is still on, the "EXCESS SLOPE" light will come on. The LEVEL LIGHT indicator light will go out. The "EXCESS SLOPE" light will be on whenever the network is active.

NOTE: Room extensions can not be extended if the "EXCESS SLOPE" light is on but they can be retracted.

The "EXCESS SLOPE" light will be on whenever the network is active until the vehicle is manually leveled with all yellow LEVEL indicator lights off. Releasing the park brake with the ignition on will turn the "EXCESS SLOPE" light off.

TAG AXLE DUMP

The tag axle dump switch is supplied by Foretravel.

IMPORTANT: Refer to Foretravel for proper use of the TAG DUMP feature.

The tag dump switch will work only with the ignition switch in the "ON" position and the Leveling System panel off.

If the TAG DUMP switch is in the DUMP position and the ignition key is turned ON (with the Leveling System panel OFF) the tag axle air bags will go into the dump mode.

The tag axle dump switch will not work if the vehicle is moving at a speed in excess of approximately 10 mph.

The TAG DUMP switch, in either the DUMP or OFF position, will not interfere with any air leveling operations.

NOTE: It is better to have the TAG DUMP switch in the OFF position before using the leveling system.

When the TAG DUMP switch is in the DUMP position, with the ignition switch on, the tag axle manifold tag enable valves are off. When the TAG DUMP switch is in the TRAVEL position, with the ignition switch on, the tag axle manifold tag enable valves will be on. Whenever the LEVELING SYSTEM ACTIVE light is on, the tag axle manifold travel valves will be on.

OPERATING PROCEDURES

MANUAL AIR OPERATION

NOTE: The ignition must be in the "ON" or "ACC" position to use the "AIR" button. Once the operation is started, the ignition can be moved to the "OFF" position and the operation will continue.

1. Place the transmission in the proper position for parking and set the park brake. The air leveling system can only be turned on if the ignition is in the "ON" position. Running the vehicle engine during leveling is recommended. This will provide a better air supply for leveling. The vehicle will level with the engine shut off, however more time will be required for leveling.

NOTE: If the "NOT IN PARK/BRAKE" light is on, the leveling system cannot be turned on.

2. Press the "AIR" button once to enter the air mode. The LEVELING SYSTEM ACTIVE LIGHT indicator light will glow steady. When the ignition is in the "ON" position, the four red WARNING lights on the panel will come on. This indicates that the height control valves have been locked out. The vehicle should not be moved when these lights are on.

3. The vehicle can now be leveled using the RAISE (up arrow) and LOWER (down arrow) buttons on the right half of the

panel in conjunction with the yellow LEVEL indicator lights. **Any side to side leveling should be done, if needed, before leveling the vehicle front to rear.** The yellow LEVEL indicator light indicates that side or end is low. When all yellow lights are out the vehicle is level. Try leveling the vehicle by lowering the high side or end (opposite of the lit yellow level lights). If a level position is not achieved use the RAISE (up arrow) button to raise the low side or end.

NOTE: In either manual or automatic leveling when either front air manifold air bag pressure switch is on a front lower procedure is halted. When either rear air manifold air bag pressure switch is on, a rear lower procedure is halted. Air bag pressure switches will not interfere with either a right or left lower procedure.

4. Turn the ignition to the "OFF" position.

5. Turn the system off.

NOTE: If the "DUMP" or "RAISE" buttons are pushed while manually leveling the vehicle with air and the ignition is in the "ON" position, the system will latch into the dump or raise mode until the "EMERGENCY STOP" button is pushed or the ignition is turned off.

"DUMP" AND "RAISE" FUNCTIONS

The "DUMP" and "RAISE" functions are provided for operator convenience for purposes such as dumping the air suspension when parked.

Leave the engine running if the "RAISE" function is to be used. The park brake does not have to be set to use the "DUMP" or "RAISE" buttons.

IMPORTANT: If the ignition is ON and the park brake is OFF, the "DUMP" and "RAISE" features will latch in and remain on. If the vehicle exceeds 10 MPH, the "DUMP" or "RAISE" functions will automatically turn off and the system will return to the TRAVEL MODE. If the park brake is set, the "TRAVEL MODE" button must be pushed before the vehicle can return to ride height.

CAUTION: REREAD CAUTIONS ON THE FIRST PAGE OF THIS MANUAL. THE VEHICLE MAY DROP OR RAISE AND/OR MOVE FORWARD OR BACKWARD WITHOUT WARNING CAUSING INJURY OR DEATH.

DO NOT OPERATE THE VEHICLE UNLESS THE AIR SUSPENSION IS AT THE PROPER HEIGHT FOR TRAVEL.

The "RAISE" and "DUMP" buttons can be used at any time the network is active. The park brake does not have to be on.

If the ignition is in the "ON" position and the park brake is off, the "RAISE" or "DUMP" buttons will latch in. The vehicle will raise or lower completely and stay in that position. The vehicle can not return to ride height until the "TRAVEL MODE" button or the "EMERGENCY STOP" button is pushed or the vehicle exceeds 10 M.P.H, putting the system in the TRAVEL MODE.

If the ignition is in the "OFF" position the "RAISE" and "DUMP" buttons will not latch in. The vehicle will remain in the position it was when the button was released. The vehicle can return to ride height when the ignition is turned to "ON" if the park brake is released or the "TRAVEL MODE" button is pushed.

DO NOT operate the vehicle for extended distances unless the air suspension is at the proper height for travel. The vehicle can not return to ride height until the "EMERGENCY STOP" button is pushed or the vehicle exceeds 10 MPH, putting the system in the TRAVEL MODE.

CAUTION: IT IS THE OPERATOR'S RESPONSIBILITY TO CHECK THAT THE VEHICLE IS AT PROPER RIDE HEIGHT BEFORE TRAVELING.

OPERATING PROCEDURES

ROOM EXTEND PROCEDURE

IMPORTANT: It is recommended to level the vehicle before extending the room.

1. The park brake must be set for the room to be operated. If the "EXCESS SLOPE" light on the touch panel is on, the room cannot be extended.

Make sure the door or a window is open while extending a room.

IMPORTANT: If the "EXCESS SLOPE" light is ON, the vehicle must be re-leveled so all yellow LEVEL indicator lights on the touch panel are OFF before the room can be extended. If any of the four yellow LEVEL indicator lights cannot be put out, the vehicle should be moved to a more level location before using the room extension.

CAUTION: KEEP PEOPLE AND OBSTRUCTIONS CLEAR OF ROOM WHEN OPERATING.

NOTE: Make sure there is adequate clearance to fully extend the room.

2. Insert the KEY into the KEY SWITCH on the room extension operator's panel and turn it to the "ON" position. The READY TO OPERATE light will flash. When the amber light is on steady the room can be operated.

NOTE: Anytime the KEY SWITCH is on, the room air seal will deflate.

NOTE: If the Leveling System is being operated, the room will not extend. If the room panel KEY SWITCH is on, the "READY TO OPERATE" light will flash while the Leveling System is being operated.

3. To extend the room, push and hold the ROOM CONTROL SWITCH in the extend position. The red PUMP ON light will come on. There may be a delay of several seconds (no more than 10 seconds) before the PUMP ON light comes on after the switch is pushed. When the room is fully extended, the pump will automatically shut off. The red PUMP ON light will go out. Do not release the ROOM CONTROL SWITCH, until the red PUMP ON light goes out. **If the red PUMP ON light remains on 30 seconds after the room is fully extended release the room control switch.**

NOTE: The room is equipped with an air seal, the air seal is monitored by a vacuum switch to make sure the air seal is deflated. This may cause a delay in room operation when the Room Control switch is pushed. While the Room Control Switch is being pushed a loss of vacuum in the air seal will not halt the movement of the room unless the Room Control switch is released. The Room Control switch will not work until the vacuum switch is made.

NOTE: Under normal operation of the room, the direction of movement should not be reversed. If the movement of the room must be reversed, do not try to re-extend the room until the room has been fully retracted.

IMPORTANT: IF EITHER SIDE OF THE ROOM STOPS MOVING, RELEASE THE ROOM CONTROL SWITCH IMMEDIATELY. THE ROOM OPERATION WILL HALT. DO NOT FORCE THE ROOM. DO NOT REVERSE DIRECTION OF THE ROOM. BINDING OF ROOM CAN CAUSE ROOM DAMAGE. CONTACT HWH CORPORATION CUSTOMER SERVICE FOR ASSISTANCE.

NOTE: The READY TO OPERATE light will flash when the room control switch is pushed if the "EXCESS SLOPE" light on the Leveling System panel is ON. The room will not extend.

4. Turn the KEY SWITCH to the "OFF" position and remove the key. The READY TO OPERATE light will go out. The air seal will inflate.

NOTE: If the KEY SWITCH is left "ON" the air seal will not inflate and the Network will stay active and not power down.

OPERATING PROCEDURES

ROOM RETRACT PROCEDURE

CAUTION: KEEP PEOPLE AND OBSTRUCTIONS CLEAR OF ROOM WHEN OPERATING.

Make sure the door or a window is open while extending a room.

1. The park brake must be set for the room to be operated.

IMPORTANT: It is recommended that the coach is level before retracting the room.

2. Insert the KEY into the KEY SWITCH on the room extension operator's panel and turn it to the "ON" position. The air seal will deflate. The READY TO OPERATE light will flash. When the amber light is on steady the room can be operated.

NOTE: If the Leveling System is being operated, the room will not retract. If the room panel KEY SWITCH is on, the "READY TO OPERATE" light will flash while the Leveling System is being operated.

3. To retract the room, push and hold the ROOM CONTROL SWITCH in the retract position. The red PUMP ON light will come on. There may be a delay of several seconds (no more than 10 seconds) before the PUMP ON light comes on after the switch is pushed. When the room is fully retracted, the pump will automatically shut off. The red PUMP ON light will go out. Do not release the ROOM CONTROL SWITCH, until the red PUMP ON light goes out. **If the red PUMP ON light remains on 30 seconds after the room is fully retracted release the room control switch.**

NOTE: The room is equipped with an air seal, the air seal is monitored by a vacuum switch to make sure the air seal is deflated. This may cause a delay in room operation when the Room Control switch is pushed. While the Room Control Switch is being pushed a loss of vacuum in the air seal will not halt the movement of the room unless the Room Control switch is released. The Room Control switch will not work until the vacuum switch is made.

NOTE: Under normal operation of the room, the direction of movement should not be reversed. If the movement of the room must be reversed, do not try to retract the room until the room has been fully extended.

IMPORTANT: IF EITHER SIDE OF THE ROOM STOPS MOVING, RELEASE THE ROOM CONTROL SWITCH IMMEDIATELY. THE ROOM OPERATION WILL HALT. DO NOT FORCE THE ROOM. DO NOT REVERSE DIRECTION OF THE ROOM. BINDING OF ROOM CAN CAUSE ROOM DAMAGE. CONTACT HWH CORPORATION CUSTOMER SERVICE FOR ASSISTANCE.

4. Turn the KEY SWITCH to the "OFF" position and remove the key. The READY TO OPERATE light will go out. The air seal will inflate.

NOTE: If the KEY SWITCH is left "ON" the air seal will not inflate and the Network will stay active and not power down.

IN THE EVENT OF THE FAILURE OF THE ROOM TO RETRACT, CONTACT HWH CORPORATION CUSTOMER SERVICE AT 1-800-321-3494 FOR ASSISTANCE.

OPERATING PROCEDURES

GENERATOR SLIDE EXTEND PROCEDURE

CAUTION: KEEP PEOPLE AND OBSTRUCTIONS CLEAR OF SLIDE WHEN OPERATING.

NOTE: Make sure there is adequate clearance to fully extend the slide.

1. THE PARK BRAKE MUST BE SET FOR THE SLIDE TO OPERATE.

2. To extend the slide, press and hold the GENERATOR SLIDE CONTROL SWITCH in the "EXTEND" position. When the slide is fully extended, release the GENERATOR SLIDE CONTROL SWITCH.

IMPORTANT: Do not hold the GENERATOR SLIDE CONTROL SWITCH in the "EXTEND" position for more than ten seconds after the slide is fully extended or stops moving. **DO NOT FORCE THE SLIDE.**

NOTE: Releasing the GENERATOR SLIDE CONTROL SWITCH will halt the operation of the slide.

GENERATOR SLIDE RETRACT PROCEDURE

1. THE PARK BRAKE MUST BE SET FOR THE SLIDE TO OPERATE.

2. To retract the slide, press and hold the GENERATOR SLIDE CONTROL SWITCH in the "RETRACT" position. When the slide is fully retracted, release the GENERATOR SLIDE CONTROL SWITCH.

IMPORTANT: Do not hold the GENERATOR SLIDE CONTROL SWITCH in the "RETRACT" position for more than ten seconds after the slide is fully retracted or stops moving. **DO NOT FORCE THE SLIDE.**

NOTE: Releasing the GENERATOR SLIDE CONTROL SWITCH will halt the operation of the slide.

3. If the slide will not retract see the MANUAL SLIDE RETRACT PROCEDURE.

SENSING UNIT MAINTENANCE/SERVICE

SENSING UNIT ACCURACY TOLERANCE

The sensing unit has an accuracy tolerance of ± 5.4 inches front to rear and ± 1 inch side to side on a 36 foot vehicle. Typical leveling results will be better.

SENSING UNIT ADJUSTMENT

To adjust the sensing unit, first the vehicle must be level. Either position the vehicle on a level surface or use the leveling system to manually level the vehicle. It is recommended to use the vehicle trim line to determine level. An alternative would be to use a small bubble level. If using a bubble level, the level should be placed on a flat surface close to the mounting location of the control box/sensing unit.

With the vehicle level, if there are no yellow light lit on the Touch Panel, the sensing unit is properly adjusted. If there are yellow LEVEL lights lit on the Touch Panel, manual adjustments to the Sensing Unit are needed. A Phillips screw driver or sockets w/driver or box end wrenches of 7/8, 3/4, 1/2, 5/16 or 1/4 sizes will be needed.

The Sensing Unit is mounted inside the Control Box. The Control Box is mounted to the power unit/valve assembly.

There are four LED's on the Sensing Unit, A,B,C and D. Refer to the drawing below. The Sensing Unit is adjusted by turning the adjustment nut to turn out LED's B and D. The adjustment screw will turn out LED's A and C. If the adjustment nut has to be turned more than 1/2 flat or the adjustment screw has to be turned more than 3/4 turn to turn the LED out, there may be a problem with the Sensing Unit or the mounting of the Control Box. If two LED's are on, it is best to make the B-D adjustments first, then hold the adjustment nut from moving while making the A-C adjustment.

NOTE: If opposing LED's are lit, there is a problem with the Sensing Unit.

If LED (A) is lit: Turn the adjustment screw COUNTER CLOCKWISE until the LED is off.

If LED (C) is lit: Turn the adjustment screw CLOCKWISE until the LED is off.

If LED (B) is lit: Turn the adjustment nut COUNTER CLOCKWISE until the LED is off.

If LED (D) is lit: Turn the adjustment nut CLOCKWISE until the LED is off.

IMPORTANT: When all 4 LED's are off, move the vehicle to an unlevel position so one or two yellow lights are on. Level the vehicle according to the yellow LEVEL lights. Recheck the level. If more adjustment is needed, DO NOT try to adjust the sensing unit until the yellow level lights go out, instead just "tweak" the sensing unit, ignoring the LED's on the sensing unit.

Example: After the initial adjustment and releveling the vehicle, the front is still low. This means the front yellow level light is turning off too soon. Determine which sensing unit light is the front light, A-B-C or D. Move the adjustment for that light very, very, slightly in the OPPOSITE direction that is given in the above instructions for LED's A, B, C, and D. This will allow the front yellow light to stay on slightly longer to bring the front up more. Again, unlevel the vehicle then relevel the vehicle using the yellow level lights on the touch panel. Recheck with a level. Repeat the "tweaking" process until the system levels the vehicle properly.

TOP VIEW - SENSING UNIT

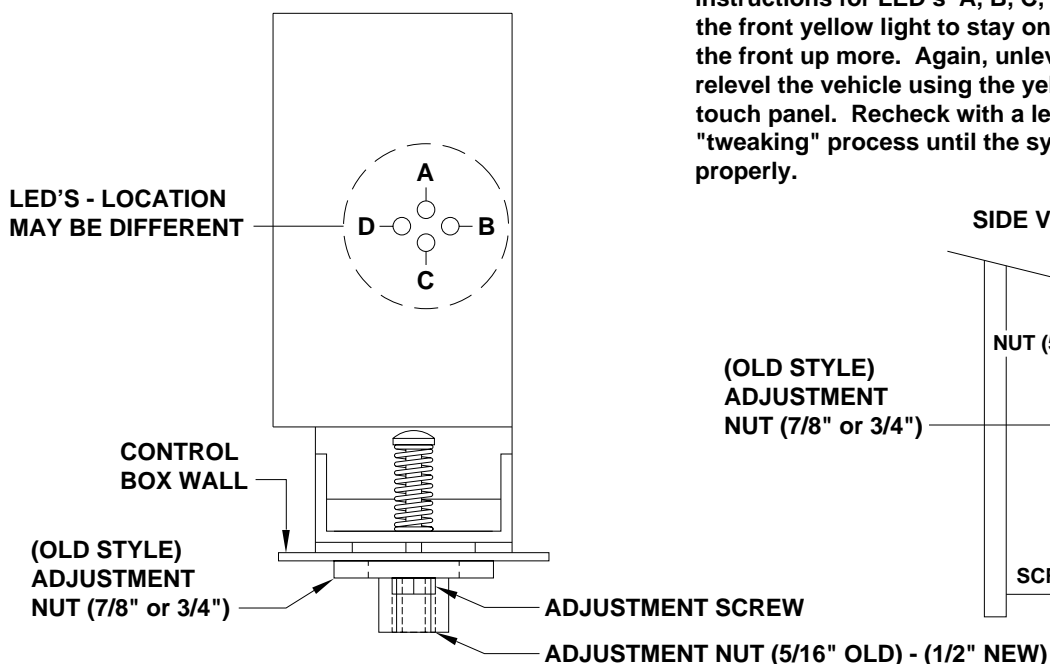

SIDE VIEW - CONTROL BOX

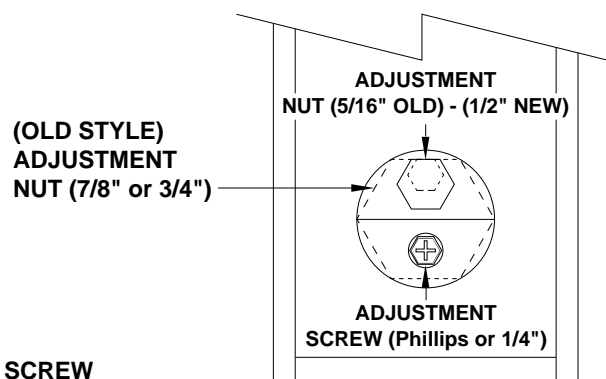

MAINTENANCE

OIL LEVEL

It is important that all front rooms and the generator slide are fully retracted before checking the hydraulic oil level. If the coach has a bed slide, the bed slide must be fully retracted before checking the hydraulic oil level. If the coach has a wardrobe slide, the wardrobe slide must be fully extended before checking the hydraulic oil level. To check the oil supply, remove the breather cap from the top of the hydraulic oil reservoir. The oil level should be approximately one inch below the top of the reservoir when adequately filled.

FLUID: HWH Specialty Hydraulic Oil is recommended. In an emergency Dexron automatic transmission fluid can be used.

NOTE: Dexron automatic transmission fluid contains red dye and can cause staining should a leak occur. **DO NOT USE** brake fluid or hydraulic jack fluid. Use of these can damage seals.

HYDRAULIC LINE CONNECTION DIAGRAM MULTIPLE EXTENSIONS

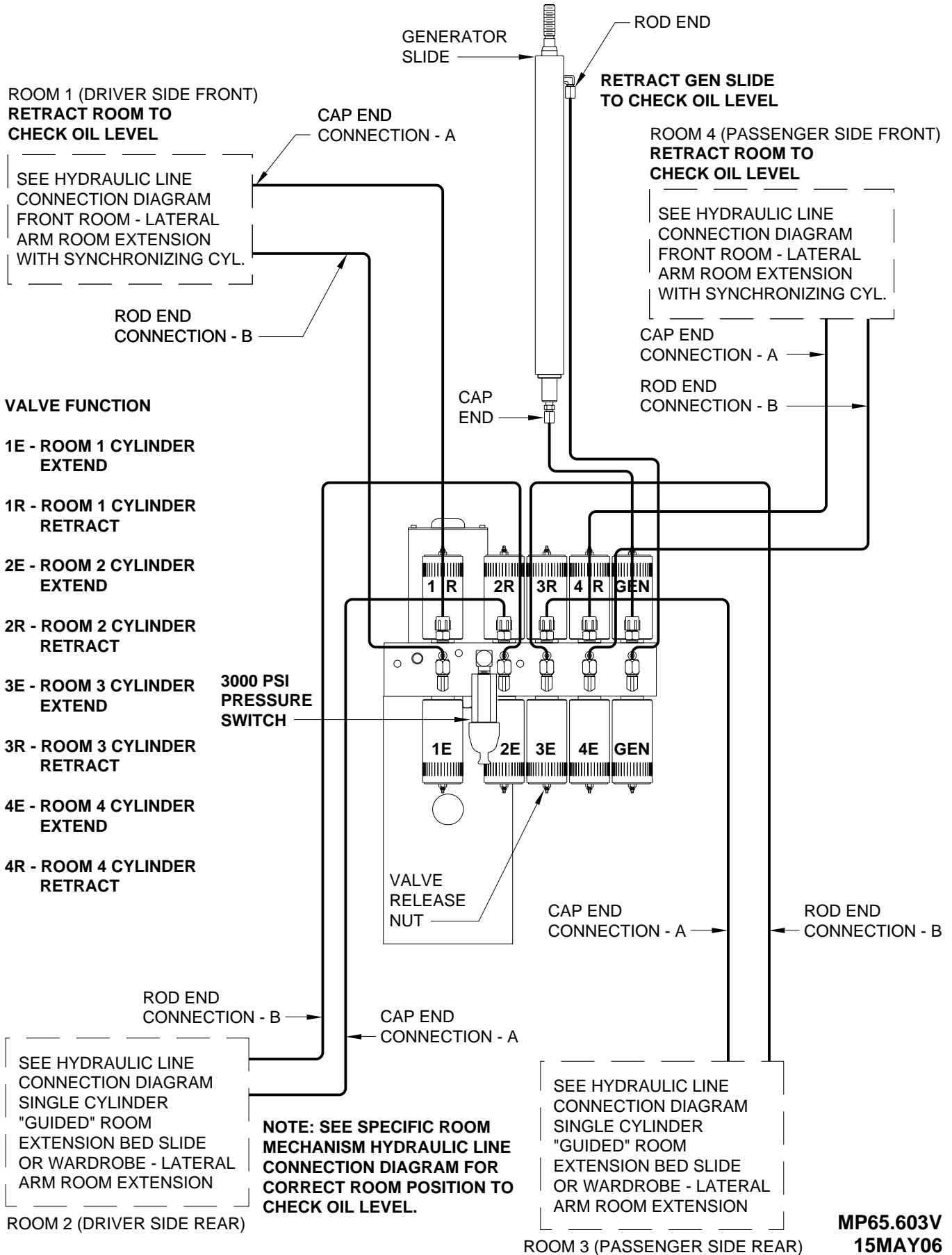

HYDRAULIC LINE CONNECTION DIAGRAM

WARDROBE - LATERAL ARM ROOM EXTENSION

(WITH SYNCHRONIZING CYLINDER)

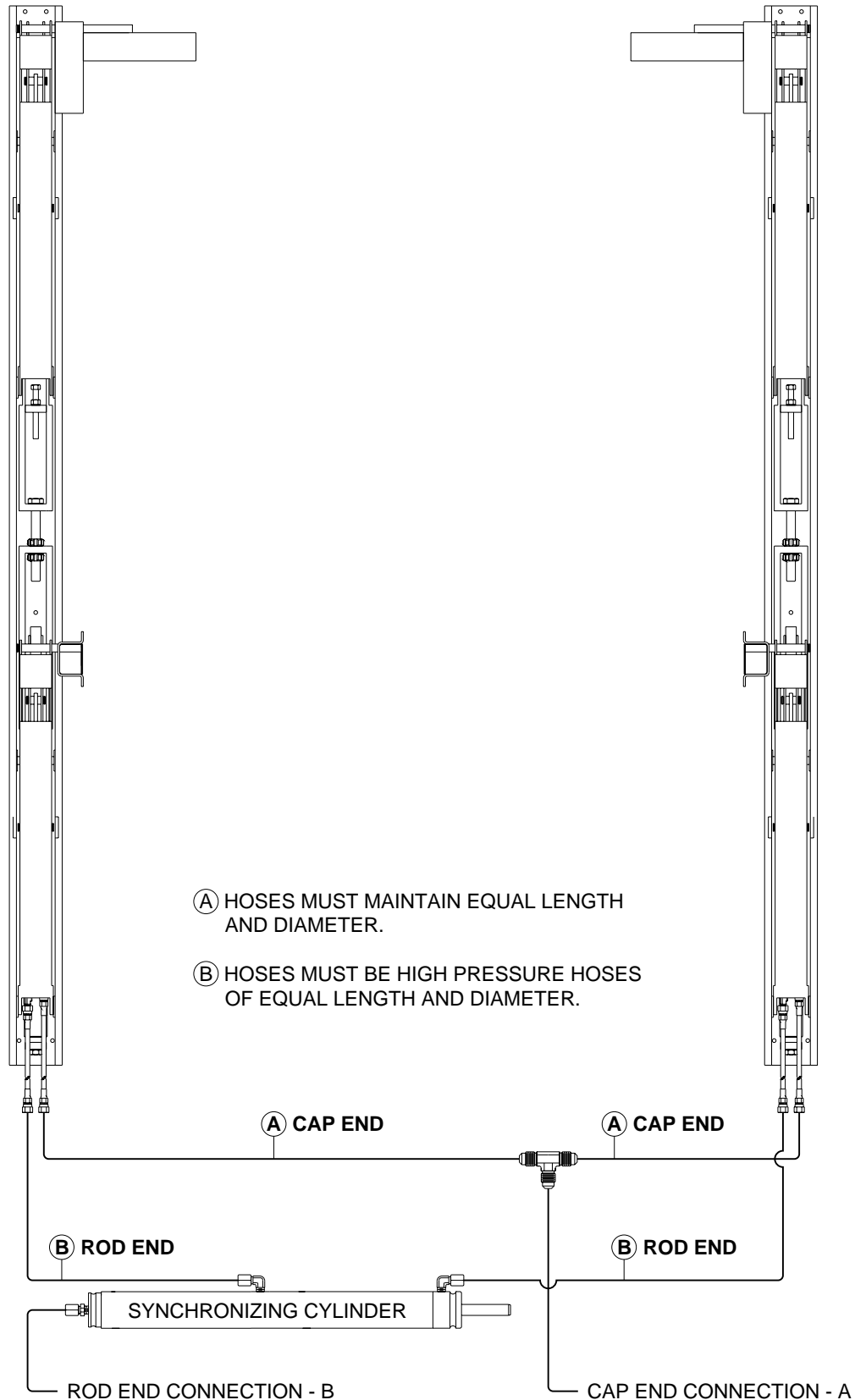

CYLINDER EXTEND - ROOM RETRACT
CYLINDER RETRACT - ROOM EXTEND
CHECK OIL LEVEL WITH ROOM EXTENDED

MP65.800V
29NOV05

HYDRAULIC LINE CONNECTION DIAGRAM FRONT ROOM - LATERAL ARM ROOM EXTENSION (WITH SYNCHRONIZING CYLINDER)

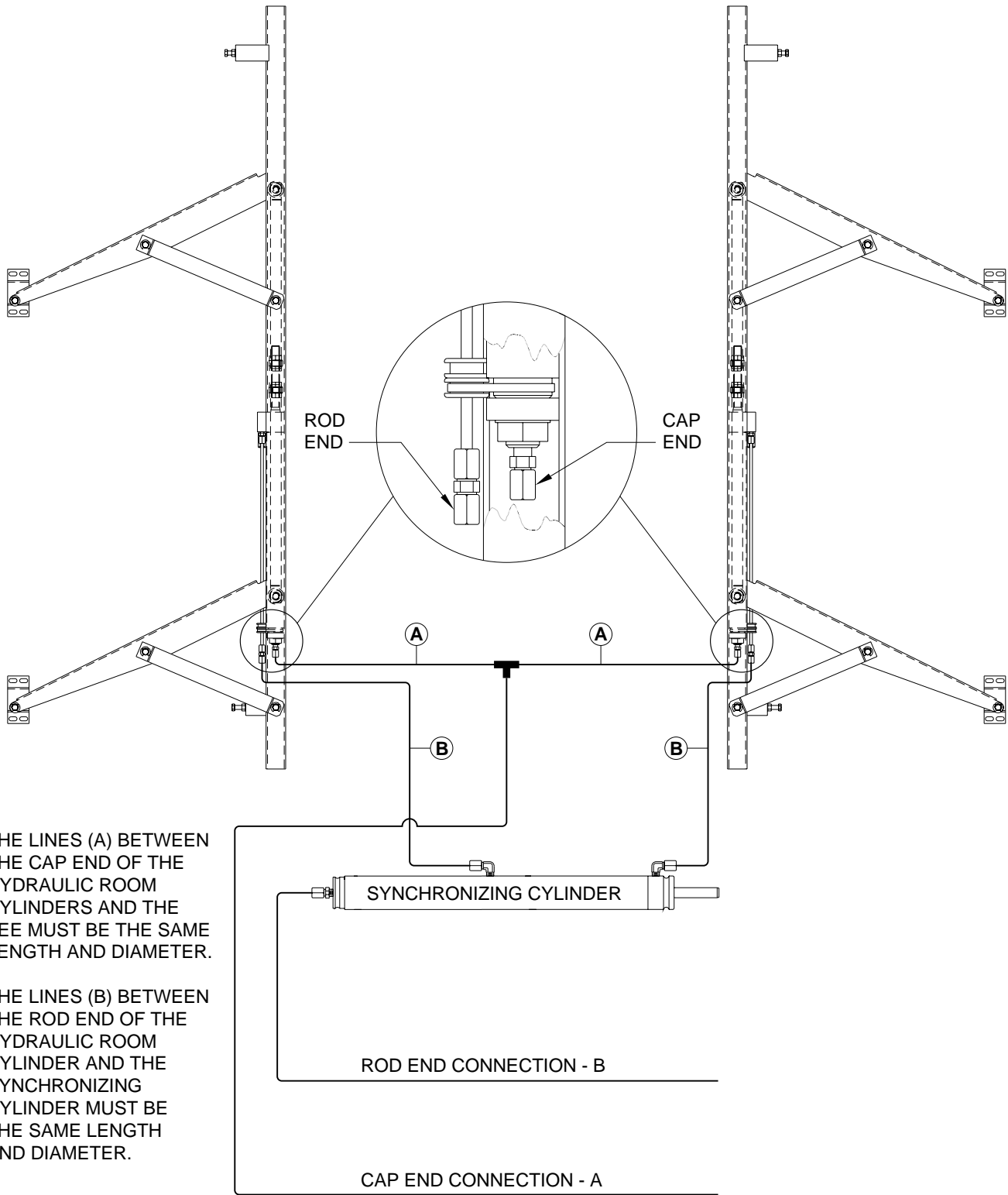

THE LINES (A) BETWEEN THE CAP END OF THE HYDRAULIC ROOM CYLINDERS AND THE TEE MUST BE THE SAME LENGTH AND DIAMETER.

THE LINES (B) BETWEEN THE ROD END OF THE HYDRAULIC ROOM CYLINDER AND THE SYNCHRONIZING CYLINDER MUST BE THE SAME LENGTH AND DIAMETER.

CYLINDER EXTEND - ROOM EXTEND
CYLINDER RETRACT - ROOM RETRACT
CHECK OIL LEVEL WITH THE ROOM RETRACTED

HYDRAULIC LINE CONNECTION DIAGRAM

REAR SINGLE CYLINDER "GUIDED" ROOM EXTENSION

BED SLIDE

NOTE: THE ROD END CONNECTION FROM THE MANIFOLD TO THE ROOM CYLINDER IS ALWAYS PRESSURIZED.

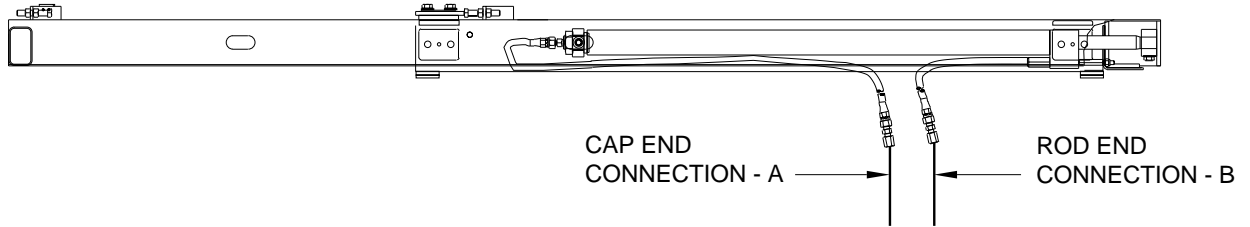

CYLINDER EXTEND - ROOM EXTEND
CYLINDER RETRACT - ROOM RETRACT
CHECK OIL LEVEL WITH ROOM RETRACTED.

**HYDRAULIC FLOW DIAGRAM
VERTICAL ARM OR DUAL CYLINDER ROOM EXTENSION
WITH SYNCHRONIZING CYLINDER
STATIONARY POSITION**

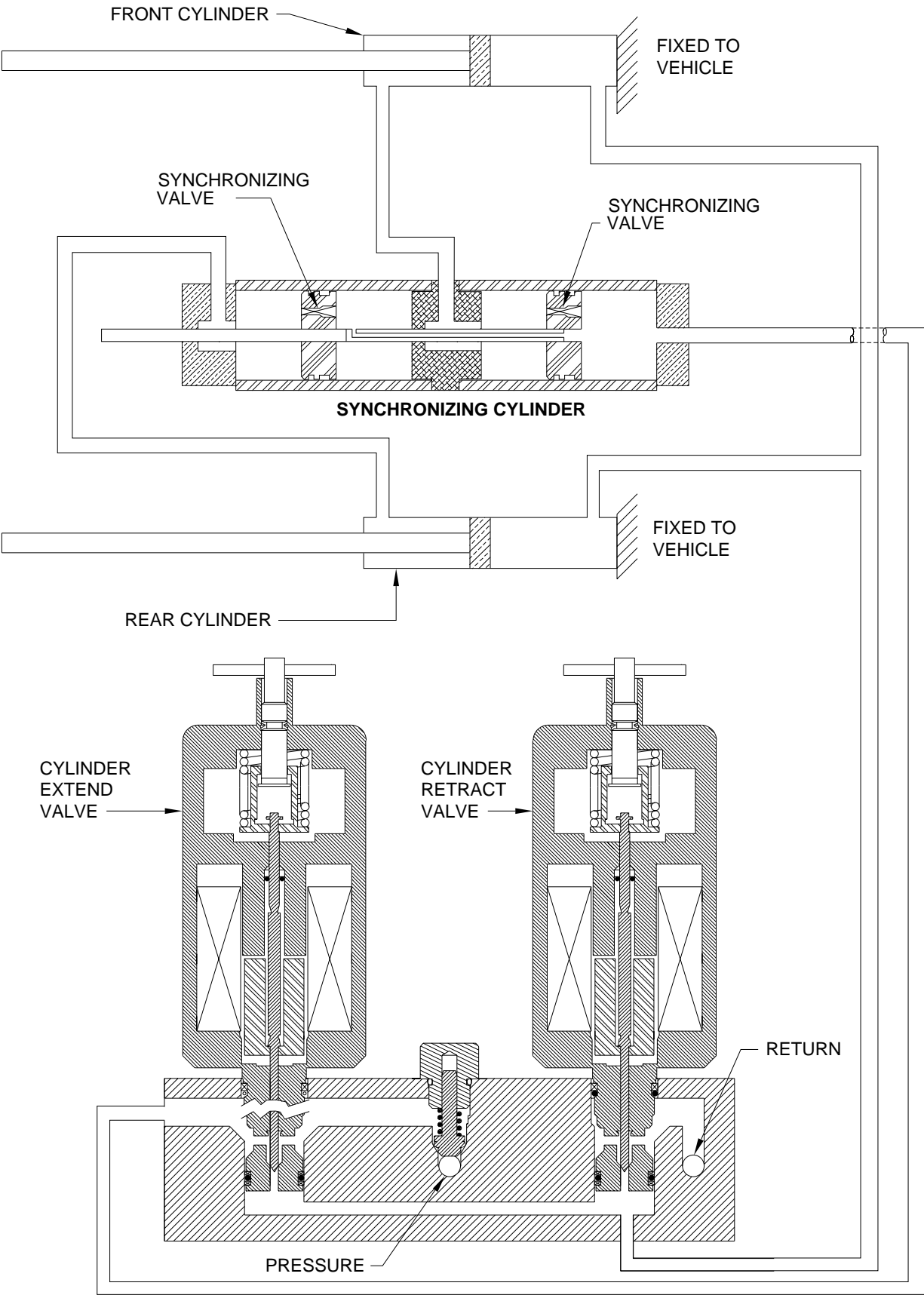

**HYDRAULIC FLOW DIAGRAM
SINGLE CYLINDER ROOM EXTENSION
STATIONARY POSITION**

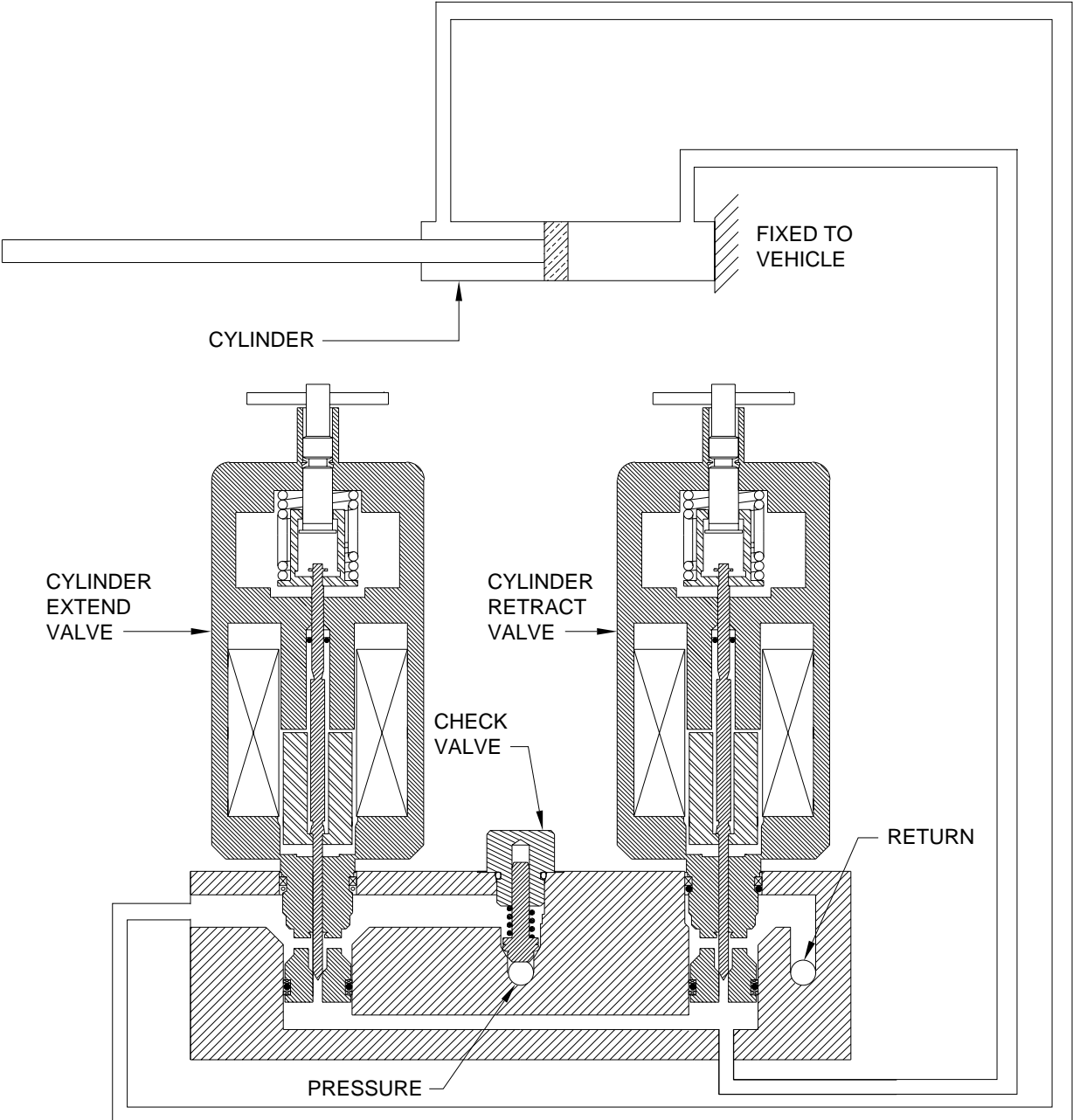

AIR LINE CONNECTION DIAGRAM FRONT AND DRIVE AXLE

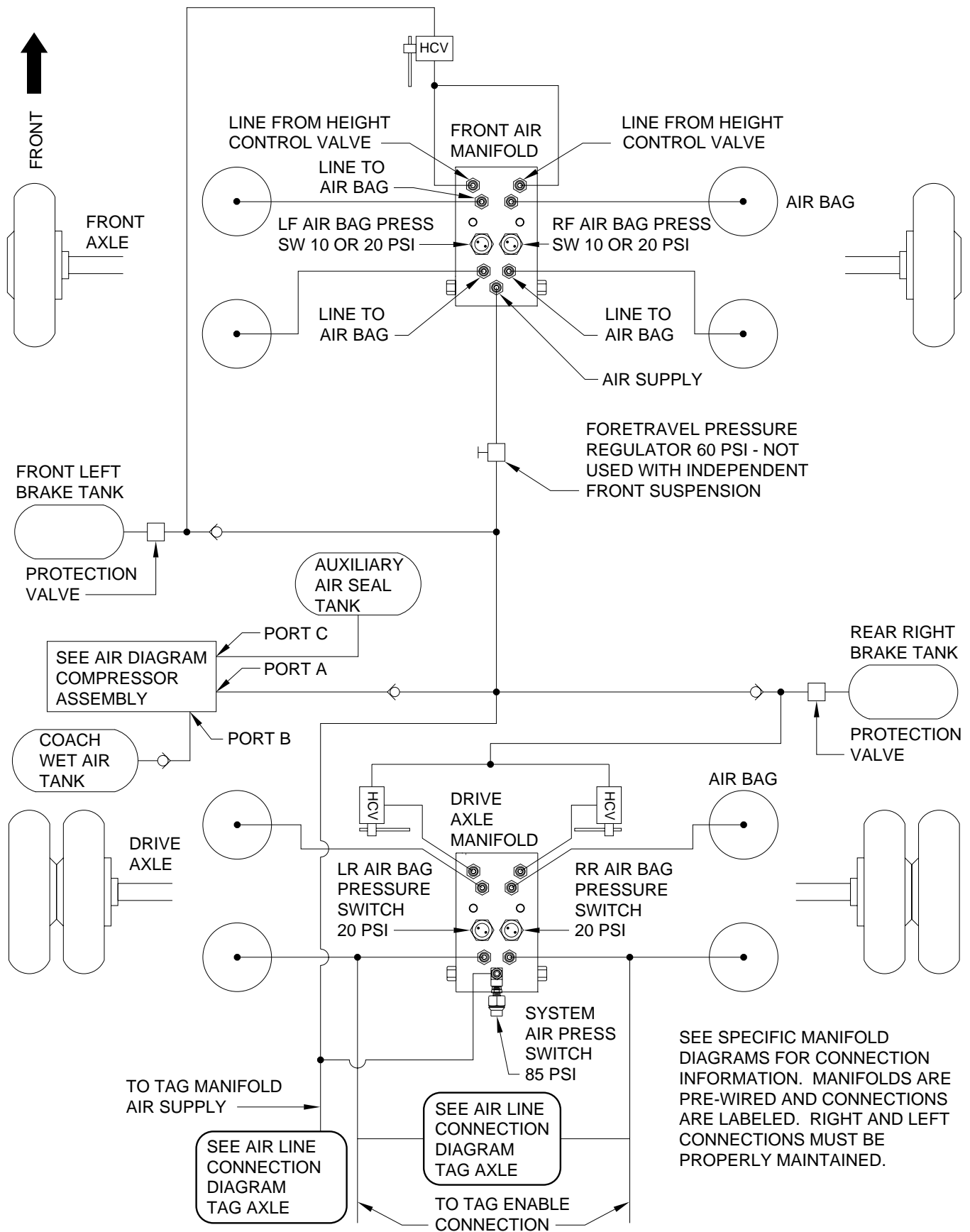

AIR LINE CONNECTION DIAGRAM TAG AXLE

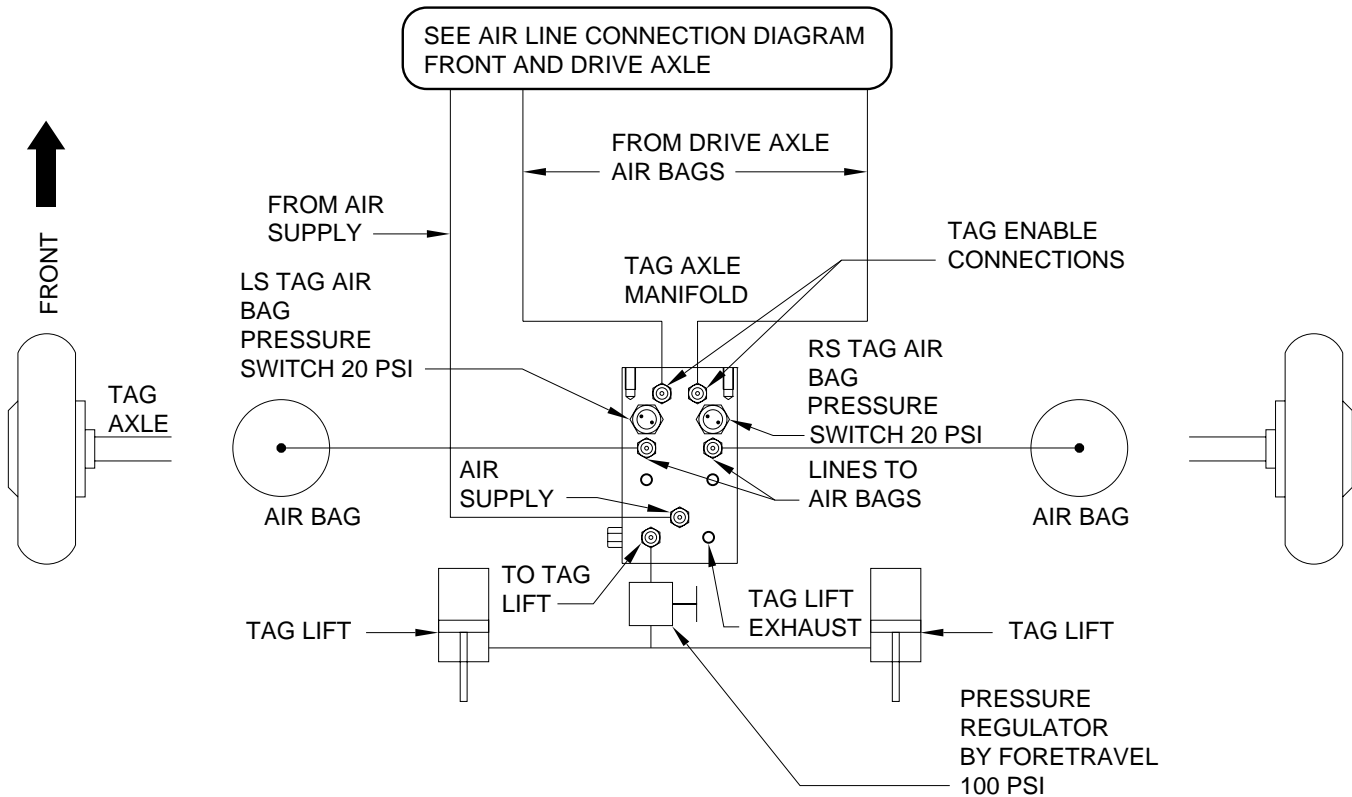

IMPORTANT: MANIFOLDS ARE PRE WIRED AND CONNECTIONS ARE LABELED. RIGHT AND LEFT CONNECTIONS MUST BE PROPERLY MAINTAINED

SEE SPECIFIC MANIFOLD DIAGRAMS FOR CONNECTION INFORMATION

VALVE REPLACEMENT NOTE: THE TAG DUMP/LOWER AIR SOLENOID VALVES ARE A DIFFERENT VALVE THAN THE OTHER VALVES ON THE MANIFOLD. ALL OTHER AIR SOLENOID VALVES ON THE FRONT, DRIVE AND TAG MANIFOLD ASSEMBLIES ARE THE SAME.

AIR LEVEL SCHEMATIC - FORETRAVEL

4 - POINT LEVELING WITH TAG AXLE

PRESSURE SWITCHES FRONT AND DRIVE AXLE

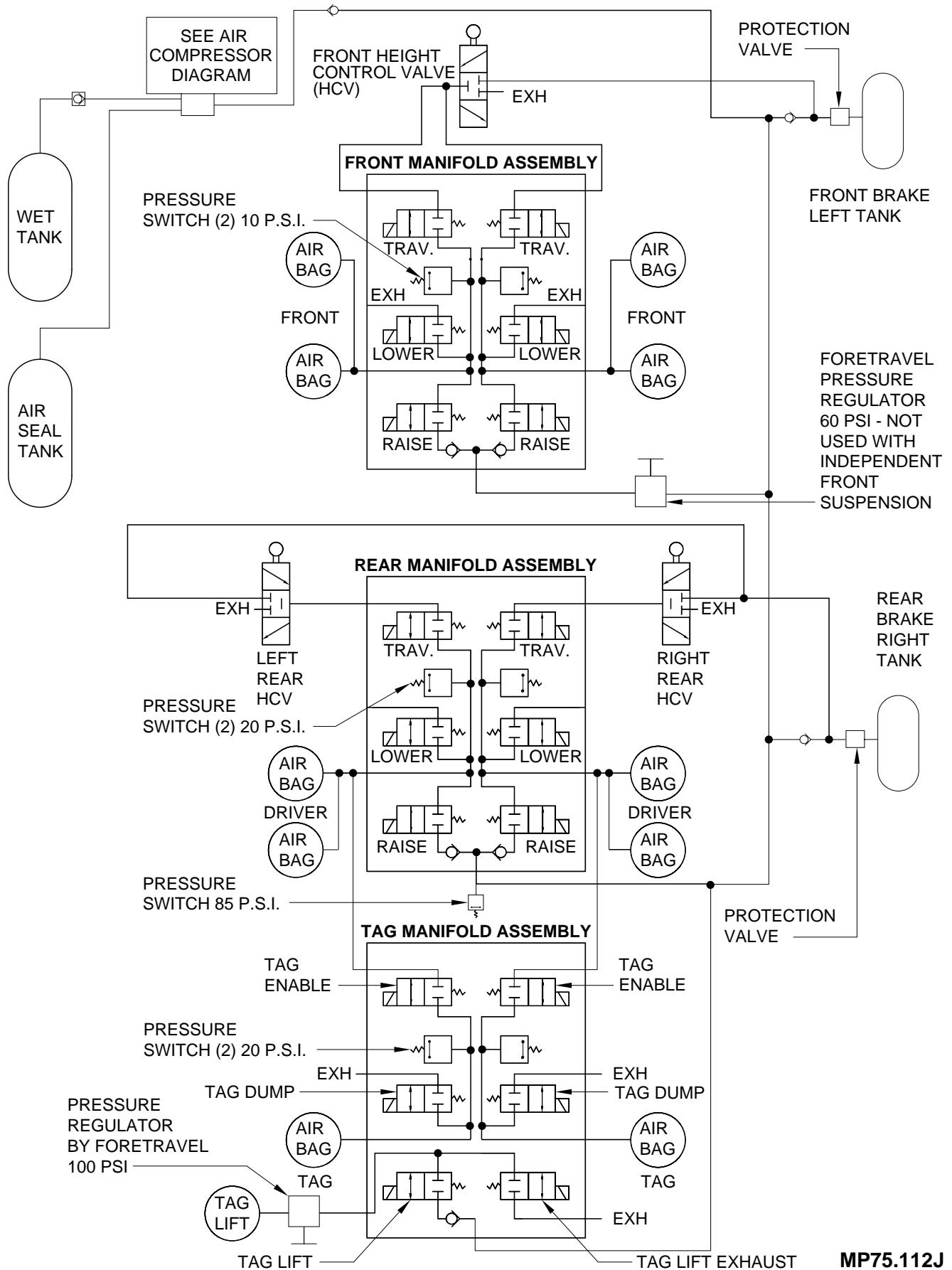

REAR AIR SOLENOID MANIFOLD CONNECTIONS

6 VALVE WITH THREE PRESSURE SWITCHES

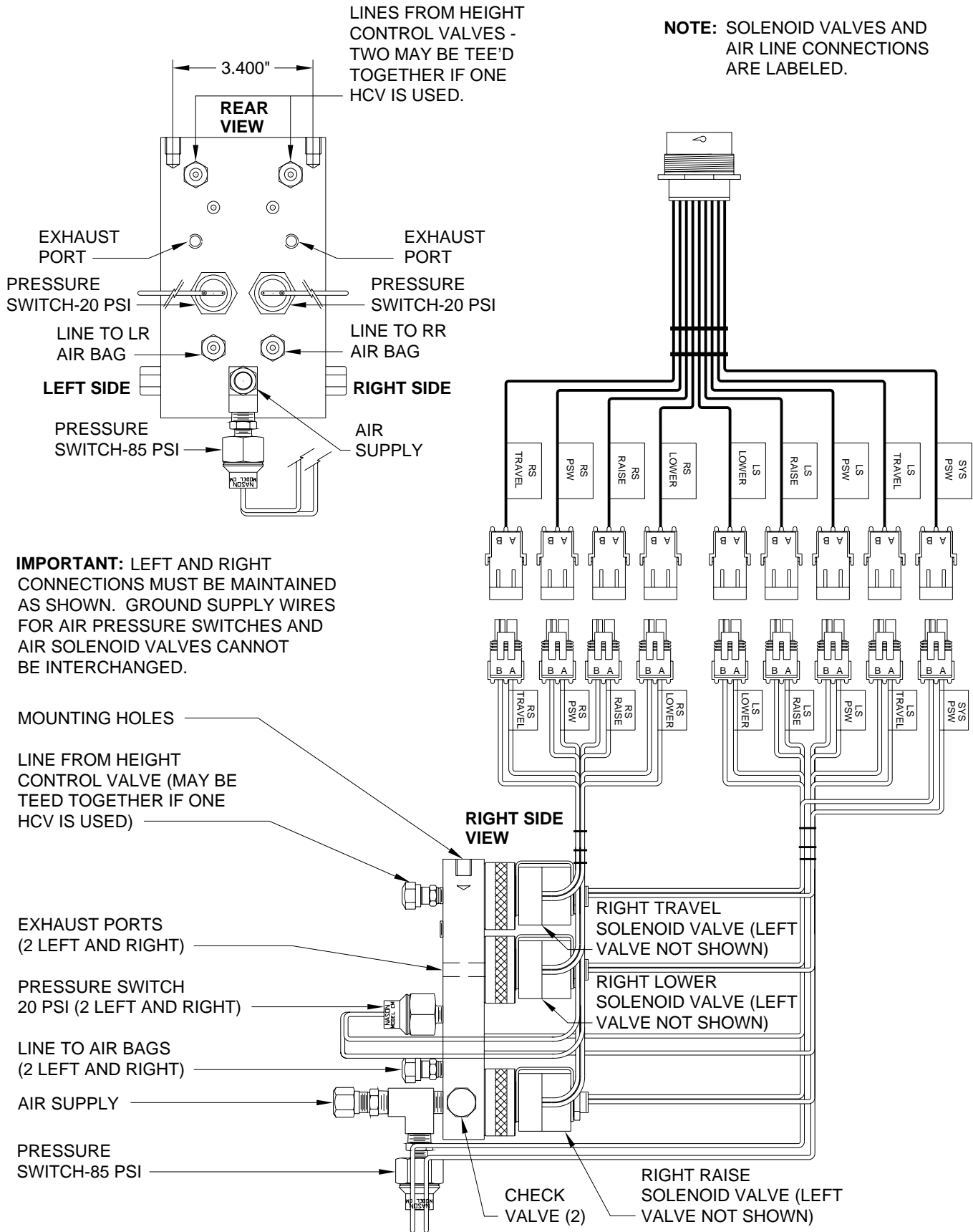

TAG AIR SOLENOID MANIFOLD CONNECTIONS

6 VALVE WITH TWO PRESSURE SWITCHES

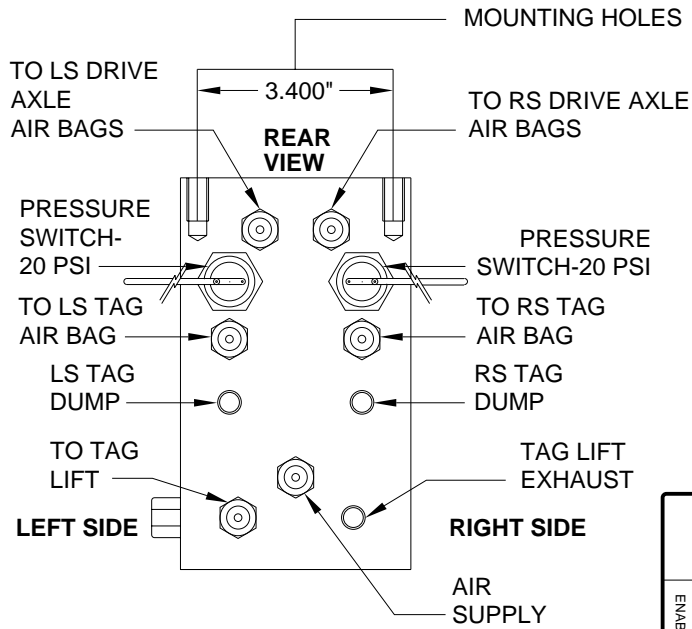

NOTE: SOLENOID VALVES AND AIR LINE CONNECTIONS ARE LABELED.

NOTE: PRESSURE SWITCHES ON TAG AXLE MANIFOLD ARE NOT USED ON ALL SYSTEMS.

IMPORTANT: LEFT AND RIGHT CONNECTIONS MUST BE MAINTAINED AS SHOWN. GROUND SUPPLY WIRES FOR AIR PRESSURE SWITCHES AND AIR SOLENOID VALVES CANNOT BE INTERCHANGED.

NOTE: THE TWO TAG DUMP SOLENOID VALVES ARE A DIFFERENT VALVE THEN THE OTHER FOUR VALVES ON THE MANIFOLD. MAKE SURE THE CORRECT VALVE IS OBTAINED FOR REPLACEMENT.

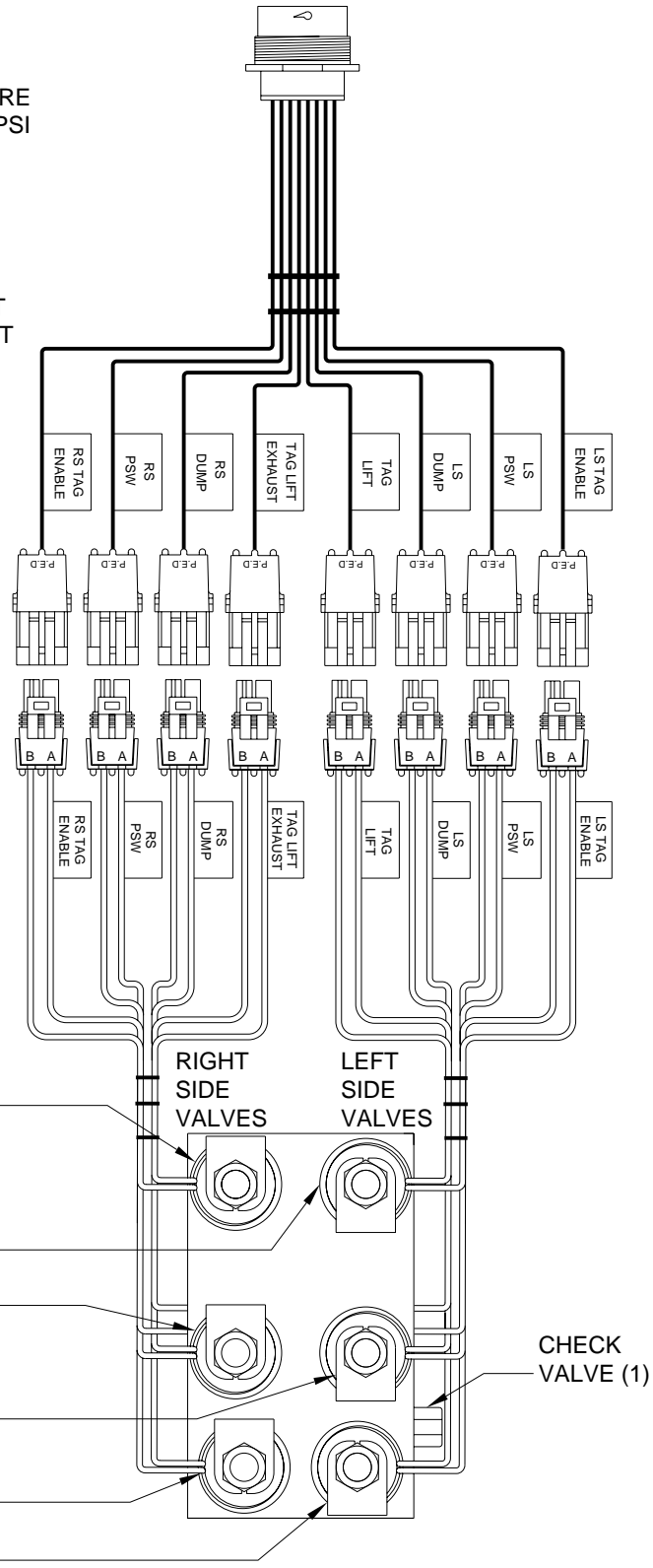

RIGHT SIDE TAG ENABLE SOLENOID VALVE

LEFT SIDE TAG ENABLE SOLENOID VALVE

RIGHT SIDE TAG DUMP SOLENOID VALVE

LEFT SIDE TAG DUMP SOLENOID VALVE

TAG LIFT EXHAUST SOLENOID VALVE

TAG LIFT SOLENOID VALVE

AIR CONNECTION DIAGRAM AUXILIARY COMPRESSOR

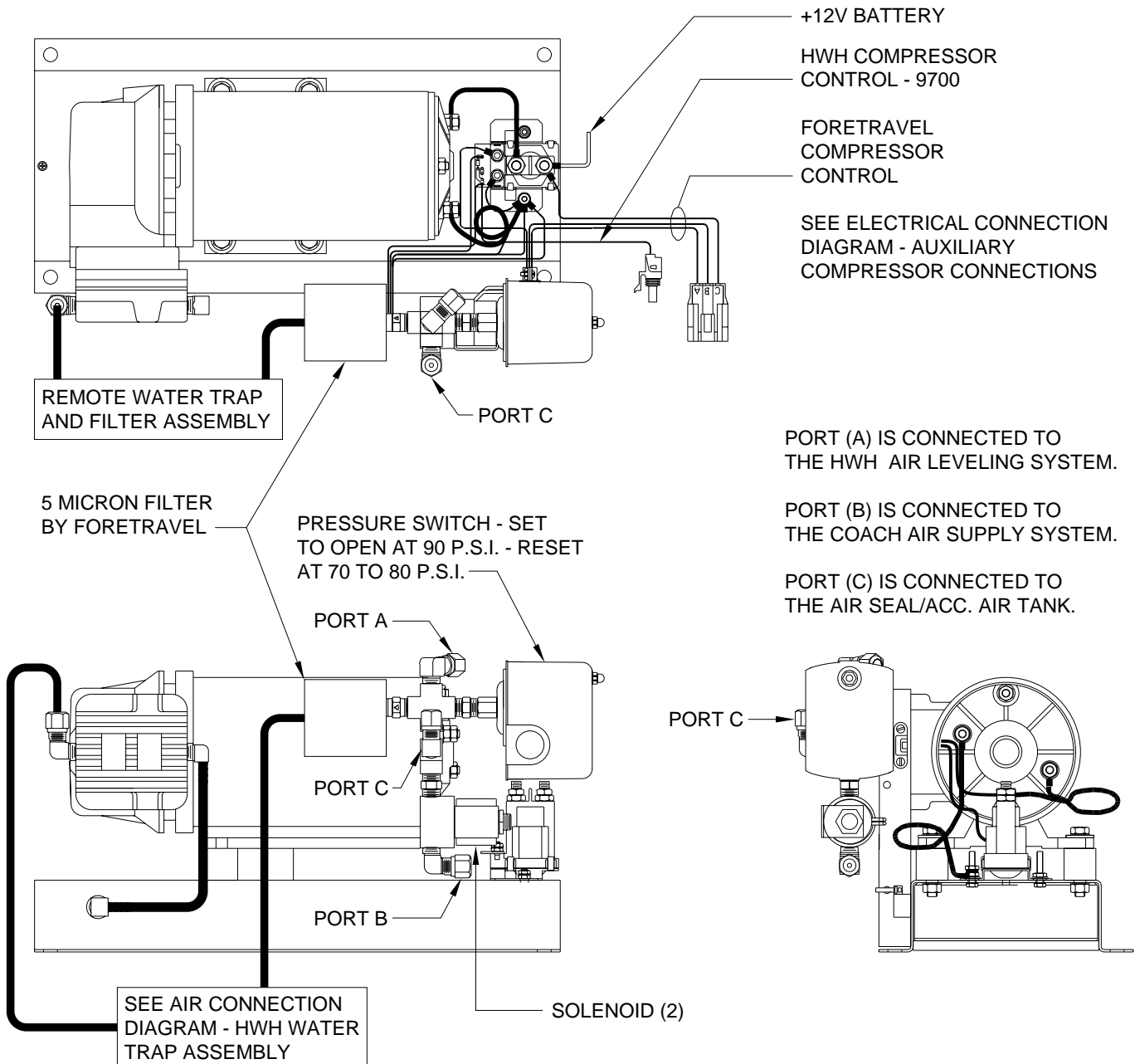

SOLENOID (2) OPENS WHEN THE FORETRAVEL DASH SWITCH IS ON. THE AIR COMPRESSOR RUNS IF THE PRESSURE SWITCH HAS RESET (COACH AIR BELOW 70 - 80 P.S.I.). THIS MAINTAINS COACH AIR SUPPLY AT APPROXIMATELY 90 P.S.I. IF THE VEHICLE IS EQUIPPED WITH AN AIR AWNING THE COACH AIR SUPPLY WILL BE MAINTAINED AT 110 P.S.I.

THE AIR COMPRESSOR RUNS WHENEVER THE PRESSURE SWITCH RESETS (AIR SEAL/ACC. TANK BELOW 70 - 80 P.S.I.). THIS MAINTAINS THE AIR SEAL/ACC. TANK AT APPROXIMATELY 90 P.S.I.

AIR LINE CONNECTION DIAGRAM

HWH WATER TRAP ASSEMBLY

THE WATER TRAP ASSEMBLY IS MOUNTED REMOTE FROM THE AUXILIARY COMPRESSOR ASSEMBLY

AIR SUPPLY FROM
AUXILIARY
COMPRESSOR

TOP VIEW

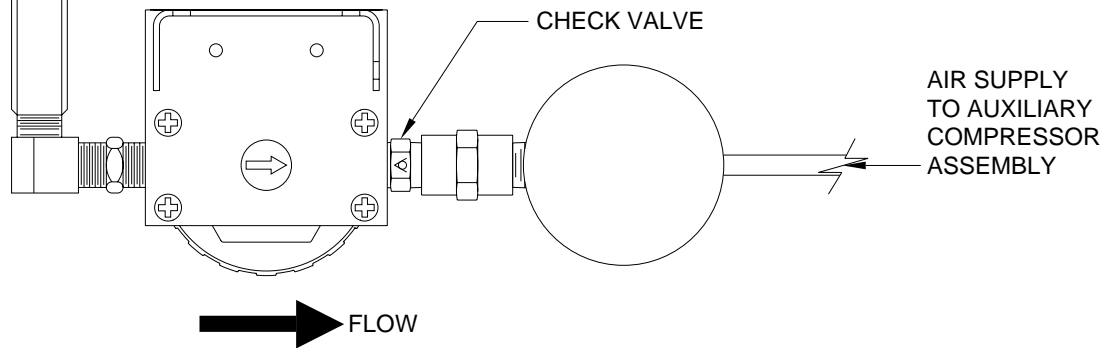

SIDE VIEW

ADJUSTABLE
RELIEF VALVE
SET AT 130 PSI

SOLENOID (1) IS THE WATER
TRAP DUMP VALVE. THIS
VALVE IS CLOSED WHENEVER
THE COMPRESSOR IS RUNNING.

SOLENOID (1)
NORMALLY OPEN
+12 VOLT SOLENOID
VALVE

DESICCANT
FILTER
SUPPLIED BY
FORETRAVEL

REFER TO
FORETRAVEL
FOR
INFORMATION

SEE ELECTRICAL CONNECTION
DIAGRAM - AUXILIARY COMPRESSOR
CONNECTIONS FOR ELECTRICAL
CONNECTION INFORMATION.

AIR CONNECTION DIAGRAM AIR COMPRESSOR SCHEMATIC

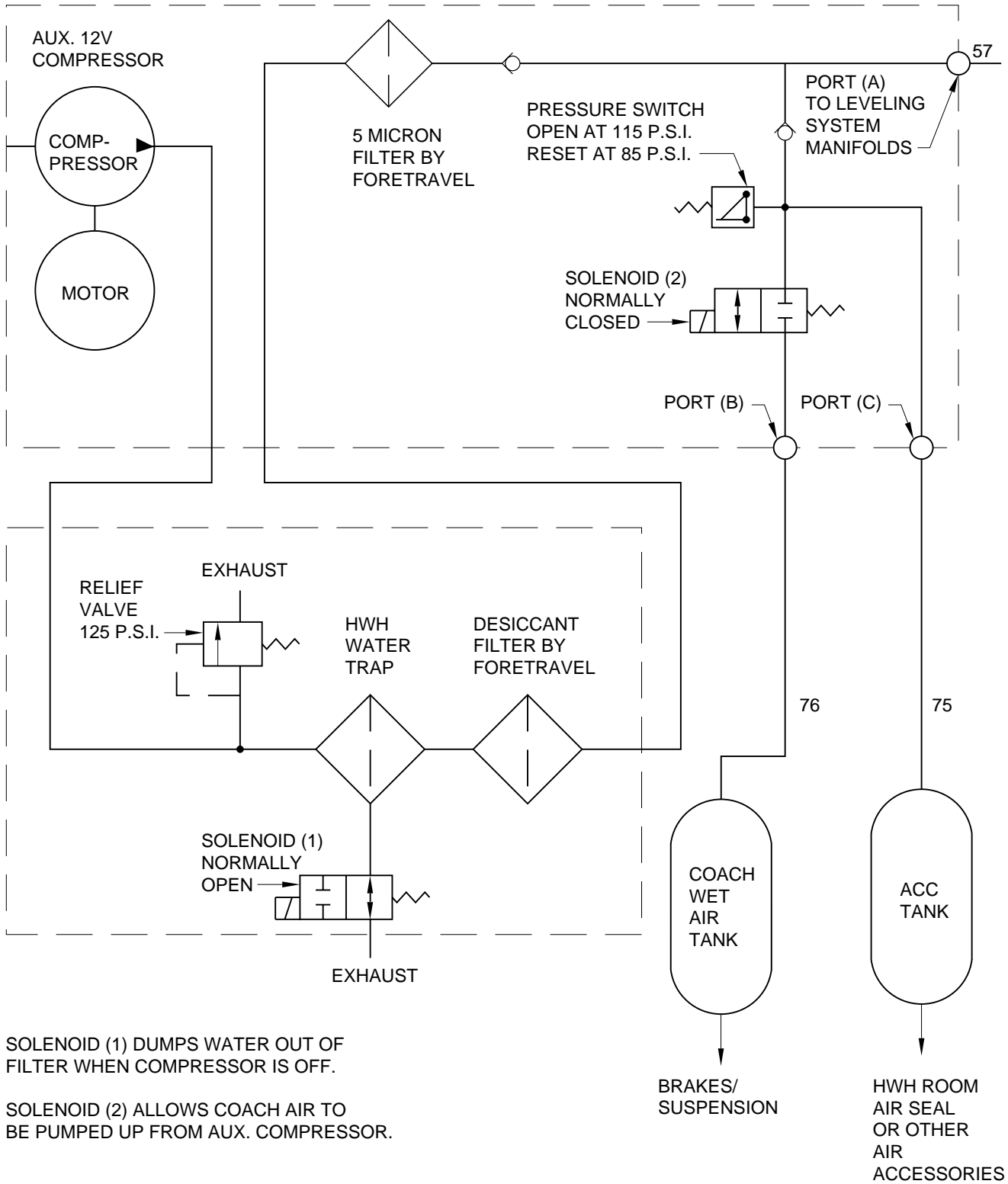

AIR SEAL CONNECTION DIAGRAM

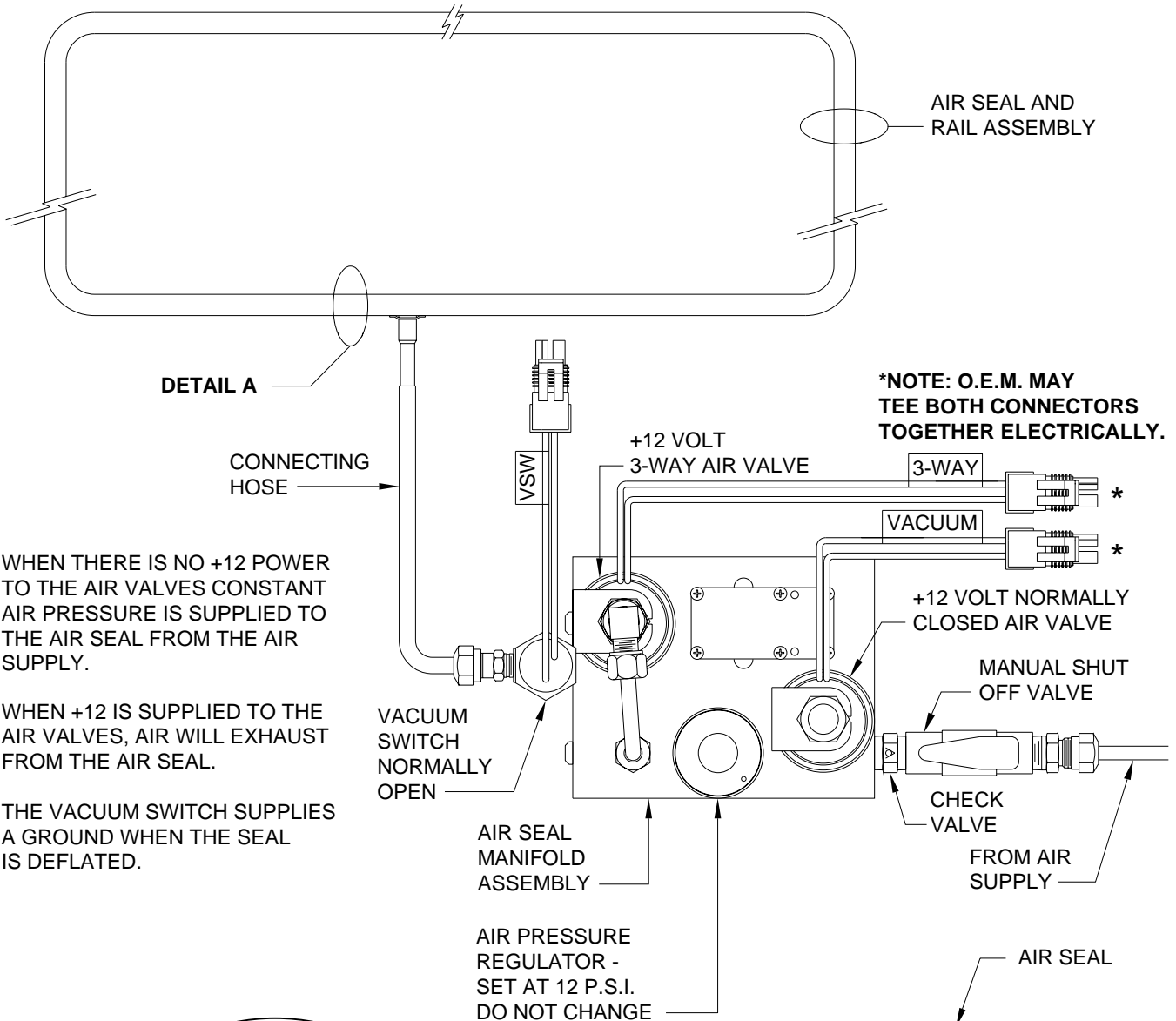

WHEN THERE IS NO +12 POWER TO THE AIR VALVES CONSTANT AIR PRESSURE IS SUPPLIED TO THE AIR SEAL FROM THE AIR SUPPLY.

WHEN +12 IS SUPPLIED TO THE AIR VALVES, AIR WILL EXHAUST FROM THE AIR SEAL.

THE VACUUM SWITCH SUPPLIES A GROUND WHEN THE SEAL IS DEFLATED.



DETAIL A

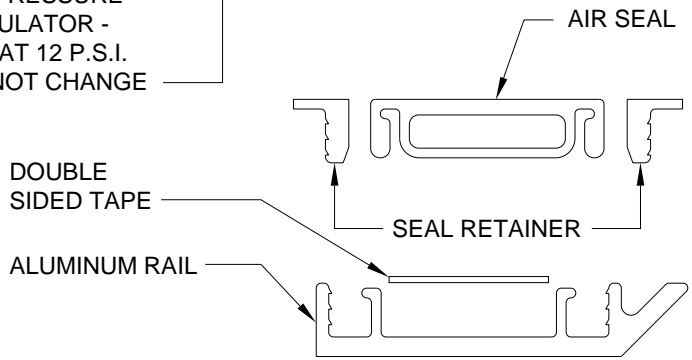

EXPLODED VIEW

ELECTRICAL CONNECTION DIAGRAM CENTRAL CONTROL MODULE

PAGE 1 OF 6

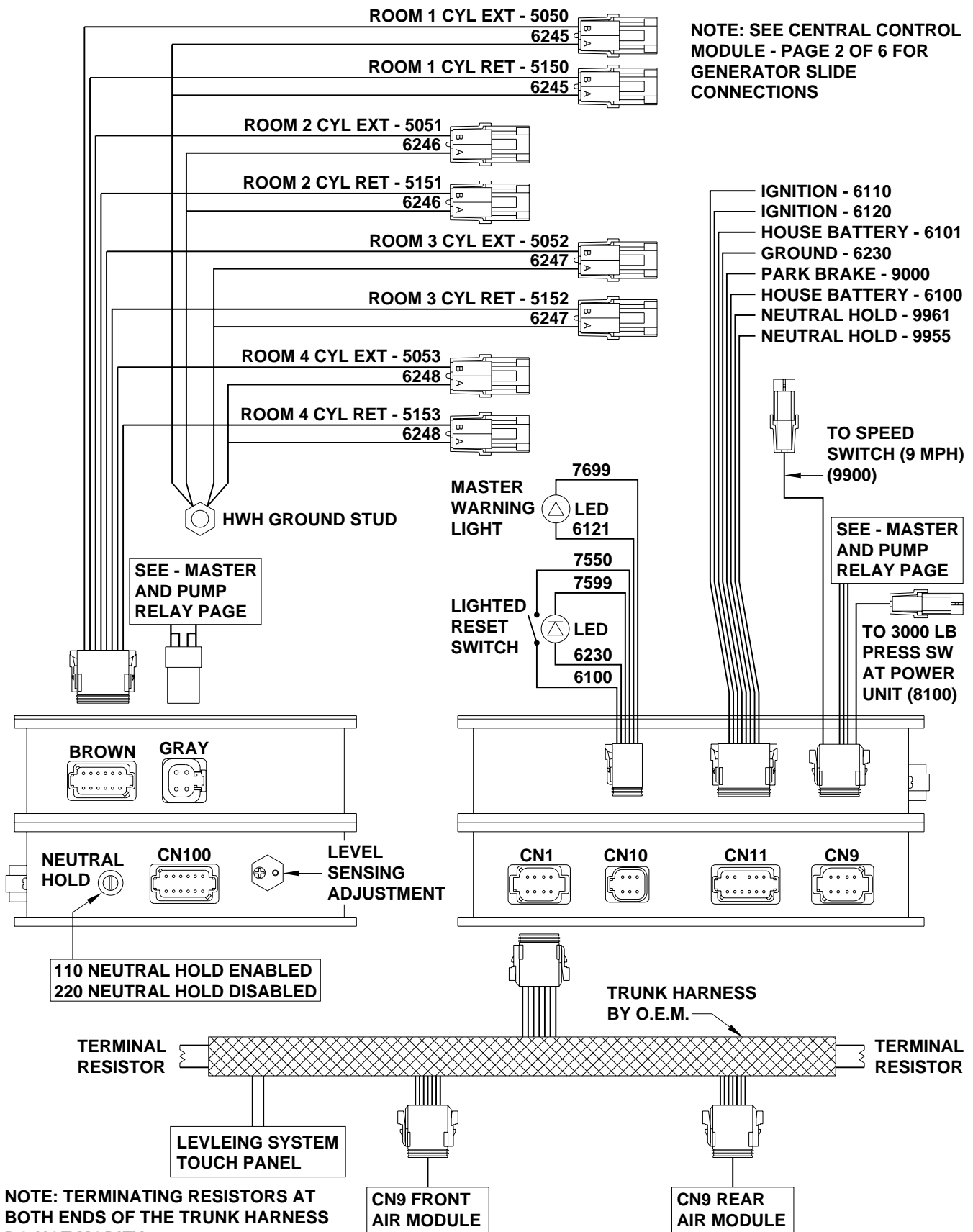

NOTE: TERMINATING RESISTORS AT BOTH ENDS OF THE TRUNK HARNESS DO NOT MODIFY

NOTE: FOR MODULE CONNECTION PIN AND WIRE INFORMATION - SEE CENTRAL CONTROL MODULE PAGES 3 AND 4

MP85.002N
15MAY06

ELECTRICAL CONNECTION DIAGRAM CENTRAL CONTROL MODULE

PAGE 2 OF 6

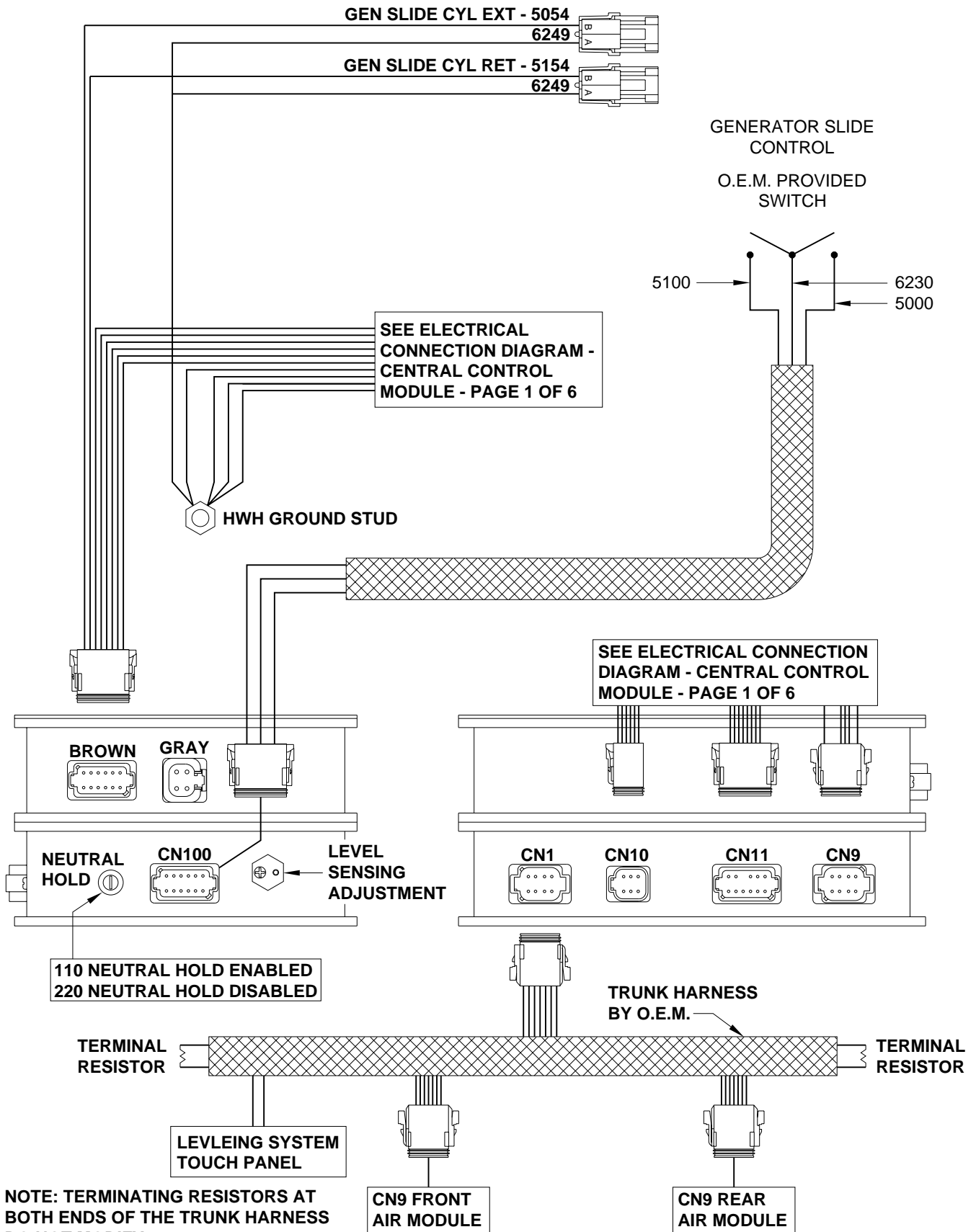

NOTE: TERMINATING RESISTORS AT BOTH ENDS OF THE TRUNK HARNESS DO NOT MODIFY

NOTE: FOR MODULE CONNECTION PIN AND WIRE INFORMATION - SEE CENTRAL CONTROL MODULE PAGES 3 AND 4

**MP85.003N
15MAY06**

ELECTRICAL CONNECTION DIAGRAM CENTRAL CONTROL MODULE

PAGE 3 OF 6

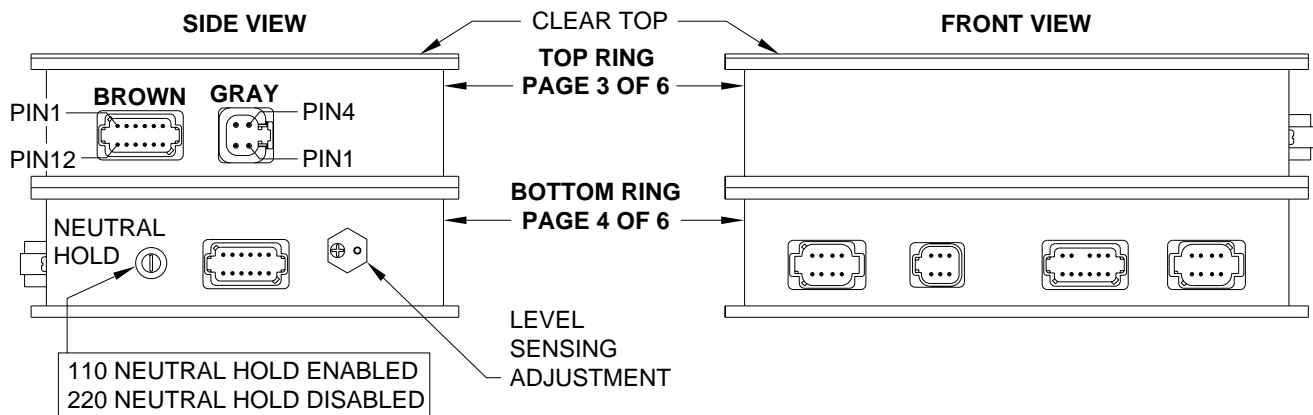

PIN #	WIRE COLOR	WIRE NUMBER	WIRE DESCRIPTION AND FUNCTION
BROWN			12 PIN BROWN CONNECTOR
1	BLACK	5050	ROOM 1 CYLINDER EXTEND SOLENOID VALVE SWITCHED +12
2	BLACK	5150	ROOM 1 CYLINDER RETRACT SOLENOID VALVE SWITCHED +12
3	BLACK	5051	ROOM 2 CYLINDER EXTEND SOLENOID VALVE SWITCHED +12
4	BLACK	5151	ROOM 2 CYLINDER RETRACT SOLENOID VALVE SWITCHED +12
5	BLACK	5052	ROOM 3 CYLINDER EXTEND SOLENOID VALVE SWITCHED +12
6	BLACK	5152	ROOM 3 CYLINDER RETRACT SOLENOID VALVE SWITCHED +12
7	BLACK	5054	CYLINDER EXTEND GEN SLIDE
8	BLACK	5154	CYLINDER RETRACT GEN SLIDE
9	BLACK	5053	ROOM 4 CYLINDER EXTEND SOLENOID VALVE SWITCHED +12
10	BLACK	5153	ROOM 4 CYLINDER RETRACT SOLENOID VALVE SWITCHED +12
11	WHITE	6230	GROUND FOR ROOM 1 AIR MANIFOLD
12			NO CONNECTION
GRAY			4 PIN GRAY CONNECTOR
1	O.E.M.	6800	SWITCHED +12 FROM MASTER RELAY
2	O.E.M.	6800	SWITCHED +12 FROM MASTER RELAY
3	O.E.M.	6230	GROUND FROM GROUND STUD
4	O.E.M.	6230	GROUND FROM GROUND STUD

ELECTRICAL CONNECTION DIAGRAM CENTRAL CONTROL MODULE

PAGE 4 OF 6

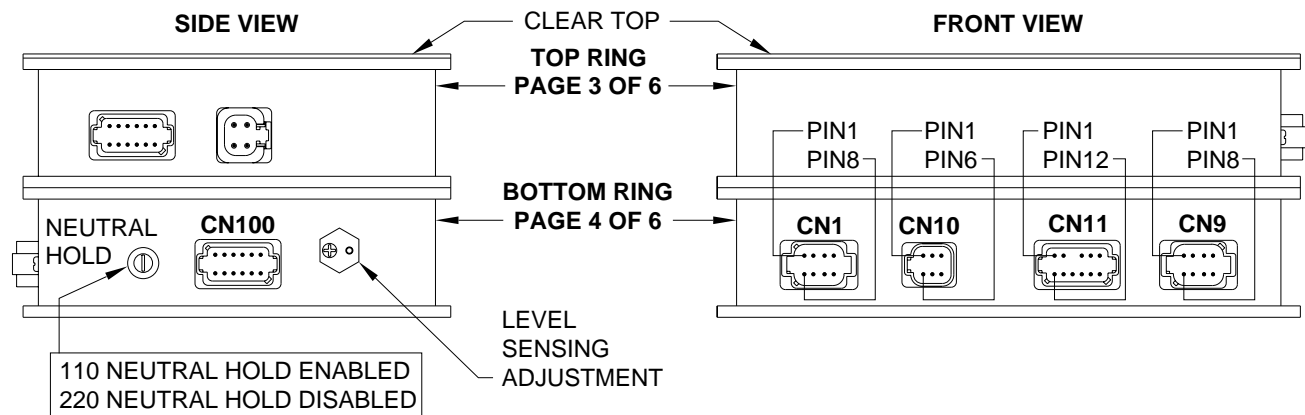

PIN #	WIRE COLOR	WIRE NUMBER	WIRE DESCRIPTION AND FUNCTION
CN1			8 PIN BLACK CONNECTOR
1	O.E.M.	7696	SYSTEM WAKE UP SWITCHED GROUND
2			NO CONNECTION
3	O.E.M.	6800	SWITCHED +12 BATTERY
4	O.E.M.	6230	GROUND TO TOUCH PANEL
5			SHIELD WIRE FOR CAN CABLE
6	O.E.M.	6110	SWITCHED +12 FROM IGNITION
7	O.E.M.		CAN DATA LINE LOW-DO NOT MODIFY
8	O.E.M.		CAN DATA LINE HIGH-DO NOT MODIFY
CN10			6 PIN GRAY CONNECTOR
1	BLACK	7599	RESET SWITCH LIGHT CONTROL-SWITCHED +12
2	RED	6100	RESET SWITCH SUPPLY +12
3	BLACK	7550	RESET SWITCH OUTPUT +12
4	RED	6121	WARNING LIGHT SUPPLY +12
5	WHITE	6230	RESET SWITCH LIGHT GROUND
6	BLACK	7699	WARNING LIGHT CONTROL - SWITCHED GROUND
CN11			12 PIN GRAY CONNECTOR
1	RED	6110	SWITCHED +12 FROM IGNITION
2 THRU 4			NO CONNECTION (PIN 3 - KEY PIN)
5	RED	6120	SWITCHED +12 FROM IGNITION
6	RED	6100	HOUSE BATTERY +12
7	GREEN	6230	GROUND FOR PROCESSOR FROM GROUND STUD
8	WHITE	9961	NEUTRAL HOLD - GROUND FROM TRANS. ECU
9	WHITE	9955	NEUTRAL HOLD - GROUND TO TRANS. ECU
10			NO CONNECTION
11	WHITE	9000	FROM PARK BRAKE SWITCH - SWITCHED GROUND
12	RED	6101	HOUSE BATTERY +12
CN9			8 PIN GREEN CONNECTOR
1	BLACK	8500	MASTER RELAY CONTROL - SWITCHED +12
2	BLACK	8100	SYSTEM PRESSURE SWITCH-SWITCHED GROUND
3			NO CONNECTION
4	BLACK	8600	PUMP RELAY CONTROL - SWITCHED +12
5	BLACK	9900	SPEED SWITCH +12 WITH IGNITION ON BELOW 9 MPH
6	BLACK	9901	PUMP MONITOR-SWITCHED +12 FROM PUMP RELAY
7 AND 8			NO CONNECTION
CN100			12 PIN GRAY CONNECTOR
1	BLACK	5000	GROUND FROM GEN SLIDE SWITCH - EXTEND
2 THRU 5			NO CONNECTION
6	WHITE	6230	GROUND FOR GEN SLIDE SWITCH
7 THRU 11			NO CONNECTION
12	BLACK	5100	GROUND FROM GEN SLIDE SWITCH - RETRACT

**ELECTRICAL CONNECTION DIAGRAM
LED - FUSE LOCATION AND DESCRIPTION
CENTRAL CONTROL MODULE (TOP RING)
PAGE 5 OF 6**

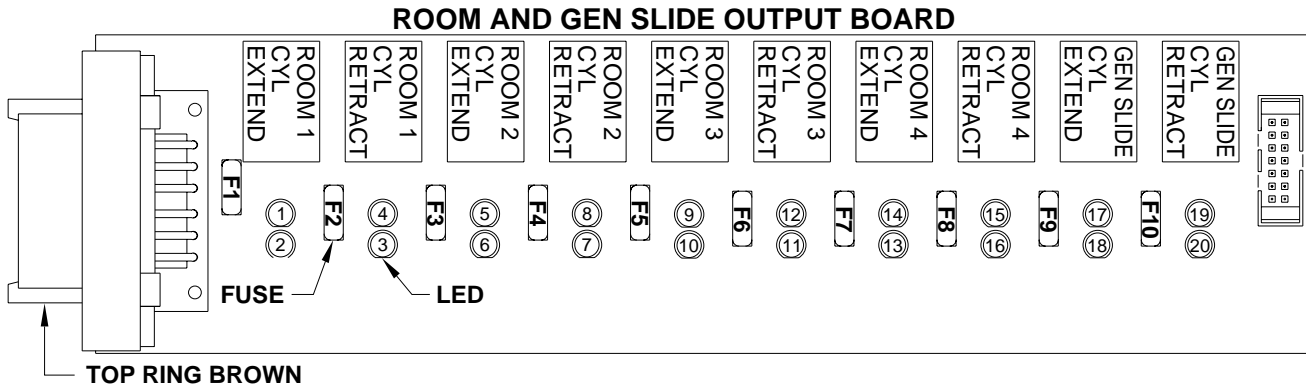

LED	RELAY DESCRIPTION	FUSE	BROWN
1-YELLOW	ROOM 1 CYL EXTEND		
2-RED	ROOM 1 CYL EXTEND	F1 - 15AMP	PIN1
3-RED	ROOM 1 CYL RETRACT	F2 - 15AMP	PIN2
4-YELLOW	ROOM 1 CYL RETRACT		
5-YELLOW	ROOM 2 CYL EXTEND		
6-RED	ROOM 2 CYL EXTEND	F3 - 15AMP	PIN3
7-RED	ROOM 2 CYL RETRACT	F4 - 15AMP	PIN4
8-YELLOW	ROOM 2 CYL RETRACT		
9-YELLOW	ROOM 3 CYL EXTEND		
10-RED	ROOM 3 CYL EXTEND	F5 - 15AMP	PIN5
11-RED	ROOM 3 CYL RETRACT	F6 - 15AMP	PIN6
12-YELLOW	ROOM 3 CYL RETRACT		
13-RED	ROOM 4 CYL EXTEND	F7 - 15AMP	PIN10
14-YELLOW	ROOM 4 CYL EXTEND		
15-YELLOW	ROOM 4 CYL RETRACT		
16-RED	ROOM 4 CYL RETRACT	F8 - 15AMP	PIN9
17-YELLOW	GEN SLIDE CYL EXTEND		
18-RED	GEN SLIDE CYL EXTEND	F9 - 15AMP	PIN7
19-YELLOW	GEN SLIDE CYL RETRACT		
20-RED	GEN SLIDE CYL RETRACT	F10 - 15AMP	PIN8

NOTE: FOR DETAILED INPUT / OUTPUT INFORMATION ABOUT PIN CONNECTIONS SEE ELECTRICAL CONNECTION DIAGRAM - CENTRAL CONTROL MODULE PAGE 3 OF 6.

NOTE: A LIT YELLOW LED INDICATES THERE IS A GROUND SIGNAL TO TURN THE CORRESPONDING RELAY ON.

A LIT RED LED INDICATES THERE IS VOLTAGE ON IT'S CORRESPONDING PIN.

IF A YELLOW LED IS LIT AND THE CORRESPONDING RED LED IS OFF, EITHER IT'S FUSE IS BLOWN OR THE RELAY IS BAD.

IF THE YELLOW LEDS ARE WORKING BUT NO RED LED IS COMING ON THERE IS A PROBLEM WITH INPUT VOLTAGE IN THE 4-PIN CONNECTOR ON THE TOP RING.

IF A YELLOW LED IS NOT LIT, THIS INDICATES A PROBLEM WITH A MODULE.

**ELECTRICAL CONNECTION DIAGRAM
LED - FUSE LOCATION AND DESCRIPTION
CENTRAL CONTROL MODULE (BOTTOM RING)
PAGE 6A OF 6 A-B**

CENTRAL CONTROL MOTHER BOARD

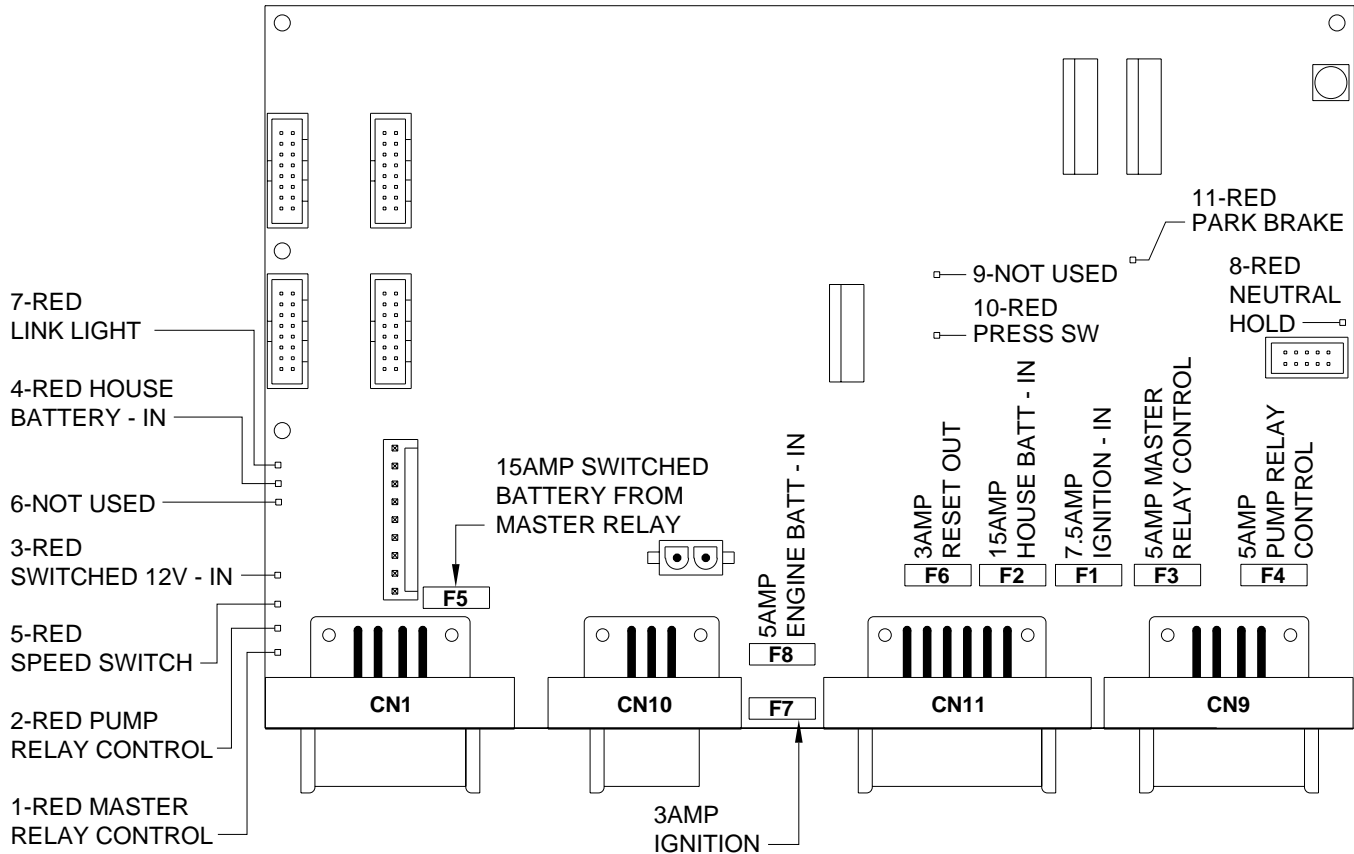

LED	DESCRIPTION	CN AND PIN	FUSE DESCRIPTION
1-RED	MASTER RELAY CONTROL	CN 9 - PIN 1	F1 - 7.5AMP IGNITION - IN
2-RED	PUMP RELAY CONTROL	CN 9 - PIN 4	F2 - 15AMP HOUSE BATTERY - IN
3-RED	SWITCHED 12V FROM MASTER RELAY	CN 1 - PIN 3	F3 - 5AMP MASTER RELAY CONTROL
4-RED	ENGINE BATTERY - IN	CN 11 - PIN 12	F4 - 5AMP PUMP RELAY CONTROL
5-RED	SPEED SWITCH*	CN 9 - PIN 5	F5 - 15AMP SWITCHED BATTERY - IN
6-NOT USED	NOT USED	NOT USED	F6 - 3AMP RESET OUT
7-RED	LINK LIGHT	CN 1 - PIN 7 & 8	F7 - 3AMP IGNITION - IN
8-RED	NEUTRAL HOLD ENABLED**	CN 11 - PIN 8 & 9	F8 - 5AMP HOUSE BATTERY - IN
9-NOT USED	NOT USED	NOT USED	
10-RED	3000 LBS PRESS SWITCH - ON	CN 9 - PIN 2	
11-RED	PARK PRAKE - ON	CN 11 - PIN 11	

NOTE: FOR DETAILED INPUT / OUTPUT INFORMATION ABOUT PIN CONNECTIONS SEE ELECTRICAL CONNECTION DIAGRAM - CENTRAL CONTROL - ROOM 1 MODULE CONNECTION INFORMATION - PAGE 3 OF 5.

* LED 5 INDICATES A +12 SIGNAL FROM THE SPEED SWITCH - IGNITION ON COACH SPEED LESS THAN 10 MPH
 ** LED 8 INDICATES TRANSMISSION IS DISABLED WHEN LIT.

**ELECTRICAL CONNECTION DIAGRAM
LED - FUSE LOCATION AND DESCRIPTION
CENTRAL CONTROL MODULE (BOTTOM RING)
PAGE 6B OF 6 A-B**

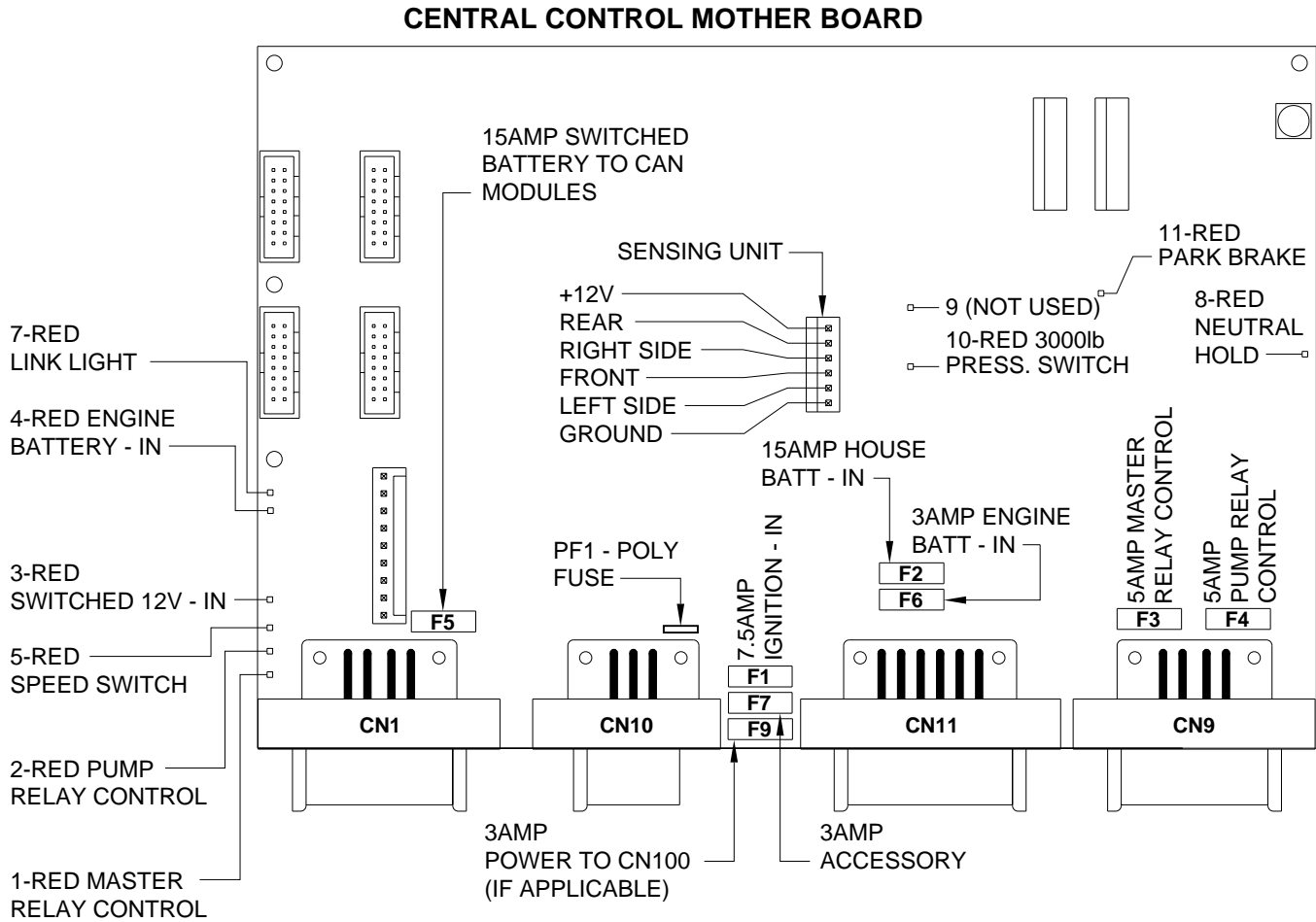

LED	DESCRIPTION	CN AND PIN	FUSE DESCRIPTION
1-RED	MASTER RELAY CONTROL	CN 9 - PIN 1	PF1 - POLY FUSE - POWER TO MASTER WARNING LIGHT AND RESET SWITCH F1 - 7.5AMP IGNITION - IN F2 - 15AMP HOUSE BATTERY - IN F3 - 5AMP MASTER RELAY CONTROL F4 - 5AMP PUMP RELAY CONTROL F5 - 15AMP SWITCHED BATTERY - IN F6 - 3AMP RESET OUT F7 - 3AMP ACCESSORY - IN F9 - 3AMP POWER TO CN100 (IF APPLICABLE)
2-RED	PUMP RELAY CONTROL	CN 9 - PIN 4	
3-RED	SWITCHED 12V FROM MASTER RELAY	CN 1 - PIN 3	
4-RED	ENGINE BATTERY - IN	CN 11 - PIN 12	
5-RED	SPEED SWITCH*	CN 9 - PIN 5	
7-RED	LINK LIGHT	CN 1 - PIN 7 & 8	
8-RED	NEUTRAL HOLD**	CN 11 - PIN 8 & 9	
9-NOT USED	NOT USED	NOT USED	
10-RED	3000 LBS PRESS SWITCH - ON	CN 9 - PIN 2	
11-RED	PARK PRAKE - ON	CN 11 - PIN 11	

NOTE: FOR DETAILED INPUT / OUTPUT INFORMATION ABOUT PIN CONNECTIONS SEE ELECTRICAL CONNECTION DIAGRAM - CENTRAL CONTROL MODULE CONNECTION INFORMATION - PAGE 4 OF 6.

* LED 5 INDICATES A +12 SIGNAL FROM THE SPEED SWITCH - IGNITION ON COACH SPEED LESS THAN 10 MPH
 ** LED 8 INDICATES TRANSMISSION IS DISABLED WHEN LIT.

ELECTRICAL CONNECTION DIAGRAM

FRONT AIR - ROOMS 1 AND 4 MODULE

PAGE 1 OF 6

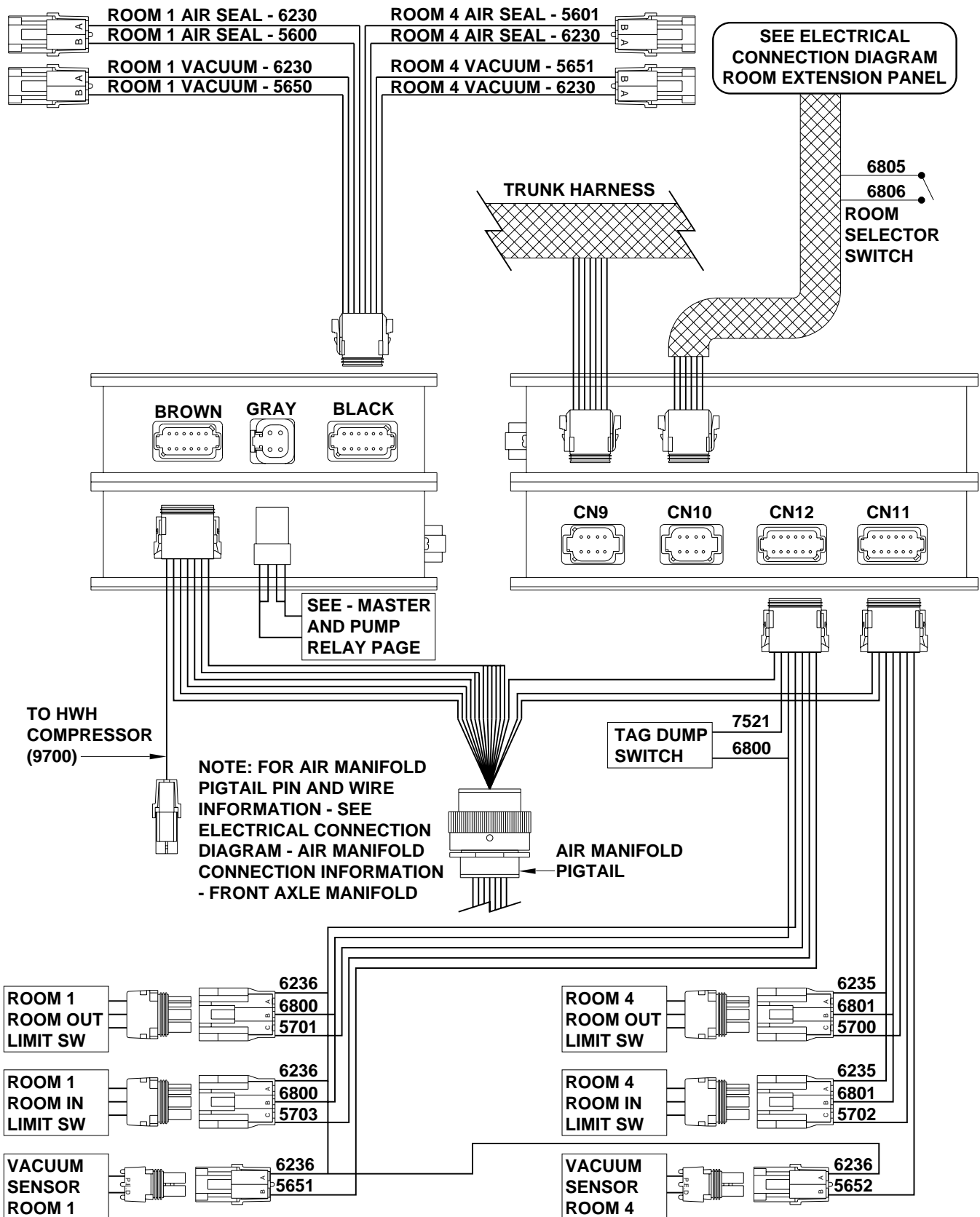

NOTE: FOR MODULE CONNECTION PIN AND WIRE INFORMATION - SEE FRONT AIR MODULE PAGE 2 AND 3 OF 6

ELECTRICAL CONNECTION DIAGRAM

FRONT AIR - ROOMS 1 AND 4 MODULE

PAGE 2 OF 6

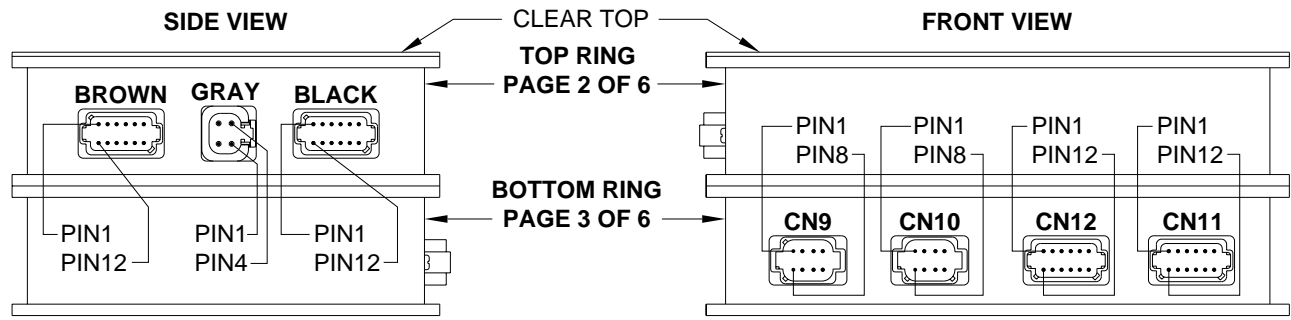

PIN #	WIRE COLOR	WIRE NUMBER	WIRE DESCRIPTION AND FUNCTION
BROWN			12 PIN BROWN CONNECTOR
1			NO CONNECTION
2	BLACK	1500	LEFT FRONT RAISE AIR VALVE CONTROL - SWITCHED +12
3	BLACK	1600	LEFT FRONT LOWER AIR VALVE CONTROL - SWITCHED +12
4	BLACK	2500	RIGHT FRONT RAISE AIR VALVE CONTROL - SWITCHED +12
5	BLACK	2600	RIGHT FRONT LOWER AIR VALVE CONTROL - SWITCHED +12
6	BLACK	9700	AUXILIARY AIR COMPRESSOR CONTROL - SWITCHED +12
7			NO CONNECTION
8	BLACK	1700	FRONT AIR MANIFOLD TRAVEL VALVES CONTROL - SWITCHED +12
9 AND 10			NO CONNECTION
11	WHITE	6254	GROUND FOR AIR SOLENOID VALVES
12			NO CONNECTION
GRAY			4 PIN GRAY CONNECTOR
1	RED	6800	SWITCHED +12 FROM MASTER RELAY
2	RED	6800	SWITCHED +12 FROM MASTER RELAY
3	GREEN	6230	GROUND FROM GROUND STUD - FOR SOLENOID VALVES
4	GREEN	6230	GROUND FROM GROUND STUD - FOR SOLENOID VALVES
BLACK			12 PIN BLACK CONNECTOR
1	BLACK	5650	ROOM 1 AIR SEAL MANIFOLD VACUUM - SWITCHED +12
2	BLACK	5600	ROOM 1 AIR SEAL MANIFOLD - SWITCHED +12
3	BLACK	5651	ROOM 4 AIR SEAL MANIFOLD VACUUM - SWITCHED +12
4	BLACK	5601	ROOM 4 AIR SEAL MANIFOLD - SWITCHED +12
5 THRU 10			NO CONNECTION
11	WHITE	6230	GROUND
12			NO CONNECTION

ELECTRICAL CONNECTION DIAGRAM

FRONT AIR - ROOMS 1 AND 4 MODULE

PAGE 3 OF 6

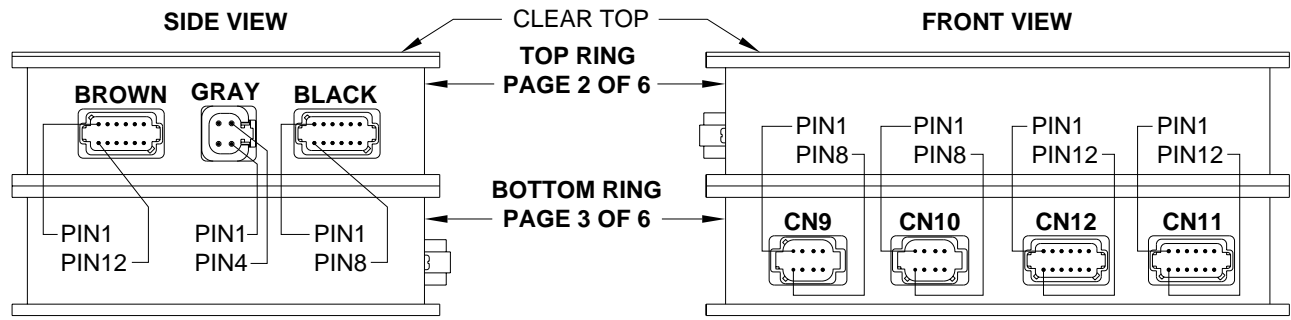

PIN #	WIRE COLOR	WIRE NUMBER	WIRE DESCRIPTION AND FUNCTION
CN9			8 PIN BLACK CONNECTOR
1	WHITE	7696	SYSTEM WAKE UP SWITCHED GROUND
2			NO CONNECTION
3	RED	6800	SWITCHED +12 BATTERY
4	GREEN	6230	GROUND
5			SHIELD WIRE FOR CAN CABLE
6	RED	6110	IGNITION +12
7	GREEN		CAN DATA LINE LOW - DO NOT MODIFY
8	YELLOW		CAN DATA LINE HIGH - DO NOT MODIFY
CN10			NO CONNECTION
1	BLACK	6806	FROM ROOM SELECT SWITCH - SWITCHED +12 FOR ROOM 4
2	WHITE	7510	READY TO OPERATE LIGHT CONTROL - SWITCHED +12
3	WHITE	7530	PUMP ON LIGHT CONTROL - SWITCHED +12
4	WHITE	7501	ROOM EXTEND - SWITCHED +12 - ROOM 1 AND 4
5	WHITE	7502	ROOM RETRACT - SWITCHED +12 - ROOM 1 AND 4
6	RED	6805	SWITCHED +12 BATTERY TO ROOM PANEL KEY SWITCH
7	WHITE	7696	SYSTEM WAKE UP - SWITCHED GROUND
8	GREEN	6230	GROUND TO ROOM PANEL KEY SWITCH
CN12			12 PIN GRAY CONNECTOR
1			NO CONNECTION
2	BLACK	5701	FROM ROOM 1 - ROOM OUT LIMIT SWITCH - SWITCHED GROUND
3	BLACK	5703	FROM ROOM 1 - ROOM IN LIMIT SWITCH - SWITCHED GROUND
4 AND 5			NO CONNECTION
6	WHITE	6236	GROUND
7	BLACK	6800	SWITCHED +12 BATTERY
8	BLACK	5651	FROM ROOM 1 VACUUM SENSOR - SWITCHED GROUND
9			NO CONNECTION
10	BLACK	2210	RIGHT FRONT AIR PRESSURE SWITCH - SWITCHED GROUND
11	BLACK	7521	FROM TAG DUMP SWITCH - SWITCHED +12 TO DUMP
12			NO CONNECTION
CN11			12 PIN GREEN CONNECTOR
1	BLACK	5652	FROM ROOM 4 VACUUM SENSOR - SWITCHED GROUND
2	BLACK	5700	FROM ROOM 4 ROOM OUT LIMIT SWITCH - SWITCHED GROUND
3	BLACK	5702	FROM ROOM 4 - ROOM IN LIMIT SWITCH - SWITCHED GROUND
4 AND 5			NO CONNECTION
6	WHITE	6236	GROUND
7	BLACK	6801	SWITCHED +12 BATTERY
8 AND 9			NO CONNECTION
10	BLACK	1210	LEFT FRONT AIR PRESSURE SWITCH - SWITCHED GROUND
11 AND 12			NO CONNECTION

**ELECTRICAL CONNECTION DIAGRAM
LED - FUSE LOCATION AND DESCRIPTION
FRONT AIR MODULE - ROOMS 1 AND 4
PAGE 4 OF 6**

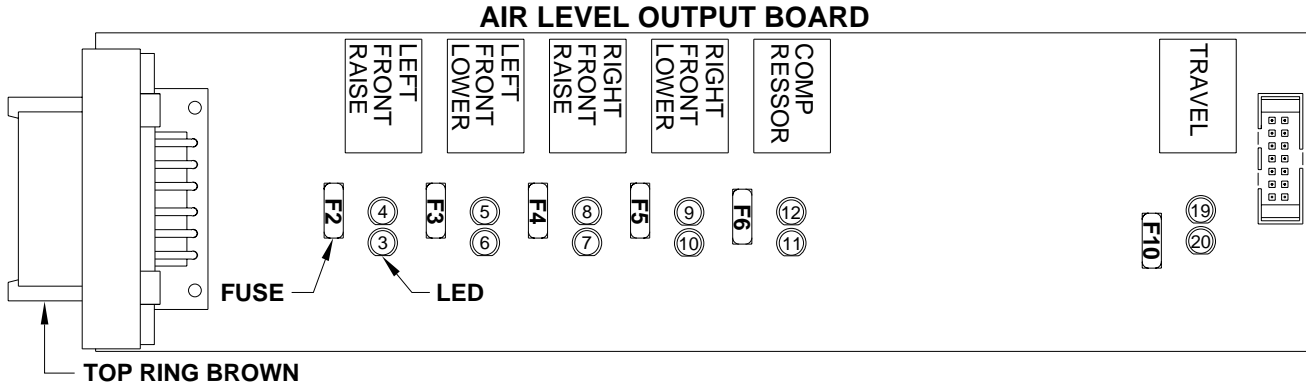

LED	RELAY DESCRIPTION	FUSE	BROWN
3-RED	LEFT FRONT RAISE	F2 - 5 AMP	PIN 2
4-YELLOW	LEFT FRONT RAISE		
5-YELLOW	LEFT FRONT LOWER		
6-RED	LEFT FRONT LOWER	F3 - 5 AMP	PIN 3
7-RED	RIGHT FRONT RAISE	F4 - 5 AMP	PIN 4
8-YELLOW	RIGHT FRONT RAISE		
9-YELLOW	RIGHT FRONT LOWER		
10-RED	RIGHT FRONT LOWER	F5 - 5 AMP	PIN 5
11-RED	COMPRESSOR	F6 - 5 AMP	PIN 6
12-YELLOW	COMPRESSOR		
19-YELLOW	TRAVEL		
20-RED	TRAVEL	F10 - 7.5 AMP	PIN 8

NOTE: THE TRAVEL RELAY IS WIRED AS A NORMALLY CLOSED RELAY. WHEN THE YELLOW LED (19) IS ON THE RELAY CONTACTS WILL OPEN. THE RED LED (20) WILL NOT BE ON. THE RED LED WILL BE ON IF THE LEVELING SYSTEM IS IN THE TRAVEL MODE AND THE IGNITION IS ON.

NOTE: FOR DETAILED INPUT / OUTPUT INFORMATION ABOUT PIN CONNECTIONS SEE ELECTRICAL CONNECTION DIAGRAM - FRONT AIR MODULE PAGE 2 OF 6.

NOTE: A LIT YELLOW LED INDICATES THERE IS A GROUND SIGNAL TO TURN THE CORRESPONDING RELAY ON.

A LIT RED LED INDICATES THERE IS VOLTAGE ON IT'S CORRESPONDING PIN.

IF A YELLOW LED IS LIT AND THE CORRESPONDING RED LED IS OFF, EITHER IT'S FUSE IS BLOWN OR THE RELAY IS BAD.

IF THE YELLOW LEDS ARE WORKING BUT NO RED LED IS COMING ON THERE IS A PROBLEM WITH INPUT VOLTAGE IN THE 4-PIN CONNECTOR ON THE TOP RING.

IF A YELLOW LED IS NOT LIT, THIS INDICATES A PROBLEM WITH A MODULE.

**ELECTRICAL CONNECTION DIAGRAM
LED - FUSE LOCATION AND DESCRIPTION
FRONT AIR - ROOMS 1 AND 4 MODULE
PAGE 5 OF 6**

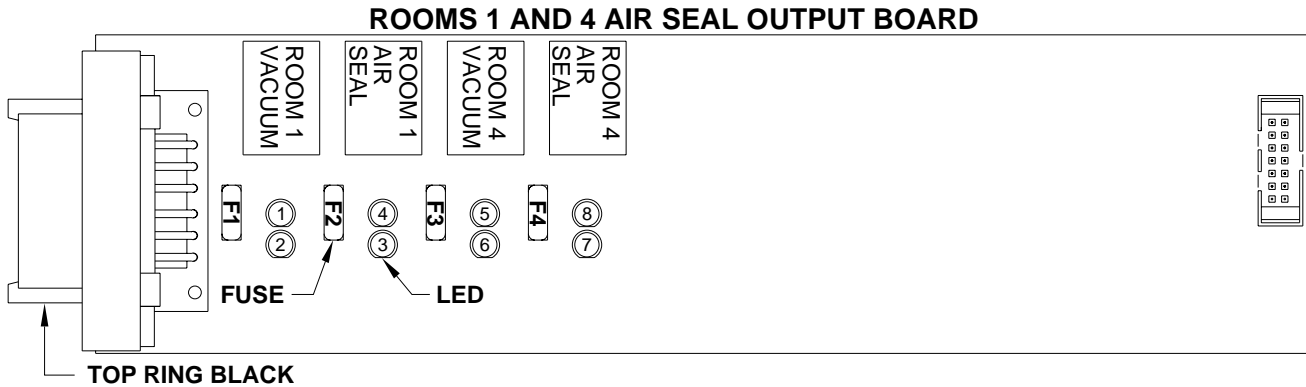

NOTE: FOR DETAILED INPUT / OUTPUT INFORMATION ABOUT PIN CONNECTIONS SEE ELECTRICAL CONNECTION DIAGRAM - FRONT AIR MODULE PAGE 2 OF 6.

NOTE: A LIT YELLOW LED INDICATES THERE IS A GROUND SIGNAL TO TURN THE CORRESPONDING RELAY ON.

A LIT RED LED INDICATES THERE IS VOLTAGE ON IT'S CORRESPONDING PIN.

IF A YELLOW LED IS LIT AND THE CORRESPONDING RED LED IS OFF, EITHER IT'S FUSE IS BLOWN OR THE RELAY IS BAD.

IF THE YELLOW LEDS ARE WORKING BUT NO RED LED IS COMING ON THERE IS A PROBLEM WITH INPUT VOLTAGE IN THE 4-PIN CONNECTOR ON THE TOP RING.

IF A YELLOW LED IS NOT LIT, THIS INDICATES A PROBLEM WITH A MODULE.

LED	RELAY DESCRIPTION	FUSE	BLACK
YELLOW-COIL RED- CONTACTS			
1-YELLOW	ROOM 1 VACUUM		
2-RED	ROOM 1 VACUUM	F1 - 5 AMP	PIN 1
3-RED	ROOM 1 AIR SEAL	F2 - 5 AMP	PIN 2
4-YELLOW	ROOM 1 AIR SEAL		
5-YELLOW	ROOM 4 VACUUM		
6-RED	ROOM 4 VACUUM	F3 - 5 AMP	PIN 3
7-RED	ROOM 4 AIR SEAL	F4 - 5 AMP	PIN 4
8-YELLOW	ROOM 4 AIR SEAL		

ELECTRICAL CONNECTION DIAGRAM

LED - FUSE LOCATION AND DESCRIPTION

FRONT AIR - ROOMS 1 AND 4 MODULE

PAGE 6 OF 6

FRONT AIR I/O BOARD

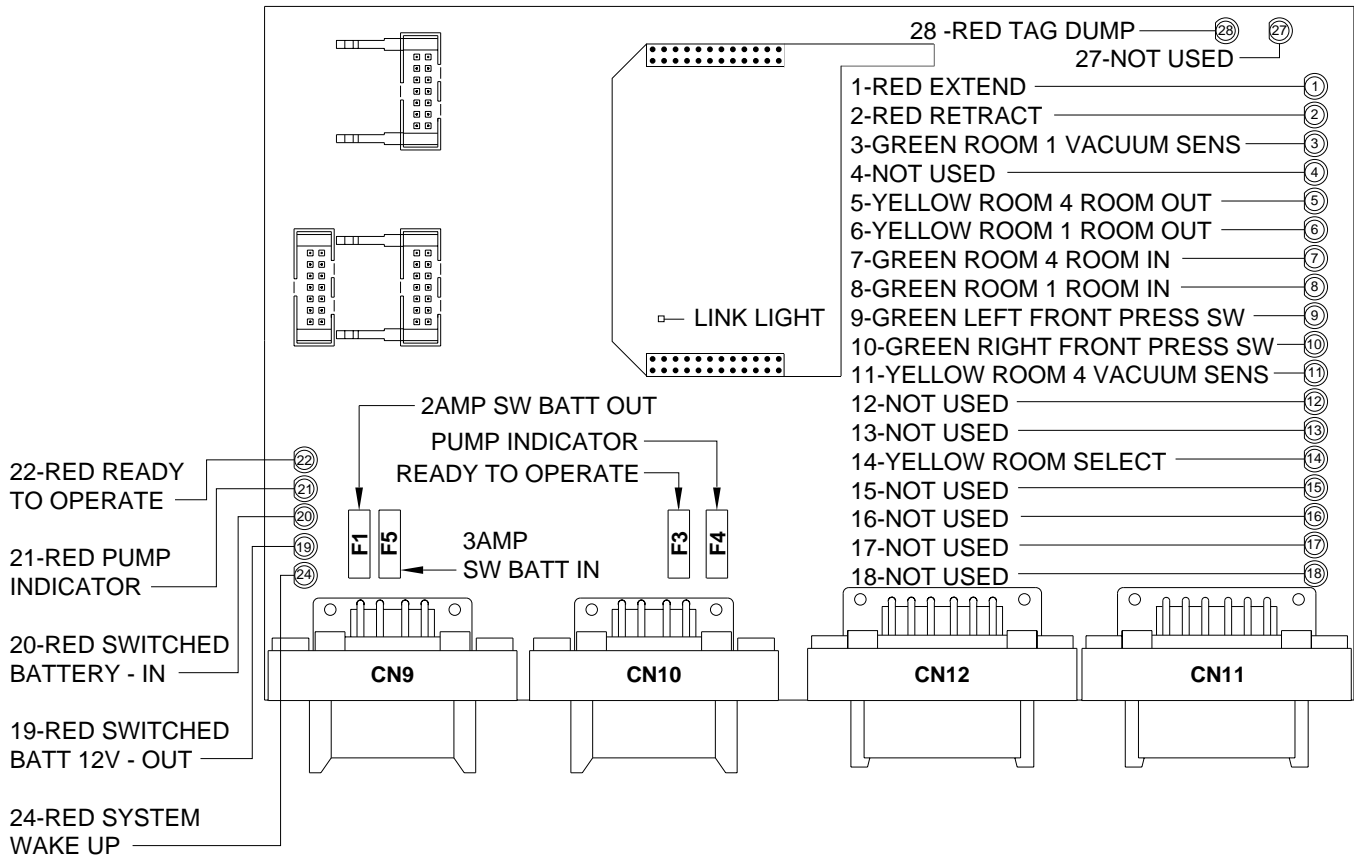

LED	DESCRIPTION	CN AND PIN
1-RED	EXTEND	CN 10 - PIN 4
2-RED	RETRACT	CN 10 - PIN 5
3-RED	ROOM 1 VACUUM SENSOR	CN 12 - PIN 8
4-RED	NOT USED	NOT USED
5-YELLOW	ROOM 4 ROOM OUT	CN 11 - PIN 2
6-YELLOW	ROOM 1 ROOM OUT	CN 12 - PIN 2
7-GREEN	ROOM 4 ROOM IN	CN 11 - PIN 3
8-GREEN	ROOM 1 ROOM IN	CN 12 - PIN 3
9-GREEN	LEFT FRONT PRESSURE SW	CN 11 - PIN 10
10-GREEN	RIGHT FRONT PRESSURE SW	CN 12 - PIN 10
11-YELLOW	ROOM 4 VACUUM SENSOR	CN 11 - PIN 1
12 AND 13 - YELLOW	NOT USED	NOT USED
14-YELLOW	ROOM SELECT	CN 10 - PIN 1
15 THRU 18 - GREEN	NOT USED	NOT USED
19-RED	12V OUTPUT	CN 11/CN12 PIN 7
20-RED	SWITCHED BATTERY	CN 9 - PIN 3
21-RED	PUMP INDICATOR	CN 10 - PIN 3
22-RED	READY TO OPERATE	CN 10 - PIN 2
24-RED	SYSTEM WAKE UP	CN 10 - PIN 7
27 - RED	NOT USED	NOT USED
28-RED	TAG DUMP	CN 12 - PIN 11

FUSE DESCRIPTION
F1 - 2AMP SW BATTERY OUT
F3 - 2AMP READY TO OPERATE
F4 - 2AMP PUMP INDICATOR
F5 - 3AMP SWITCHED BATTERY IN

NOTE: FOR DETAILED INPUT / OUTPUT INFORMATION ABOUT PIN CONNECTIONS SEE ELECTRICAL CONNECTION DIAGRAM - FRONT AIR MODULE PAGE 3 OF 6.

ELECTRICAL CONNECTION DIAGRAM

REAR AIR - ROOMS 2 AND 3 MODULE

PAGE 1 OF 6

NOTE: FOR AIR MANIFOLD PIGTAIL PIN AND WIRE INFORMATION - SEE AIR MANIFOLD PIGTAIL - DRIVE AXLE PAGE

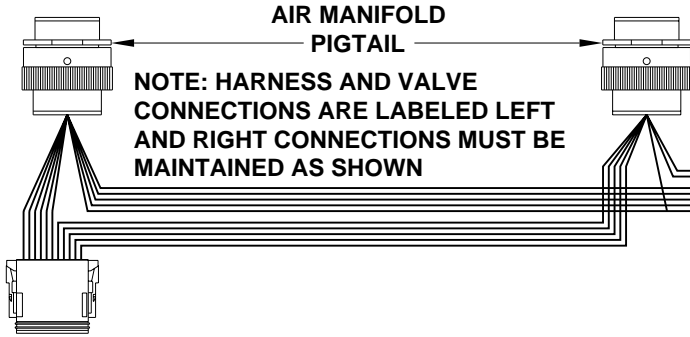

AIR MANIFOLD PIGTAIL

NOTE: HARNESS AND VALVE CONNECTIONS ARE LABELED LEFT AND RIGHT CONNECTIONS MUST BE MAINTAINED AS SHOWN

NOTE: FOR AIR MANIFOLD PIGTAIL PIN AND WIRE INFORMATION - SEE AIR MANIFOLD PIGTAIL - TAG AXLE

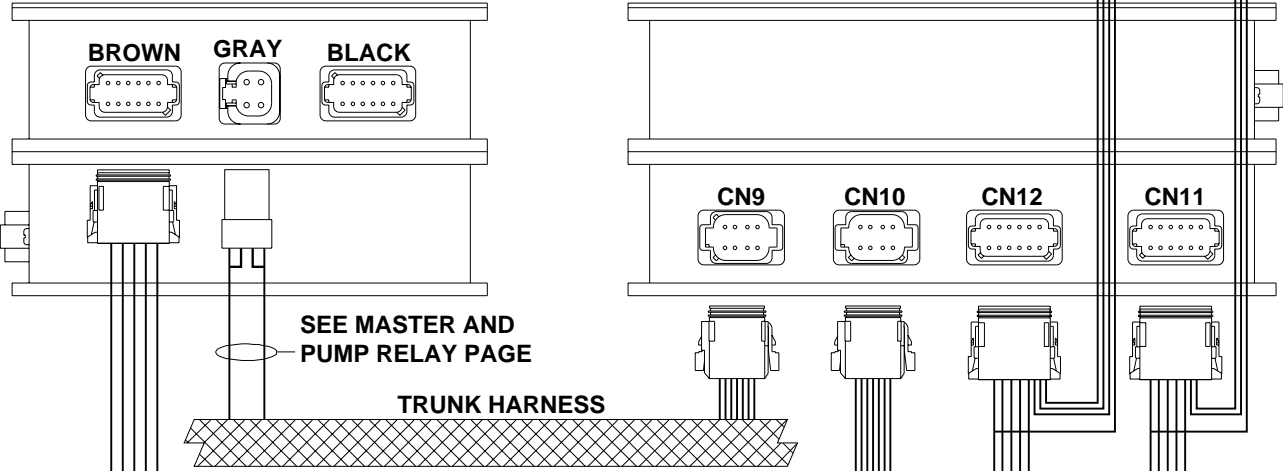

SEE MASTER AND PUMP RELAY PAGE

TRUNK HARNESS

ROOM SELECTOR SWITCH BY O.E.M.

SEE ROOM EXTENSION PANEL PAGE

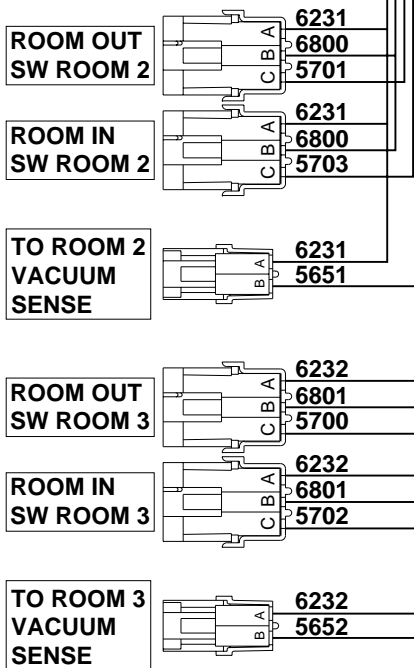
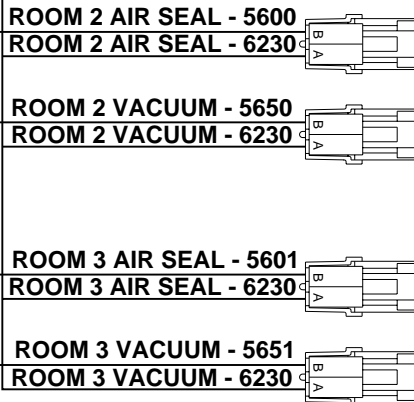

NOTE: FOR MODULE CONNECTION PIN AND WIRE INFORMATION - SEE REAR AIR - ROOM 2 AND 3 MODULE PAGES 2 AND 3 OF 6.

ELECTRICAL CONNECTION DIAGRAM

REAR AIR - ROOMS 2 AND 3 MODULE

PAGE 2 OF 6

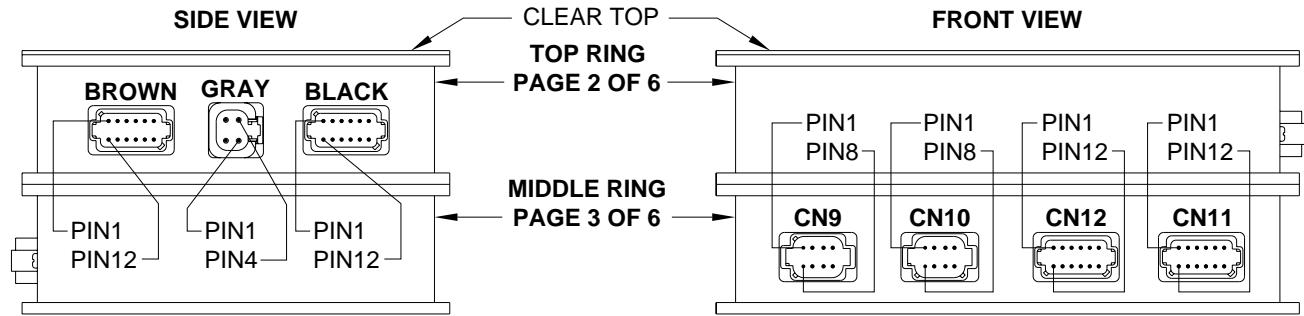

PIN #	WIRE COLOR	WIRE NUMBER	WIRE DESCRIPTION AND FUNCTION
TOP RING			
BROWN			
			12 PIN BROWN CONNECTOR
1	BLACK	5650	ROOM 2 AIR SEAL MANIFOLD VACUUM - SWITCHED +12
2	BLACK	5600	ROOM 2 AIR SEAL MANIFOLD - SWITCHED +12
3	BLACK	5651	ROOM 3 AIR SEAL MANIFOLD VACUUM - SWITCHED +12
4	BLACK	5601	ROOM 3 AIR SEAL MANIFOLD - SWITCHED +12
5 THRU 10			NO CONNECTION
11	WHITE	6230	GROUND
12			NO CONNECTION
GRAY			
			4 PIN GRAY CONNECTOR
1	RED	6800	SWITCHED +12 FROM MASTER RELAY
2	RED	6800	SWITCHED +12 FROM MASTER RELAY
3	GREEN	6230	GROUND FROM GROUND STUD - FOR SOLENOID VALVES
4	GREEN	6230	GROUND FROM GROUND STUD - FOR SOLENOID VALVES
BLACK			
			12 PIN BLACK CONNECTOR
1	BLACK	3800	TAG LIFT SWITCHED +12 FROM TAG DUMP SWITCH
2	BLACK	4500	LEFT REAR RAISE SWITCHED +12
3	BLACK	4600	LEFT REAR LOWER SWITCHED +12
4	BLACK	3500	RIGHT REAR RAISE SWITCHED +12
5	BLACK	3600	RIGHT REAR LOWER SWITCHED +12
6			NO CONNECTION
7	BLACK	3701	TAG ENABLE SWITCHED +12
8	BLACK	3700	REAR TRAVEL SWITCHED +12
9	BLACK	3601	RIGHT SIDE TAG DUMP SWITCHED +12
10	WHITE	4601	LEFT SIDE TAG DUMP SWITCHED +12
11	WHITE	6258	GROUND FOR SOLENOID VALVES
12			NO CONNECTION

ELECTRICAL CONNECTION DIAGRAM

REAR AIR - ROOMS 2 AND 3 MODULE

PAGE 3 OF 6

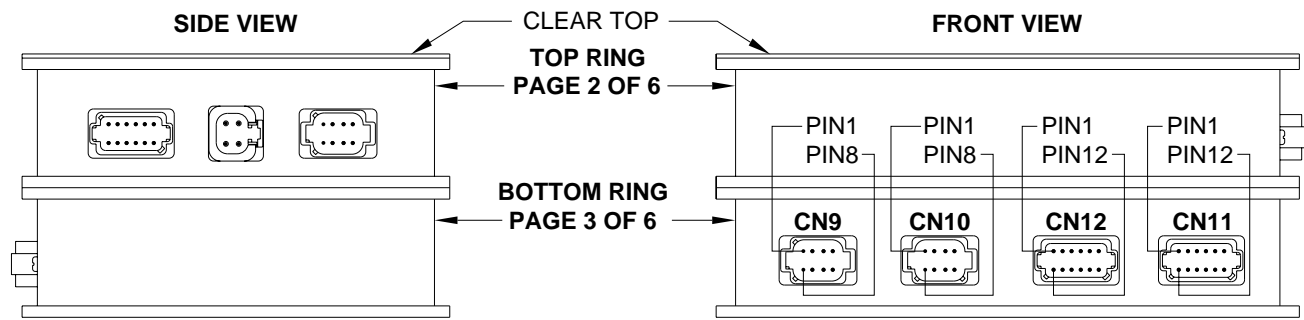

PIN #	WIRE COLOR	WIRE NUMBER	WIRE DESCRIPTION AND FUNCTION
CN9			8 PIN BLACK CONNECTOR
1	WHITE	7696	SYSTEM WAKE UP SWITCHED GROUND
2	RED	6121	SWITCHED +12 FROM IGNITION
3	RED	6800	SWITCHED +12 BATTERY
4	GREEN	6230	GROUND TO TOUCH PANEL
5			SHIELD WIRE FOR CAN CABLE
6	RED	6110	SWITCHED +12 FROM IGNITION
7	GREEN	-	CAN DATA LINE LOW-DO NOT MODIFY
8	YELLOW	-	CAN DATA LINE HIGH-DO NOT MODIFY
CN10			8 PIN GRAY CONNECTOR
1	BLACK	6806	ROOM SELECT SWITCH - SWITCHED +12 FOR ROOM 3
2	WHITE	7510	READY TO OPERATE LIGHT CONTROL SW +12
3	WHITE	7530	PUMP ON LIGHT CONTROL - SWITCHED +12
4	WHITE	7501	ROOM 2 EXTEND SWITCHED +12
5	WHITE	7502	ROOM 2 RETRACT SWITCHED +12
6	RED	6805	SWITCHED +12 BATT TO ROOM PANEL KEY SWITCH
7	WHITE	7696	SYSTEM WAKE UP - SWITCHED GROUND
8	GREEN	6230	GROUND TO ROOM PANEL KEY SWITCH
CN12			12 PIN GRAY CONNECTOR
1	BLACK	4211	LEFT SIDE TAG PRESSURE SWITCH - SWITCHED GROUND
2	BLACK	5701	ROOM OUT LIMIT SWITCH - ROOM 2 - SWITCHED GROUND
3	BLACK	5703	ROOM IN LIMIT SWITCH - ROOM 2 - SWITCHED GROUND
4	BLACK	3211	RIGHT SIDE TAG PRESSURE SWITCH - SWITCHED GROUND
5			NO CONNECTION
6	WHITE	6231	GROUND
7	BLACK	6800	SWITCHED +12 BATTERY
8	BLACK	5651	VACUUM SENSOR - ROOM 2 - SWITCHED GROUND
9	BLACK	3215	SYSTEM PRESSURE SWITCH - SWITCHED GROUND
10 THRU 12			NO CONNECTION
CN11			12 PIN GREEN CONNECTOR
1	BLACK	5652	VACUUM SENSOR - ROOM 3 - SWITCHED GROUND
2	BLACK	5700	ROOM OUT LIMIT SWITCH - ROOM 3 SWITCHED GROUND
3	BLACK	5702	ROOM IN LIMIT SWITCH - ROOM 3 SWITCHED GROUND
4	BLACK	3210	RIGHT REAR DRIVE AXLE PRESS SW - SWITCHED GROUND
5			NO CONNECTION
6	WHITE	6232	GROUND
7	BLACK	6801	SWITCHED +12 BATTERY
8	BLACK	4210	LEFT REAR DRIVE AXLE PRESS SW - SWITCHED GROUND
9 THRU 12			NO CONNECTION

ELECTRICAL CONNECTION DIAGRAM
LED - FUSE LOCATION AND DESCRIPTION
REAR AIR - ROOMS 2 AND 3 MODULE (TOP RING)
PAGE 4 OF 6

REAR AND TAG AIR LEVEL OUTPUT BOARD

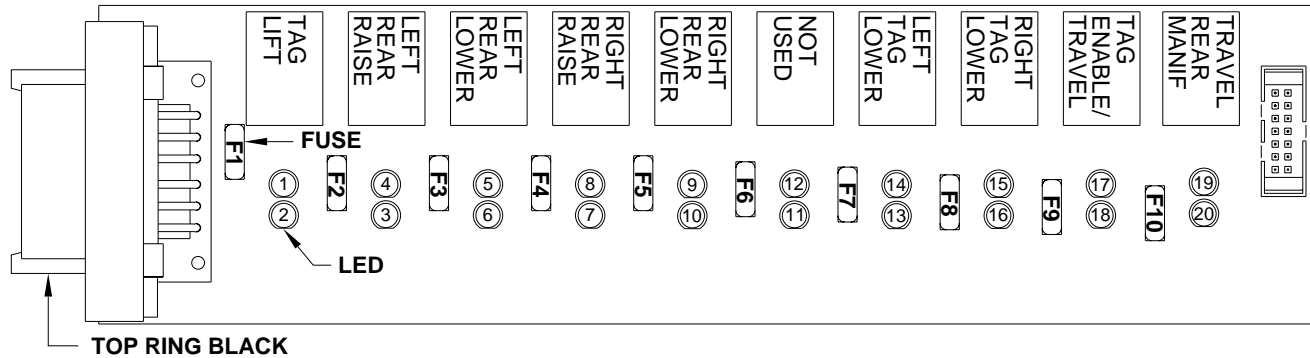

LED	RELAY DESCRIPTION	FUSE	BLACK
1-YELLOW	TAG LIFT		
2-RED	TAG LIFT	F1 - 5 AMP	PIN 1
3-RED	LEFT REAR RAISE	F2 - 5 AMP	PIN 2
4-YELLOW	LEFT REAR RAISE		
5-YELLOW	LEFT REAR LOWER		
6-RED	LEFT REAR LOWER	F3-5 AMP	PIN 3
7-RED	RIGHT REAR RAISE	F4-5 AMP	PIN 4
8-YELLOW	RIGHT REAR RAISE		
9-YELLOW	RIGHT REAR LOWER		
10-RED	RIGHT REAR LOWER	F5 - 5 AMP	PIN 5
11-RED	NOT USED	F6 - 5 AMP	PIN 6
12-YELLOW	NOT USED		
13-RED	LEFT TAG LOWER	F7 - 5 AMP	PIN 10
14-YELLOW	LEFT TAG LOWER		
15-YELLOW	RIGHT TAG LOWER		
16-RED	RIGHT TAG LOWER	F8 - 5 AMP	PIN 9
17-YELLOW	TAG ENABLE/TRAVEL		
18-RED	TAG ENABLE/TRAVEL	F9 - 3 AMP	PIN 7
19-YELLOW	TRAVEL - REAR MANIFOLD		
20-RED	TRAVEL - REAR MANIFOLD	F10-3 AMP	PIN 8

NOTE: FOR DETAILED INPUT / OUTPUT INFORMATION ABOUT PIN CONNECTIONS SEE ELECTRICAL CONNECTION DIAGRAM - REAR AIR - ROOM 2 MODULE PAGE 2 OF 6.

NOTE: A LIT YELLOW LED INDICATES THERE IS A GROUND SIGNAL TO TURN THE CORRESPONDING RELAY ON.

A LIT RED LED INDICATES THERE IS VOLTAGE ON IT'S CORRESPONDING CN1 PIN.

IF A YELLOW LED IS LIT AND THE CORRESPONDING RED LED IS OFF, EITHER IT'S FUSE IS BLOWN OR THE RELAY IS BAD.

IF THE YELLOW LEDS ARE WORKING BUT NO RED LED IS COMING ON THERE IS A PROBLEM WITH INPUT VOLTAGE IN THE 4-PIN CONNECTOR ON THE TOP RING.

IF A YELLOW LED IS NOT LIT, THIS INDICATES A PROBLEM WITH A MODULE.

NOTE: THE TRAVEL RELAY IS WIRED AS A NORMALLY CLOSED RELAY. WHEN THE YELLOW LED (19) IS ON THE RELAY CONTACTS WILL OPEN. THE RED LED (20) WILL NOT BE ON. THE RED LED WILL BE ON IF THE LEVELING SYSTEM IS IN THE TRAVEL MODE AND THE IGNITION IS ON.

ELECTRICAL CONNECTION DIAGRAM
LED - FUSE LOCATION AND DESCRIPTION
REAR AIR - ROOMS 2 AND 3 MODULE (TOP RING)
PAGE 5 OF 6

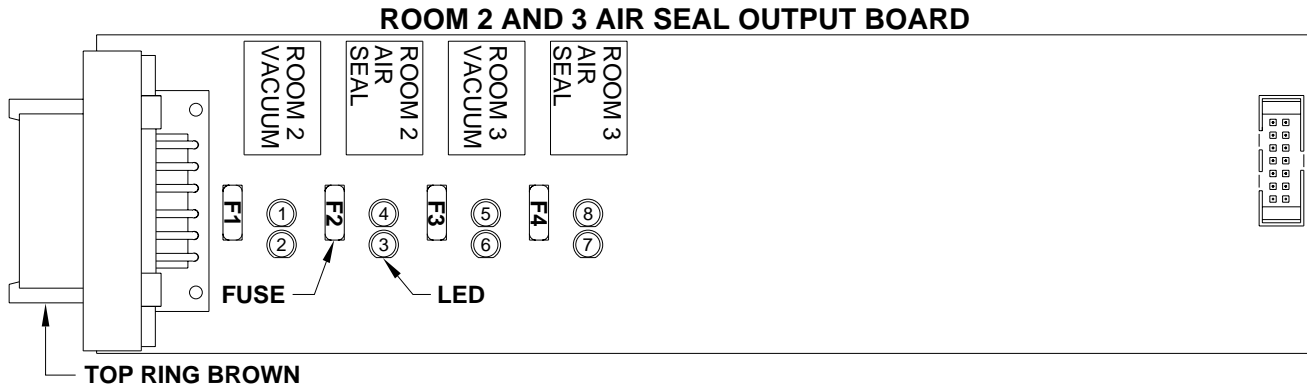

LED	RELAY DESCRIPTION	FUSE	BROWN
YELLOW-COIL RED- CONTACTS			
1-YELLOW	ROOM 2 VACUUM		
2-RED	ROOM 2 VACUUM	F1 - 5 AMP	PIN 1
3-RED	ROOM 2 AIR SEAL	F2 - 5 AMP	PIN 2
4-YELLOW	ROOM 2 AIR SEAL		
5-YELLOW	ROOM 3 VACUUM		
6-RED	ROOM 3 VACUUM	F3 - 5 AMP	PIN 3
7-RED	ROOM 3 AIR SEAL	F4 - 5 AMP	PIN 4
8-YELLOW	ROOM 3 AIR SEAL		

NOTE: FOR DETAILED INPUT / OUTPUT INFORMATION ABOUT PIN CONNECTIONS SEE ELECTRICAL CONNECTION DIAGRAM - FRONT AIR MODULE PAGE 2 OF 6.

NOTE: A LIT YELLOW LED INDICATES THERE IS A GROUND SIGNAL TO TURN THE CORRESPONDING RELAY ON.

A LIT RED LED INDICATES THERE IS VOLTAGE ON IT'S CORRESPONDING PIN.

IF A YELLOW LED IS LIT AND THE CORRESPONDING RED LED IS OFF, EITHER IT'S FUSE IS BLOWN OR THE RELAY IS BAD.

IF THE YELLOW LEDS ARE WORKING BUT NO RED LED IS COMING ON THERE IS A PROBLEM WITH INPUT VOLTAGE IN THE 4-PIN CONNECTOR ON THE TOP RING.

IF A YELLOW LED IS NOT LIT, THIS INDICATES A PROBLEM WITH A MODULE.

ELECTRICAL CONNECTION DIAGRAM

LED - FUSE LOCATION AND DESCRIPTION

REAR AIR - ROOMS 2 AND 3 MODULE

PAGE 6 OF 6

REAR AIR - ROOMS 2 AND 3 I/O BOARD

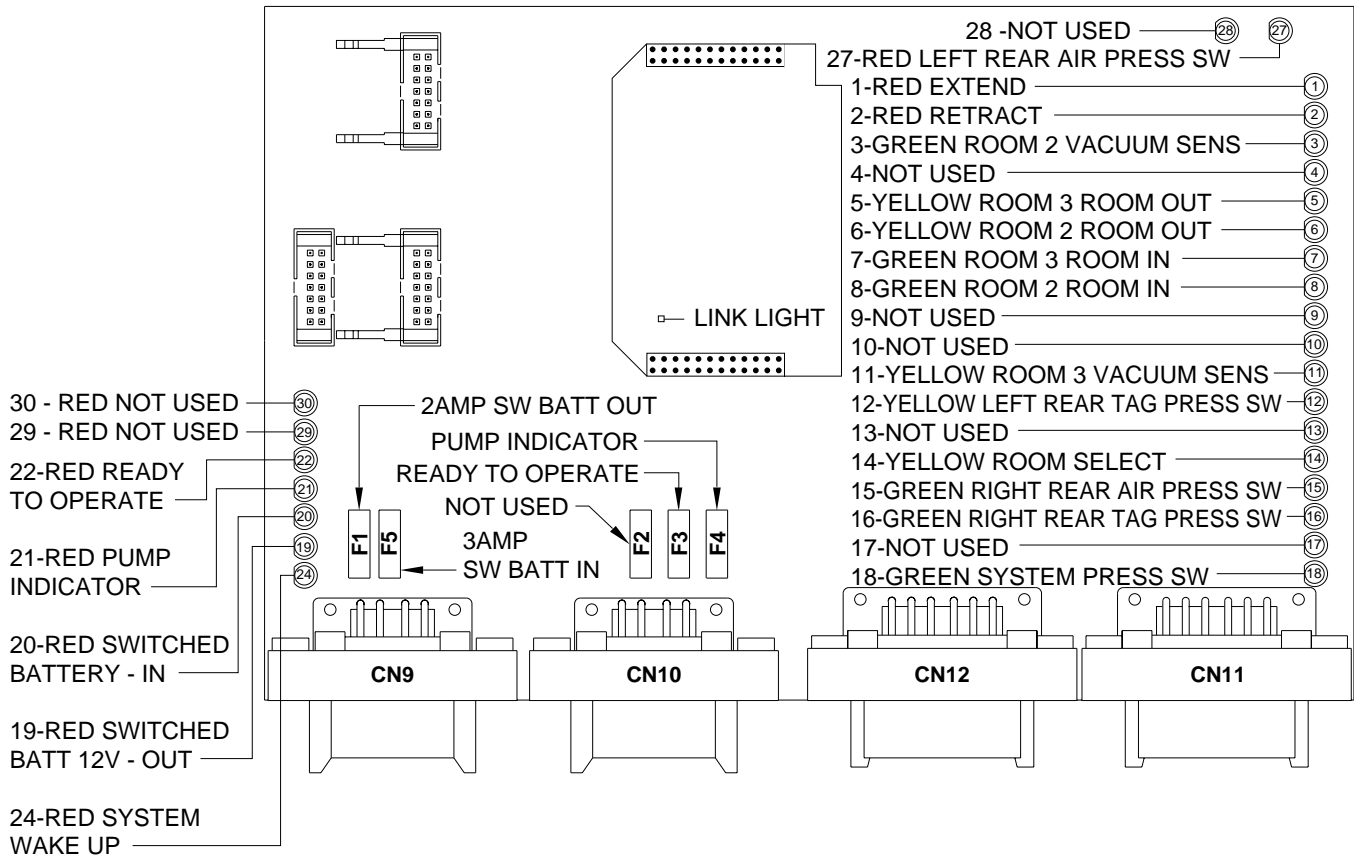

LED	DESCRIPTION	CN AND PIN
1-RED	EXTEND	CN 10 - PIN 4
2-RED	RETRACT	CN 10 - PIN 5
3-GREEN	ROOM 2 VACUUM SENSOR	CN 12 - PIN 8
4-YELLOW	NOT USED	NOT USED
5-YELLOW	ROOM 3 ROOM OUT	CN 11 - PIN 2
6-YELLOW	ROOM 2 ROOM OUT	CN 12 - PIN 2
7-GREEN	ROOM 3 ROOM IN	CN 11 - PIN 3
8-GREEN	ROOM 2 ROOM IN	CN 12 - PIN 3
9-GREEN	NOT USED	NOT USED
10-GREEN	NOT USED	NOT USED
11-YELLOW	ROOM 3 VACUUM SENSOR	CN 11 - PIN 1
12-YELLOW	LEFT REAR TAG PRESS SW	CN 12 - PIN 1
13-YELLOW	NOT USED	NOT USED
14-YELLOW	ROOM SELECT	CN 10 - PIN 1
15-GREEN	RIGHT REAR AIR PRESS SW	CN 11 - PIN 4
16-GREEN	RIGHT REAR TAG PRESS SW	CN 12 - PIN 4
17-GREEN	NOT USED	NOT USED
18-GREEN	SYSTEM PRESSURE SWITCH	CN 12 - PIN 9
19-RED	12V OUTPUT	CN 11/CN12 PIN 7
20-RED	SWITCHED BATTERY	CN 9 - PIN 3
21-RED	PUMP INDICATOR	CN 10 - PIN 3
22-RED	READY TO OPERATE	CN 10 - PIN 2
23-RED	NOT USED	NOT USED
24-RED	SYSTEM WAKE UP	CN 10 - PIN 7
27 - RED	LEFT REAR AIR PRESS SW	CN 11 - PIN 8
28-RED	NOT USED	NOT USED
29-RED	NOT USED	NOT USED
30-RED	NOT USED	NOT USED

FUSE DESCRIPTION
F1 - 2AMP SW BATTERY OUT
F2 - 2AMP NOT USED
F3 - 2AMP READY TO OPERATE
F4 - 2AMP PUMP INDICATOR
F5 - 3AMP SWITCHED BATTERY IN

NOTE: FOR DETAILED INPUT / OUTPUT INFORMATION ABOUT PIN CONNECTIONS SEE ELECTRICAL CONNECTION DIAGRAM - REAR AIR ROOMS 2 AND 3 PAGE 3 OF 6.

ELECTRICAL CONNECTION DIAGRAM

AIR MANIFOLD PIGTAIL CONNECTION INFORMATION

FRONT AXLE MANIFOLD

PIN	COLOR	DESCRIPTION
1	BLACK	TRAVEL
2	WHITE	GROUND
3	BLACK	RIGHT SIDE PRESS SW
4	WHITE	GROUND
5	BLACK	RIGHT SIDE RAISE
6	WHITE	GROUND
7	BLACK	RIGHT SIDE LOWER
8	WHITE	GROUND
9	BLACK	LEFT SIDE RAISE
10	WHITE	GROUND
11	BLACK	LEFT SIDE LOWER
12	WHITE	GROUND
13	BLACK	TRAVEL
14	WHITE	GROUND
15	BLACK	LEFT SIDE PRESS SW
16	WHITE	GROUND
17	BLACK	SYSTEM PRESS SW
18	WHITE	GROUND
19 THROUGH 31		NOT USED

NOTE: HARNESS AND VALVE CONNECTIONS ARE LABELED LEFT AND RIGHT. CONNECTIONS MUST BE MAINTAINED AS SHOWN.

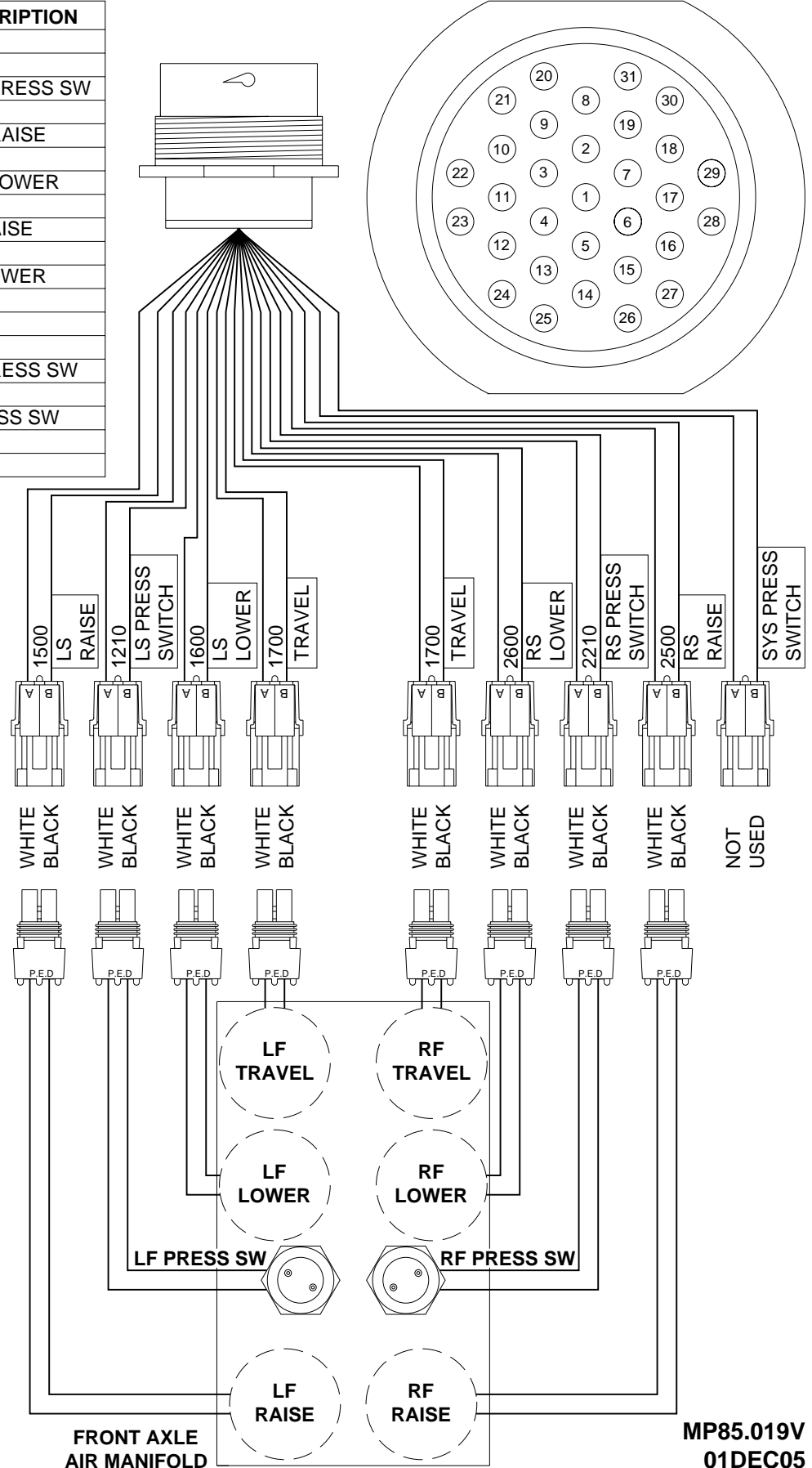

**MP85.019V
01DEC05**

ELECTRICAL CONNECTION DIAGRAM

AIR MANIFOLD PIGTAIL CONNECTION INFORMATION

DRIVE AXLE MANIFOLD

PIN	COLOR	DESCRIPTION
1	BLACK	TRAVEL
2	WHITE	GROUND
3	BLACK	RIGHT SIDE PRESS SW
4	WHITE	GROUND
5	BLACK	RIGHT SIDE RAISE
6	WHITE	GROUND
7	BLACK	RIGHT SIDE LOWER
8	WHITE	GROUND
9	BLACK	LEFT SIDE RAISE
10	WHITE	GROUND
11	BLACK	LEFT SIDE LOWER
12	WHITE	GROUND
13	BLACK	TRAVEL
14	WHITE	GROUND
15	BLACK	LEFT SIDE PRESS SW
16	WHITE	GROUND
17	BLACK	SYSTEM PRESS SW
18	WHITE	GROUND
19 THROUGH 31		NOT USED

NOTE: HARNESS AND VALVE CONNECTIONS ARE LABELED LEFT AND RIGHT. CONNECTIONS MUST BE MAINTAINED AS SHOWN.

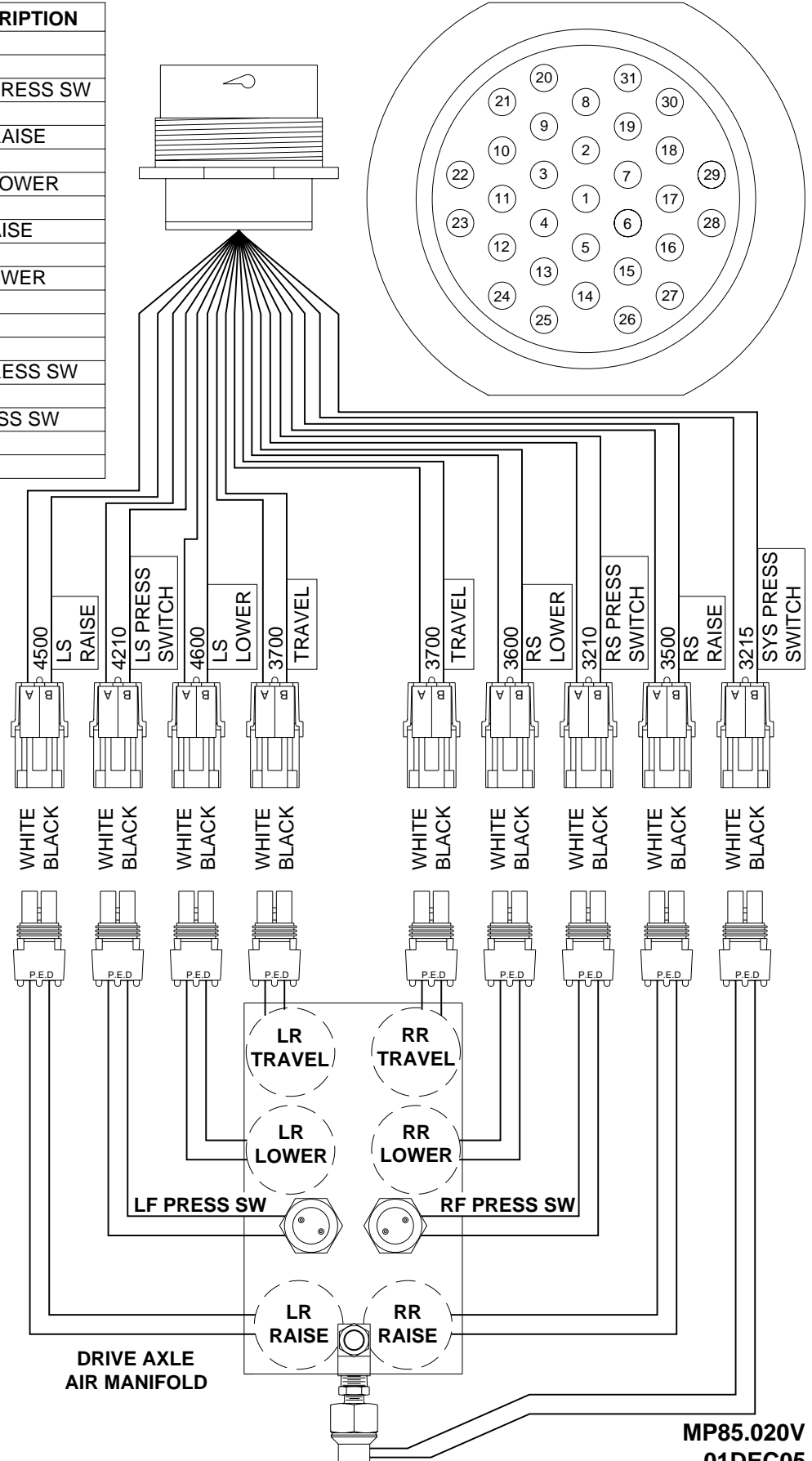

ELECTRICAL CONNECTION DIAGRAM

AIR MANIFOLD PIGTAIL CONNECTION INFORMATION

TAG AXLE MANIFOLD

PIN	COLOR	DESCRIPTION
1	BLACK	RIGHT SIDE ENABLE
2	WHITE	GROUND
3	BLACK	RIGHT SIDE PRESS SW
4	WHITE	GROUND
5	BLACK	TAG LIFT
6	WHITE	GROUND
7	BLACK	RIGHT SIDE DUMP
8	WHITE	GROUND
9	BLACK	TAG LIFT EXHAUST
10	WHITE	GROUND
11	BLACK	LEFT SIDE DUMP
12	WHITE	GROUND
13	BLACK	LEFT SIDE ENABLE
14	WHITE	GROUND
15	BLACK	LEFT SIDE PRESS SW
16	WHITE	GROUND
17 THROUGH 31		NOT USED

NOTE: HARNESS AND VALVE CONNECTIONS ARE LABELED LEFT AND RIGHT. CONNECTIONS MUST BE MAINTAINED AS SHOWN.

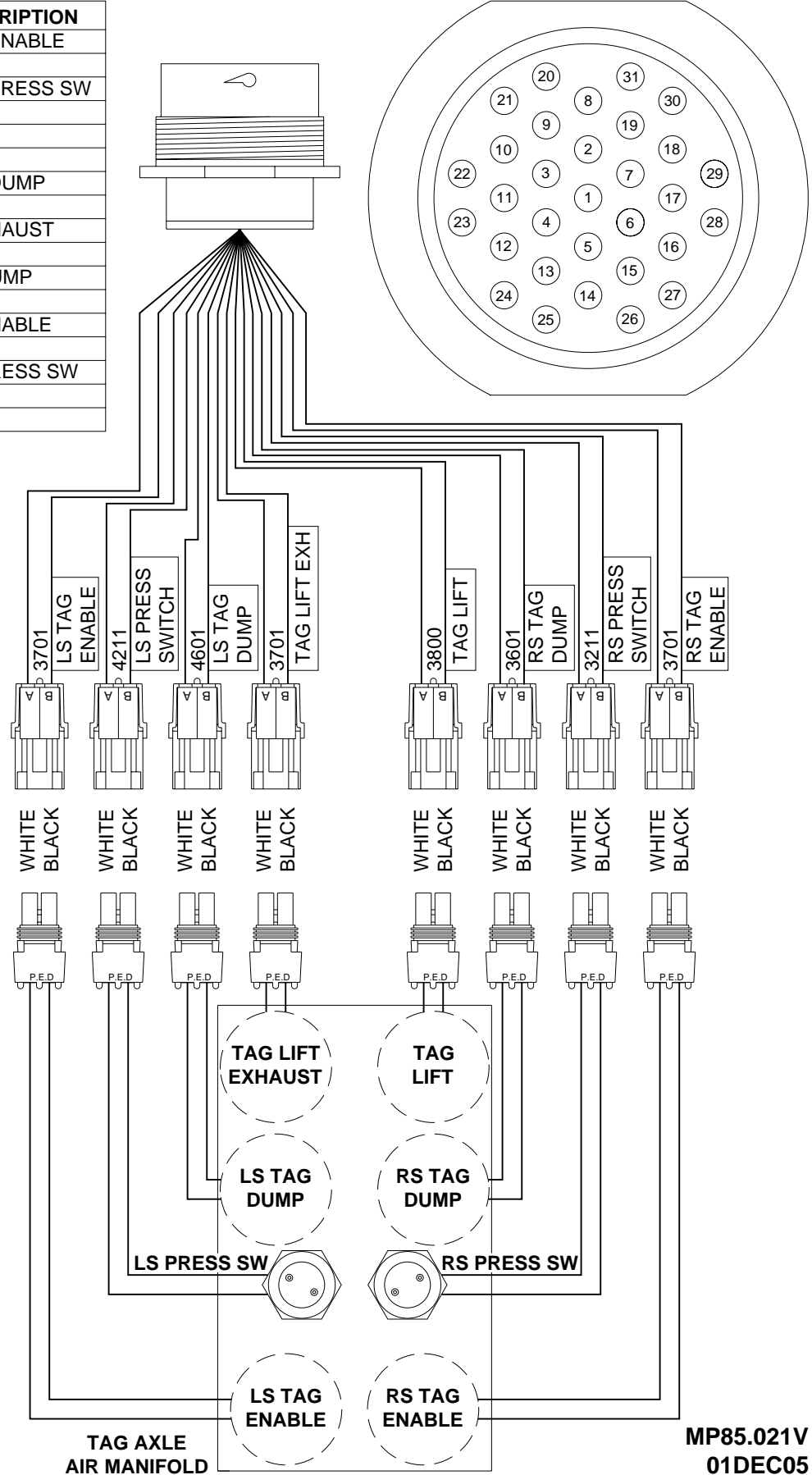

ELECTRICAL CONNECTION DIAGRAM HYDRAULIC MANIFOLD CONNECTIONS ROOM 1 - ROOM 2 - ROOM 3 - ROOM 4 - GEN SLIDE

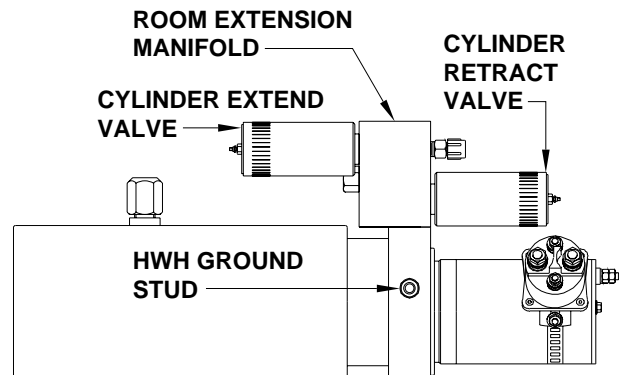
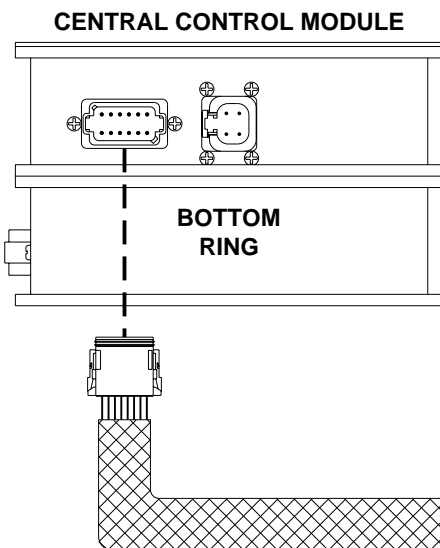
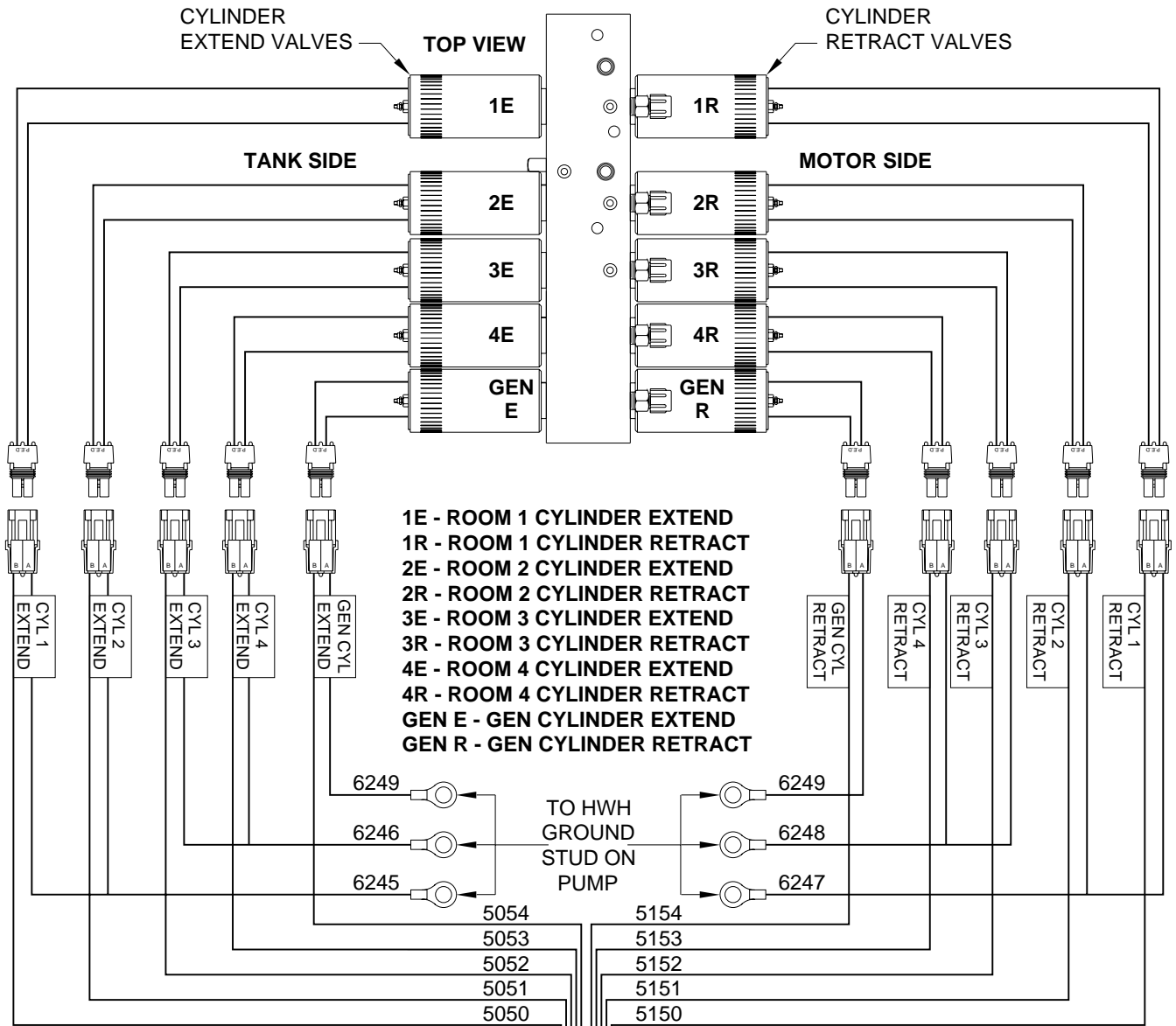

ELECTRICAL CONNECTION DIAGRAM

2000 SERIES ROOM EXTENSION SYSTEM

MASTER AND PUMP RELAY

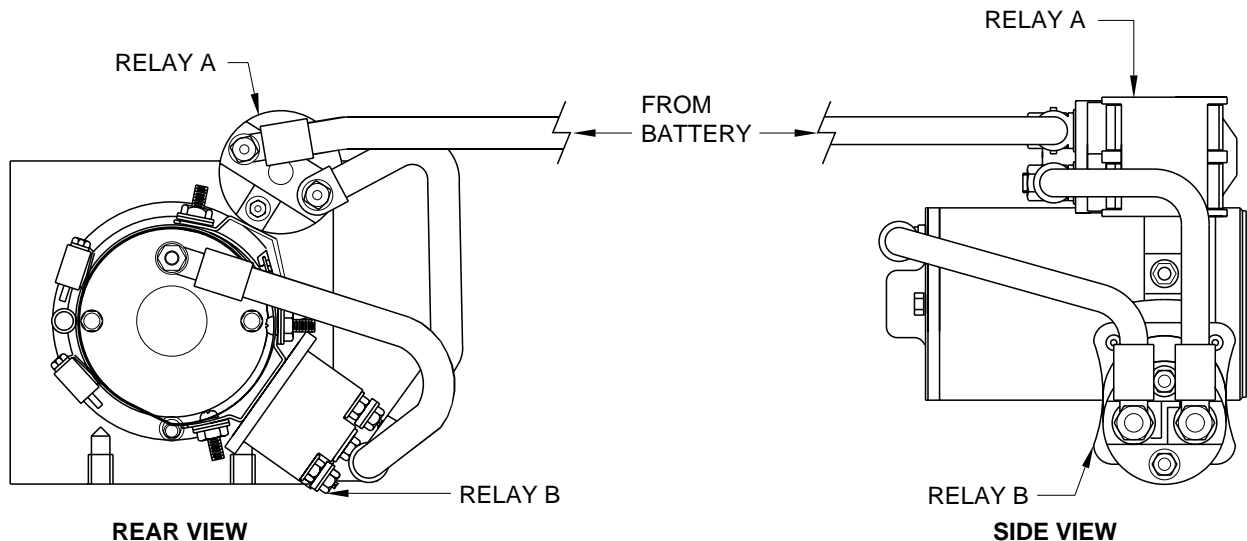
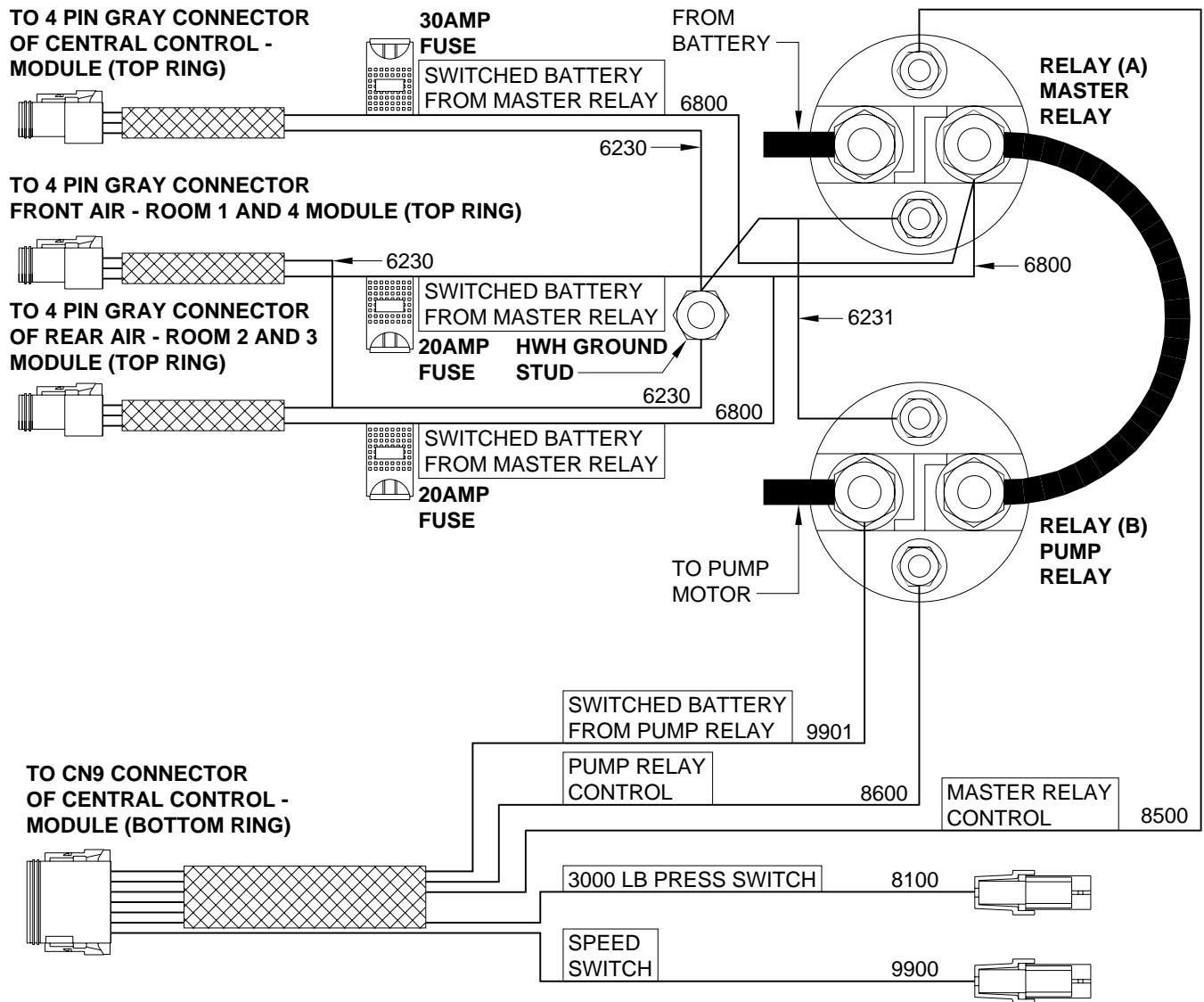

ELECTRICAL CONNECTION DIAGRAM

ROOM EXTENSION PANEL

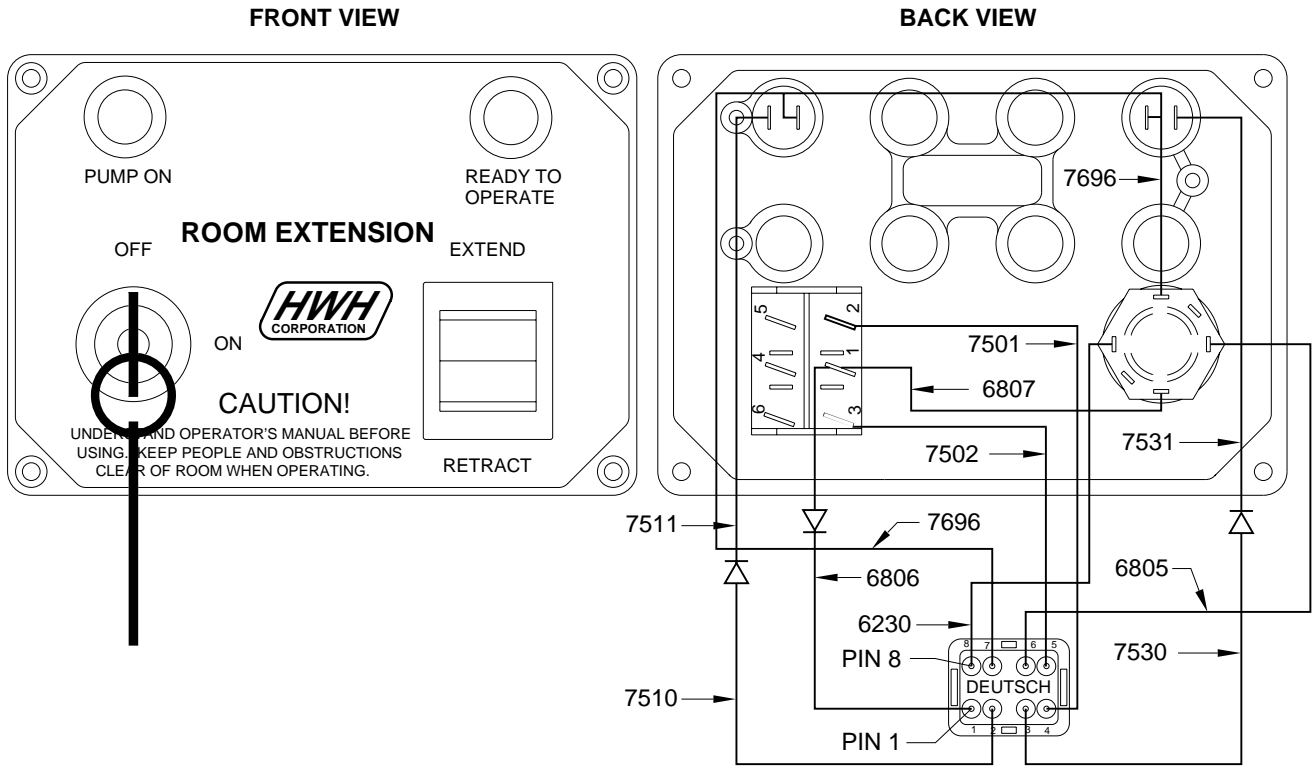

CONNECTOR PIN #	WIRE NUMBER	WIRE DESCRIPTION AND FUNCTION
1	6806/6807	SWITCHED +12 FROM KEY SWITCH FOR ROOM CONTROL SWITCH
2	7510/7511	READY TO OPERATE LIGHT CONTROL WIRE SWITCHED +12V
3	7530/7531	PUMP ON LIGHT CONTROL WIRE SWITCHED +12
4	7501	ROOM EXTEND SWITCHED +12V FROM ROOM CONTROL SWITCH
5	7502	ROOM RETRACT SWITCHED +12V FROM ROOM CONTROL SWITCH
6	6805	SWITCHED +12V TO ROOM PANEL KEY SWITCH
7	7696	SWITCHED GROUND FROM ROOM PANEL KEY SWITCH FOR PANEL INDICATOR LIGHTS AND SYSTEM WAKE UP
8	6230	GROUND SUPPLY FOR ROOM PANEL KEY SWITCH

ELECTRICAL CONNECTION DIAGRAM AUXILIARY COMPRESSOR CONNECTIONS

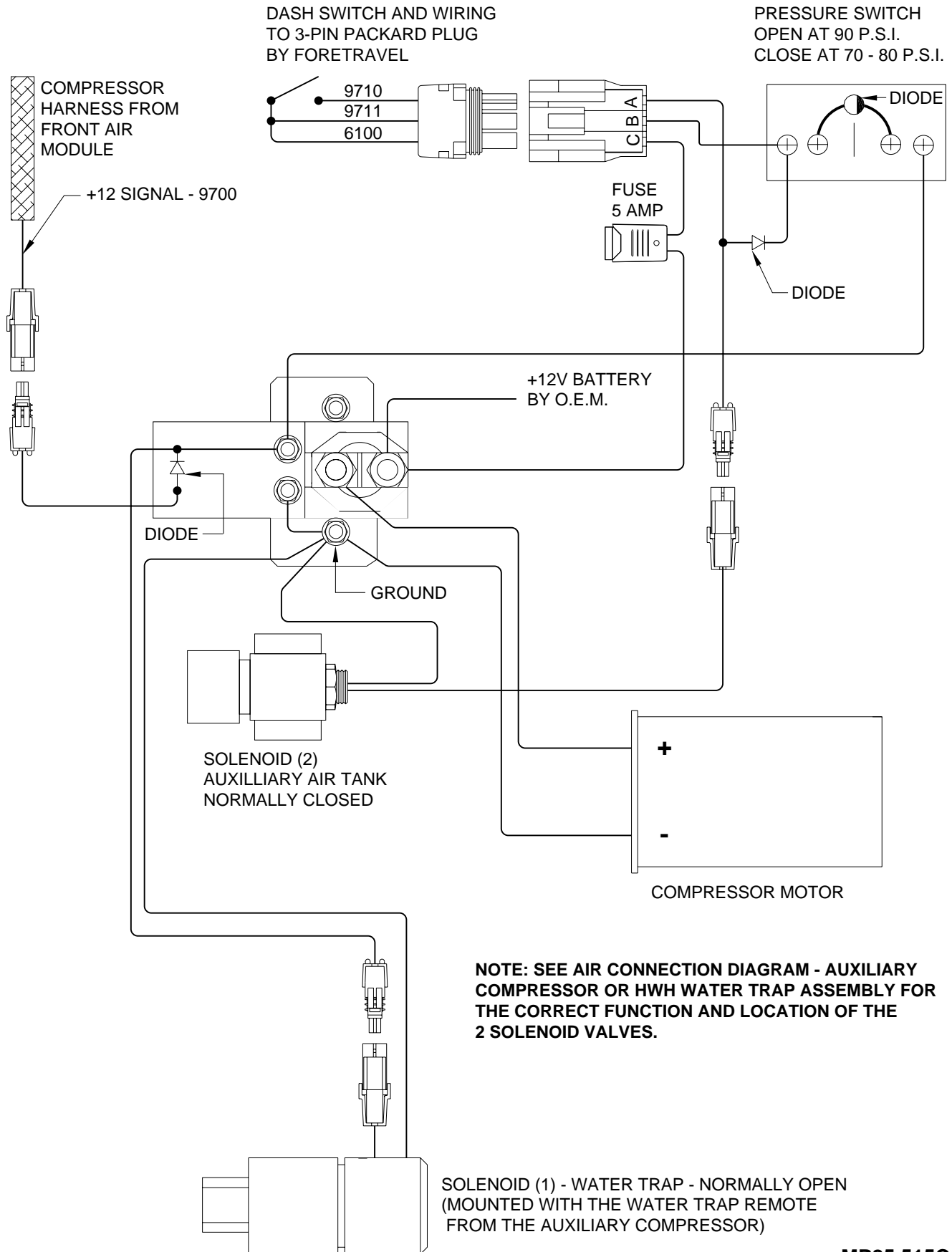

NOTE: SEE AIR CONNECTION DIAGRAM - AUXILIARY COMPRESSOR OR HWH WATER TRAP ASSEMBLY FOR THE CORRECT FUNCTION AND LOCATION OF THE 2 SOLENOID VALVES.

BREATHER CAP - DIPSTICK - 1/4" NUT DRIVER

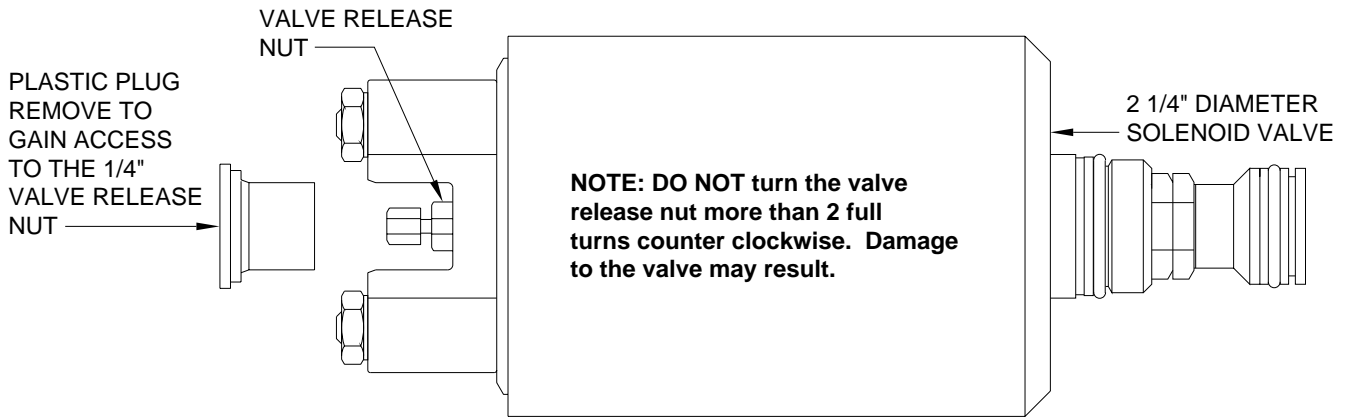
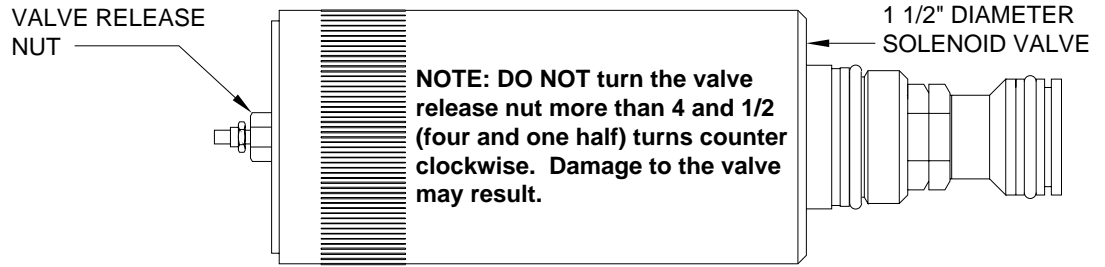

NOTE: THE BREATHER CAP IS LOCATED ON THE TOP SIDE OF THE POWER UNIT RESERVOIR.

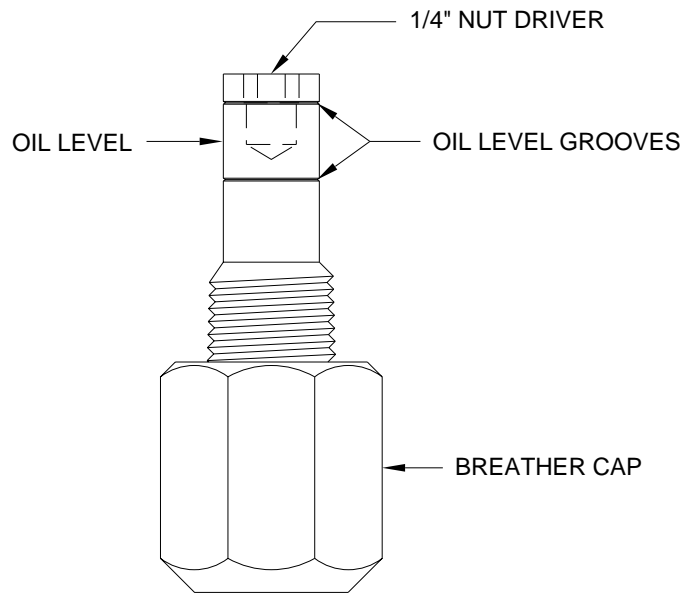

IMPORTANT: PRIOR TO REMOVING THE BREATHER CAP, EITHER TO CHECK THE OIL LEVEL OR TO USE THE 1/4" NUT DRIVER, CLEAN ANY DEBRIS FROM THE TOP OF THE RESERVOIR. BEFORE RETURNING THE BREATHER CAP TO THE RESERVOIR, REMOVE ANY PAINT CHIPS OR OTHER DEBRIS FROM THE DIPSTICK INCLUDING DEBRIS INSIDE THE 1/4" NUT DRIVER.