



OPERATOR'S MANUAL

HWH® JOYSTICK-CONTROLLED 225 SERIES LEVELING SYSTEM

FEATURING:

Joystick BI-AXIS® Control
Hydraulic Leveling
Straight-Acting Jacks
Optional Air Dump

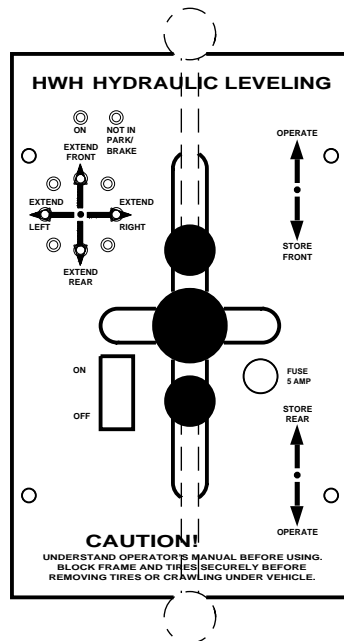

HWH CORPORATION

(On I-80, Exit 267 South)

2096 Moscow Road | Moscow, Iowa 52760

Ph: 800/321-3494 (or) 563/724-3396 | Fax: 563/724-3408

www.hwh.com

OPERATOR'S MANUAL

CAUTION !

READ THE ENTIRE OPERATOR'S MANUAL BEFORE OPERATING.

BLOCK FRAME AND TIRES SECURELY BEFORE CRAWLING UNDER VEHICLE. DO NOT USE LEVELING JACKS OR AIR SUSPENSION TO SUPPORT VEHICLE WHILE UNDER VEHICLE OR CHANGING TIRES. VEHICLE MAY DROP AND/OR MOVE FORWARD OR BACKWARD WITHOUT WARNING CAUSING INJURY OR DEATH.

KEEP ALL PEOPLE CLEAR OF VEHICLE WHILE LEVELING SYSTEM AND ROOM EXTENSION ARE BEING OPERATED.

THE JACKS MAY ABRUPTLY SWING UP WHEN THE FOOT CLEARS THE GROUND OR WHEN JACK REACHES FULL EXTENSION.

NEVER PLACE HANDS OR OTHER PARTS OF THE BODY NEAR HYDRAULIC LEAKS. OIL MAY PENETRATE SKIN CAUSING INJURY OR DEATH.

WEAR SAFETY GLASSES WHEN INSPECTING OR SERVICING THE SYSTEM TO PROTECT EYES FROM DIRT, METAL CHIPS, OIL LEAKS, ETC. FOLLOW ALL OTHER APPLICABLE SHOP SAFETY PRACTICES.

IF THIS VEHICLE IS EQUIPPED WITH KICK-DOWN STYLE JACKS, DO NOT OVER EXTEND THE REAR JACKS. IF THE WEIGHT OF THE VEHICLE IS REMOVED FROM ONE OR BOTH REAR WHEELS, THE VEHICLE MAY ROLL FORWARD OR BACKWARD OFF THE JACKS.

NOTE: KEEP THE CONTROL VALVE LEVERS IN THE STORE POSITION WHEN JACKS ARE NOT IN USE.

IMPORTANT: IF VEHICLE IS EQUIPPED WITH A ROOM EXTENSION, READ ROOM EXTENSION SECTION BEFORE OPERATING LEVELING SYSTEM.

HOW TO OBTAIN WARRANTY SERVICE

THIS IS NOT TO BE INTERPRETED AS A STATEMENT OF WARRANTY

HWH CORPORATION strives to maintain the highest level of customer satisfaction. Therefore, if you discover a defect or problem, please do the following:

FIRST: Notify the dealership where you purchased the vehicle or had the leveling system installed. Dealership management people are in the best position to resolve the problem quickly. If the dealer has difficulty solving the problem, he should immediately contact the Customer Service Department, at HWH CORPORATION.

SECOND: If your dealer cannot or will not solve the problem, notify the Customer Service Department:
HWH CORPORATION 2096 Moscow Rd. Moscow IA. 52760
(563) 724-3396 OR (800) 321-3494. Give your name and address, coach manufacturer and model year, date the coach was purchased, or the date of system installation,

description of the problem, and where you can be reached during business hours (8:00 a.m. till 5:00 p.m. c.s.t.). HWH CORPORATION personnel will contact you to determine whether or not your claim is valid. If it is, HWH CORPORATION will authorize repair or replacement of the defective part, either by appointment at the factory or by the authorization of an independent service facility, to be determined by HWH CORPORATION. All warranty repairs must be performed by an independent service facility authorized by HWH CORPORATION, or at the HWH CORPORATION factory, unless prior written approval has been obtained from proper HWH CORPORATION personnel.

CONTROL IDENTIFICATION

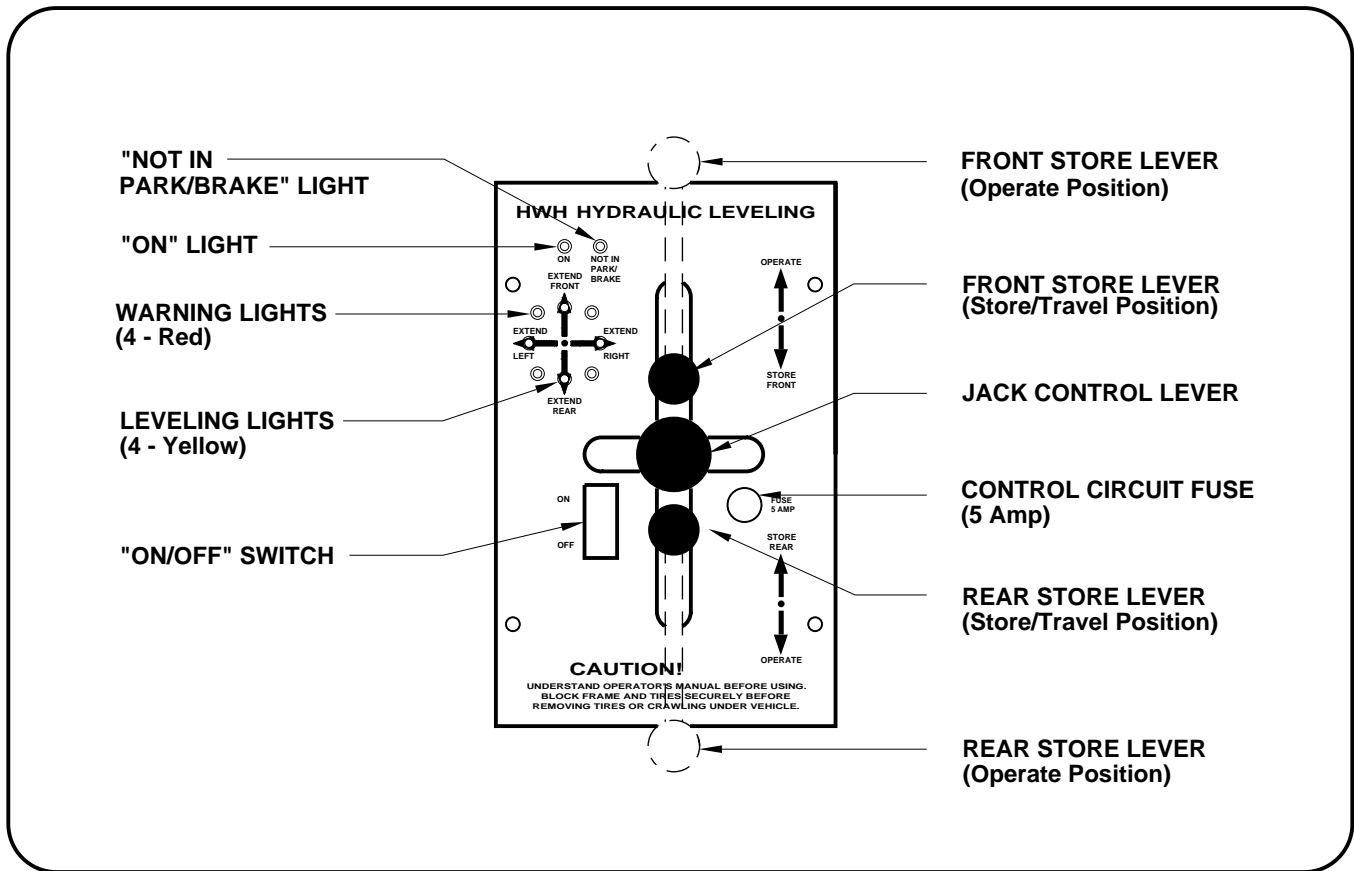

CONTROL FUNCTIONS

CONTROL BUTTONS

"ON/OFF" SWITCH: This is the "ON/OFF" switch for the leveling system. It provides control power to operate the electrical relay on the pump and the LEVELING LIGHTS. It does not control power to the four red WARNING LIGHTS, the master "JACKS DOWN" warning light, or the warning buzzer.

STORE LEVERS: These two levers are used to retract the jacks into the STORE/TRAVEL position. They must be in the position for leveling.

JACK CONTROL LEVER: Jacks are extended in pairs by pushing the jack control lever to one of the EXTEND positions. This movement of the lever activates the pump and directs hydraulic fluid to the jacks. When the lever is released it will return to the neutral (center) position, turning off the pump and stopping jacks in position.

AIR DUMP SWITCH: (Not Shown) This is a remotely mounted, momentary switch. This switch will exhaust the air from the vehicle suspension.

INDICATOR LIGHTS

ON LIGHT: This light indicates the system is on.

"NOT IN PARK/BRAKE" LIGHT: This indicator light is on when the switch is on, but the hand/auto park brake is not set.

LEVELING LIGHTS: If a yellow LEVELING light is on, that indicates a side or end of the vehicle is low. Extend the appropriate jack pairs to put out the yellow light. Only one yellow leveling light should be on at a time. The vehicle is level when all yellow lights are out.

WARNING LIGHTS: A red WARNING light will be on whenever the corresponding jack is extended approximately 1 inch or more provided the ignition switch is in the "ACCESSORY" or "ON" position. Some coaches are equipped with a dash mounted master "JACKS DOWN" light which will be on when one or more jacks are extended, provided the ignition switch is "ON".

WARNING BUZZER: A buzzer will sound if a jack is extended 1 inch or more and the ignition switch is "ON".

OPERATING PROCEDURES

SITE SELECTION

Maintain adequate clearance in all directions for vehicle, room extensions, awnings, doors, steps, etc. Vehicle may move in any direction due to jack extension or retraction, settling of jacks or vehicle, equipment malfunction, etc. If parking on soft ground or asphalt paving, wood blocks or pads should be placed under the jacks.

NOTE: This manual is for vehicles with or without an air suspension. If equipped with an air suspension, the air must be completely exhausted from the suspension before leveling the vehicle.

ROOM EXTENSION PROCEDURES

IMPORTANT: If the vehicle is equipped with a room extension read this section carefully.

If the vehicle is equipped with kick-down jacks, the wheels **MUST** be blocked securely. It is recommended to complete the Leveling Procedure before operating room extensions. It is recommended to retract room extensions before retracting jacks.

Refer to the vehicle owners manual for proper operation of room extensions.

IMPORTANT: Do not use a room extension support when the vehicle is supported by the leveling system.

LEVELING PROCEDURE

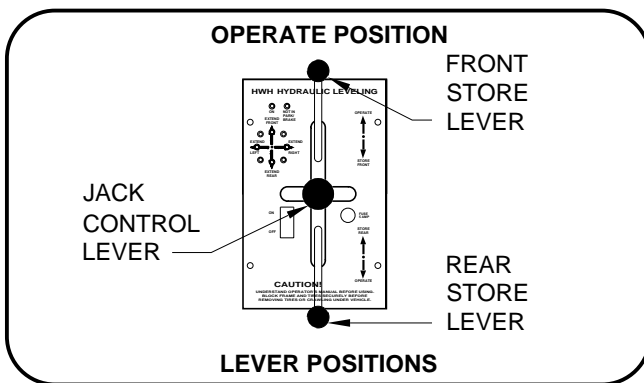

1. Place gear selector in the parking position, apply the park brake and block tires securely.

NOTE: If the hand/auto park brake is not set, the "NOT IN PARK/BRAKE" light will come on when the "ON/OFF" switch is on. The pump will not run if the park brake is not set.

2. Place the ignition switch in the "ACC" position. The vehicle's engine must be off. Running the engine during or after leveling may inflate the air suspension lifting the vehicle out of level.

3. Push the "ON/OFF" switch to the "ON" position. The POWER ON light will be lit.

4. If applicable, push and hold the AIR DUMP switch until all air is exhausted from the vehicle's suspension system.

NOTE: If the vehicle is equipped with a manual pilot air dump, the air should be exhausted from the suspension at this time. Refer to the vehicle manufacturer for instructions.

5. Move the FRONT and REAR STORE LEVERS to the OPERATE POSITION. Nothing should happen at this time. Place pads under jacks if necessary at this time.

NOTE: The respective red WARNING LIGHT will come on when a jack is extended approximately 1 inch.

6. A lit yellow LEVEL light indicates that the end, side or corner of the vehicle is low. Only one yellow LEVEL light should be lit at a time. If a corner of the vehicle is low, a side LEVEL light will be on by itself. Move the JACK CONTROL LEVER to the extend position to extend jack pairs corresponding to a lit yellow light. Extend jack pairs accordingly until all yellow lights are out. It may take several movements from side to front, or side to rear to raise a low corner. If the ground is too uneven, the jacks may not have enough stroke to level the vehicle. The vehicle may have to be moved.

7. After the vehicle is level, the jacks not used for leveling may be extended until they touch the ground. This provides additional stability against wind and activity in the vehicle. Do this by pushing the jack control lever to the rear and/or front as needed to extend any remaining jacks. Do not use the right or left extend positions. Jacks used to stabilize the vehicle should lift the vehicle approximately 3/4 of an inch.

8. Push the "ON/OFF" switch to the "OFF" position.

9. Turn the ignition switch off.

OPERATING PROCEDURES

RETRACT PROCEDURES

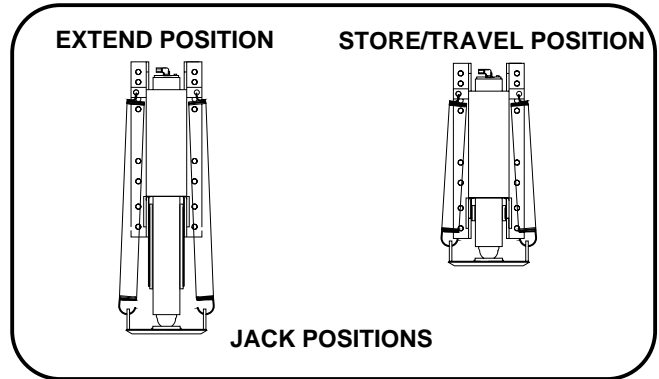
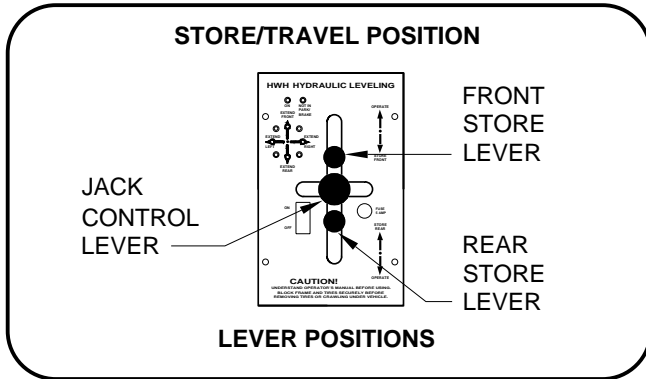

CAUTION: MAKE SURE THAT PEOPLE AND EQUIPMENT ARE CLEAR OF THE VEHICLE.

1. Start the vehicle engine and retract the jacks immediately. DO NOT move the vehicle until the vehicle is at the proper ride height for traveling.

NOTE: If applicable the vehicle suspension should be placed in the TRAVEL position at this time.

IMPORTANT: Always retract the front jacks first.

2. Move the STORE LEVERS to the STORE/TRAVEL POSITION. This will allow the jacks to retract.

CAUTION: THE STORE LEVERS SHOULD BE KEPT IN THE "STORE" POSITION WHILE TRAVELING TO KEEP THE JACKS IN THE STORE/TRAVEL POSITION.

3. Visually check that all jacks are in the STORE/TRAVEL position. With the ignition switch in the "ON" position, the red

WARNING lights, the master "JACKS DOWN" light and the buzzer should be off.

CAUTION: DO NOT MOVE THE VEHICLE WHILE THE LEVELING JACKS ARE STILL IN CONTACT WITH THE GROUND OR IN THE EXTEND POSITION. THIS VEHICLE IS EQUIPPED WITH STRAIGHT-ACTING JACKS. MOVING THE VEHICLE WITH THE LEVELING JACKS EXTENDED CAN CAUSE SEVERE DAMAGE TO THE JACKS AND OR THE VEHICLE AND CREATE A DRIVING HAZARD. DO NOT RELY SOLELY UPON WARNING LIGHTS. IT IS THE OPERATOR'S RESPONSIBILITY TO CHECK THAT ALL JACKS ARE FULLY RETRACTED INTO THE STORE/TRAVEL POSITION AND THE VEHICLE IS AT THE PROPER RIDE HEIGHT FOR TRAVELING.

4. Push the "ON/OFF" switch on the panel to the "OFF" position. Turn the ignition off or proceed to travel.

MAINTENANCE

OIL LEVEL

It is important that the four leveling jacks and all HWH room extensions are fully retracted before checking the oil level. To check the oil supply, remove the breather cap from the top of the hydraulic reservoir. The oil level should be approximately one inch below the top of the reservoir when adequately filled.

FLUID: HWH Specialty Hydraulic Oil is recommended. In an emergency Dexron automatic transmission fluid can be used.
NOTE: Dexron automatic transmission fluid contains red dye and can cause staining should a leak occur. **DO NOT USE** brake fluid or hydraulic jack fluid. Use of these can damage seals.

ELECTRICAL SYSTEM

The batteries should be in good condition and fully charged. All electrical connections, especially ground connections, should be clean, tight, free from corrosion and protected

from corrosion. Weak batteries can cause erratic operation. Battery cable terminals, battery posts and connections should be kept clean and protected from corrosion.

UNUSUAL CONDITIONS

If driving conditions are unusually muddy, the jacks may become caked or clogged with mud. This condition may hamper the proper operation of the leveling system. This problem may be prevented or remedied by cleaning off each leveling jack if they become excessively muddy.

Do not move the vehicle while the leveling jacks are still in contact with the ground. Place the system in the store mode and then visually check to see if the leveling jacks have returned to the STORE/TRAVEL position.

In wet or icy weather leveling jacks may become encrusted with ice. This may cause the leveling system to function improperly. To eliminate this problem, periodically check the leveling jacks and break loose any ice which may be causing improper operation.

NOTE: All major components of the system can be replaced with rebuilt parts or can be sent to HWH CORPORATION to be rebuilt, when the system is out of warranty.

LEVEL SENSING UNIT ADJUSTMENT

Level the vehicle by placing a circular bubble level in the center of the freezer floor or location within the vehicle that is to be level. With the vehicle level, adjust the sensing unit until all yellow lights are off. This is done by drawing up the corresponding screw if the sensing unit is mounted below the surface as shown or backing out the corresponding screw if the sensing unit is mounted above the surface. Bump the sensing unit to see that it is settled tight against all three screw heads and still indicates that the unit is level.

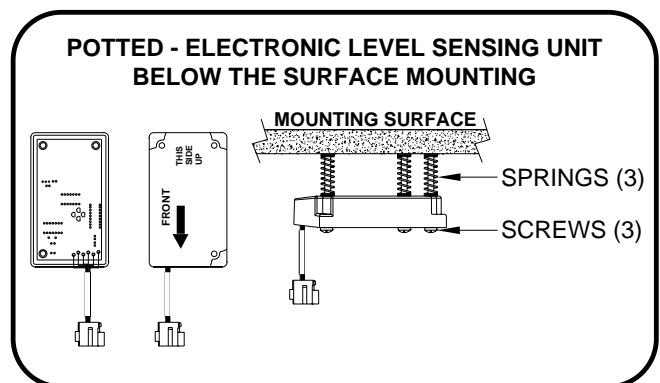

WINTER WEATHER DRIVING

Anti-icing / deicing agents when splashed on your vehicle, continue to absorb moisture from the air even after they have dried. This can facilitate corrosion of metallic components, such as HWH jacks.

To help reduce the corrosion of jacks after exposure to anti-icing / deicing agents, thoroughly wash jacks with warm soapy water.