

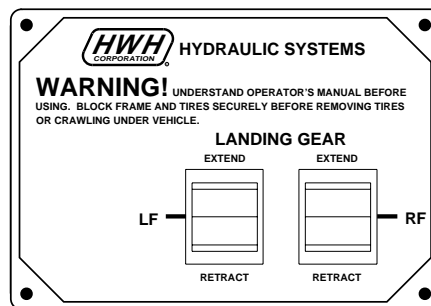

OPERATOR'S MANUAL

HWH® HYDRAULIC LANDING GEAR SYSTEM

FEATURING:
Two Double-Acting Jacks

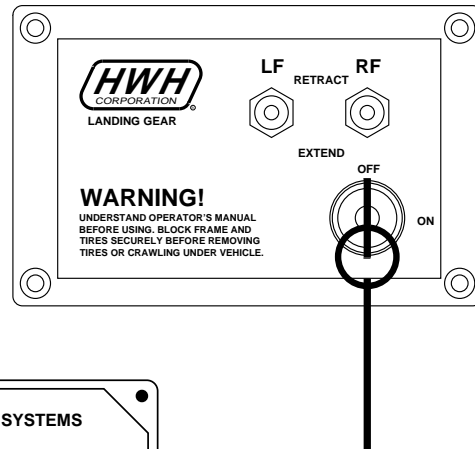
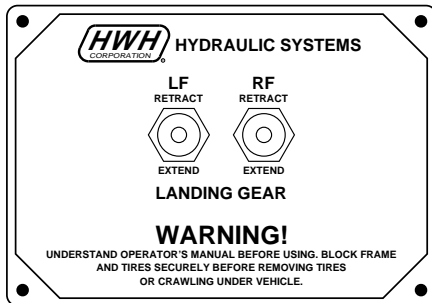

HWH CORPORATION
(On I-80, Exit 267 South)
2096 Moscow Road | Moscow, Iowa 52760
Ph: 800/321-3494 (or) 563/724-3396 | Fax: 563/724-3408
www.hwh.com

OPERATOR'S MANUAL

WARNING !

READ ENTIRE HWH AND VEHICLE OPERATOR'S MANUALS BEFORE OPERATING.

JACKS UNDER LOAD WILL RETRACT WHEN A JACK SOLENOID VALVE IS OPENED TO THE RETRACT POSITION WITHOUT THE PUMP RUNNING.

CHOCK TRAILER WHEELS SECURELY BEFORE USING THE LANDING GEAR.

DO NOT LIFT THE TOW VEHICLE WITH THE LANDING GEAR.

BLOCK FRAME AND TIRES SECURELY BEFORE CRAWLING UNDER THE TRAILER, CHANGING TIRES, OR ENTERING AREAS WHERE BODY MAY BE CRUSHED BY SUDDEN DROPPING OR SLIDING OF TRAILER.

THE TRAILER MAY DROP AND/OR MOVE FORWARD OR BACKWARD WITHOUT WARNING CAUSING INJURY OR DEATH.

NEVER PLACE HANDS OR OTHER PARTS OF THE BODY NEAR HYDRAULIC LEAKS. OIL MAY PENETRATE SKIN CAUSING INJURY OR DEATH.

WEAR SAFETY GLASSES WHEN INSPECTING OR SERVICING THE SYSTEM TO PROTECT EYES FROM DIRT, METAL CHIPS, OIL LEAKS, ETC. FOLLOW ALL OTHER APPLICABLE SHOP SAFETY PRACTICES.

IMPORTANT: IF COACH IS EQUIPPED WITH A ROOM EXTENSION, READ ROOM EXTENSION SECTION BEFORE OPERATING LEVELING SYSTEM.

HOW TO OBTAIN WARRANTY SERVICE

THIS IS NOT TO BE INTERPRETED AS A STATEMENT OF WARRANTY

HWH CORPORATION strives to maintain the highest level of customer satisfaction. Therefore, if you discover a defect or problem, please do the following:

FIRST: Notify the dealership where you purchased the vehicle or had the leveling system installed. Dealership management people are in the best position to resolve the problem quickly. If the dealer has difficulty solving the problem, he should immediately contact the Customer Service Department, at HWH CORPORATION.

SECOND: If your dealer cannot or will not solve the problem, notify the Customer Service Department:
HWH CORPORATION 2096 Moscow Rd. Moscow IA. 52760
(563) 724-3396 OR (800) 321-3494. Give your name and address, coach manufacturer and model year, date the coach was purchased, or the date of system installation,

description of the problem, and where you can be reached during business hours (8:00 a.m. till 5:00 p.m. c.s.t.). HWH CORPORATION personnel will contact you to determine whether or not your claim is valid. If it is, HWH CORPORATION will authorize repair or replacement of the defective part, either by appointment at the factory or by the authorization of an independent service facility, to be determined by HWH CORPORATION. All warranty repairs must be performed by an independent service facility authorized by HWH CORPORATION, or at the HWH CORPORATION factory, unless prior written approval has been obtained from proper HWH CORPORATION personnel.

OPERATING PROCEDURES

GENERAL INSTRUCTIONS

Maintain adequate clearance in all directions for vehicle, room extensions, awnings, doors, steps, etc. Vehicle may move in any direction due to landing gear extending or retracting, settling of the landing gear or the vehicle, equipment malfunction, etc..

If parking on soft ground or asphalt paving, a wood block or pad should be placed under the jacks.

WARNING: DO NOT MOVE THE VEHICLE IF ONE OR MORE LANDING GEAR ARE EXTENDED TO THE GROUND.

PREPARATION FOR TRAVEL

Any room extension should be fully retracted before traveling.

WARNING: DO NOT MOVE THE VEHICLE WHILE THE LANDING GEAR JACKS ARE STILL IN CONTACT WITH THE GROUND OR IN THE EXTENDED POSITION. THIS VEHICLE IS EQUIPPED WITH STRAIGHT- ACTING LANDING GEAR JACKS. MOVING THE VEHICLE WITH THE LANDING GEAR JACKS EXTENDED CAN CAUSE SEVERE DAMAGE TO THE LANDING GEAR JACKS AND

OR THE VEHICLE AND CREATE A DRIVING HAZARD. IT IS THE OPERATOR'S RESPONSIBILITY TO CHECK THAT ALL LANDING GEAR JACKS ARE FULLY RETRACTED INTO THE STORE/TRAVEL POSITION.

If the landing gear jacks cannot be extended or retracted according to the SET UP or PREPARATION FOR TRAVEL procedures, refer to the AUXILIARY HAND PUMP procedures.

ROOM EXTENSION PROCEDURES

IMPORTANT: If the vehicle is equipped with a room extension read this section carefully.

IMPORTANT: It is recommended to level and stabilize the vehicle before extending the room.

IMPORTANT: Extending or retracting any leveling jacks or landing gear when the room is extended is not recommended.

Refer to the vehicle owner's manual for proper operation of room extensions.

IMPORTANT: Do not use a room extension support when the vehicle is supported by the landing gear system.

OPERATING PROCEDURES

SET UP PROCEDURE

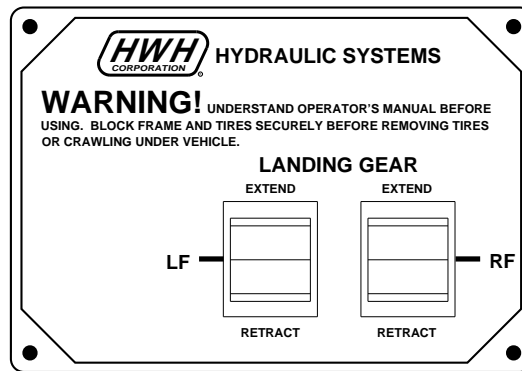
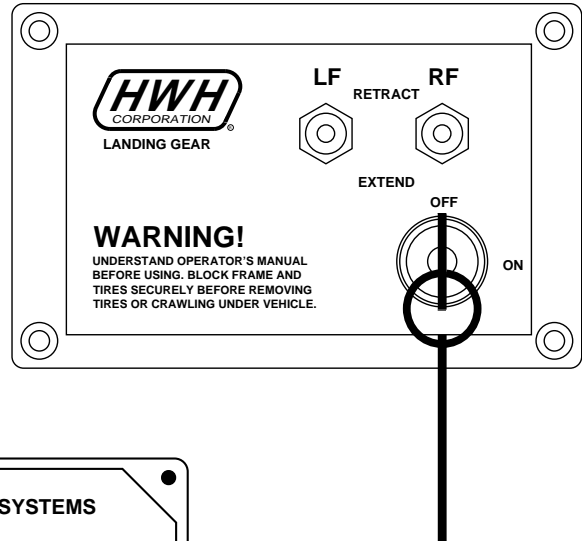
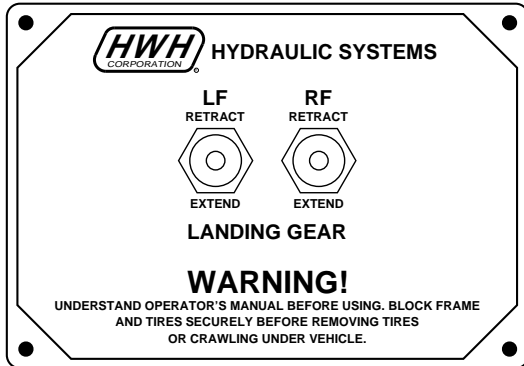

WARNING: DO NOT STAND BETWEEN THE TOW VEHICLE AND THE TRAILER OR BEHIND THE TRAILER WHEN UNHITCHING THE TRAILER OR OPERATING THE HWH LANDING GEAR.

If parking on soft ground or asphalt paving, a wood block or pad should be placed under the jacks.

NOTE: There is an operating switch for each landing gear jack. Each can be operated individually by moving one switch only. IT IS RECOMMENDED TO OPERATE BOTH JACKS AT THE SAME TIME WHEN UNHITCHING, LIFTING OR SUPPORTING THE TRAILER WITH THE LANDING GEAR.

1. Refer to the trailer manufacturer for instructions on unhitching the trailer from the tow vehicle.
2. If applicable, turn the panel key switch to "ON".
3. Push and hold the landing gear switch(es) to the extend position.
4. When the landing gear and trailer are in the desired position, release the operating switch.
5. If applicable, turn the panel key switch to "OFF".

In the case of a power failure or pump failure, the landing gear can be extended to hitch or unhitch the trailer. See "AUXILIARY HAND PUMP" operating procedures.

OPERATING PROCEDURES

PREPARATION FOR TRAVEL

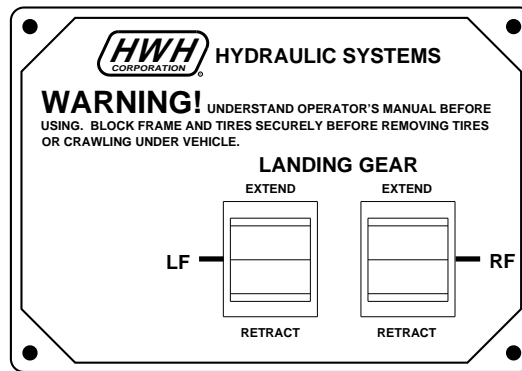
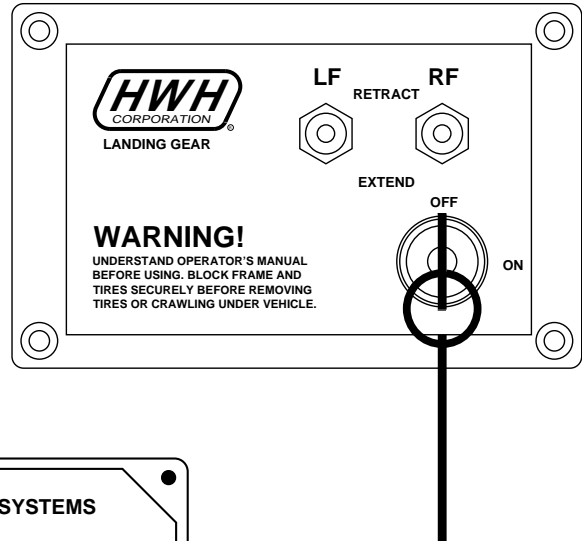
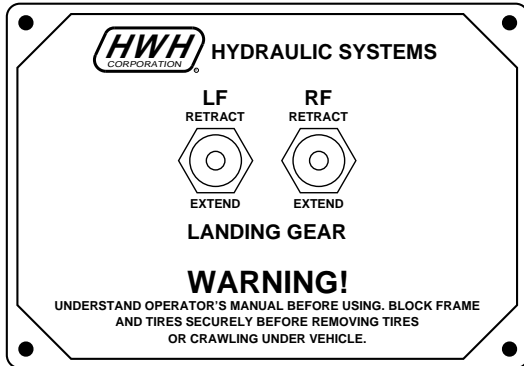

WARNING: DO NOT STAND BETWEEN THE TOW VEHICLE AND THE TRAILER OR BEHIND THE TRAILER WHEN UNHITCHING THE TRAILER OR OPERATING THE HWH LANDING GEAR.

The trailer can be hitched to the tow vehicle by pushing the "LANDING GEAR" switches to the retract positions.

If, applicable, the panel key switch must be "ON" to operate the landing gear.

1. Hitch the trailer to the tow vehicle according to the trailer manufacturer's instructions.

NOTE: It is recommended to operate both switches at the same time while lowering the trailer. This will reduce twisting of the trailer.

2. When the trailer is securely hitched to the tow vehicle push and hold the "LANDING GEAR" switches to the retract positions until the jacks have retracted to the full store position.

3. Release the switches when the landing gear are fully retracted.

NOTE: Do Not hold the "LANDING GEAR" switches for more than 10 seconds after the jacks are fully retracted.

4. If, applicable, turn the panel key switch "OFF".

WARNING: DO NOT MOVE THE VEHICLE WHILE THE LANDING GEAR JACKS ARE STILL IN CONTACT WITH THE GROUND OR IN THE EXTENDED POSITION. THIS VEHICLE IS EQUIPPED WITH STRAIGHT- ACTING LANDING GEAR JACKS. MOVING THE VEHICLE WITH THE LANDING GEAR JACKS EXTENDED CAN CAUSE SEVERE DAMAGE TO THE LANDING GEAR JACKS AND OR THE VEHICLE AND CREATE A DRIVING HAZARD. IT IS THE OPERATOR'S RESPONSIBILITY TO CHECK THAT ALL LANDING GEAR JACKS ARE FULLY RETRACTED INTO THE STORE/TRAVEL POSITION.

If the landing gear jacks cannot be extended or retracted to PREPARATION FOR TRAVEL procedures, refer to the "AUXILIARY HAND PUMP" procedures in this manual.

OPERATING PROCEDURES

AUXILIARY HAND PUMP OPERATION

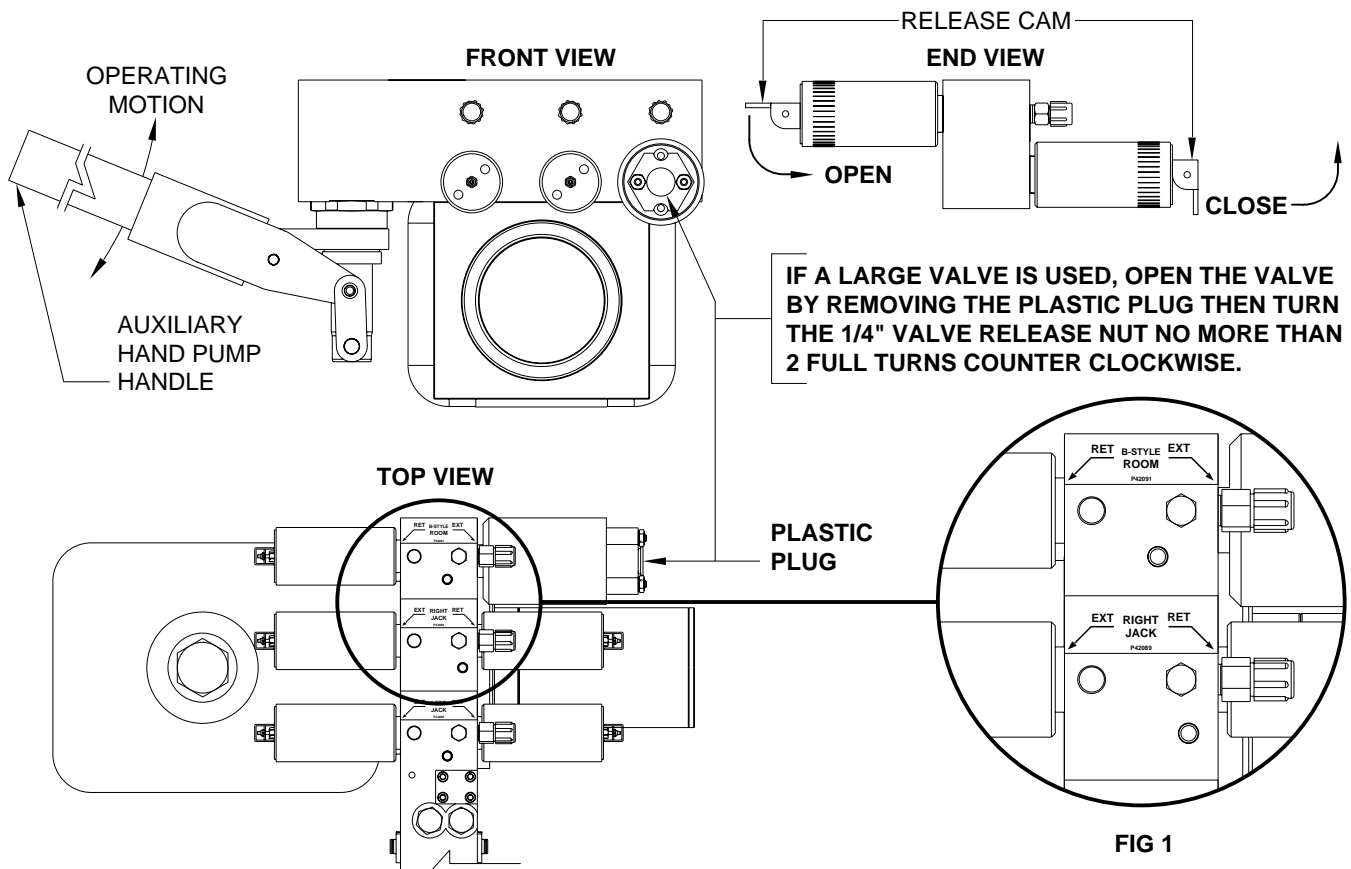

FIG 1

NOTE: Each hydraulic function requires a pair of solenoid valves one each for the extend and retract procedures. The number of functions and the items controlled by each pair of solenoid valves will vary for each system. The diagrams shown on this page represent a (3) function system of (2) jacks and (1) room as indicated by the labels shown in FIG 1. Use the labels specific to your system when following these procedures. Room control solenoid valves may be located at the synchronizing cylinder, not on the pump manifold.

The auxiliary hand pump can be used to extend or retract the landing gear, jacks or room extensions anytime the pump will not function.

The auxiliary hand pump is a two stage pump that will produce enough pressure to extend the landing gear and lift the vehicle as well as retract the landing gear. When operating the auxiliary pump to lift the vehicle or when the jacks are fully retracted, the pump handle will seem to "snap" as the pump goes to the second stage. The pumping action will be easier at first as the second stage starts to create more pressure.

NOTE: The hand pump will swivel to any position which will ease the operation of the hand pump.

To operate the auxiliary hand pump, open the appropriate solenoid valve. Insert the hand pump handle into the handle receptacle and move the handle in an up and down motion.

NOTE: If a room cannot be retracted using the auxiliary hand pump, see "MANUAL ROOM RETRACTION PROCEDURES".

WARNING: THE VEHICLE SHOULD BE SUPPORTED BY AUXILIARY STANDS OR SECURELY HITTED TO THE TOW VEHICLE BEFORE OPENING ANY VALVES.

The auxiliary hand pump may work easier if only one valve is open at a time. **Be careful to not twist the vehicle if only one solenoid valve is open.**

IMPORTANT: FOLLOW THE "SET UP" AND "PREPARATION FOR TRAVEL" PROCEDURES WHEN USING THE AUXILIARY HAND PUMP.

It is recommended to operate the auxiliary hand pump occasionally to check its operation.

IMPORTANT: ONLY MOVE THE RELEASE CAM IN THE DIRECTION SHOWN. MOVING THE CAM IN THE OPPOSITE DIRECTION CAN DAMAGE THE VALVES.

MAINTENANCE

PRIMING THE HAND PUMP

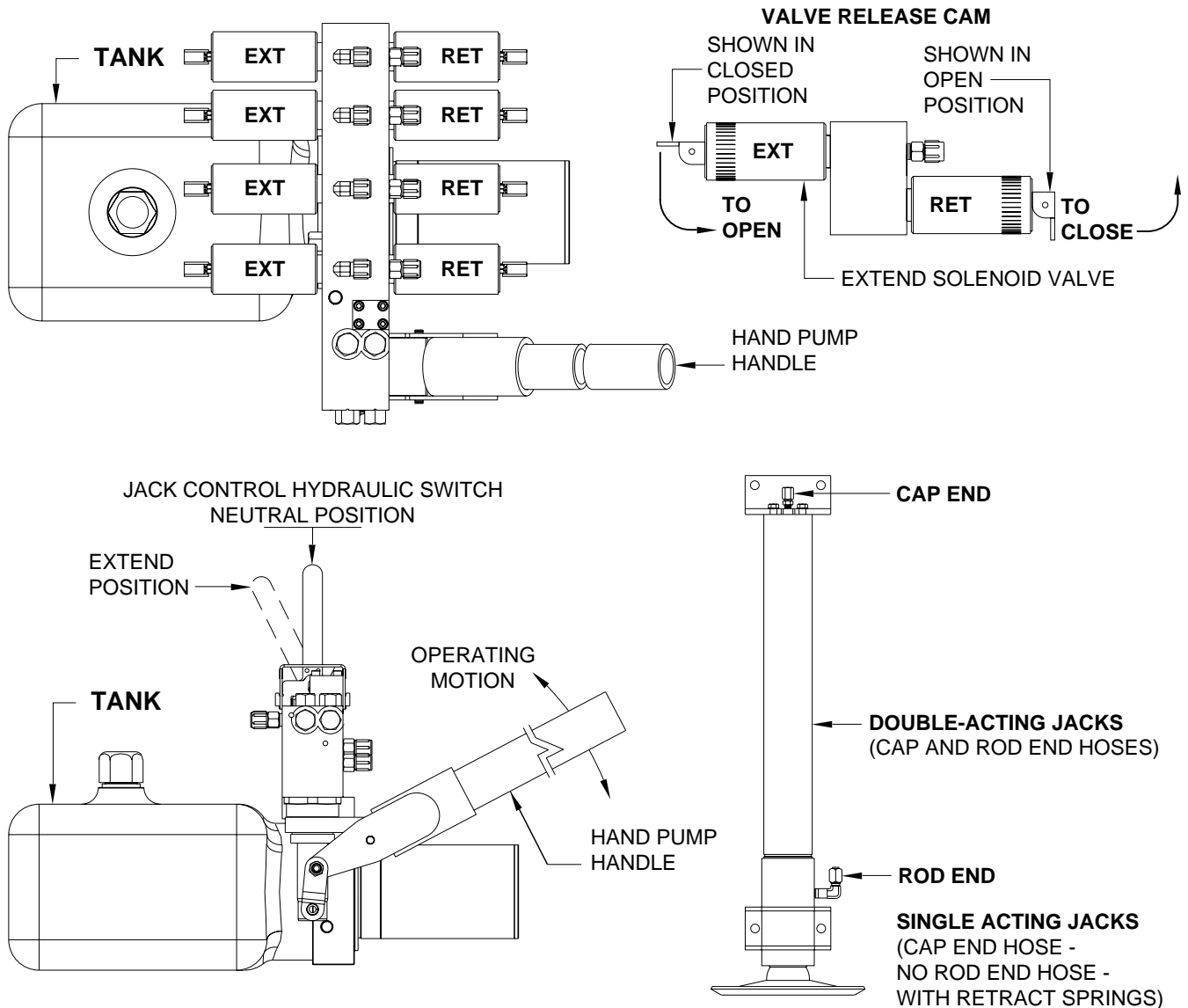

To prime the hand pump, it will be necessary to remove a hose from one of the jacks. One of the front jacks would be best, but use the easiest hose to get to.

If the system has Double-Acting cylinders on the front, remove the rod end hose from either of the front jacks. Place the end of the hose in a bucket. Make sure the tank is at least half full. Pump the hand pump until a healthy flow of oil is coming from the hose.

IMPORTANT: DO NOT ALLOW THE FLUID LEVEL IN THE TANK TO LOWER MORE THAN 1 INCH BEFORE ADDING FLUID.

Reattach the hose and retry the hand pump. Repeat the procedure if the hand pump does not move the jacks.

If the system has only Single-Acting jacks with return springs, remove the easiest hose to access and place the end in a bucket. Using the release cam, manually open the EXTEND solenoid valve for that jack (if equipped with solenoid valves) or move the jack control hydraulic switch to "EXTEND" for that jack. Make sure the tank is at least half full. Pump the hand pump until a healthy flow of fluid comes from the hose.

IMPORTANT: DO NOT ALLOW THE FLUID LEVEL IN THE TANK TO LOWER MORE THAN 1 INCH BEFORE ADDING FLUID.

Reattach the hose and retry the hand pump. Repeat the procedure if the hand pump does not move the jacks.

HYDRAULIC LINE CONNECTION DIAGRAM

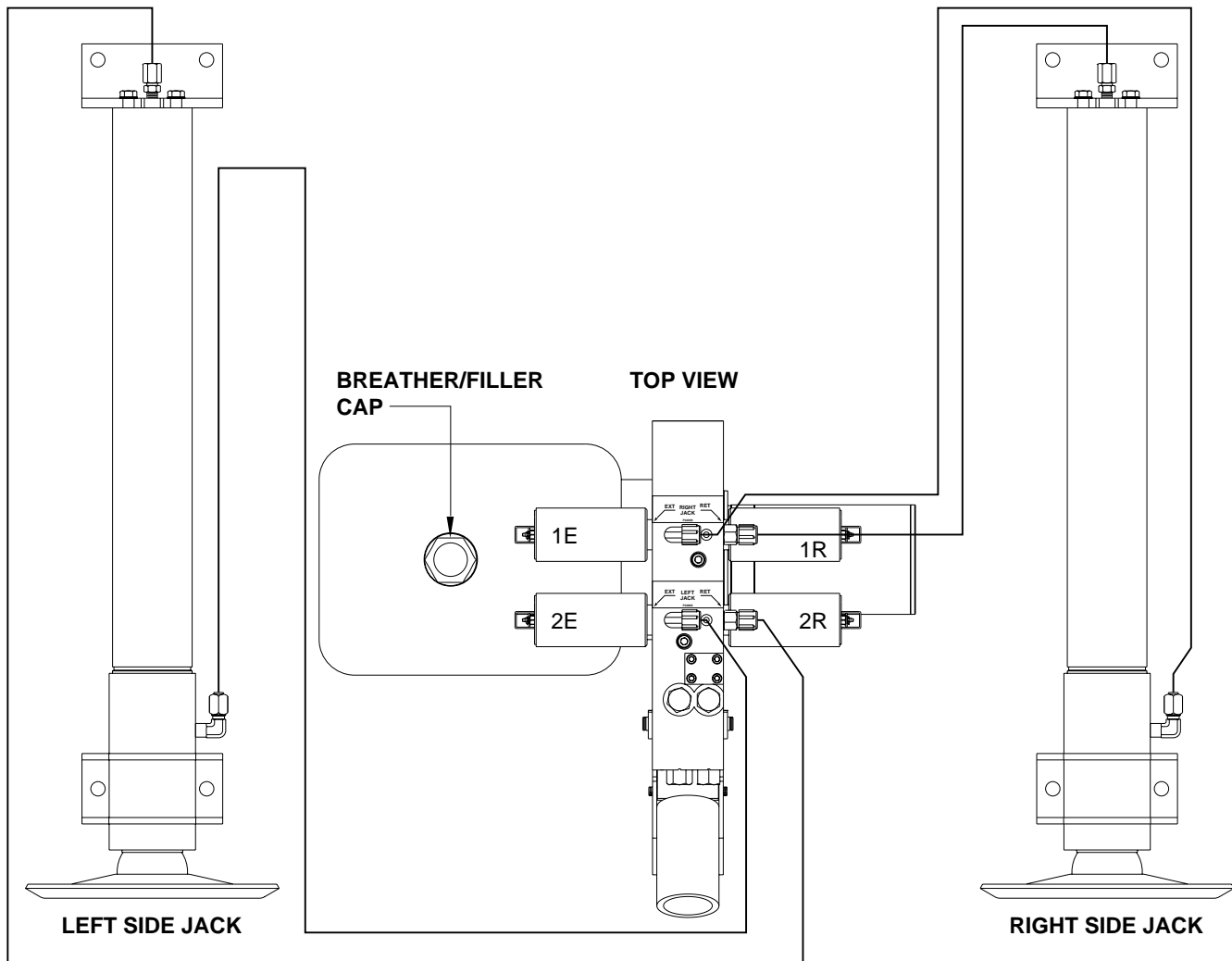

1E - RIGHT SIDE LANDING GEAR EXTEND VALVE
1R - RIGHT SIDE LANDING GEAR RETRACT VALVE
2E - LEFT SIDE LANDING GEAR EXTEND VALVE
2R - LEFT SIDE LANDING GEAR RETRACT VALVE