

OPERATING PROCEDURES

UNIVERSAL LEVEL IN/LEVEL OUT ROOM EXTENSION MECHANISM

MANUAL ROOM RETRACTION PROCEDURES - SPLINED TORSION SHAFT

PAGE 1 OF 2

In the event of a hydraulic failure, including the hand pump, if so equipped, the room and floor can be manually retracted.

IMPORTANT: KEEP PEOPLE CLEAR OF THE ROOM WHEN MANUALLY RETRACTING THE ROOM. MAKE SURE THERE ARE NO OBJECTS SUCH AS CARPET, CHAIRS, ETC. BLOCKING OR INTERFERING WITH THE MOVEMENT OF THE FLOOR OR ROOM.

To manually retract room, first the floor must be completely lowered. The floor raise / lower mechanism must be accessed to accomplish this. An area closest to the floor lift cylinder is the best area to use. A spline wrench which will be needed to turn the main mechanism spline shaft is wire tied to the main floor lift cylinder.

1. Determine which extend and retract solenoid valves are assigned to the room. Open both valves by moving the valve release cam to the open position as shown in the following diagram. If the correct valves cannot be identified, open all room control valves. Do not open any jack control valves.

IMPORTANT: ONLY MOVE THE RELEASE CAM IN THE DIRECTION SHOWN. MOVING THE CAM IN THE OPPOSITE DIRECTION CAN DAMAGE THE VALVES.

2. Locate the pressure control valve. This valve must be opened to lower the floor. The pressure control valve is wire tied to the synchronizing cylinder or mounted directly to the main floor lift cylinder. (See the hydraulic diagram or contact HWH Corporation) The end of the valve has a 1/4" release nut. Use a 1/4" nut driver to turn the nut 4 & 1/2" turns counterclockwise. DO NOT turn the nut more than 5 turns or damage to the valve can occur.

3. Access the splined shaft as close to the main floor lift cylinder as possible. (See floor lift mechanism diagram.)

4. Use the spline wrench provided, to rotate the splined shaft in the direction shown in the floor lift mechanism diagram. The floor lift cylinder should extend as the floor lowers to the store position.

5. When the floor is completely lowered, the room can be retracted. Proceed to page 2 for manual room retraction instructions.

NOTE: The floor should not be raised hydraulically or manually until the system has been serviced.

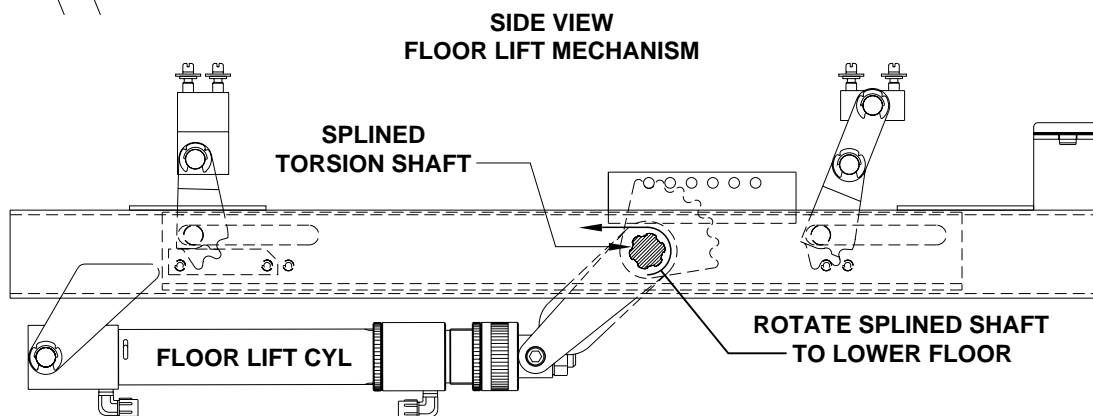
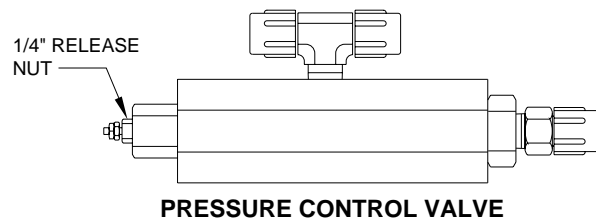
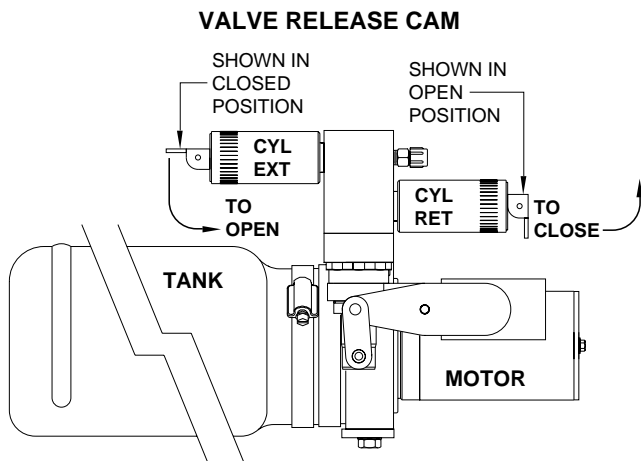

OPERATING PROCEDURES

UNIVERSAL LEVEL IN/LEVEL OUT ROOM EXTENSION MECHANISM

MANUAL ROOM RETRACTION PROCEDURES - SPLINED TORSION SHAFT

PAGE 2 OF 2

1. After the floor is completely lowered, the room can be retracted. Leave the floor solenoid valves open and proceed to step 2.

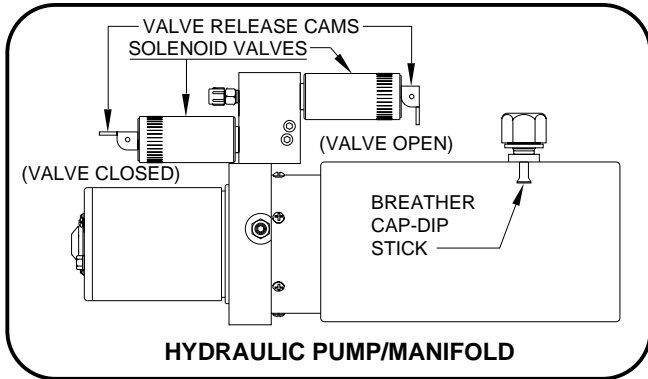

2. Locate and open both solenoid valves for the room mechanism.

3. Start both threaded rods until resistance is met, one for the front and one for the rear mechanism should be provided.

NOTE: To access the threaded blocks refer to vehicle manufacturer.

4. **Do Not use an impact wrench.** Using wrench provided, a personal wrench or a tire iron with a 1-1/8" opening rotate either mechanism's threaded rod clockwise 6 complete turns.

5. Move to the other room extension mechanism, rotate the threaded rod clockwise 12 complete turns.

6. Return to the first room extension mechanism and rotate the threaded rod clockwise 12 complete turns.

7. Repeat steps 4 and 5 alternating from mechanism to mechanism rotating each threaded rod 12 complete turns until room is sealed. (DO NOT exceed 15 ft.lbs) Make sure the room does not bind.

IMPORTANT: If at any stage something is not understood or if the room begins to bind DO NOT force the room, contact HWH Customer Service for assistance 1-800-321-3494.

NOTE: Leave the solenoid valves open and the threaded rods in place until the room has been serviced.

IMPORTANT: DO NOT EXTEND THE ROOM UNTIL THE ROOM HAS BEEN SERVICED. ANY SOLENOID VALVES LEFT OPEN SHOULD BE CLOSED AND THE THREADED RODS SHOULD BE COMPLETELY REMOVED.

NOTE: If there is not enough room to remove both threaded rods completely, alternate backing the threaded rods out and slightly extending the room. Be careful to not extend the room so far that the threaded rods impact the coach wall or the mechanism.

