



HWH[®] Sprinter Leveling System With HWH[®] Aftermarket Brackets

Automatic leveling for RVs built on the popular Sprinter Chassis

Owners of Class B RVs built on the Sprinter Chassis can enjoy the benefits of computer-controlled, automatic leveling used for Class A and bus-style RVs. The single-step touch panel is easy to operate and the telescoping jacks are specifically designed to fit this chassis' low-profile design. The jacks are very compact with a long 13" stroke.

Easy To Install - No Welding - Clamp On Design

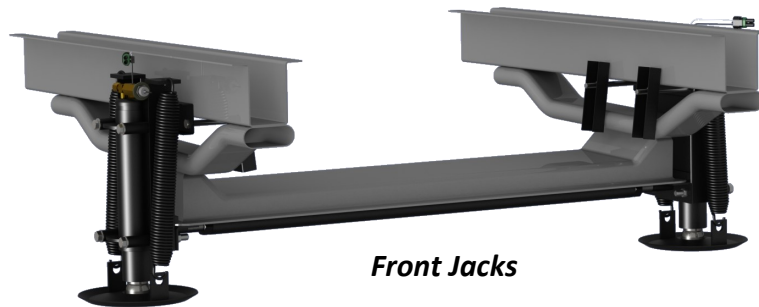

Rear jacks can be mounted Inboard or Outboard

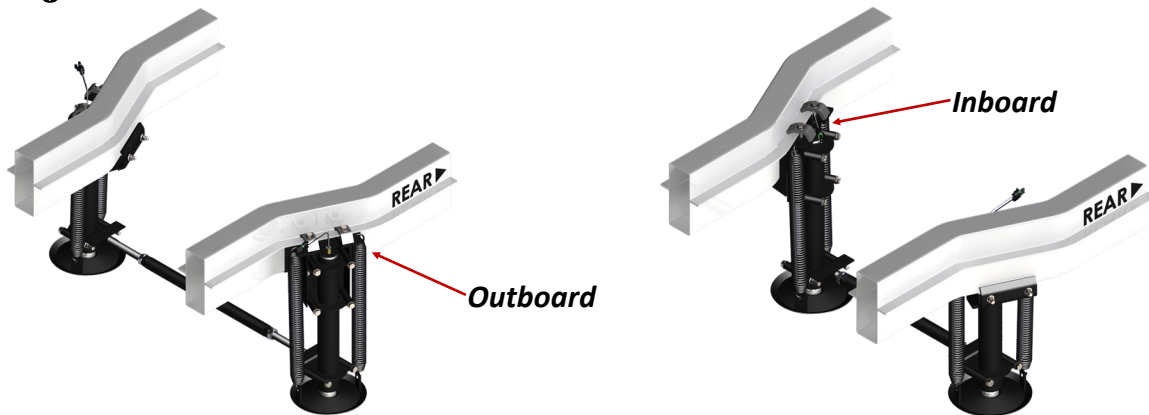

AP52393 725 Series HWH[®] Leveling System

- 4,000 lb. Straight-Acting (Power-Extend/Spring-Retract) Telescoping Jacks on the front
- 6,000 lb. Straight-Acting (Power-Extend/Spring-Retract) Jacks for the rear

Single-Step Leveling



Exclusive HWH[®] 4-Point
BI-AXIS[®] Leveling



Improving Your RV Experience 1967

2096 Moscow Road, Moscow, IA 52760 | Phone: 800-321-3494 | Fax: 563-724-3408 | www.HWH.com

Specifications & Features

HWH® Brackets Made Special for the 3500 Sprinter Chassis

Front Jacks



Specifications for Front Jacks	
Stroke (inches)	13
Frame to Foot (inches) adjustable	12.071 or 13.321
Weight (pounds) includes jack, crosstie and mounting hardware	45.26

Rear Jacks



Rear Jacks Mounted Inboard-----OR-----Rear Jacks Mounted Outboard

Specifications for Rear Jacks	
Stroke (inches)	13
Frame to Foot (inches) adjustable	13.803 or 15.303
Weight (pounds) includes jack, crosstie and mounting hardware	50.10

Complete kit weight - 170 pounds.