



# OPERATOR'S MANUAL

## 2000 SERIES, COMPUTER-CONTROLLED HYDRAULIC LEVELING SYSTEM

### FEATURING:

- BI-AXIS<sup>®</sup> Touch Panel Control*
- 4 - Straight-Acting (Power-Extend/Power-Retract) Jacks*
- 1 - SpaceMaker<sup>®</sup> Single-Cylinder Guided Slide-Out*
- 1 - SpaceMaker<sup>®</sup> Dual-Cylinder In-Floor Slide-Out*
- Swivel Manual/Hand Pump Back-Up*
- Suspension Air Dump*

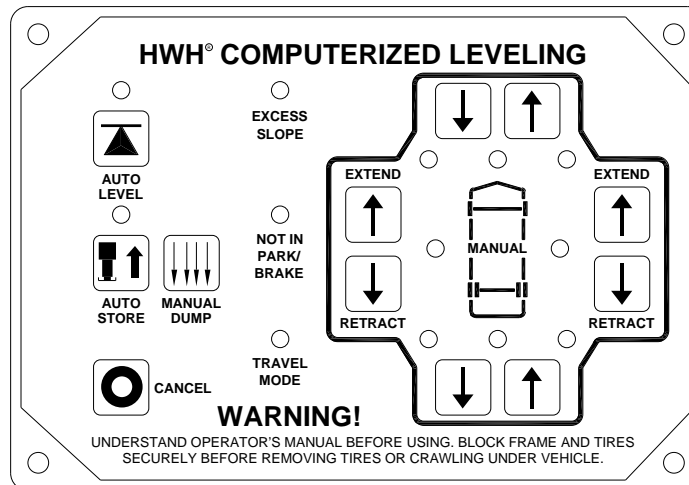

**HWH CORPORATION**  
(On I-80, Exit 267 South)  
2096 Moscow Road | Moscow, Iowa 52760  
Ph: 800/321-3494 (or) 563/724-3396 | Fax: 563/724-3408  
[www.hwh.com](http://www.hwh.com)

---

# OPERATOR'S MANUAL

---

## WARNING !

READ THE ENTIRE OPERATOR MANUAL BEFORE OPERATING.

**BLOCK FRAME AND TIRES SECURELY BEFORE CRAWLING UNDER VEHICLE. DO NOT USE LEVELING JACKS OR AIR SUSPENSION TO SUPPORT VEHICLE WHILE UNDER VEHICLE OR CHANGING TIRES. VEHICLE MAY DROP AND/OR MOVE FORWARD OR BACKWARD WITHOUT WARNING CAUSING INJURY OR DEATH.**

**KEEP ALL PEOPLE CLEAR OF VEHICLE WHILE OPERATING LEVELING SYSTEM OR ROOM EXTENSIONS.**

**KEEP ALL PEOPLE CLEAR OF VEHICLE WHILE DUMPING AIR FROM THE VEHICLE'S SUSPENSION.**

**DO NOT MOVE THE VEHICLE IF THE VEHICLE IS NOT AT THE PROPER RIDE HEIGHT. CONTACT MANUFACTURER TECHNICAL SERVICE FOR MOVING THE VEHICLE WHEN NOT AT THE PROPER RIDE HEIGHT.**

**WEAR SAFETY GLASSES WHEN INSPECTING OR SERVICING THE SYSTEM TO PROTECT EYES FROM DIRT, METAL CHIPS, OIL LEAKS, ETC. FOLLOW ALL OTHER APPLICABLE SHOP SAFETY PRACTICES.**

**IMPORTANT: IF COACH IS EQUIPPED WITH A ROOM EXTENSION, READ ROOM EXTENSION SECTION BEFORE OPERATING LEVELING SYSTEM.**

## HOW TO OBTAIN WARRANTY SERVICE

### THIS IS NOT TO BE INTERPRETED AS A STATEMENT OF WARRANTY

HWH CORPORATION strives to maintain the highest level of customer satisfaction. Therefore, if you discover a defect or problem, please do the following:

**FIRST:** Notify the dealership where you purchased the vehicle or had the leveling system installed. Dealership management people are in the best position to resolve the problem quickly. If the dealer has difficulty solving the problem, he should immediately contact the Customer Service Department, at HWH CORPORATION.

**SECOND:** If your dealer cannot or will not solve the problem, notify the Customer Service Department:  
HWH CORPORATION 2096 Moscow Rd. Moscow IA. 52760  
(563) 724-3396 OR (800) 321-3494. Give your name and address, coach manufacturer and model year, date the coach was purchased, or the date of system installation,

description of the problem, and where you can be reached during business hours (8:00 a.m. till 5:00 p.m. c.s.t.). HWH CORPORATION personnel will contact you to determine whether or not your claim is valid. If it is, HWH CORPORATION will authorize repair or replacement of the defective part, either by appointment at the factory or by the authorization of an independent service facility, to be determined by HWH CORPORATION. All warranty repairs must be performed by an independent service facility authorized by HWH CORPORATION, or at the HWH CORPORATION factory, unless prior written approval has been obtained from proper HWH CORPORATION personnel.

# CONTROL IDENTIFICATION

## 625 / 725 / 2000 SERIES LEVELING SYSTEM

### COMPUTER-CONTROL

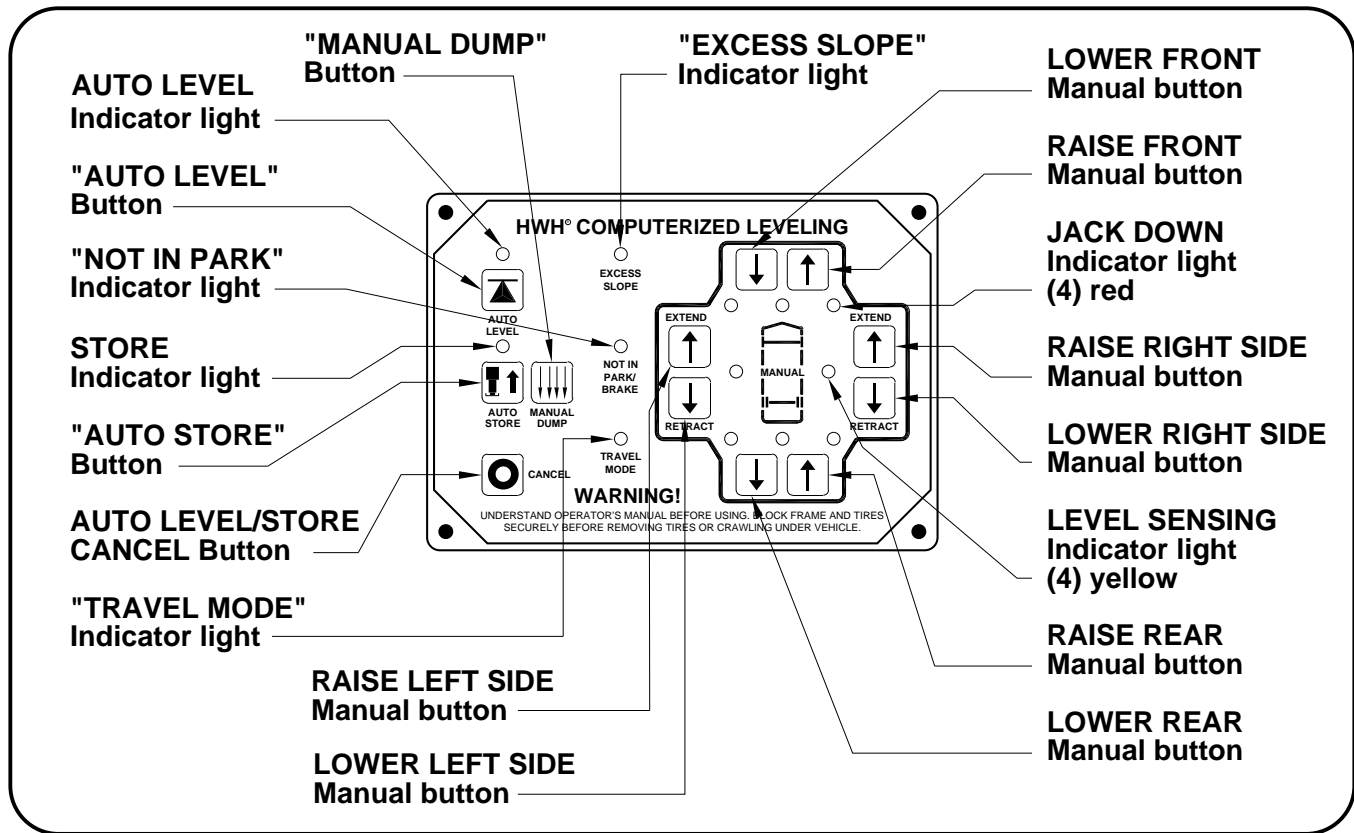

## CONTROL FUNCTIONS

### CONTROL BUTTONS

**"CANCEL" BUTTON:** Push this button to stop any leveling system operation.

**"AUTO LEVEL" BUTTON:** Push this button any time to start the automatic leveling function.

**"AUTO STORE" BUTTON:** Push this button to retract all four jacks at the same time.

**"MANUAL DUMP" BUTTON:** This is a manual button for dumping air from the vehicle suspension.

**EXTEND BUTTONS (UP ARROWS):** These buttons will extend their respective jack pairs to lift the vehicle.

**RETRACT BUTTONS (DOWN ARROWS):** These buttons will retract their respective jack pairs to lower the vehicle.

### INDICATOR LIGHTS

**AUTO LEVEL INDICATOR LIGHT:** This light will flash during the automatic leveling function.

**STORE INDICATOR LIGHT:** This light will flash during the automatic store function.

**"NOT IN PARK/BRAKE" LIGHT:** This indicator will light when the hand/auto brake is not set and the "AUTO LEVEL" button is being pushed.

### INDICATOR LIGHTS (CONTINUED)

**LEVELING LIGHTS:** The four yellow indicating lights are level sensing indicators. When a yellow light is on, it indicates that its side, end, or corner of the vehicle is low. No more than two lights should be on at the same time. When all four yellow LEVEL lights are out, the vehicle is level.

**WARNING LIGHTS:** The four red lights surrounding the yellow level indicators are jacks down WARNING lights. They are functional only when the ignition is in the "ON" or "ACC" position, the system is on, and the jacks are extended 1/4 to 1/2 inch.

**"EXCESS SLOPE" LIGHT:** This indicator will light when the leveling system cannot level the vehicle.

**"TRAVEL MODE" LIGHT:** This indicator light will be on when the ignition is on, when the jacks are retracted and there are no red WARNING lights on.

**MASTER "JACKS DOWN" WARNING LIGHT:** This is a light mounted in the dash separate from the touch panel. It will be on when any one or more jacks are extended and the ignition is "ON".

**BUZZER:** This is a jacks down warning. It will sound if the master "JACKS DOWN" warning light is on.

## CONTROL IDENTIFICATION

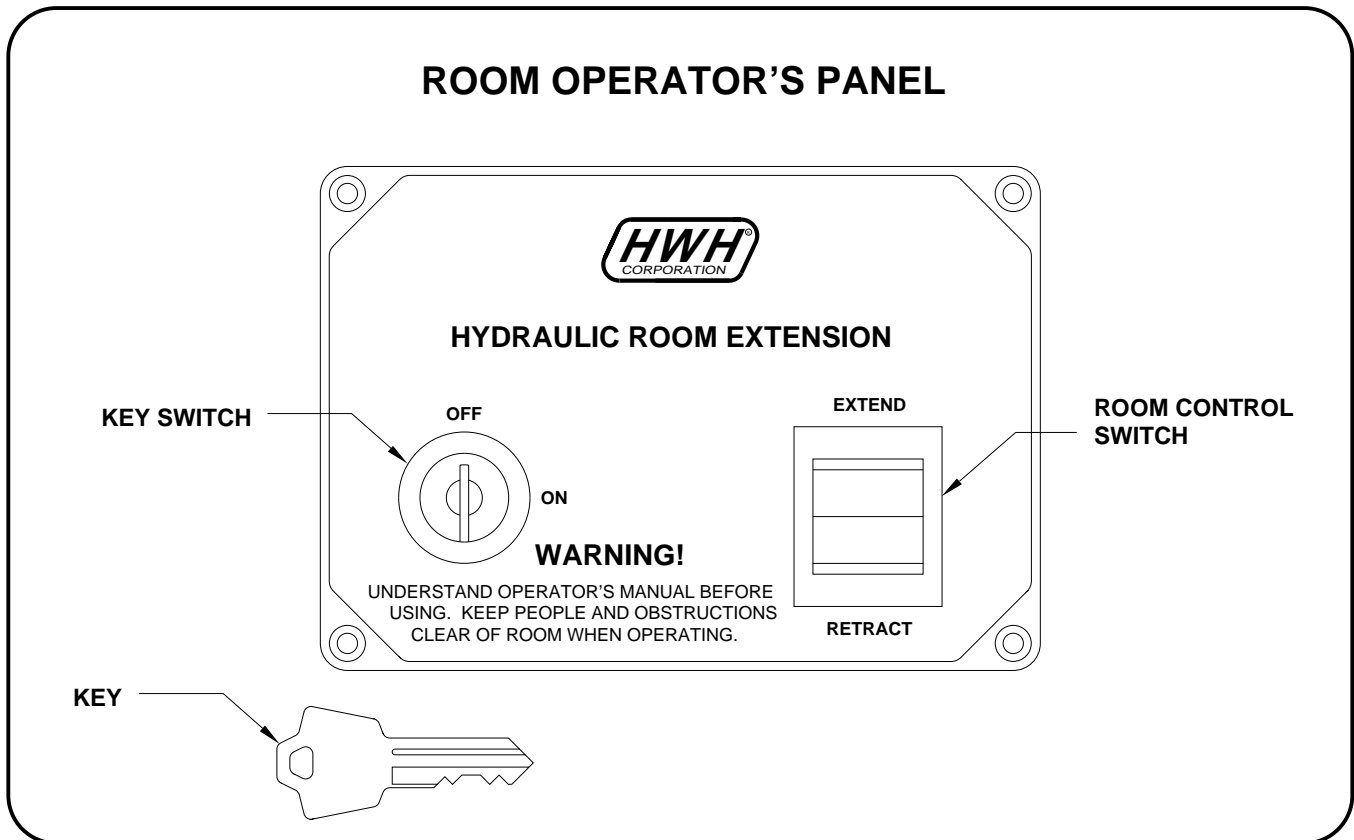

## CONTROL FUNCTIONS

**KEY SWITCH:** The KEY SWITCH controls power to the ROOM CONTROL SWITCH. When the KEY SWITCH is in the "ON" POSITION the room can be operated, and the key cannot be removed. When the KEY SWITCH is in the "OFF" position the room cannot be operated, and the key can be removed.

**ROOM CONTROL SWITCH:** The ROOM CONTROL SWITCH is a two position momentary switch. Pressing the switch in the EXTEND POSITION will extend the room. Pressing the switch in the RETRACT POSITION will retract the room. Releasing the ROOM CONTROL SWITCH will halt the operation of the room.

---

# CONTROL IDENTIFICATION

## PUMP RUN TIME

---

### PUMP RUN TIME

Pump motors used with HWH leveling systems and room extension systems come in 3 different diameters; 3", 3.7" and 4.5". Contact the vehicle manufacturer or HWH for help with identifying the motor size. **It is important that any time the pump runs for more than three minutes with a 3" motor; or six minutes with a 3.7" or 4.5" motor that the motor is allowed to cool for thirty minutes before continuing. Continuous operation of the pump motor without allowing the motor to cool can damage the motor.** For cold weather information see "COLD WEATHER OPERATIONS" below.

The HWH systems with a computer processor monitor the pump run time and will turn the pump off if the run time exceeds a specified time. This time can vary with different systems. Due to available electronics or system design, the pump run time programs will also vary. Leveling systems and room extensions that are not controlled by a system processor have no pump run time protection. **DO NOT run the pump more than three or six minutes without allowing the pump motor to cool for thirty minutes.**

#### SYSTEM VARIATIONS FOR PUMP RUN TIME

Some systems with rooms run the rooms separate from the system processor. These systems do not monitor pump run time when operating the rooms. **DO NOT run the pump more than three or six minutes without allowing the pump motor to cool for thirty minutes.**

Some systems can be turned back on immediately after the processor turns the pump off. **DO NOT turn the system back on or run the pump without allowing the pump motor to cool for thirty minutes.**

When operating some leveling systems manually or operating the room extensions, the pump will turn off and back on while pushing the control button when the pump run time has been exceeded. **DO NOT continue without allowing the pump motor to cool for thirty minutes.**

With some systems, when the processor has turned the pump off because the run time has been exceeded, power to the HWH system must be turned off and back on before the system will operate. With motorized vehicles, turn the ignition off and back on. With non-motorized vehicles, turn the master power switch for the HWH system off and back on. **DO NOT continue without allowing the pump motor to cool for thirty minutes.**

Some HWH systems are equipped with a lighted reset switch. If the processor turns the pump off because the run time has been exceeded, the light in the reset switch will turn on. The system will not operate until the reset switch is pushed.

**DO NOT continue without allowing the pump motor to cool for thirty minutes.**

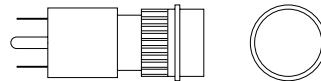

LIGHTED RESET SWITCH

**No matter what HWH system is on the vehicle, the pump should not be ran for more than three minutes (3" motors) or six minutes (3.7" or 4.5" motors) without allowing the pump motor to cool for thirty minutes. Continuous operation of the pump motor without allowing the motor to cool can damage the pump motor.**

Contact HWH corporation to get specific information about the system in this vehicle.

## COLD WEATHER OPERATIONS

HWH leveling and room extension systems are designed to function in cold weather down to 0 degrees Fahrenheit. Below freezing (32 degrees Fahrenheit) the jacks or rooms will operate slower than usual.

For operation in temperatures dropping below -20 degrees Fahrenheit, it is necessary that the system is equipped with oil designed for extreme cold weather application such as a synthetic oil. (Contact HWH for recommendations.)

**DO NOT run the pump motor continuously. It is important that any time the pump runs for more than three minutes with a 3" motor; or six minutes with a 3.7" or 4.5" motor that the motor is allowed to cool for thirty minutes before continuing. Continuous operation of the pump motor without allowing the motor to cool can damage the motor.** Continuous operation of the pump with slow moving jacks or rooms in cold weather, without allowing the pump motor to cool will cause the pump motor to burn up and damage the pump assembly.

---

# OPERATING PROCEDURES

---

## GENERAL INSTRUCTIONS

Maintain adequate clearance in all directions for vehicle, room extensions, awnings, doors, steps, etc. Vehicle may move in any direction due to jacks extending or retracting, settling of the jacks or the vehicle, equipment malfunction, etc..

**NOTE: This manual is intended for vehicles with a spring or air suspension. If the vehicle has an air suspension with a manual pilot air dump, refer to the vehicle manufacturer for operating instructions.**

If parking on soft ground or asphalt paving, a wood block or pad should be placed under each jack.

Press the "CANCEL" button or turn the ignition switch "OFF" at any time to stop the operation of the system.

Any time a hydraulic leveling process is interrupted, retract the jacks according to the JACK RETRACTION Section and then restart the leveling process.

If the hand / auto brake is not set when the "AUTO LEVEL" button is pressed, the "NOT IN PARK/BRAKE" light will come on. When the "AUTO LEVEL" button is released the "NOT IN PARK/BRAKE" light will go out. The Automatic Leveling function will not start.

**WARNING: DO NOT MOVE THE VEHICLE IF ONE OR MORE JACKS ARE EXTENDED TO THE GROUND.**

## PREPARATION FOR TRAVEL

**IMPORTANT: Before traveling, the red jack warning lights must be off the "TRAVEL MODE" light must be on and the vehicle should be at the proper height for travel. If lights are not correct for travel, retract jack as described in the JACK RETRACTION Section.**

If the jacks are retracted but a red "WARNING" light is lit the system needs to be serviced.

Any room extension or generator slide should be fully retracted before traveling.

**WARNING: DO NOT MOVE THE VEHICLE WHILE THE LEVELING JACKS ARE STILL IN CONTACT WITH THE GROUND OR IN THE EXTEND POSITION. THIS VEHICLE IS EQUIPPED WITH STRAIGHT-ACTING JACKS. MOVING THE VEHICLE WITH THE LEVELING JACKS EXTENDED CAN CAUSE SEVERE DAMAGE TO THE JACKS AND OR THE VEHICLE AND CREATE A DRIVING**

**HAZARD. DO NOT RELY SOLELY UPON WARNING LIGHTS. IT IS THE OPERATOR'S RESPONSIBILITY TO CHECK THAT ALL JACKS ARE FULLY RETRACTED INTO THE STORE/TRAVEL POSITION AND THE VEHICLE IS AT THE PROPER RIDE HEIGHT FOR TRAVELING. CONTACT MANUFACTURER TECHNICAL SERVICE BEFORE MOVING A VEHICLE THAT IS NOT AT PROPER TRAVEL HEIGHT.**

If the jacks cannot be retracted according to the JACK RETRACTION Section, retract the jacks according to the MANUAL JACK RETRACTION Section. The system should then be checked.

**NOTE: If the vehicle is parked or stored with the jacks extended for an extended period of time and the jacks fail to retract completely, extend the jacks back down to the ground then retract the jacks again.**

## HWH LIGHTED RESET SWITCH

The HWH lighted reset switch is located on the vehicle dash. If there is a failure at any time in the HWH CAN network, the network will shut down. The leveling system will not operate. If the ignition is off, no indicator lights will come on. If the ignition is in the "ON" or "ACC" position, the lighted reset switch and the MASTER WARNING Light will come on.

If the lighted reset switch is on, the switch must be pushed before the leveling system can be operated.

If the lighted reset switch will not go out when pushed, there is a problem with the central control module of the network system. The Leveling System will not operate.

## ROOM EXTENSION PROCEDURES

**IMPORTANT: If the vehicle is equipped with a room extension read this section carefully.**

It is recommended to complete the Leveling Procedure before operating room extensions. It is recommended to retract room extensions before retracting jacks.

Refer to the vehicle owners manual for proper operation of room extensions.

**IMPORTANT: Do not use a room extension support when the vehicle is supported by the leveling system.**

---

# OPERATING PROCEDURES

## 2000 SERIES LEVELING SYSTEM

---

### AUTOMATIC HYDRAULIC LEVELING

1. Place transmission in the recommended position for parking the vehicle and set parking brake. Turn the coach engine off. Turn the ignition to the "ACCESSORY" position.
2. At this time, the operator may want to check the jacks and place a pad under each jack if the ground will not support the vehicle.

**WARNING:** PRIOR TO PUSHING THE "AUTO LEVEL" BUTTON THE OPERATOR MUST BE SURE THAT ALL PERSONS AND OBJECTS ARE CLEAR OF THE VEHICLE. THE VEHICLE SUSPENSION WILL START TO DUMP AIR AND LOWER AS SOON AS THE AUTO LEVEL BUTTON IS PUSHED.

3. Press the "AUTO LEVEL" button one time. The AUTO LEVEL light will start to flash. Air will begin to dump air from the vehicle suspension. After approximately 25 seconds, the leveling process will begin.

**IMPORTANT:** During the Automatic Leveling procedures, pushing the "AUTO LEVEL", "AUTO STORE" or the "CANCEL" button on the HWH touch panel will stop the automatic leveling function.

**AUTO LEVEL SEQUENCE:** During the automatic leveling sequence, after the system has extended the appropriate jacks to level the vehicle and has turned the yellow level indicator lights off, the system will then stabilize the vehicle. While the system is stabilizing the vehicle, the yellow level indicator lights are inhibited from coming on. Stabilizing the vehicle is accomplished by extending any jacks to the ground that were not used to level the vehicle. This is done by monitoring a pressure switch on each jack. Any jack used to stabilize the vehicle will lift the vehicle approximately one half (½) inch. This "bumps" the vehicle up slightly when stabilizing. Due to the ½ degree accuracy tolerance of the sensing unit, one or two yellow level indicator lights may come on after the red auto level indicator light turns off. The slight lift experienced during the stabilizing procedure normally is not sufficient to cause a level issue for the motor home. However, a feature of the single step leveling system is the manual leveling buttons will function anytime the ignition is in the ON or ACC. position and the park brake is set. If desired, the operator can use the UP ARROWS (extend jacks) that correspond to any lit yellow level indicator light to "bump" the vehicle up slightly to turn that yellow indicator light off.

**EXCESS SLOPE SITUATION:** In the event the jacks are unable to level the coach, the "EXCESS SLOPE" light will come on. Excess slope is when two jacks are fully extended without turning the yellow level light out. The system will not stabilize the vehicle if the "EXCESS SLOPE" light comes on. One or more jacks may not be extended. The system will shut off leaving the "EXCESS SLOPE" light on. The "EXCESS SLOPE" light will remain on if there is power to the control box, until the jacks have been fully retracted using the "STORE" button, turning the red warning lights out. Move the vehicle to a more level position or level the vehicle as close as possible according to the MANUAL LEVELING section. Manual leveling will operate when the EXCESS light is on.

5. Turn the ignition switch to the "OFF" position.

---

# OPERATING PROCEDURES

## 725 / 2000 SERIES LEVELING SYSTEM

---

### JACK RETRACTION

**WARNING:** THE OPERATOR MUST BE SURE THAT THERE ARE NO OBJECTS UNDER THE VEHICLE AND THAT ALL PEOPLE ARE CLEAR OF THE VEHICLE.

1. Start the engine. Store the jacks immediately.
2. Press the "STORE" button. The store indicator light will flash. The vehicle should start to return to ride height. As each jack retracts, its red WARNING light will go out. The pump will run with all retract loads staying on until 10 seconds after the last red warning light goes out. If any warning light remains on the pump and all retract loads will remain on for (6) six minutes from the time the "AUTO STORE" button was pushed.

**IMPORTANT: DO NOT interrupt power to the leveling system while the "STORE" indicator light is blinking. DO NOT push the "OFF" button or turn the ignition key. The system must be allowed to completely finish the STORE mode.**

**WARNING:** DO NOT MOVE THE VEHICLE WHILE THE LEVELING JACKS ARE STILL IN CONTACT WITH THE GROUND OR IN THE EXTEND POSITION. THIS VEHICLE IS EQUIPPED WITH STRAIGHT-ACTING JACKS. MOVING THE VEHICLE WITH THE LEVELING JACKS EXTENDED CAN CAUSE SEVERE DAMAGE TO THE JACKS AND OR THE VEHICLE AND CREATE A DRIVING HAZARD. DO NOT RELY SOLELY UPON WARNING LIGHTS. IT IS THE OPERATOR'S RESPONSIBILITY TO CHECK THAT ALL JACKS ARE FULLY RETRACTED INTO THE STORE/TRAVEL POSITION AND THE VEHICLE IS AT THE PROPER RIDE HEIGHT.

3. The vehicle can be moved as soon as the red warning lights are out, the jacks are in the STORE/TRAVEL position, the green "TRAVEL" light is on, and the suspension air bags are inflated to the vehicles proper ride height.

**IMPORTANT: If a red warning light and buzzer come on while traveling, the jacks should be checked as soon as a safe parking location is found.**

4. If jacks cannot be retracted by the above procedure see MANUAL JACK RETRACTION Section.



---

# OPERATING PROCEDURES

---

## MANUAL HYDRAULIC OPERATION

1. Place transmission in the recommended position for parking the vehicle, and set the parking brake. Turn the ignition to the "ACCESSORY" position.

2. The air must be dumped from the vehicle suspension before leveling. Push and hold the "DUMP" button. Hold the "DUMP" button until all air is exhausted from the vehicle suspension.

3. Place pads under the jack feet if the ground will not support the vehicle on the jacks.

4. The vehicle may be leveled using the manual EXTEND (UP ARROW) buttons on the right half of the panel. If a yellow LEVEL SENSING light is on, that side or end of the vehicle is low. It is best to level the vehicle side to side first, if needed, before front to rear.

Jacks will extend (or retract) in pairs to raise (or lower) a side or end of the vehicle. Any jack not used for leveling can be extended to the ground. This provides additional stability against wind and activity in the vehicle. Jacks used to stabilize the vehicle after leveling is complete should lift the vehicle slightly after touching the ground.

**IMPORTANT: Do not continue to push an EXTEND button for more than ten (10) seconds after that pair of jacks are fully extended.**

5. When leveling is completed, turn the ignition switch to the "OFF" position.

**IMPORTANT: Push the "STORE" button before traveling when manual operation of the leveling system is used.**

---

# OPERATING PROCEDURES

---

## ROOM EXTEND PROCEDURE

**WARNING:** OPERATING A ROOM WITH ANY ROOM LOCKING, CLAMPING OR MANUAL RETRACTING DEVICES ATTACHED OR ENGAGED CAN CAUSE PERSONAL INJURY AND VEHICLE DAMAGE. IT IS THE OPERATOR'S RESPONSIBILITY TO ENSURE THAT ALL ROOM LOCKING, CLAMPING OR MANUAL RETRACTING DEVICES ARE DETACHED OR DISENGAGED BEFORE OPERATING THE ROOM.

Refer to vehicle manufacturer for proper sequence of room extension and leveling system operation.

1. Unlock all room-locking devices to include travel clamps/locks supplied by manufacturers other than HWH.

**NOTE:** If a **MANUAL RETRACT WINCH** is attached to the room remove it before extending the room.

**WARNING:** KEEP PEOPLE AND OBSTRUCTIONS CLEAR OF ROOM WHEN OPERATING.

**NOTE:** Make sure there is adequate clearance to fully extend the room.

2. Turn the room control panel KEY SWITCH to the "ON" position.

**NOTE:** The park brake must be set to operate the rooms.

3. To extend the room, press and hold the ROOM CONTROL SWITCH in the "EXTEND" position until the room is fully extended.

**IMPORTANT:** If the room extension is a level out room, hold the room control switch to the extend position until the room is fully extended and has dropped to the completely lowered position.

**NOTE:** Hold the switch to "EXTEND" three or four seconds after the room is fully extended. This assures proper pressurization of the cylinders. **During normal operation of the room, do not reverse direction of the room until the room is fully extended. If necessary, the direction of the room may be reversed, but watch for binding of the room. If the direction of the room has been reversed, DO NOT re-extend the room until the room has been fully retracted.**

**IMPORTANT:** Do not hold the ROOM CONTROL SWITCH in the "EXTEND" position for more than ten seconds after the room is fully extended (and down if applicable) or stops moving. **If either side of the room stops moving, release the room control switch immediately. DO NOT force the room. DO NOT reverse direction of the room, contact HWH Customer Service for assistance 1-800-321-3494.**

**NOTE:** Releasing the ROOM CONTROL SWITCH will halt the operation of the room.

4. Turn the room control panel KEY SWITCH to the "OFF" position.

**IMPORTANT:** Do not use a room extension support when the vehicle is supported by the leveling system.

---

# OPERATING PROCEDURES

---

## ROOM RETRACT PROCEDURE

**WARNING: KEEP PEOPLE AND OBSTRUCTIONS CLEAR OF ROOM WHEN OPERATING.**

Refer to vehicle manufacturer for proper sequence of room extension and leveling system operation.

1. The park brake must be set. The room will not operate if the park brake is not set.
2. Turn the room control panel KEY SWITCH to the "ON" position.
3. To retract the room press and hold the ROOM CONTROL SWITCH in the "RETRACT" position until the room is fully retracted.

**Important: if the room extension is a level-out room, the room must raise completely before it will retract. If the room will not raise, do not force the room. Refer to the MANUAL ROOM LIFT PROCEDURES page.**

**NOTE:** Hold the switch to "RETRACT" three or four seconds after the room is fully retracted. This assures proper pressurization of the cylinders. **During normal operation of the room, do not reverse direction of the room until the room is fully retracted. If necessary, the direction of the room may be reversed, but watch for binding of the room. If the direction of the room has been reversed, DO NOT retract the room until the room has been fully extended.**

**IMPORTANT:** Do not hold the ROOM CONTROL SWITCH in the "RETRACT" position for more than ten seconds after the room is fully retracted or stops moving. **If either side of the room stops moving, release the room control switch immediately. DO NOT force the room. DO NOT reverse direction of the room, contact HWH Customer Service for assistance 1-800-321-3494.**

**NOTE: Releasing the ROOM CONTROL SWITCH will halt the operation of the room.**

4. Turn the room control panel KEY SWITCH to the "OFF" position.
5. If the room will not retract see the MANUAL ROOM RETRACT PROCEDURE.

**IMPORTANT: Room-locking devices should be locked while traveling.**

# MANUAL ROOM AND GENERATOR SLIDE RETRACT PROCEDURE

(USE ONLY WHEN THE ROOM WILL NOT RETRACT WITH THE ROOM CONTROL SWITCH)

## OVERVIEW

The room can be retracted manually if a hydraulic or electric failure prevents the room from being retracted using the CONTROL SWITCH. For normal retract sequence see the ROOM SLIDE RETRACT PROCEDURES. Refer to the vehicle manufacturer for storage location of the retract device and information for connecting the device to the room.

**IMPORTANT:** If the vehicle is not equipped with a winch, DO NOT use other pulling devices to retract the room. Follow steps 2 and 3 and try pushing the room in. Contact the vehicle manufacturer or HWH Customer Service at 1-800-321-3494 or 563-724-3396 for assistance.

**WARNING:** A MANUAL RETRACT WINCH PROVIDED BY HWH IS EQUIPPED FOR MANUALLY RETRACTING THE ROOM ONLY. IT IS NOT TO BE USED FOR LIFTING OR ANY OTHER APPLICATION. HIGH FORCES ARE CREATED WHEN USING A WINCH, CREATING POTENTIAL SAFETY HAZARDS. FAILURE TO FOLLOW ALL WARNINGS AND INSTRUCTIONS MAY CAUSE FAILURE OF THE MANUAL RETRACT WINCH OR CONNECTIONS RESULTING IN DAMAGE OR PERSONAL INJURY. MAINTAIN A FIRM GRIP ON THE WINCH HANDLE AT ALL TIMES. NEVER RELEASE THE HANDLE WHEN RATCHET LEVER IS IN THE OFF POSITION AND THE WINCH IS LOADED. THE WINCH HANDLE COULD SPIN VIOLENTLY AND CAUSE PERSONAL INJURY. CHECK THE WINCH AND STRAPS FOR DAMAGE OR WEAR, AND CHECK FOR PROPER RATCHET OPERATION ON EACH USE OF THE WINCH. DO NOT USE IF DAMAGED OR WORN.

1. Retract jacks following the LEVELING SYSTEM RETRACT PROCEDURE.

**NOTE :** When manually retracting the room, it is recommended the jacks are retracted before retracting the room.

2. Locate the HYDRAULIC PUMP and/or MANIFOLD unit. Some systems may have a remote manifold.

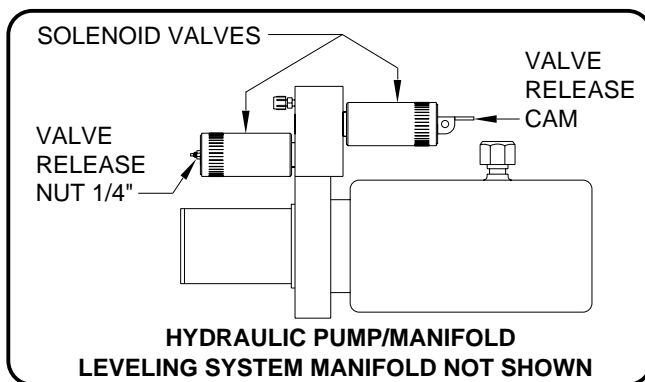

3. Open Nut Style Solenoid Valves by slowly turning the valve release nut counter clockwise using a 1/4" nut driver.

**IMPORTANT:** Only open the valves enough to retract the room. DO NOT turn the release nuts more than 4 and 1/2 turns. Turning the nuts more could damage the valves.

Open Cam Style Solenoid Valves by following the instructions located on the last page of this manual MP84.9999.

**NOTE:** The room may move slightly as the SOLENOID VALVES are opened and internal pressure is released.

4. Locate the MANUAL RETRACT DEVICE and connect it to the room according to the vehicle manufacturer's instructions. To extend a WINCH STRAP firmly grasp WINCH HANDLE, place RATCHET LEVER in its OFF position, and slowly rotate the WINCH HANDLE counter clockwise, keeping a firm grip on the handle. When enough WINCH STRAP is extended, place the RATCHET LEVER in its ON position and slowly rotate the WINCH HANDLE clockwise until the RATCHET LEVER locks.

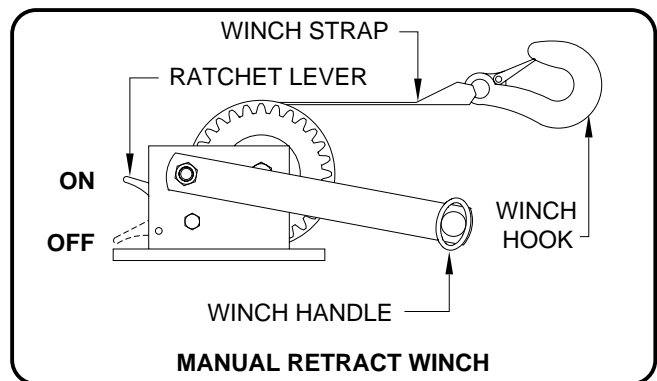

5. Slowly winch the room in by turning the WINCH HANDLE clockwise. The RATCHET LEVER should produce a loud, sharp, clicking noise.

**NOTE:** Winching the room in quickly will raise pressure in the hydraulic fluid and make winching more difficult.

**WARNING:** OPERATE THE MANUAL RETRACT WINCH BY HAND POWER ONLY. IF THE WINCH CANNOT BE CRANKED EASILY WITH ONE HAND IT IS PROBABLY OVERLOADED. IF WINCHING BECOMES TO DIFFICULT STOP AND CHECK FOR OBSTRUCTIONS/RESTRICTIONS ON THE ROOM AND ROOM EXTENSION MECHANISM.

6. When the room is fully retracted, engage the room locking devices. Leave the retract winch engaged and the solenoid valves open.

**WARNING:** THE ROOM EXTENSION SOLENOID VALVE RELEASE MUST BE IN THE OPEN POSITION WHEN THE MANUAL RETRACT WINCH IS ENGAGED.

7. The system should be repaired before using again.

**NOTE:** After repairs are made, when closing the VALVE RELEASE NUTS, do not over tighten the nuts.

# OPERATING PROCEDURES

## AUXILIARY PUMP RUN SWITCH OPERATION

**WARNING:** KEEP AWAY FROM WHEELS, DO NOT CRAWL UNDER THE VEHICLE, KEEP A SAFE DISTANCE IN FRONT AND REAR OF THE VEHICLE. THE VEHICLE MAY DROP AND / OR MOVE FORWARD OR BACKWARD WITHOUT WARNING AS THE VALVE RELEASE IS OPERATED.

### EXTEND JACKS OR ROOMS

**NOTE:** It is best if jacks are extended in pairs; both front, both rear, right front & right rear or left front & left rear. Only try to extend one room or step mechanism at a time.

1. Use the hydraulic connection diagrams to locate the appropriate valve(s) to extend the desired jack(s), room or step.
2. Locate the pump run switch on the power unit assembly.
3. Move the valve release cam(s) to the "VALVE OPEN" position.
4. Push the pump run toggle switch to the "RUN" position. Hold the toggle switch to "RUN" until the equipment is in the desired position.
5. Move the valve release cam(s) to the "VALVE CLOSED" position and release the the pump run toggle switch.

**NOTE:** If the pump toggle switch is released before closing a valve when extending a jack, the vehicle will drop until the valve is closed.

**IMPORTANT:** RELEASE CAM MIGHT BE ROTATED TO ANY DIRECTION ON THE VALVE. MAKE SURE TO MOVE THE RELEASE CAMS IN THE CORRECT DIRECTION. INCORRECT MOVEMENT OF THE CAMS CAN DAMAGE THE VALVES.

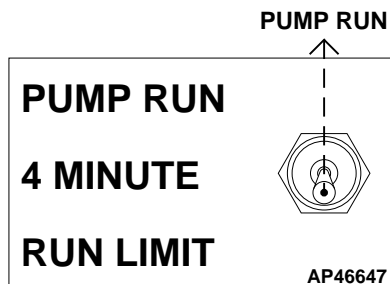

**IMPORTANT:** DO NOT hold the pump toggle switch to "PUMP RUN" for more than 4 minutes without allowing the pump motor to cool.

### RETRACTING POWER - EXTEND / POWER - RETRACT JACKS ROOMS OR STEPS

**IMPORTANT:** POWER - EXTEND / SPRING - RETRACT JACKS (SINGLE ACTING CYLINDERS) CAN NOT BE RETRACTED WHEN THE PUMP IS RUNNING.

**WARNING:** DO NOT CRAWL UNDER THE VEHICLE TO OPEN JACK MANIFOLD VALVES. ALLOW AMPLE ROOM FOR THE VEHICLE TO MOVE IN ANY DIRECTION WHEN A JACK MANIFOLD VALVE IS OPENED. OPEN THE VALVE RELEASE CAMS SLOWLY TO KEEP THE VEHICLE FROM DROPPING RAPIDLY.

1. Use the hydraulic connection diagrams to locate the appropriate valve(s) to retract the desired jack(s), room or step.
2. Locate the pump run switch on the power unit assembly.
3. Move the valve release cam(s) to the "VALVE OPEN" position.

**IMPORTANT:** WHEN RETRACTING JACKS, THE VEHICLE WILL START TO DROP AS SOON AS A JACK VALVE IS OPENED.

4. Push the pump run toggle switch to the "RUN" position. Hold the toggle switch to "RUN" until the equipment is fully retracted.
5. Move the valve release cam(s) to the "VALVE CLOSED" position and release the the pump run toggle switch.

**NOTE:** WHEN RETRACTING JACKS - Start with the front jacks. Alternate between the left and right jack several times, partially opening the jack valve slowly. This will allow the jacks to retract slightly each time, until the weight of the vehicle is off the jacks. This will reduce the possibility of twisting the vehicle. With the weight of the vehicle off the front jacks, open the front jack valves and use the pump run toggle switch. When both front jacks completely retracted, repeat the process with the rear jacks.

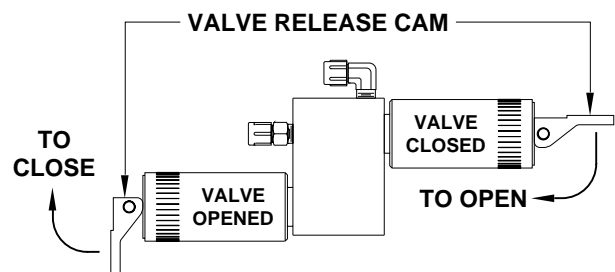

# OPERATING PROCEDURES

## AUXILIARY HAND PUMP OPERATION

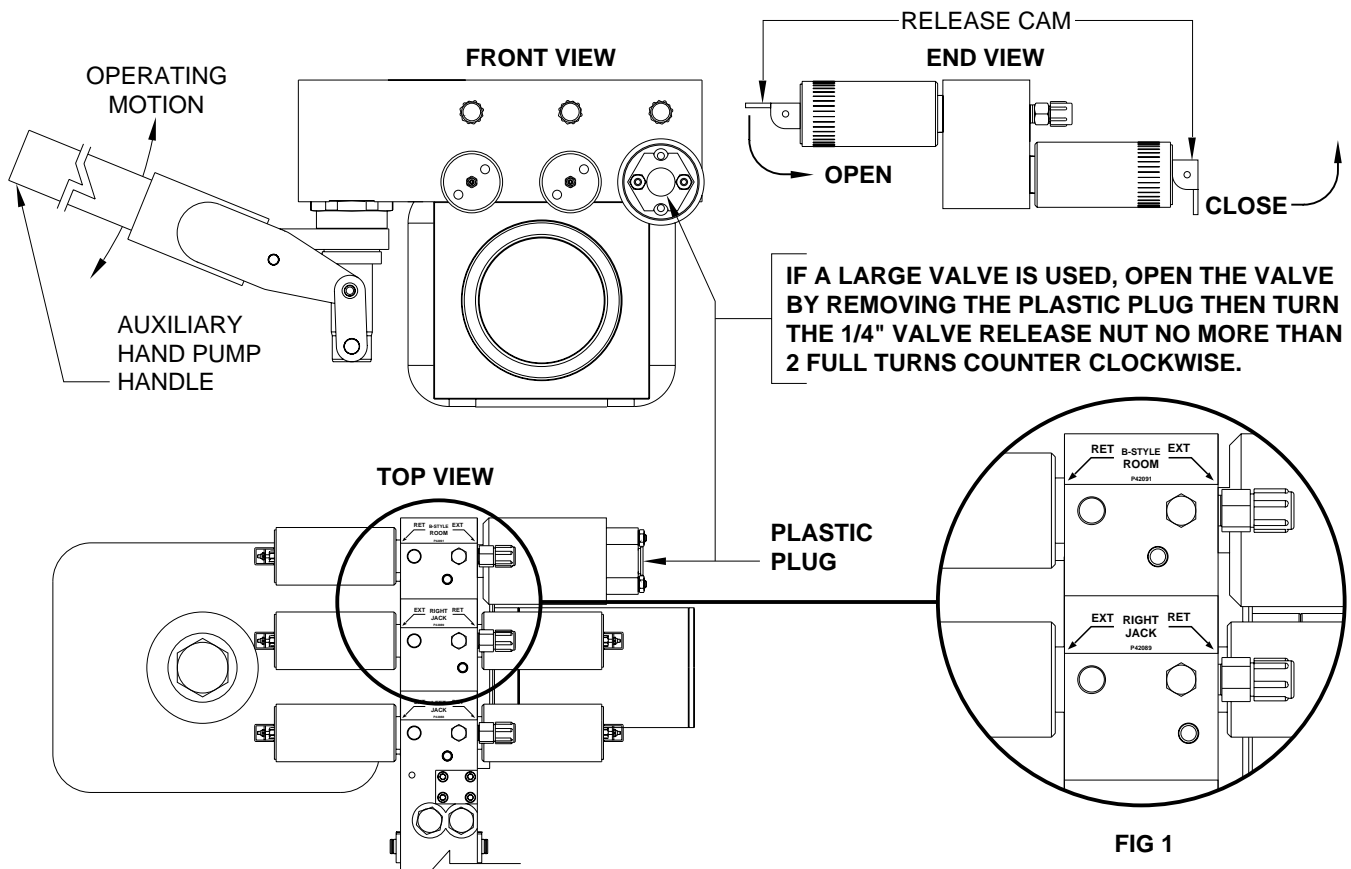

FIG 1

**NOTE:** Each hydraulic function requires a pair of solenoid valves one each for the extend and retract procedures. The number of functions and the items controlled by each pair of solenoid valves will vary for each system. The diagrams shown on this page represent a (3) function system of (2) jacks and (1) room as indicated by the labels shown in FIG 1. Use the labels specific to your system when following these procedures. Room control solenoid valves may be located at the synchronizing cylinder, not on the pump manifold.

The auxiliary hand pump can be used to extend or retract the landing gear, jacks or room extensions anytime the pump will not function.

The auxiliary hand pump is a two stage pump that will produce enough pressure to extend the landing gear and lift the vehicle as well as retract the landing gear. When operating the auxiliary pump to lift the vehicle or when the jacks are fully retracted, the pump handle will seem to "snap" as the pump goes to the second stage. The pumping action will be easier at first as the second stage starts to create more pressure.

**NOTE:** The hand pump will swivel to any position which will ease the operation of the hand pump.

To operate the auxiliary hand pump, open the appropriate solenoid valve. Insert the hand pump handle into the handle receptacle and move the handle in an up and down motion.

**NOTE:** If a room cannot be retracted using the auxiliary hand pump, see "MANUAL ROOM RETRACTION PROCEDURES".

**WARNING:** THE VEHICLE SHOULD BE SUPPORTED BY AUXILIARY STANDS OR SECURELY HITTED TO THE TOW VEHICLE BEFORE OPENING ANY VALVES.

The auxiliary hand pump may work easier if only one valve is open at a time. **Be careful to not twist the vehicle if only one solenoid valve is open.**

**IMPORTANT:** FOLLOW THE "SET UP" AND "PREPARATION FOR TRAVEL" PROCEDURES WHEN USING THE AUXILIARY HAND PUMP.

It is recommended to operate the auxiliary hand pump occasionally to check its operation.

**IMPORTANT:** ONLY MOVE THE RELEASE CAM IN THE DIRECTION SHOWN. MOVING THE CAM IN THE OPPOSITE DIRECTION CAN DAMAGE THE VALVES.

---

# MAINTENANCE

---

## OIL LEVEL

All maintenance should be done as part of the normal servicing of the coach.

The oil level should be checked when the vehicle is first purchased and then once every two years. More often if there is an oil leak in the system.

Any HWH hydraulic equipment, including jacks, slide-outs and steps should be fully retracted before checking fluid level. The oil reservoir is part of the pump / manifold assembly. The oil level is checked and filled through the breather cap. Clear any dirt away from the breather / filler cap before removing.

The oil level should be within one inch of the top of the reservoir. Most breather caps have a dipstick. Fluid level should be between the bottom of the dipstick and the center mark.

**NOTE: Overfilling the tank can cause leakage of oil through the breather cap.**

**FLUID:** HWH Specialty Hydraulic Oil is recommended. In an emergency Dexron automatic transmission fluid can be used. **NOTE:** Dexron automatic transmission fluid contains red dye and can cause staining should a leak occur. **DO NOT USE** brake fluid or hydraulic jack fluid. Use of these can damage seals.

## UNUSUAL CONDITIONS

In general, to insure the smooth operation of the leveling system, it is a good idea to occasionally check the individual leveling units to prevent problems. This is especially true under the unusual conditions stated in the following:

If driving conditions are unusually muddy, the units may become caked or clogged with mud. This condition may hamper the proper operation of the leveling system. This problem may be prevented or remedied by cleaning off each leveling unit if they become excessively muddy.

In wet or icy weather leveling units may become encrusted with ice. This may cause the leveling system to function improperly. To eliminate this problem, periodically check the leveling units and break loose any ice which may be causing improper operation.

Do not move the trailer while the leveling units are still in contact with the ground. Visually check to see if the leveling units have returned to the STORE/TRAVEL position before moving the trailer.

**NOTE:** All major components of the system can be replaced with rebuilt units or can be sent to HWH CORPORATION to be rebuilt, when the system is out of warranty.

## WINTER WEATHER DRIVING

Anti-icing / deicing agents when splashed on your vehicle, continue to absorb moisture from the air even after they have dried. This can facilitate corrosion of metallic components, such as HWH jacks.

To help reduce the corrosion of jacks after exposure to anti-icing / deicing agents, thoroughly wash jacks with warm soapy water.

# MAINTENANCE

## PRIMING THE HAND PUMP

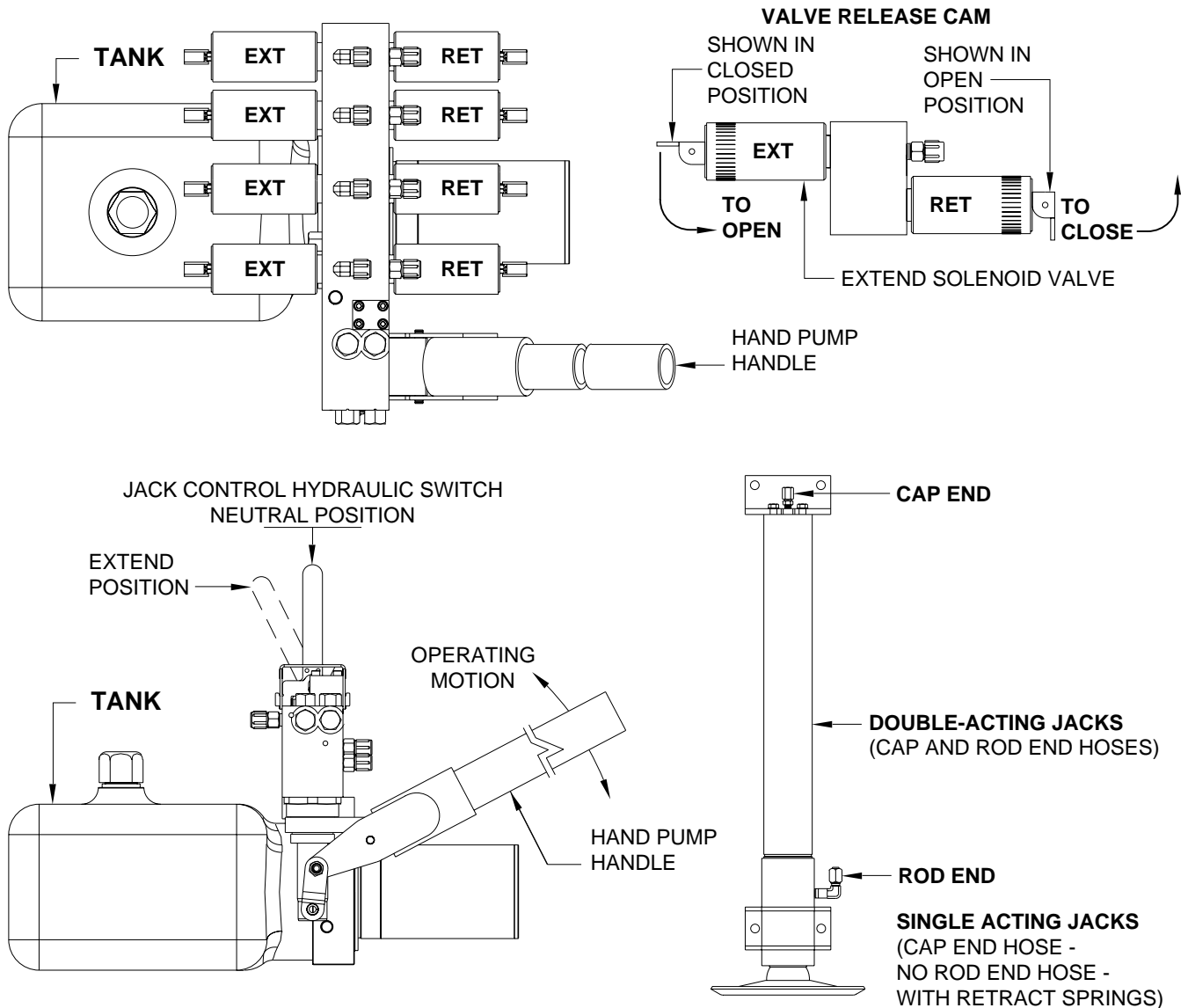

To prime the hand pump, it will be necessary to remove a hose from one of the jacks. One of the front jacks would be best, but use the easiest hose to get to.

If the system has Double-Acting cylinders on the front, remove the rod end hose from either of the front jacks. Place the end of the hose in a bucket. Make sure the tank is at least half full. Pump the hand pump until a healthy flow of oil is coming from the hose.

**IMPORTANT: DO NOT ALLOW THE FLUID LEVEL IN THE TANK TO LOWER MORE THAN 1 INCH BEFORE ADDING FLUID.**

Reattach the hose and retry the hand pump. Repeat the procedure if the hand pump does not move the jacks.

If the system has only Single-Acting jacks with return springs, remove the easiest hose to access and place the end in a bucket. Using the release cam, manually open the EXTEND solenoid valve for that jack (if equipped with solenoid valves) or move the jack control hydraulic switch to "EXTEND" for that jack. Make sure the tank is at least half full. Pump the hand pump until a healthy flow of fluid comes from the hose.

**IMPORTANT: DO NOT ALLOW THE FLUID LEVEL IN THE TANK TO LOWER MORE THAN 1 INCH BEFORE ADDING FLUID.**

Reattach the hose and retry the hand pump. Repeat the procedure if the hand pump does not move the jacks.



# SENSING UNIT MAINTENANCE/SERVICE

## SENSING UNIT ACCURACY TOLERANCE

The sensing unit has an accuracy tolerance of  $\pm 5.4$  inches front to rear and  $\pm 1$  inch side to side on a 36 foot vehicle. Typical leveling results will be better.

## SENSING UNIT ADJUSTMENT

Level the vehicle by placing a bubble level in the center of the freezer floor or upon whichever surface within the vehicle that is to be level. Using the Leveling System and the bubble level, ignoring the yellow LEVEL lights on the Touch Panel, level the vehicle until the bubble is centered.

With the vehicle level according to the bubble level, if there are no yellow lights lit on the Touch Panel, the sensing unit is properly adjusted. If there are yellow LEVEL lights lit on the Touch Panel, manual adjustments to the Sensing Unit are needed. A Phillips screw driver or sockets w/driver or box end wrenches of 7/8, 3/4, 1/2, 5/16 or 1/4 sizes will be needed.

The Sensing Unit is mounted inside the Control Box. The Control Box is mounted to the power unit/valve assembly.

There are four LED's on the Sensing Unit, A,B,C and D. Refer to the drawing below. The Sensing Unit is adjusted by turning the adjustment nut to turn out LED's B and D. The adjustment screw will turn out LED's A and C. If the adjustment nut has to be turned more than 1/2 flat or the adjustment screw has to be turned more than 3/4 turn to turn the LED out, there may be a problem with the Sensing Unit or the mounting of the Control Box. If two LED's are on, it is best to make the B-D adjustments first, then hold the adjustment nut from moving while making the A-C adjustment.

**NOTE: If opposing LED's are lit, there is a problem with the Sensing Unit.**

**If LED (A) is lit: Turn the adjustment screw COUNTER CLOCKWISE until the LED is off.**

**If LED (C) is lit: Turn the adjustment screw CLOCKWISE until the LED is off.**

**If LED (B) is lit: Turn the adjustment nut COUNTER CLOCKWISE until the LED is off.**

**If LED (D) is lit: Turn the adjustment nut CLOCKWISE until the LED is off.**

**IMPORTANT: When all 4 LED's are off, move the vehicle to an unlevel position so one or two yellow lights are on. Level the vehicle according to the yellow LEVEL lights. Recheck the level. If more adjustment is needed, DO NOT try to adjust the sensing unit until the yellow level lights go out, instead just "tweak" the sensing unit, ignoring the LED's on the sensing unit.**

**Example: After the initial adjustment and releveling the vehicle, the front is still low. This means the front yellow level light is turning off too soon. Determine which sensing unit light is the front light, A-B-C or D. Move the adjustment for that light very, very, slightly in the OPPOSITE direction that is given in the above instructions for LED's A, B, C, and D. This will allow the front yellow light to stay on slightly longer to bring the front up more. Again, unlevel the vehicle then relevel the vehicle using the yellow level lights on the touch panel. Recheck with a level. Repeat the "tweaking" process until the system levels the vehicle properly.**

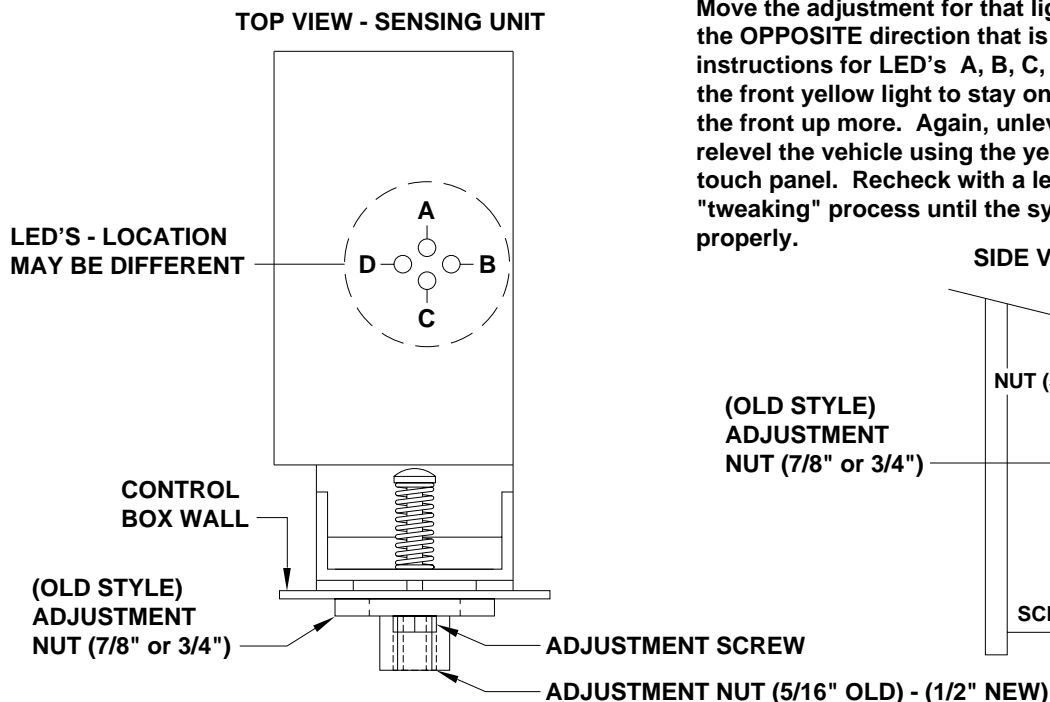

# HYDRAULIC LINE CONNECTION DIAGRAM

## 2000 SERIES LEVELING SYSTEM

### 4 - STRAIGHT-ACTING, POWER-EXTEND/POWER-RETRACT JACKS

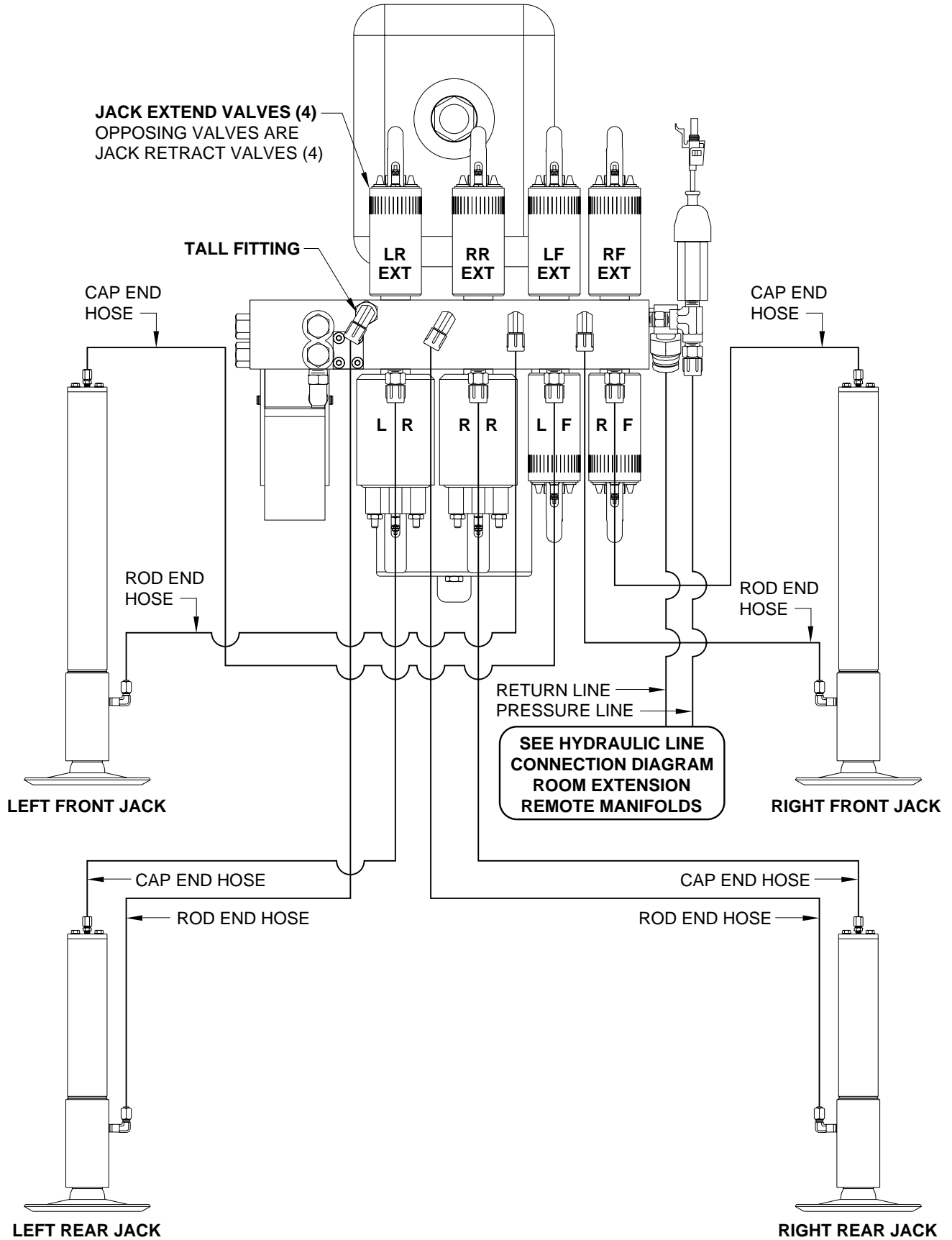

# HYDRAULIC LINE CONNECTION DIAGRAM

## REMOTE ROOM MANIFOLDS

ROOM 1  
**RETRACT ROOM TO  
 CHECK OIL LEVEL**

SEE HYDRAULIC LINE  
 CONNECTION DIAGRAMS  
 SINGLE CYLINDER  
 GUIDED SLIDE OUT

SEE HYDRAULIC LINE CONNECTION DIAGRAM  
 2000 SERIES LEVELING SYSTEM

**VALVE FUNCTION**

**1E - ROOM 1 CYLINDER EXTEND  
 ROOM EXTEND**

**1R - ROOM 1 CYLINDER RETRACT  
 ROOM RETRACT**

**2E - ROOM 2 CYLINDER EXTEND  
 ROOM EXTEND**

**2R - ROOM 2 CYLINDER RETRACT  
 ROOM RETRACT**

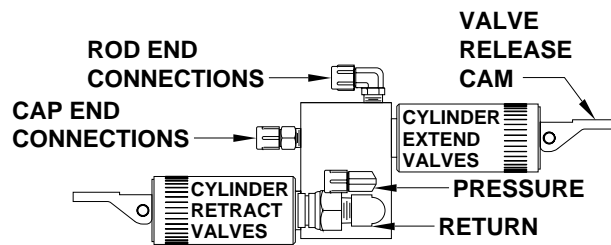
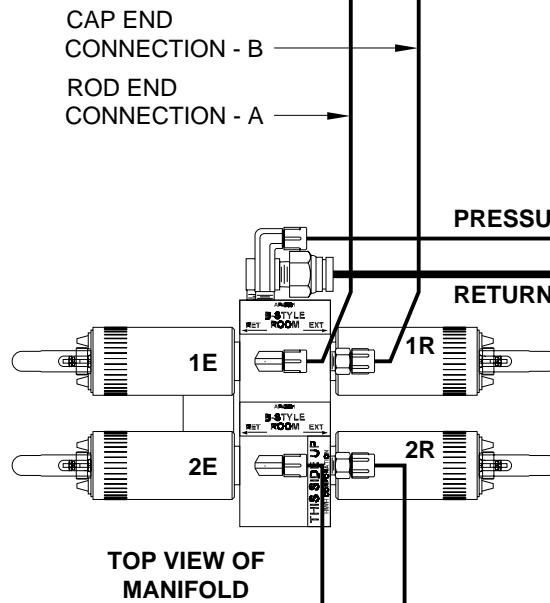

CAP END  
 CONNECTION - B  
 ROD END  
 CONNECTION - A

SEE HYDRAULIC LINE  
 CONNECTION DIAGRAMS  
 DUAL CYLINDER  
 IN-FLOOR SLIDE OUT

ROOM 2  
**RETRACT ROOM TO  
 CHECK OIL LEVEL**

---

# HYDRAULIC LINE CONNECTION DIAGRAM SINGLE CYLINDER "GUIDED" ROOM EXTENSION

---

**NOTE:** THE ROD END CONNECTION  
FROM THE MANIFOLD TO THE ROOM  
CYLINDER IS ALWAYS PRESSURIZED.

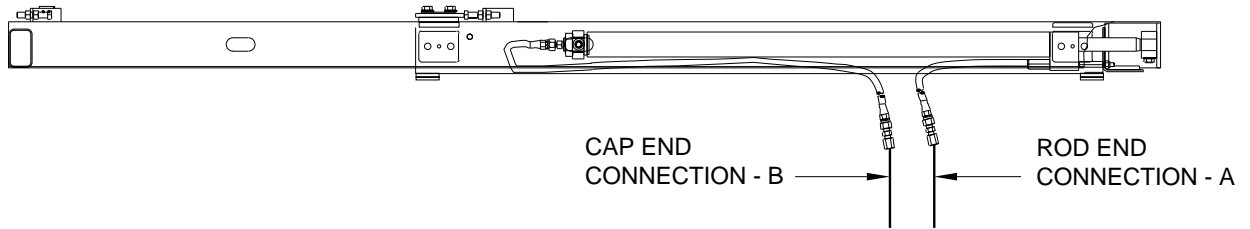

**CYLINDER EXTEND - ROOM EXTEND  
CYLINDER RETRACT - ROOM RETRACT  
CHECK OIL LEVEL WITH ROOM RETRACTED.**

**HYDRAULIC LINE CONNECTION DIAGRAM  
 DUAL CYLINDER "IN FLOOR" ROOM EXTENSION  
 (WITH SYNCHRONIZING CYLINDER)  
 SINGLE CYLINDER "IN FLOOR" ROOM EXTENSION**

**DUAL CYLINDER "IN FLOOR" ROOM EXTENSION  
 (WITH SYNCHRONIZING CYLINDER)**

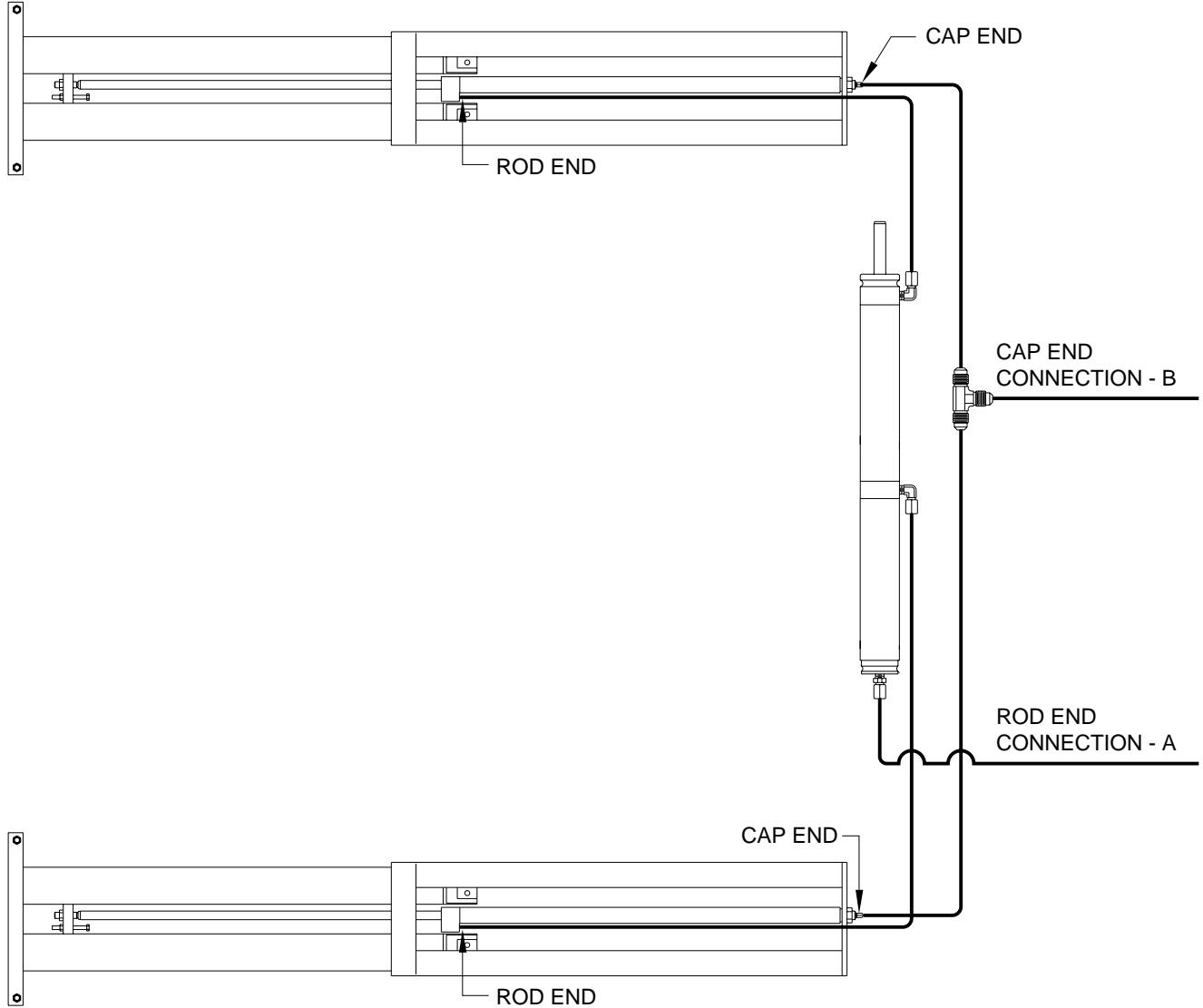

**CYLINDER EXTEND - ROOM EXTEND  
 CYLINDER RETRACT - ROOM RETRACT**

**SINGLE CYLINDER "IN FLOOR" ROOM EXTENSION**

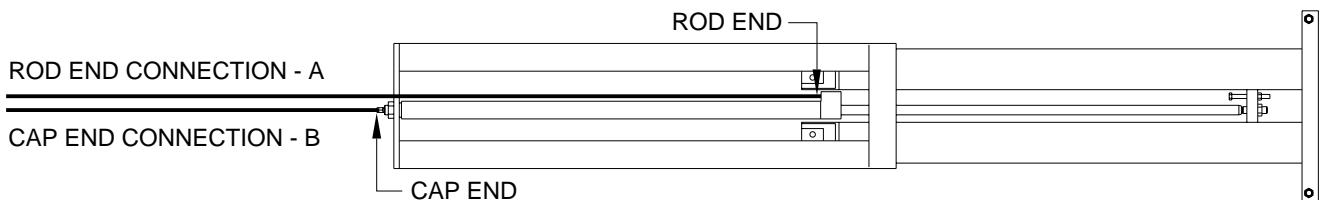

**CYLINDER EXTEND - ROOM EXTEND  
 CYLINDER RETRACT - ROOM RETRACT**

# ELECTRICAL CONNECTION DIAGRAM

## CENTRAL CONTROL MODULE

### HARNESS ROUTING - PAGE 1 OF 4

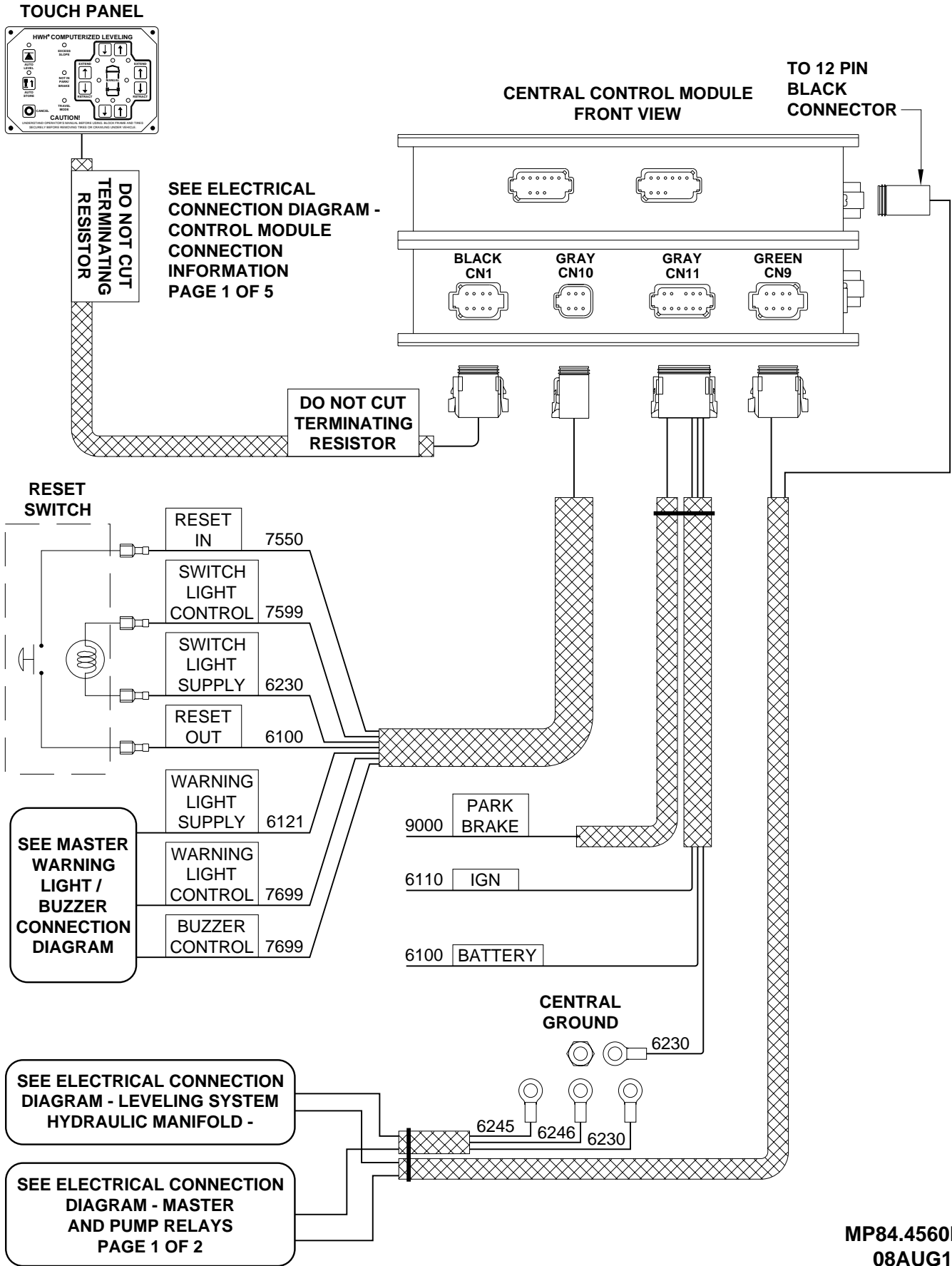

# ELECTRICAL CONNECTION DIAGRAM

## ROOM CONTROL PANEL CONNECTIONS

### HARNESS ROUTING - PAGE 2 OF 4

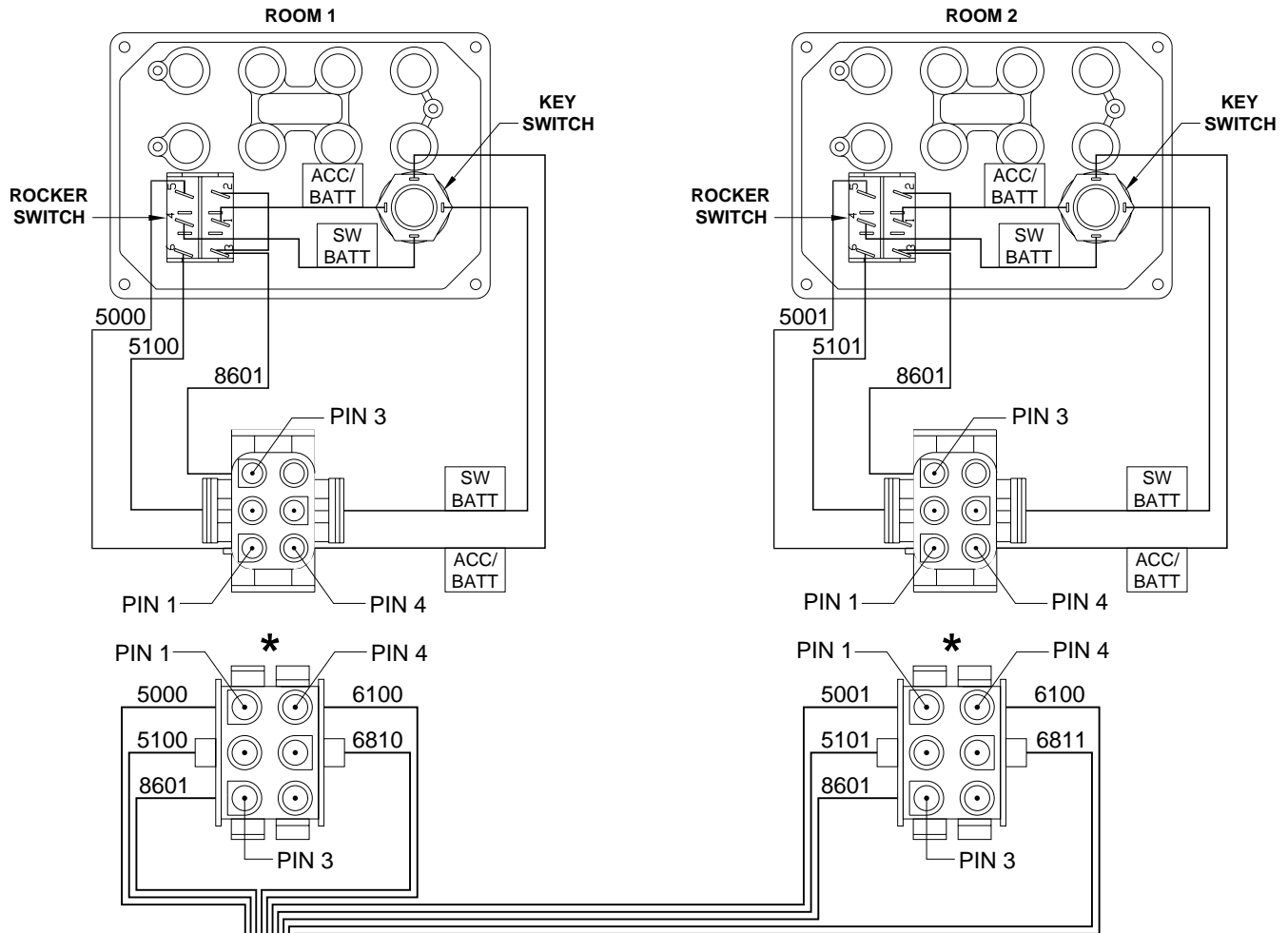

**\* ROOM CONTROL PANEL PIN AND WIRE INFORMATION**

- PIN 1 - 5000 (ROOM 1) 5001 (ROOM 2) - BLACK - SW+12 ROOM EXTEND
- PIN 2 - 5100 (ROOM 1) 5101 (ROOM 2) - BLACK - SW+12 ROOM RETRACT
- PIN 3 - 8601 - BLACK - SW+12 FOR PUMP CONTROL
- PIN 4 - 6100 - RED - +12 BATTERY
- PIN 5 - 6810 - (ROOM 1) 6811 (ROOM 2) - BLACK - SW+12 FROM PUMP RELAY
- PIN 6 - NO CONNECTION

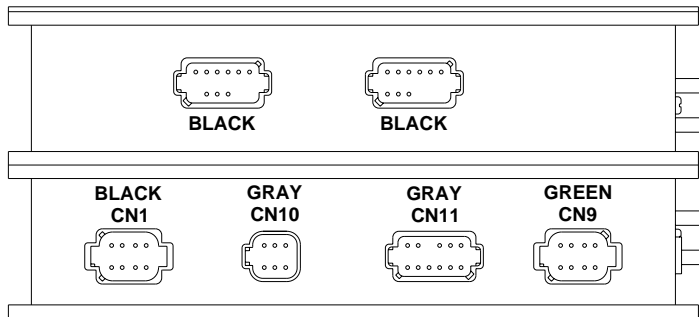
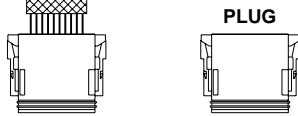

**NOTE: THE ROOM PANEL HARNESS IS SUPPLIED BY THE VEHICLE MANUFACTURER. WIRE COLORS AND/OR NUMBERS MAY DIFFER FROM WHAT IS SHOWN.**

**CENTRAL CONTROL MODULE - FRONT VIEW SEE ELECTRICAL CONNECTION DIAGRAM - CONTROL MODULE CONNECTION INFORMATION - PAGE 2 OF 5**

# ELECTRICAL CONNECTION DIAGRAM

## CENTRAL CONTROL MODULE

### HARNESS ROUTING - PAGE 3 OF 4

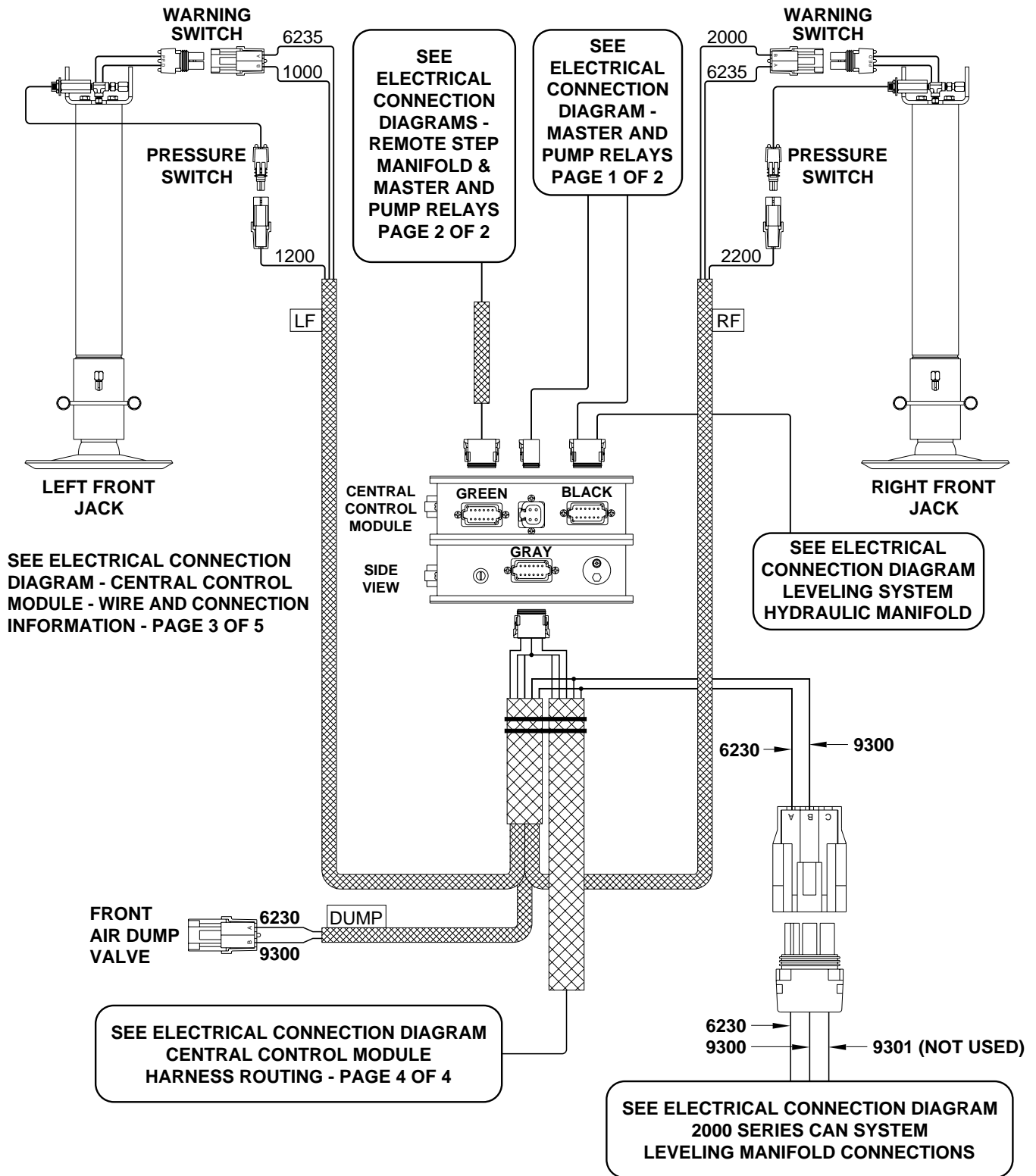



# ELECTRICAL CONNECTION DIAGRAM

## CENTRAL CONTROL MODULE

### HARNESS ROUTING - PAGE 4 OF 4

SEE ELECTRICAL CONNECTION  
DIAGRAM - CENTRAL CONTROL  
MODULE - WIRE AND CONNECTION  
INFORMATION - PAGE 3 OF 5

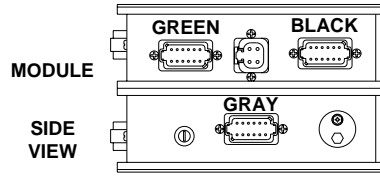

SEE ELECTRICAL CONNECTION DIAGRAM  
CENTRAL CONTROL MODULE  
HARNESS ROUTING - PAGE 3 OF 4

SEE ELECTRICAL CONNECTION DIAGRAM  
CENTRAL CONTROL MODULE  
HARNESS ROUTING - PAGE 3 OF 4

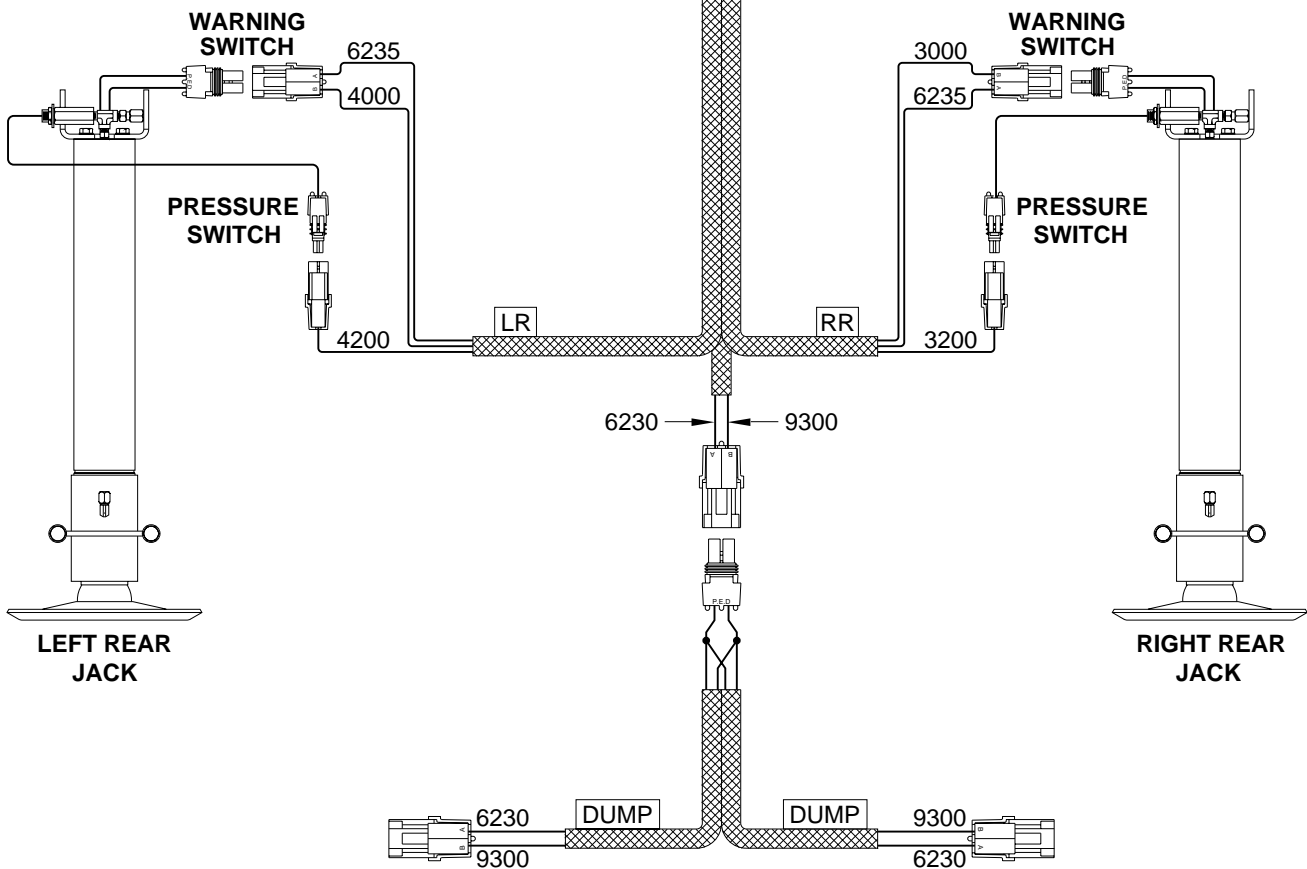

# ELECTRICAL CONNECTION DIAGRAM

## CENTRAL CONTROL MODULE

### WIRE AND CONNECTION INFORMATION - PAGE 1 OF 5

FRONT VIEW

TWO 12 PIN BLACK CONNECTORS ON TOP RING ARE NOT SHOWN

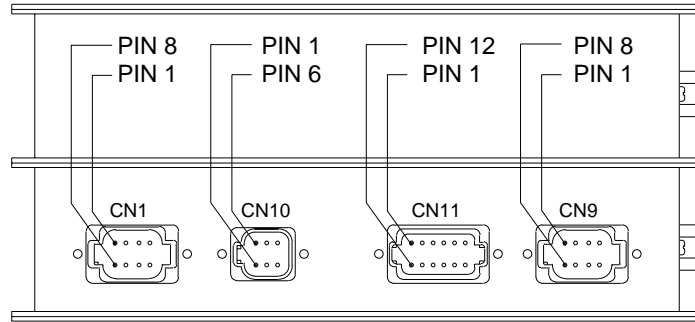

PIN #	WIRE COLOR	WIRE NUMBER	WIRE DESCRIPTION AND FUNCTION
<b>CN1</b>			<b>8 PIN BLACK CONNECTOR</b>
1 AND 2			NO CONNECTION
3	RED	6800	SWITCHED +12 TO TOUCH PANEL
4	WHITE	6230	GROUND
5			CAN SHIELD
6	RED	6110	IGNITION +12 - NOT USED
7	GREEN		CAN LOW
8	YELLOW		CAN HIGH
<b>CN10</b>			<b>6 PIN GRAY CONNECTOR</b>
1	BLACK	7599	RESET SWITCH LIGHT CONTROL-SWITCHED +12
2	RED	6100	RESET SWITCH SUPPLY +12
3	BLACK	7550	RESET SWITCH OUTPUT +12
4	RED	6121	WARNING LIGHT AND BUZZER SUPPLY +12
5	WHITE	6230	RESET SWITCH LIGHT GROUND
6	BLACK	7699	WARNING LIGHT AND BUZZER CONTROL - SWITCHED GROUND
<b>CN11</b>			<b>12 PIN GRAY CONNECTOR</b>
1	RED	6110	SWITCHED +12 FROM IGNITION
2 THRU 4			NO CONNECTION
5	RED	6110	SWITCHED +12 FROM IGNITION
6	RED	6100	BATTERY +12
7	WHITE	6230	GROUND FOR PROCESSOR
8 THRU 10			NO CONNECTION
11	BLACK	9000	FROM PARK BRAKE SWITCH - SWITCHED GROUND
12	RED	6100	BATTERY +12
<b>CN9</b>			<b>8 PIN GREEN CONNECTOR</b>
1	BLACK	8500	MASTER RELAY CONTROL SWITCHED +12
2	BLACK	8100	SWITCHED GROUND FROM 3000 LB PRESSURE SWITCH
3			NO CONNECTION
4	BLACK	8600	PUMP RELAY CONTROL SWITCHED +12
5			NO CONNECTION
6	BLACK	9901	PUMP MONITOR - SWITCHED +12 FROM PUMP RELAY
7 AND 8			NO CONNECTION

**ELECTRICAL CONNECTION DIAGRAM**  
**CENTRAL CONTROL MODULE**  
**WIRE AND CONNECTION INFORMATION - PAGE 2 OF 5**

FRONT VIEW

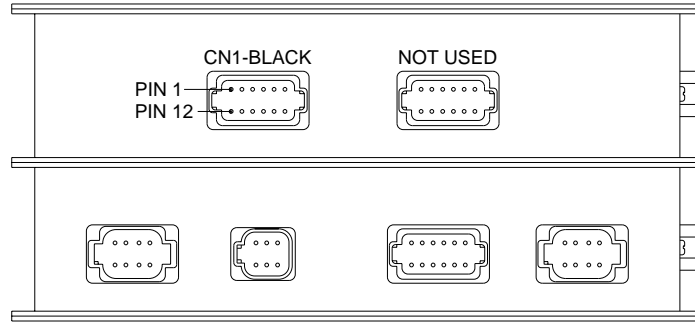

PIN #	WIRE COLOR	WIRE NUMBER	WIRE DESCRIPTION AND FUNCTION
<b>CN1</b>			<b>12 PIN BLACK CONNECTOR</b>
1	BLACK	6810	SWITCHED +12 FROM PUMP RELAY TO ROOM 1 CONTROL
2	BLACK	5000	SWITCHED +12 TO CONTROL BOX ROOM 1 EXTEND
3	BLACK	5100	SWITCHED +12 TO CONTROL BOX ROOM 1 RETRACT
4	BLACK	6811	SWITCHED +12 FROM PUMP RELAY TO ROOM 2 CONTROL
5	BLACK	5001	SWITCHED +12 TO CONTROL BOX ROOM 2 EXTEND
6	BLACK	5101	SWITCHED +12 TO CONTROL BOX ROOM 2 RETRACT
7			NO CONNECTION
8			KEYING PIN
9			NO CONNECTION
10	BLACK	8601	SWITCHED +12 TO CONTROL BOX - PUMP CONTROL
11	RED	6100	+12 BATTERY
12			KEYING PIN

# ELECTRICAL CONNECTION DIAGRAM

## CENTRAL CONTROL MODULE

### WIRE AND CONNECTION INFORMATION - PAGE 3 OF 5

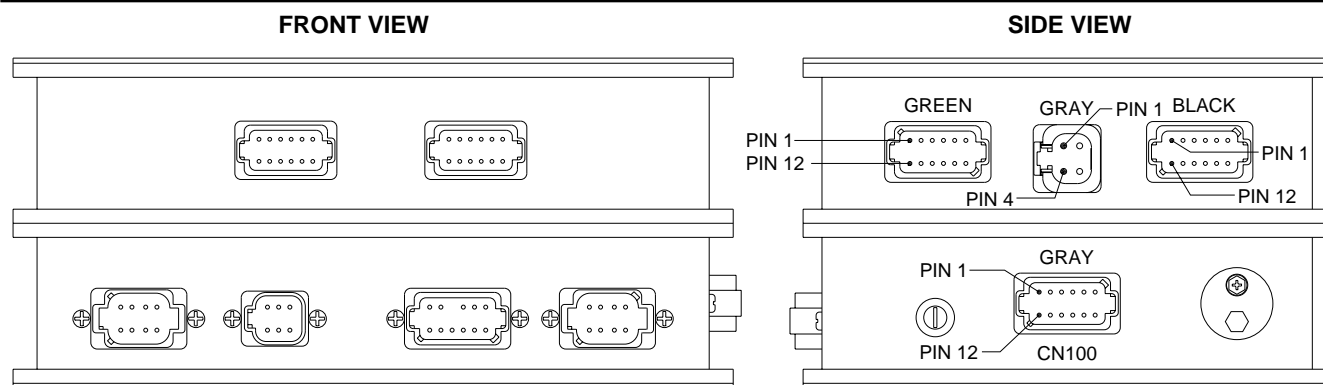

PIN #	WIRE COLOR	WIRE NUMBER	WIRE DESCRIPTION AND FUNCTION
<b>GREEN CONNECTOR</b>			<b>12 PIN GREEN CONNECTOR</b>
1	BLACK	5050	SWITCHED +12 FOR ROOM 1 CYLINDER EXTEND SOLENOID VALVE
2	BLACK	5150	SWITCHED +12 FOR ROOM 1 CYLINDER RETRACT SOLENOID VALVE
3	BLACK	5051	SWITCHED +12 FOR ROOM 2 CYLINDER EXTEND SOLENOID VALVE
4	BLACK	5151	SWITCHED +12 FOR ROOM 2 CYLINDER RETRACT SOLENOID VALVE
5 THRU 10			NO CONNECTION
11	BLACK	6810	SWITCHED +12 BATTERY FROM PUMP RELAY
12	BLACK	6810	SWITCHED +12 BATTERY FROM PUMP RELAY
<b>GRAY</b>			<b>4 PIN GRAY CONNECTOR</b>
1	BLACK	6800	SWITCHED +12 FROM MASTER RELAY
2	BLACK	6800	SWITCHED +12 FROM MASTER RELAY
3	WHITE	6230	GROUND FROM GROUND STUD
4	WHITE	6230	GROUND FROM GROUND STUD
<b>BLACK</b>			<b>12 PIN BLACK CONNECTOR</b>
1	BLACK	1400	SWITCHED +12 FOR LEFT FRONT EXTEND SOLENOID VALVE
2	BLACK	1500	SWITCHED +12 FOR LEFT FRONT RETRACT SOLENOID VALVE
3	BLACK	2400	SWITCHED +12 FOR RIGHT FRONT EXTEND SOLENOID VALVE
4	BLACK	2500	SWITCHED +12 FOR RIGHT FRONT RETRACT SOLENOID VALVE
5	BLACK	4400	SWITCHED +12 FOR LEFT REAR EXTEND SOLENOID VALVE
6	BLACK	4500	SWITCHED +12 FOR LEFT REAR RETRACT SOLENOID VALVE
7	BLACK	3400	SWITCHED +12 FOR RIGHT REAR EXTEND SOLENOID VALVE
8	BLACK	3500	SWITCHED +12 FOR RIGHT REAR RETRACT SOLENOID VALVE
9	BLACK	9300	SWITCHED +12 FOR AIR DUMP VALVES
10	BLACK	9301	SWITCHED +12 FOR AIR TRAVEL VALVES - NOT USED
11 AND 12			NO CONNECTION
<b>CN100</b>			<b>12 PIN GRAY CONNECTOR</b>
1	BLACK	1000	LEFT FRONT JACK WARNING SWITCH - SWITCHED GROUND
2	BLACK	2000	RIGHT FRONT JACK WARNING SWITCH - SWITCHED GROUND
3	BLACK	3000	RIGHT REAR JACK WARNING SWITCH - SWITCHED GROUND
4	BLACK	4000	LEFT REAR JACK WARNING SWITCH - SWITCHED GROUND
5			NO CONNECTION
6	WHITE	6235	GROUND
7			NO CONNECTION
8	BLACK	2200	RIGHT FRONT JACK PRESSURE SWITCH - SWITCHED GROUND
9	BLACK	4200	LEFT REAR JACK PRESSURE SWITCH - SWITCHED GROUND
10	BLACK	3200	RIGHT REAR JACK PRESSURE SWITCH - SWITCHED GROUND
11			NO CONNECTION
12	BLACK	1200	LEFT FRONT JACK PRESSURE SWITCH - SWITCHED GROUND

# ELECTRICAL CONNECTION DIAGRAM

## CENTRAL CONTROL MODULE

### LED - FUSE LOCATION AND DESCRIPTION - PAGE 4 OF 5

#### CENTRAL CONTROL MOTHER BOARD

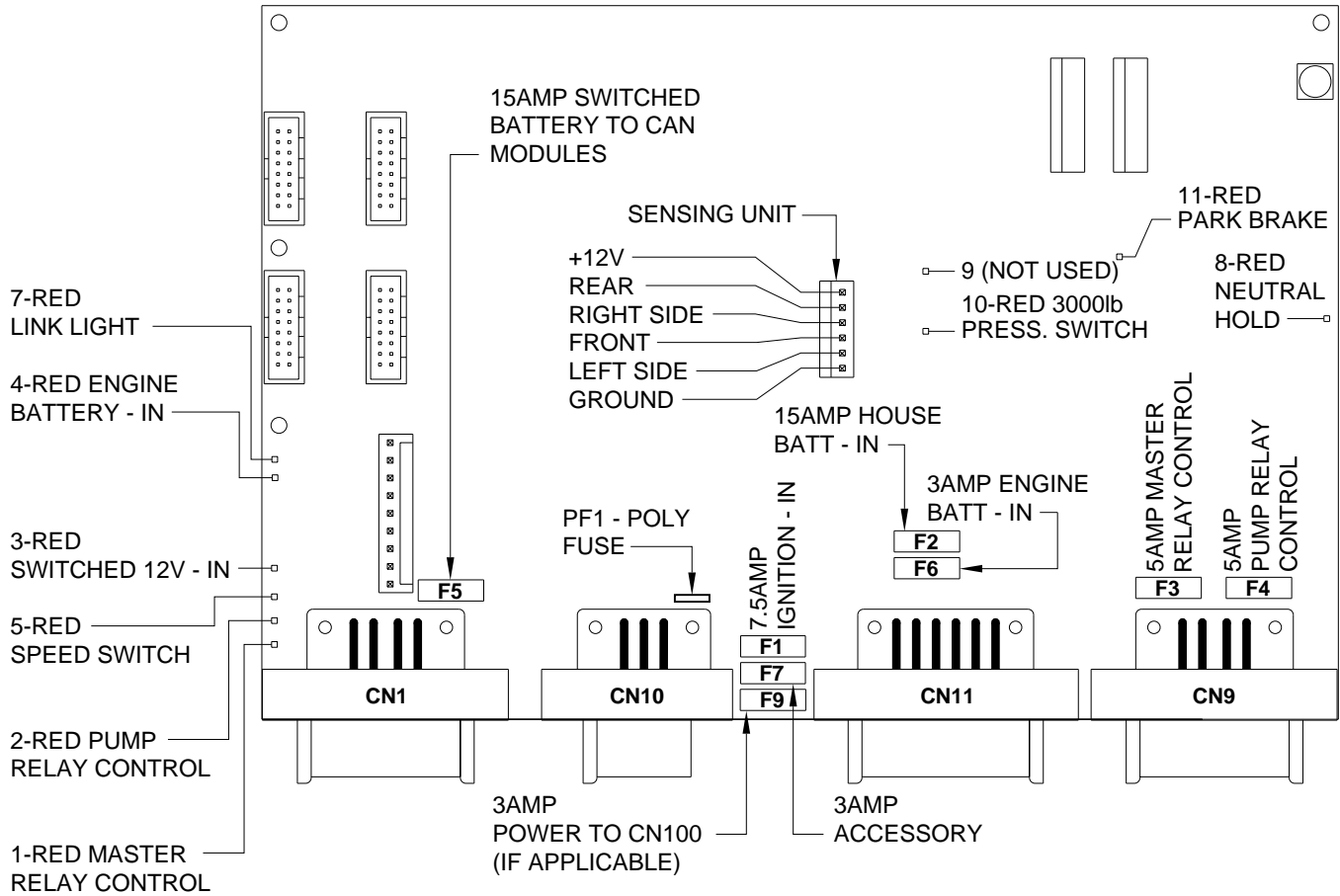

LED	DESCRIPTION	CN AND PIN	FUSE DESCRIPTION
1-RED	MASTER RELAY CONTROL	CN 9 - PIN 1	PF1 - POLY FUSE - POWER TO MASTER WARNING LIGHT AND RESET SWITCH F1 - 7.5AMP IGNITION - IN F2 - 15AMP HOUSE BATTERY - IN F3 - 5AMP MASTER RELAY CONTROL F4 - 5AMP PUMP RELAY CONTROL F5 - 15AMP SWITCHED BATTERY - IN F6 - 3AMP RESET OUT F7 - 3AMP ACCESSORY - IN F9 - 3AMP POWER TO CN100 (IF APPLICABLE)
2-RED	PUMP RELAY CONTROL	CN 9 - PIN 4	
3-RED	SWITCHED 12V FROM MASTER RELAY	CN 1 - PIN 3	
4-RED	ENGINE BATTERY - IN	CN 11 - PIN 12	
5-RED	NOT USED	CN 9 - PIN 5	
7-RED	LINK LIGHT	CN 1 - PIN 7 & 8	
8-RED	NOT USED	CN 11 - PIN 8 & 9	
9-NOT USED	NOT USED	NOT USED	
10-RED	3000 LBS PRESS SWITCH - ON	CN 9 - PIN 2	
11-RED	PARK BRAKE - ON	CN 11 - PIN 11	

**NOTE: FOR DETAILED INPUT / OUTPUT INFORMATION ABOUT PIN CONNECTIONS SEE ELECTRICAL CONNECTION DIAGRAM - CENTRAL CONTROL / MODULE CONNECTION INFORMATION - PAGE 1 OF 5.**

# ELECTRICAL CONNECTION DIAGRAM

## CENTRAL CONTROL MODULE

### LED - FUSE LOCATION AND DESCRIPTION - PAGE 5 OF 5

#### OUTPUT BOARD

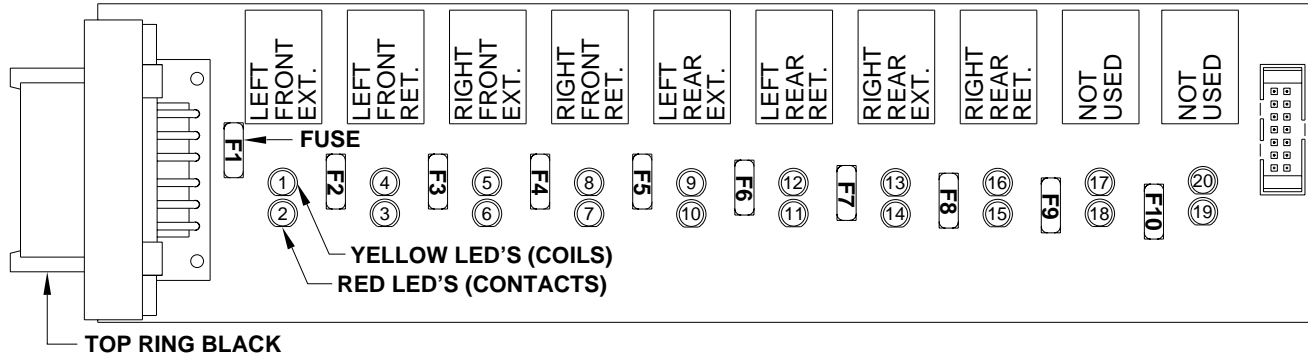

LED	RELAY DESCRIPTION	FUSE	BLACK
1-YELLOW	LEFT FRONT EXT. - COIL	F1-15 AMP	PIN 1
2-RED	LEFT FRONT EXT. - CONTACT		PIN 2
3-RED	LEFT FRONT RET. - CONTACT	F2-15 AMP	
4-YELLOW	LEFT FRONT RET. - COIL		
5-YELLOW	RIGHT FRONT EXT. - COIL	F3-15 AMP	PIN 3
6-RED	RIGHT FRONT EXT. - CONTACT	F4-15 AMP	PIN 4
7-RED	RIGHT FRONT RET. - CONTACT		
8-YELLOW	RIGHT FRONT RET. - COIL		
9-YELLOW	LEFT REAR EXT. - COIL	F5-15 AMP	PIN 5
10-RED	LEFT REAR EXT. - CONTACT	F6-15 AMP	PIN 6
11-RED	LEFT REAR RET. - CONTACT		
12-YELLOW	LEFT REAR RET. - COIL		
13-YELLOW	RIGHT REAR EXT. - COIL	F7-15 AMP	PIN 7
14-RED	RIGHT REAR EXT. - CONTACT	F8-15 AMP	PIN 8
15-RED	RIGHT REAR RET. - CONTACT		
16-YELLOW	RIGHT REAR RET. - COIL		
17-YELLOW	NOT USED		
18-RED	NOT USED	F9-15 AMP	PIN 9
19-RED	NOT USED	F10-15 AMP	PIN 10
20-YELLOW	NOT USED		

**NOTE: FOR DETAILED INPUT / OUTPUT INFORMATION ABOUT PIN CONNECTIONS SEE ELECTRICAL CONNECTION DIAGRAM - CONTROL MODULE CONNECTION INFORMATION - PAGE 3 OF 5.**

**NOTE: A LIT YELLOW LED INDICATES THERE IS A GROUND SIGNAL TO TURN THE CORRESPONDING RELAY ON.**

**A LIT RED LED INDICATES THERE IS VOLTAGE ON IT'S CORRESPONDING CN1 PIN.**

**IF A YELLOW LED IS LIT AND THE CORRESPONDING RED LED IS OFF, EITHER IT'S FUSE IS BLOWN OR THE RELAY IS BAD.**

**IF THE YELLOW LEDS ARE WORKING BUT NO RED LED IS COMING ON THERE MAY BE PROBLEM WITH INPUT VOLTAGE FROM THE 4-PIN CONNECTOR.**

**IF A YELLOW LED IS NOT LIT, THIS INDICATES A POSSIBLE PROBLEM WITH THE MODULE.**

#### HYDRAULIC PRESSURE AND WARNING SWITCH INPUTS

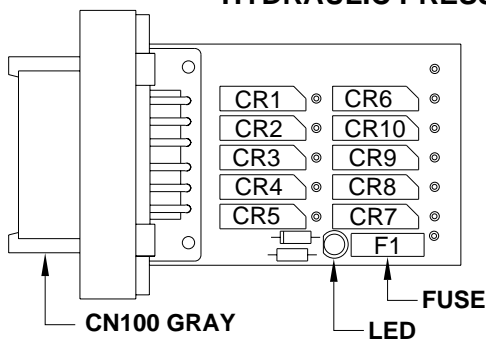

**NOTE: FOR DETAILED INPUT / OUTPUT INFORMATION ABOUT PIN CONNECTIONS SEE ELECTRICAL CONNECTION DIAGRAM - CENTRAL CONTROL / FRONT AIR / GEN SLIDE MODULE CONNECTION INFORMATION - PAGE 3 OF 5.**

READ SWITCH	DESCRIPTION
CR1 - PIN 1	HYD LEFT FRONT WARN SW
CR2 - PIN 2	HYD RIGHT FRONT WARN SW
CR3 - PIN 3	HYD RIGHT REAR WARN SW
CR4 - PIN 4	HYD LEFT REAR WARN SW
CR5 - PIN 5	NOT USED
CR6 - PIN 12	HYD LEFT FRONT PRESS SW
CR7 - PIN 8	HYD RIGHT FRONT PRESS SW
CR8 - PIN 9	HYD LEFT REAR PRESS SW
CR9 - PIN 10	HYD RIGHT REAR PRESS SW
CR10 - PIN 11	NOT USED
PIN 6	GROUND
PIN 7	NOT USED
<b>FUSE - F1</b>	<b>3 AMP SWITCHED BATTERY</b>
<b>LED - RED</b>	<b>+12 POWER TO BOARD</b>

# ELECTRICAL CONNECTION DIAGRAM

## 2000 SERIES CAN SYSTEM

### LEVELING MANIFOLD CONNECTIONS

\* THIS MAY BE A SMALL VALVE ON SOME UNITS

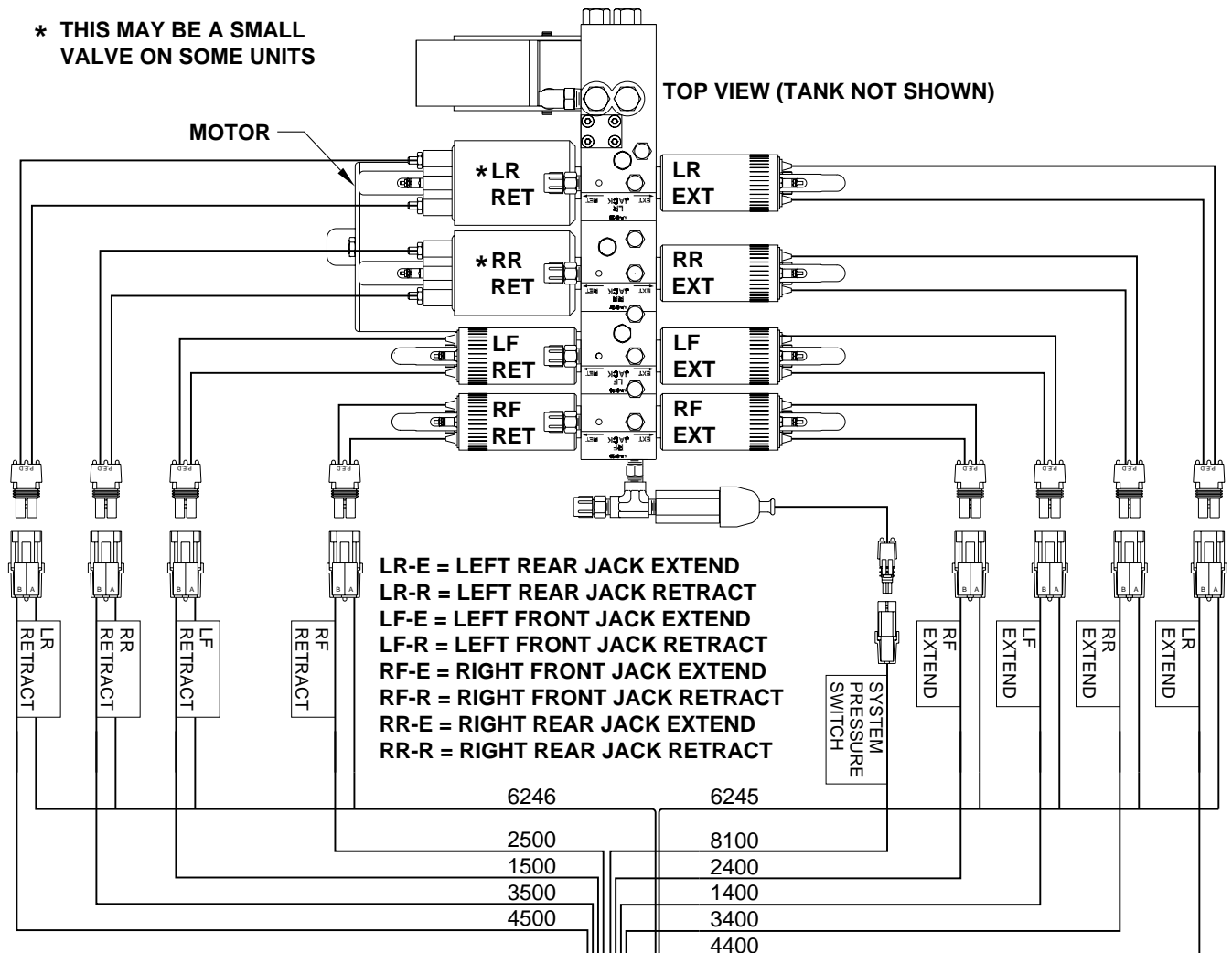

LR-E = LEFT REAR JACK EXTEND  
 LR-R = LEFT REAR JACK RETRACT  
 LF-E = LEFT FRONT JACK EXTEND  
 LF-R = LEFT FRONT JACK RETRACT  
 RF-E = RIGHT FRONT JACK EXTEND  
 RF-R = RIGHT FRONT JACK RETRACT  
 RR-E = RIGHT REAR JACK EXTEND  
 RR-R = RIGHT REAR JACK RETRACT

6230 →

**SEE ELECTRICAL CONNECTION DIAGRAM  
 MASTER AND PUMP RELAYS - PAGE 1 OF 2**

6230  
6245  
6246

**TO HWH  
 CENTRAL  
 GROUND  
 ON PUMP**

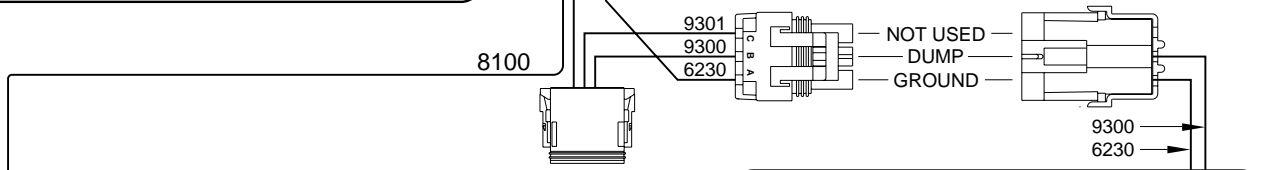

**SEE ELECTRICAL CONNECTION DIAGRAM  
 CENTRAL CONTROL MODULE  
 HARNESS ROUTING - PAGE 3 OF 4**

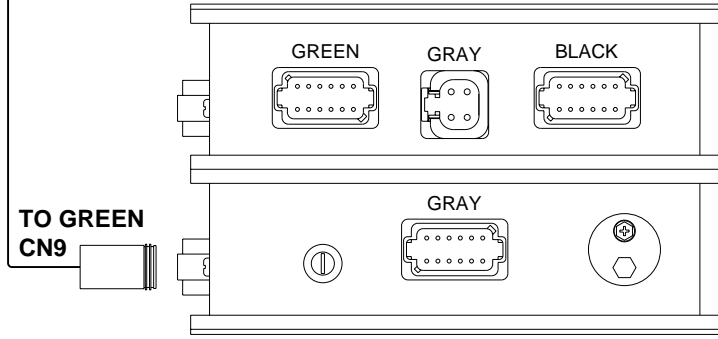

**SEE ELECTRICAL CONNECTION DIAGRAM -  
 CENTRAL CONTROL MODULE - WIRE AND  
 CONNECTION INFORMATION - PAGE 3 OF 5  
 FOR WIRE AND CONNECTOR PIN INFORMATION**

# ELECTRICAL CONNECTION DIAGRAM

## REMOTE STEP MANIFOLD CONNECTIONS

### ROOM 1 - ROOM 2

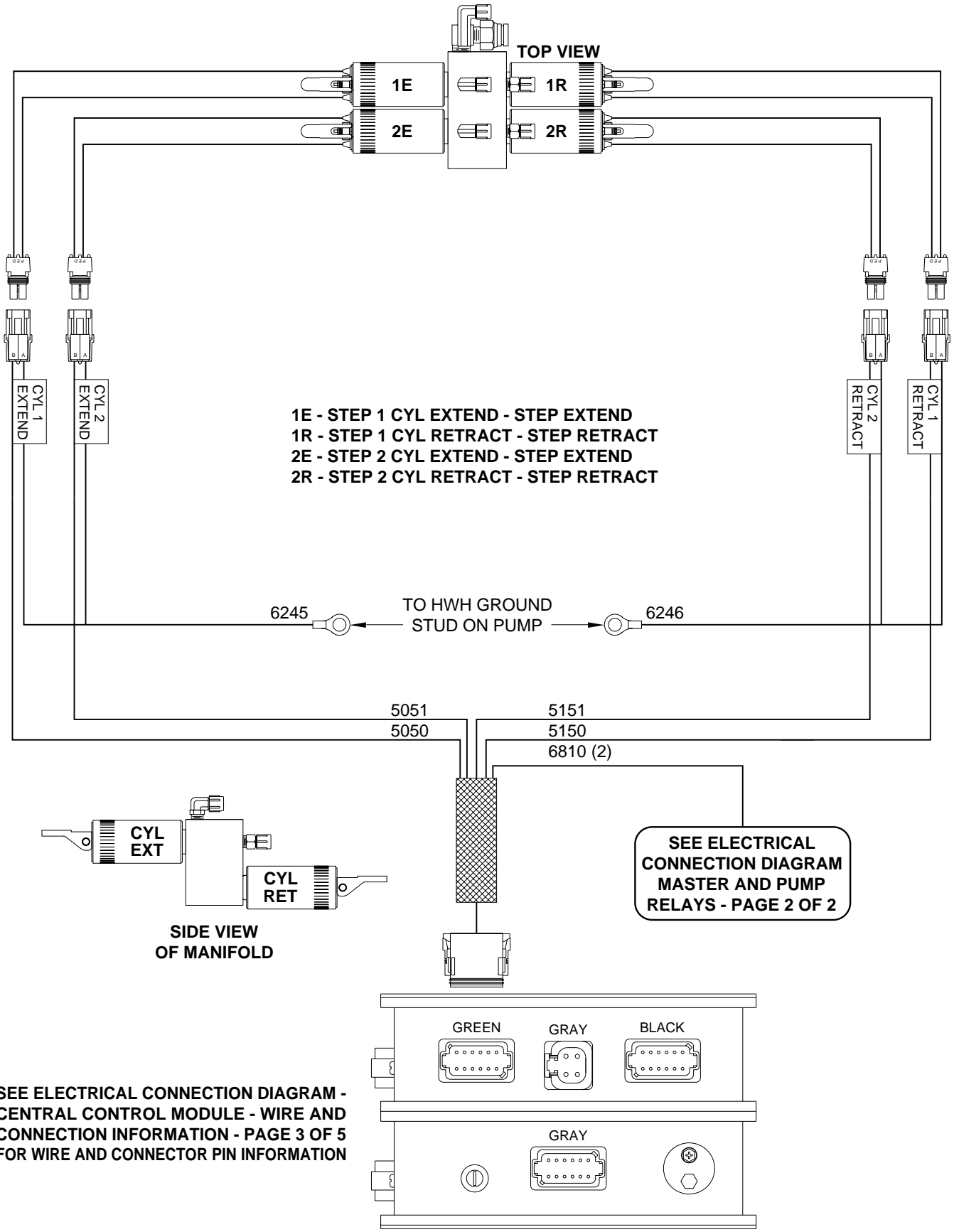

SEE ELECTRICAL CONNECTION DIAGRAM - CENTRAL CONTROL MODULE - WIRE AND CONNECTION INFORMATION - PAGE 3 OF 5 FOR WIRE AND CONNECTOR PIN INFORMATION



# ELECTRICAL CONNECTION DIAGRAM

## MASTER AND PUMP RELAYS

### PAGE 1 OF 2

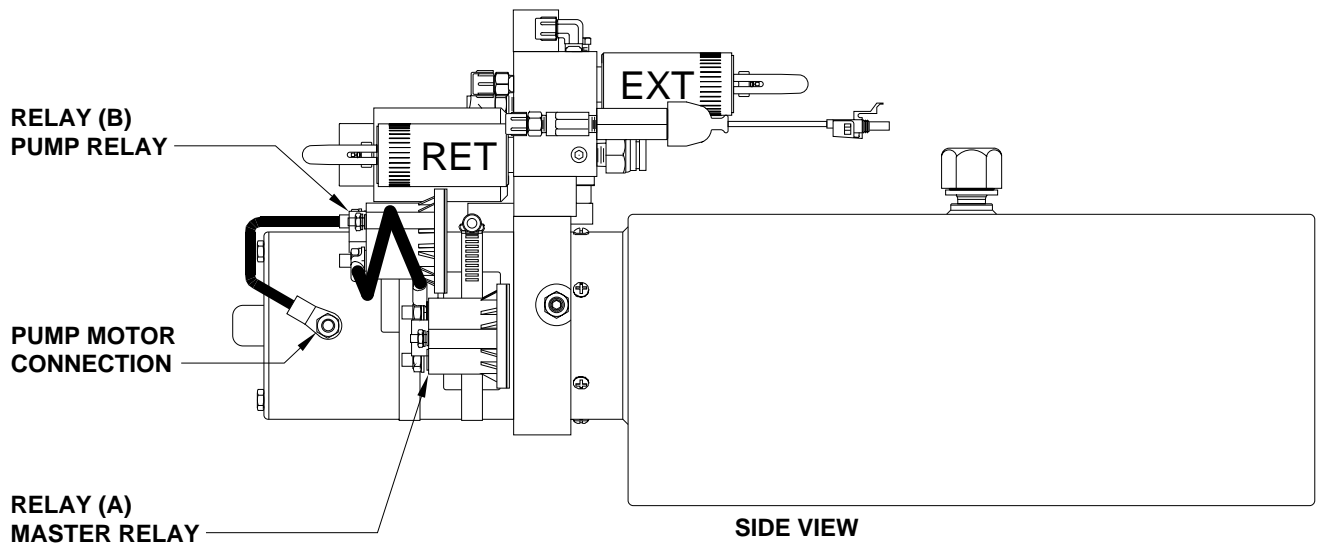
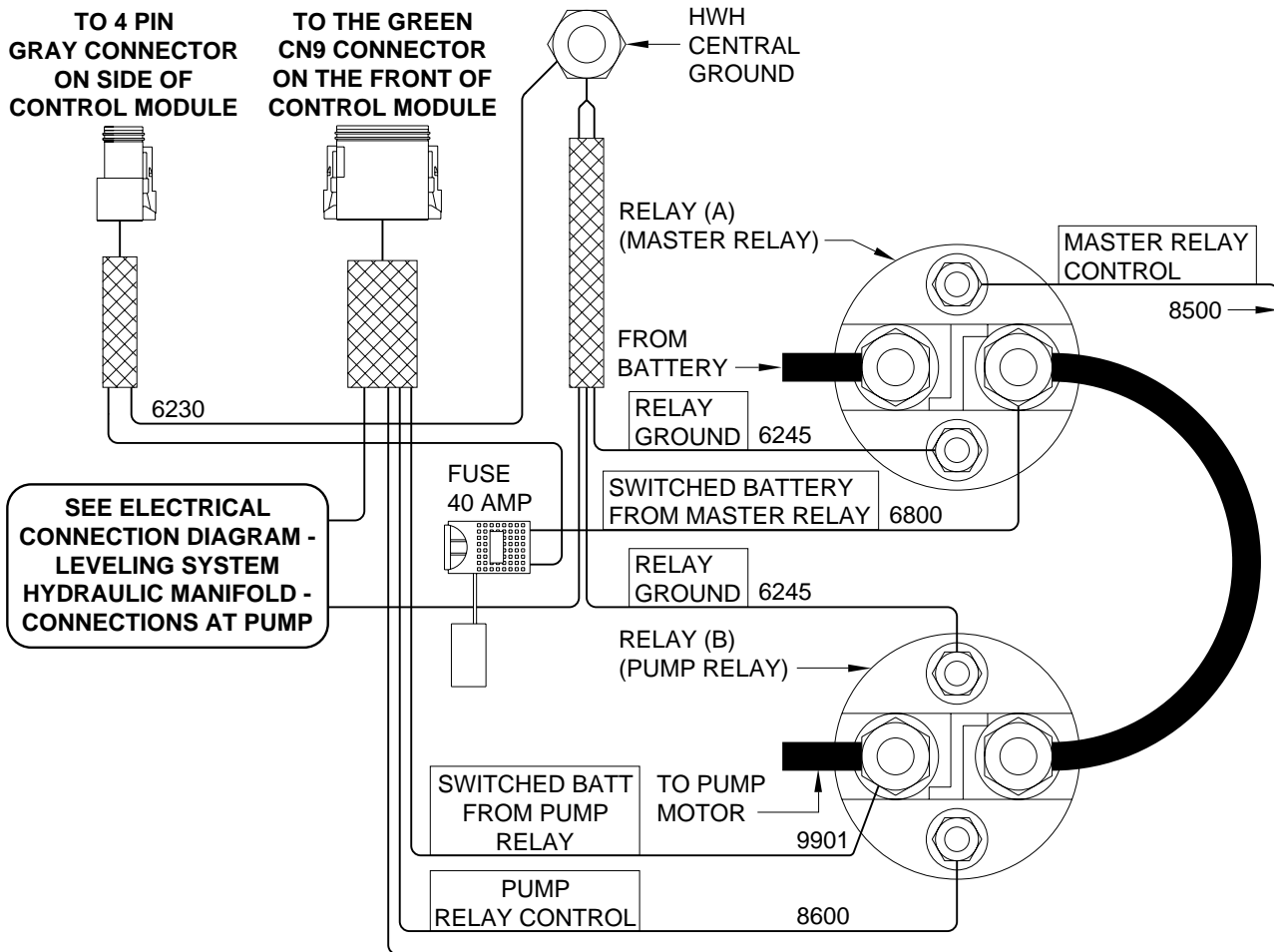

# ELECTRICAL CONNECTION DIAGRAM

## MASTER AND PUMP RELAYS

### PAGE 2 OF 2

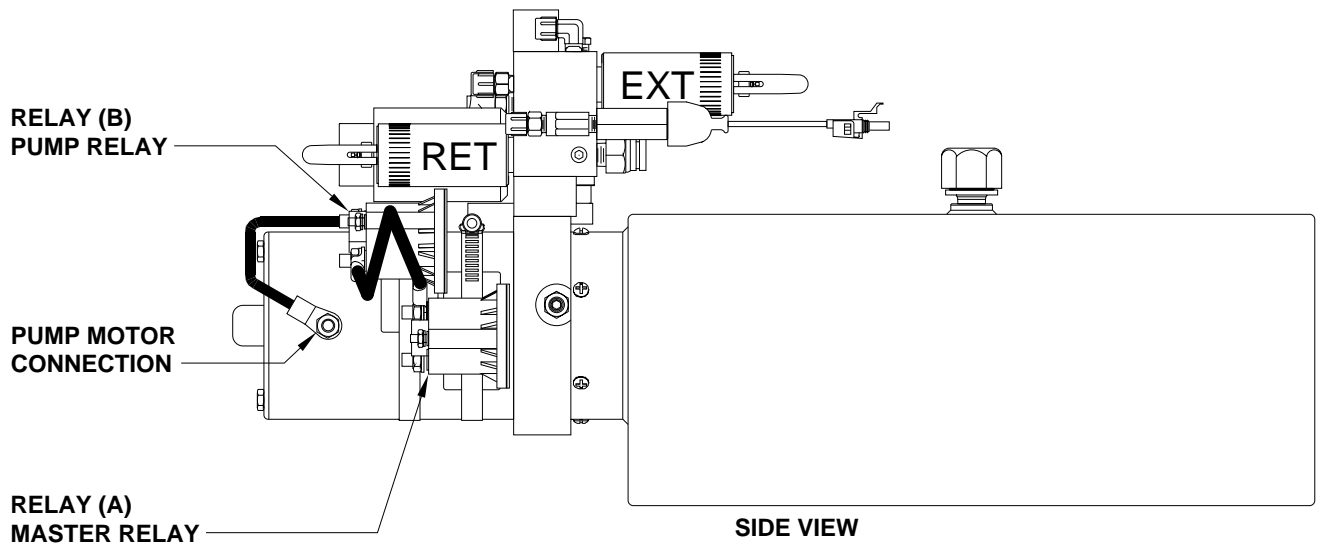
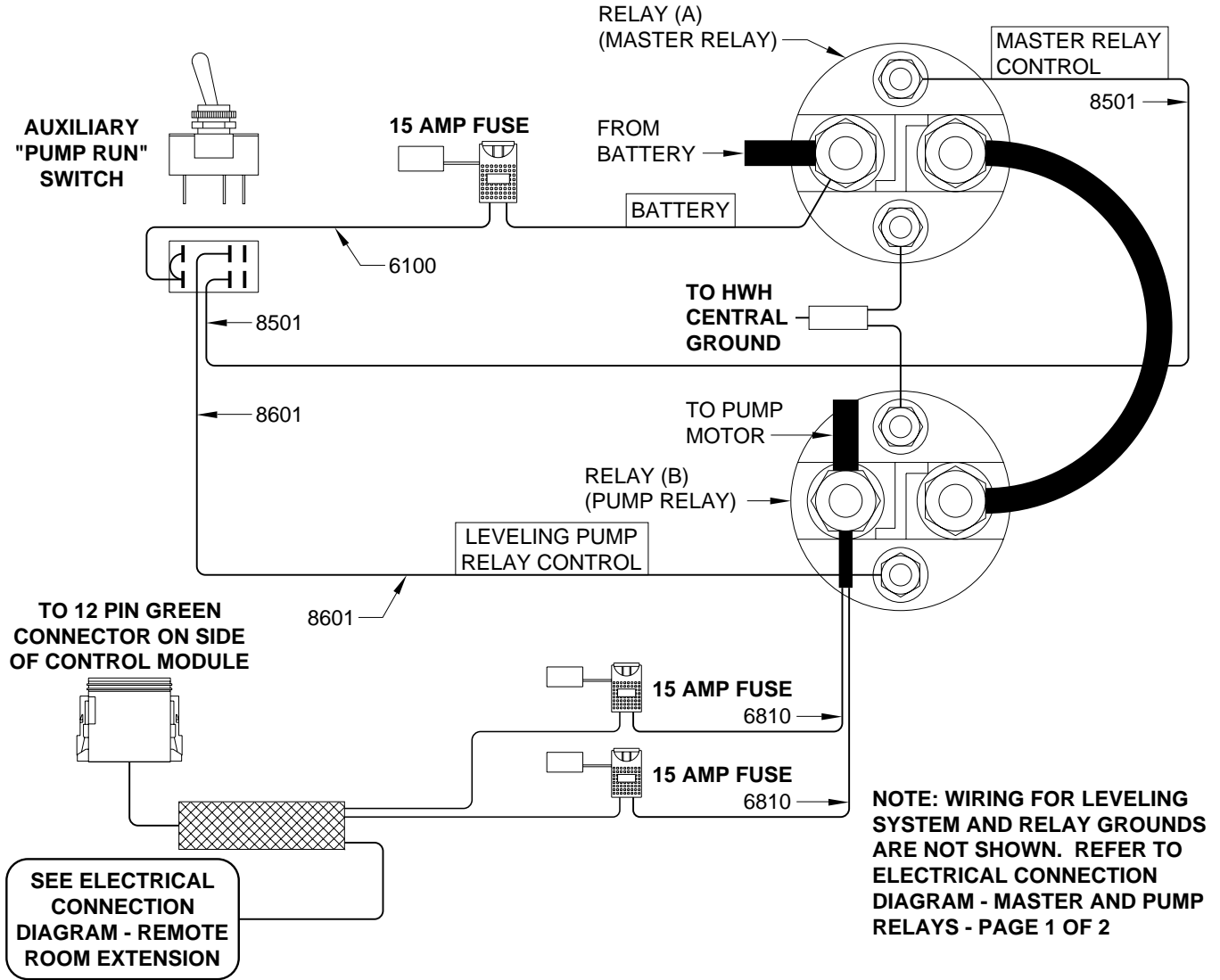

# ELECTRICAL CONNECTION DIAGRAM

## 625S/2000 SERIES LEVELING SYSTEMS

### SINGLE STEP TOUCH PANEL CONNECTIONS

625S/2000 SERIES

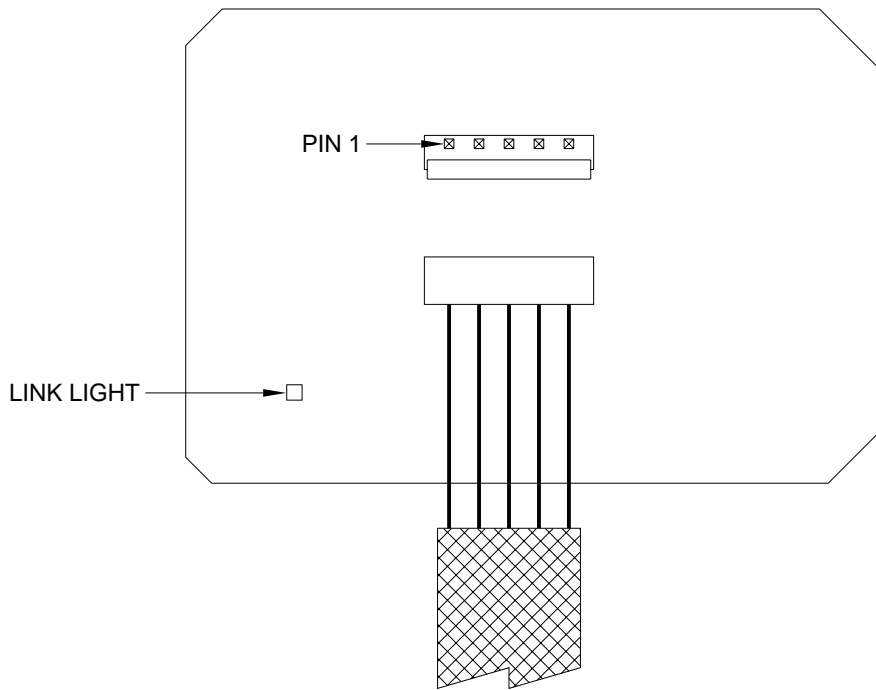
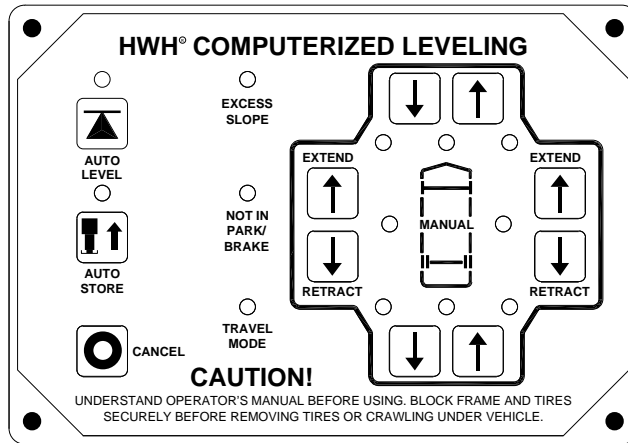

PIN #	WIRE COLOR	WIRE NUMBER	WIRE DESCRIPTION AND FUNCTION
1	YELLOW		CAN HIGH
2	GREEN		CAN LOW
3			CAN SHIELD
4	WHITE	6230	GROUND FROM CONTROL BOX
5	RED	6800	SWITCHED BATTERY FROM CONTROL BOX

# MASTER WARNING LIGHT/BUZZER CONNECTION DIAGRAM

## 2000 SERIES LEVELING SYSTEM

A MASTER WARNING INDICATOR SHOULD ALWAYS BE USED. WHEN THE LEVELING SYSTEM HAS STRAIGHT-ACTING JACKS A WARNING BUZZER MUST BE USED.

**NOTE: BY SUPPLYING IGNITION POWER TO THE WARNING BUZZER, AND "ACC" POWER TO THE WARNING LIGHT, THE SYSTEM MAY BE OPERATED IN ACCESSORY WITHOUT THE BUZZER SOUNDING. THE GROUND SIGNAL FOR THE WARNING INDICATORS MUST ALWAYS COME FROM THE TOUCH PANEL.**

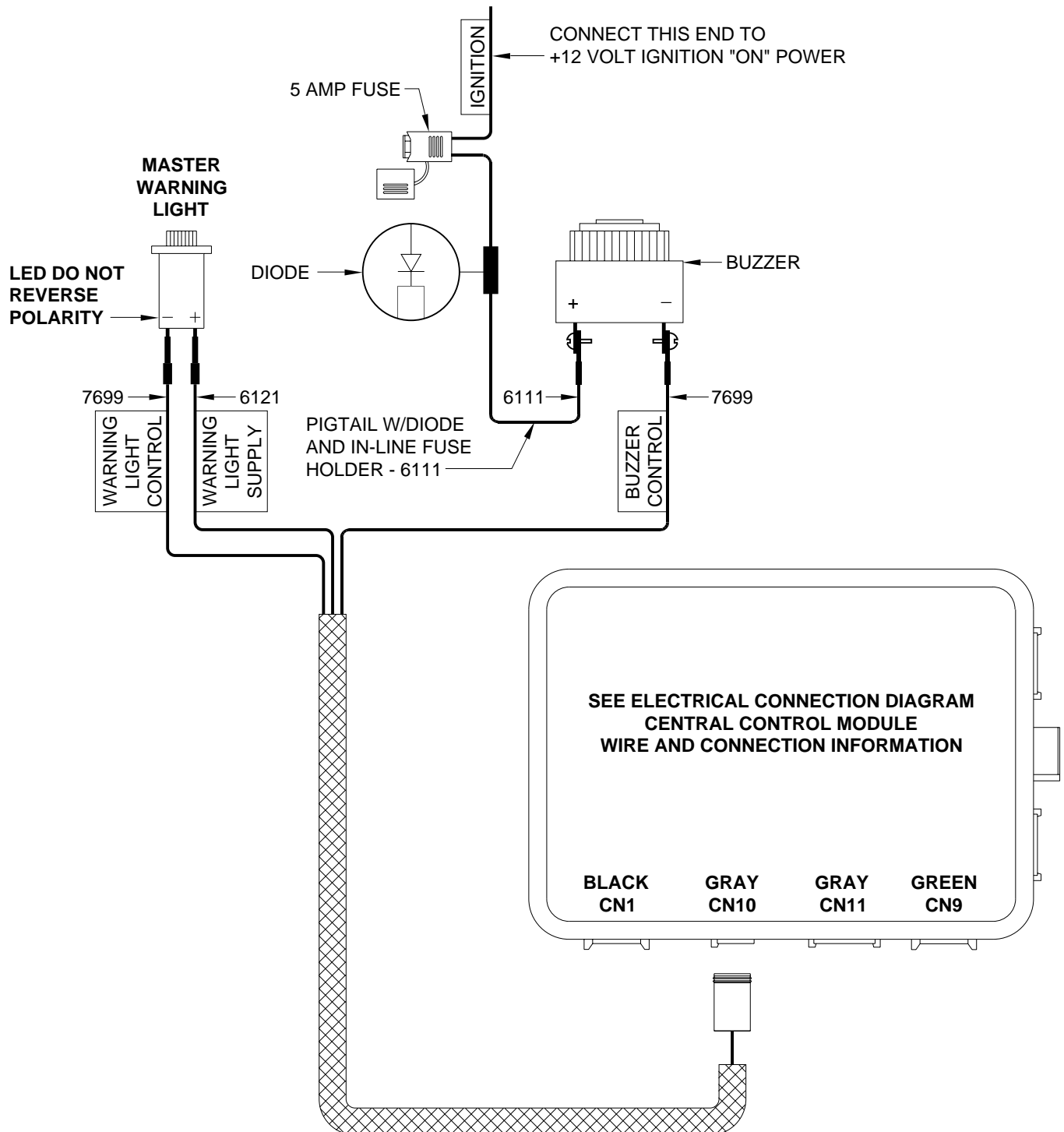

# INFORMATION/INSTRUCTION SHEET

## HYDRAULIC SOLENOID VALVE

### IDENTIFICATION - MANUAL OPERATIONS - REPLACEMENT

**REPLACEMENT VALVES WILL HAVE A VALVE RELEASE CAM**

#### BREATHER CAP W/NUT DRIVER

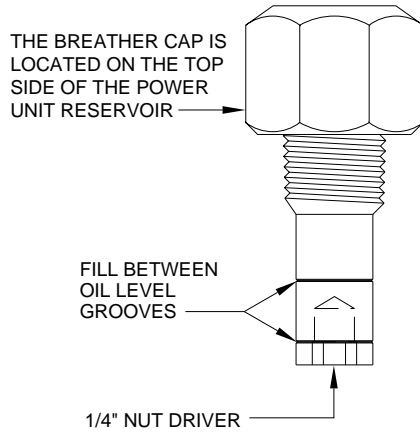

**IMPORTANT: PRIOR TO REMOVING THE BREATHER CAP, EITHER TO CHECK THE OIL LEVEL OR TO USE 1/4" NUT DRIVER, CLEAN ANY DEBRIS FROM THE TOP OF THE RESERVOIR. BEFORE RETURNING THE BREATHER CAP TO THE RESERVOIR, REMOVE ANY PAINT CHIPS OR OTHER DEBRIS FROM THE DIPSTICK INCLUDING DEBRIS INSIDE THE 1/4" NUT DRIVER.**

#### SOLENOID VALVES WITH CAM RELEASE

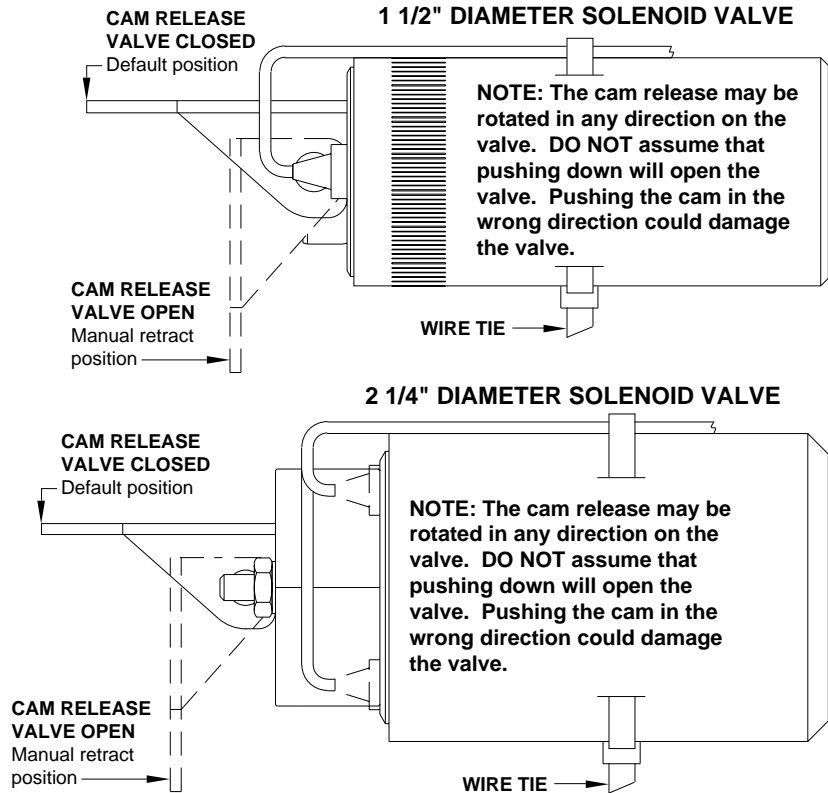

#### SOLENOID VALVES WITH 1/4" NUT RELEASE

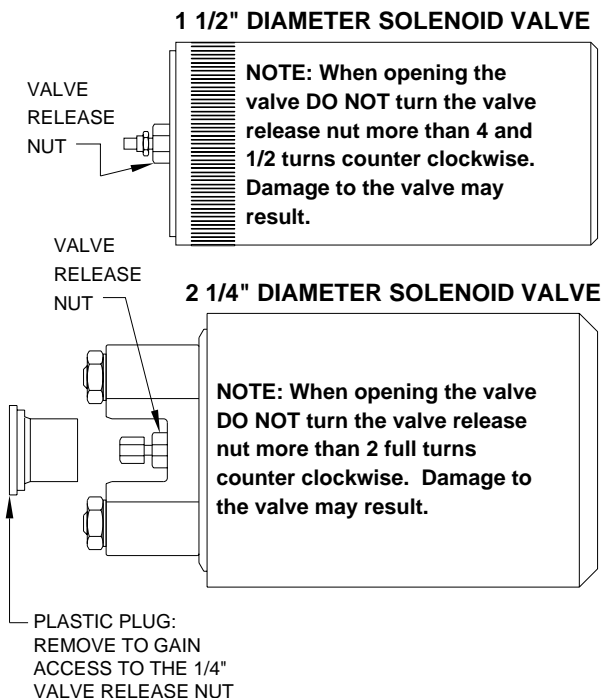

#### SOLENOID VALVES WITH T-HANDLE RELEASE

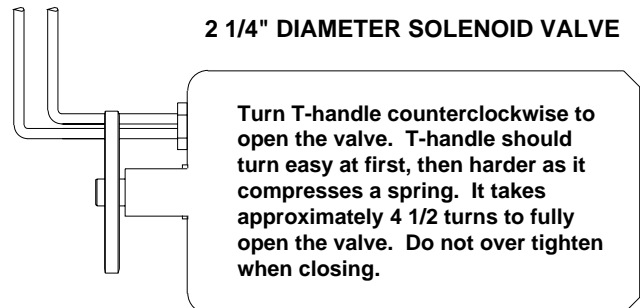

**NOTE: OLD STYLE HEX SHAPED SOLENOID VALVES HAVE NO MANUAL VALVE RELEASE.**