



# OPERATOR'S MANUAL

## HWH® 725 Series, Computer-Controlled Hydraulic Leveling System For Trailers

### FEATURING:

- Touch Panel Leveling Control*
- Four Straight-Acting Power Extend/Power Retract Jacks*
- 208 VAC Three Phase Pump*
- 12 VDC Auxiliary Pump*

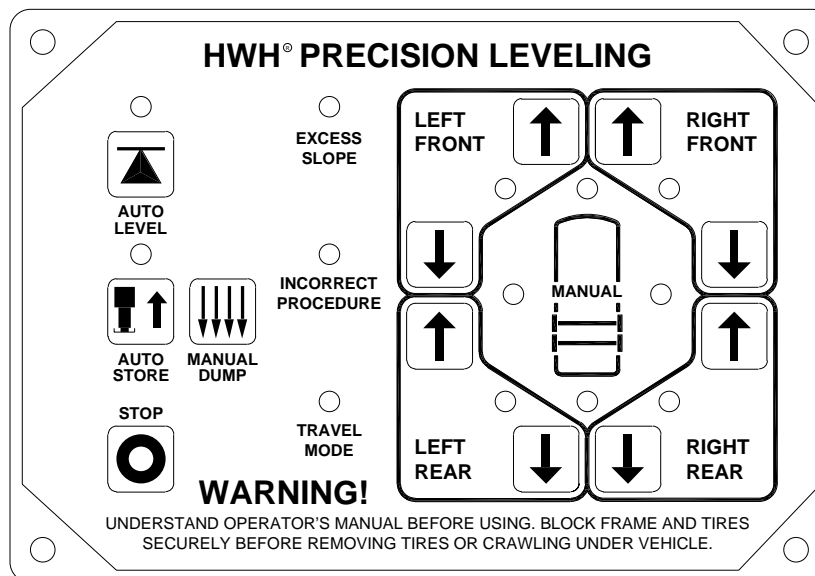

### HWH CORPORATION

(On I-80, Exit 267 South)

2096 Moscow Road | Moscow, Iowa 52760

Ph: 800/321-3494 (or) 563/724-3396 | Fax: 563/724-3408

[www.hwh.com](http://www.hwh.com)

---

# OPERATOR'S MANUAL

---

## WARNING !

**READ THE ENTIRE OPERATOR'S MANUAL BEFORE OPERATING.**

**BLOCK FRAME AND TIRES SECURELY BEFORE CRAWLING UNDER VEHICLE. DO NOT USE LEVELING JACKS OR AIR SUSPENSION TO SUPPORT VEHICLE WHILE UNDER VEHICLE OR CHANGING TIRES. VEHICLE MAY DROP AND/OR MOVE FORWARD OR BACKWARD WITHOUT WARNING CAUSING INJURY OR DEATH.**

**KEEP ALL PEOPLE CLEAR OF VEHICLE WHILE LEVELING SYSTEM IS IN USE.**

**WHILE HITCHING OR UNHITCHING, AVOID AREAS WHERE BODY MAY BE CRUSHED BY SUDDEN DROPPING OR SLIDING OF THE TRAILER.**

**DO NOT LIFT TOW VEHICLE WITH LEVELING SYSTEM.**

**NEVER PLACE HANDS OR OTHER PARTS OF THE BODY NEAR HYDRAULIC LEAKS. OIL MAY PENETRATE SKIN CAUSING INJURY OR DEATH.**

**WEAR SAFETY GLASSES WHEN INSPECTING OR SERVICING THE SYSTEM TO PROTECT EYES FROM DIRT, METAL CHIPS, OIL LEAKS, ETC. FOLLOW ALL OTHER APPLICABLE SHOP SAFETY PRACTICES.**

**IMPORTANT: IF VEHICLE IS EQUIPPED WITH A ROOM EXTENSION, READ ROOM EXTENSION SECTION BEFORE OPERATING LEVELING SYSTEM.**

## HOW TO OBTAIN WARRANTY SERVICE

### THIS IS NOT TO BE INTERPRETED AS A STATEMENT OF WARRANTY

HWH CORPORATION strives to maintain the highest level of customer satisfaction. Therefore, if you discover a defect or problem, please do the following:

**FIRST:** Notify the dealership where you purchased the vehicle or had the leveling system installed. Dealership management people are in the best position to resolve the problem quickly. If the dealer has difficulty solving the problem, he should immediately contact the Customer Service Department, at HWH CORPORATION.

**SECOND:** If your dealer cannot or will not solve the problem, notify the Customer Service Department:  
HWH CORPORATION 2096 Moscow Rd. Moscow IA. 52760  
(563) 724-3396 OR (800) 321-3494. Give your name and address, coach manufacturer and model year, date the coach was purchased, or the date of system installation,

description of the problem, and where you can be reached during business hours (8:00 a.m. till 5:00 p.m. c.s.t.). HWH CORPORATION personnel will contact you to determine whether or not your claim is valid. If it is, HWH CORPORATION will authorize repair or replacement of the defective part, either by appointment at the factory or by the authorization of an independent service facility, to be determined by HWH CORPORATION. All warranty repairs must be performed by an independent service facility authorized by HWH CORPORATION, or at the HWH CORPORATION factory, unless prior written approval has been obtained from proper HWH CORPORATION personnel.

# CONTROL IDENTIFICATION

## 2000 SERIES PRECISION LEVELING SYSTEM

### COMPUTER-CONTROL

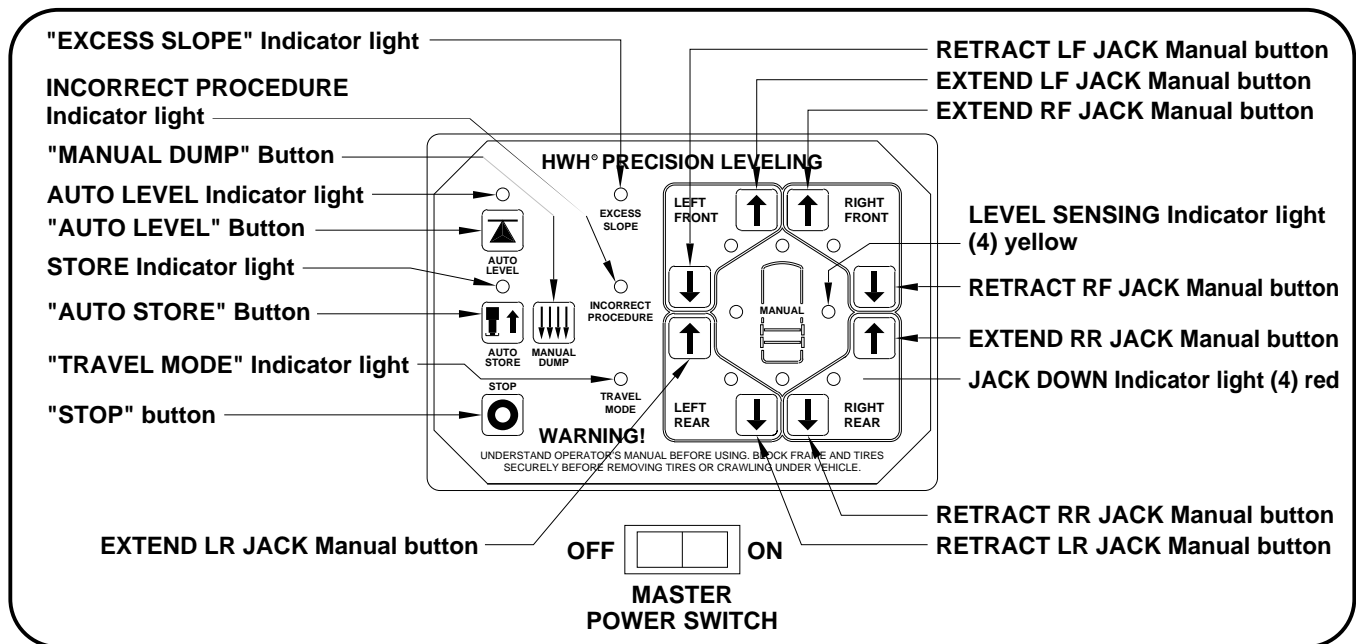

## CONTROL FUNCTIONS

### AUTO CONTROL BUTTONS

**"AUTO LEVEL" (▲) BUTTON:** This is the on button and automatic operation button.

**"STOP" BUTTON:** Push the "STOP" button to stop automatic hydraulic operation.

**"AUTO STORE" BUTTON:** The store indicator light is above the "AUTO STORE" button. This button is used to automatically retract the jacks.

### MANUAL CONTROL BUTTONS

**EXTEND BUTTONS (UP ARROWS):** These buttons will extend the jacks to lift the vehicle.

**RETRACT BUTTONS (DOWN ARROWS):** These buttons will retract the jacks to lower the vehicle.

**"MANUAL DUMP" BUTTON:** Not used

SEE MANUAL LEVELING PROCEDURE.

**MASTER POWER SWITCH:** This switch controls power to the leveling system.

### INDICATOR LIGHTS

**AUTO LEVEL INDICATOR LIGHT: (RED)** This light indicates that the panel is active in the auto level or maintain mode.

### INDICATOR LIGHTS

**AUTO STORE LIGHT: (RED)** This light indicates that the system is in STORE mode.

**"EXCESS SLOPE" LIGHT: (RED)** This indicator will light when the leveling system cannot level the vehicle.

**"INCORRECT PROCEDURE" LIGHT: (RED)** This light flashes if certain specific procedures are not followed. See "INCORRECT PROCEDURE LIGHT" page.

**"TRAVEL MODE" LIGHT: (GREEN)** This LED, indicates the leveling system is in the travel mode. All jack down warning lights should be off.

**LEVELING LIGHTS:** The four yellow indicating lights are level sensing indicators. When a yellow light is on, it indicates that its side, end, or corner of the vehicle is low. The front and rear lights should not be on at the same time. Because of the level sensor arrangement, both side lights can be on at the same time.

**JACK DOWN LIGHTS:** The four red lights surrounding the yellow level indicators are jacks down WARNING lights. They are functional when the Master Power switch is on. When a jack is extended approximately 1 inch, its warning light will come on.

---

# CONTROL IDENTIFICATION

## PUMP RUN TIME

---

### PUMP RUN TIME

Pump motors used with HWH leveling systems and room extension systems come in 3 different diameters; 3", 3.7" and 4.5". Contact the vehicle manufacturer or HWH for help with identifying the motor size. **It is important that any time the pump runs for more than three minutes with a 3" motor; or six minutes with a 3.7" or 4.5" motor that the motor is allowed to cool for thirty minutes before continuing. Continuous operation of the pump motor without allowing the motor to cool can damage the motor.** For cold weather information see "COLD WEATHER OPERATIONS" below.

The HWH systems with a computer processor monitor the pump run time and will turn the pump off if the run time exceeds a specified time. This time can vary with different systems. Due to available electronics or system design, the pump run time programs will also vary. Leveling systems and room extensions that are not controlled by a system processor have no pump run time protection. **DO NOT run the pump more than three or six minutes without allowing the pump motor to cool for thirty minutes.**

#### SYSTEM VARIATIONS FOR PUMP RUN TIME

Some systems with rooms run the rooms separate from the system processor. These systems do not monitor pump run time when operating the rooms. **DO NOT run the pump more than three or six minutes without allowing the pump motor to cool for thirty minutes.**

Some systems can be turned back on immediately after the processor turns the pump off. **DO NOT turn the system back on or run the pump without allowing the pump motor to cool for thirty minutes.**

When operating some leveling systems manually or operating the room extensions, the pump will turn off and back on while pushing the control button when the pump run time has been exceeded. **DO NOT continue without allowing the pump motor to cool for thirty minutes.**

With some systems, when the processor has turned the pump off because the run time has been exceeded, power to the HWH system must be turned off and back on before the system will operate. With motorized vehicles, turn the ignition off and back on. With non-motorized vehicles, turn the master power switch for the HWH system off and back on. **DO NOT continue without allowing the pump motor to cool for thirty minutes.**

Some HWH systems are equipped with a lighted reset switch. If the processor turns the pump off because the run time has been exceeded, the light in the reset switch will turn on. The system will not operate until the reset switch is pushed.

**DO NOT continue without allowing the pump motor to cool for thirty minutes.**

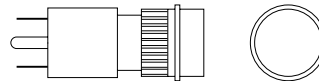

**LIGHTED RESET SWITCH**

**No matter what HWH system is on the vehicle, the pump should not be ran for more than three minutes (3" motors) or six minutes (3.7" or 4.5" motors) without allowing the pump motor to cool for thirty minutes. Continuous operation of the pump motor without allowing the motor to cool can damage the pump motor.**

Contact HWH corporation to get specific information about the system in this vehicle.

## COLD WEATHER OPERATIONS

HWH leveling and room extension systems are designed to function in cold weather down to 0 degrees Fahrenheit. Below freezing (32 degrees Fahrenheit) the jacks or rooms will operate slower than usual.

For operation in temperatures dropping below -20 degrees Fahrenheit, it is necessary that the system is equipped with oil designed for extreme cold weather application such as a synthetic oil. (Contact HWH for recommendations.)

**DO NOT run the pump motor continuously. It is important that any time the pump runs for more than three minutes with a 3" motor; or six minutes with a 3.7" or 4.5" motor that the motor is allowed to cool for thirty minutes before continuing. Continuous operation of the pump motor without allowing the motor to cool can damage the motor.** Continuous operation of the pump with slow moving jacks or rooms in cold weather, without allowing the pump motor to cool will cause the pump motor to burn up and damage the pump assembly.

---

# OPERATING PROCEDURES

---

## GENERAL INSTRUCTIONS

Maintain adequate clearance in all directions for vehicle, room extensions, awnings, doors, steps, etc. Vehicle may move in any direction due to jacks extending or retracting, settling of the jacks or the vehicle, equipment malfunction, etc..

If parking on soft ground or asphalt paving, wood blocks or pads must be placed under the jacks.

**NOTE:** This vehicle may be equipped with equipment interfaces that prevent operation of the leveling system. Refer to the vehicle manufacturer for information concerning equipment interfaces.

Press the "STOP" button and turn the master power switch "OFF" at any time to stop the operation of the system.

**WARNING:** DO NOT MOVE THE VEHICLE IF ONE OR MORE JACKS ARE EXTENDED TO THE GROUND.

The HWH or OEM supplied master power switch must be on for the leveling system to operate. Refer to the vehicle manufacturer for information about a master power switch.

## PREPARATION FOR TRAVEL

Before traveling, the red jack warning lights must be off and the "TRAVEL MODE" light, if so equipped, must be on. If lights are not correct for travel, retract jack as described in the JACK RETRACTION Section.

If the jacks are retracted but a red "WARNING" light is lit or the green "TRAVEL MODE" light is not lit, the system needs to be serviced.

Any room extension should be fully retracted before traveling.

**WARNING:** DO NOT MOVE THE VEHICLE WHILE THE LEVELING JACKS ARE STILL IN CONTACT WITH THE GROUND OR IN THE EXTEND POSITION. THIS

**VEHICLE IS EQUIPPED WITH STRAIGHT-ACTING JACKS. MOVING THE VEHICLE WITH THE LEVELING JACKS EXTENDED CAN CAUSE SEVERE DAMAGE TO THE JACKS AND OR THE VEHICLE AND CREATE A DRIVING HAZARD. DO NOT RELY SOLELY UPON WARNING LIGHTS. IT IS THE OPERATOR'S RESPONSIBILITY TO CHECK THAT ALL JACKS ARE FULLY RETRACTED INTO THE STORE/TRAVEL POSITION.**

Any time the "AUTO LEVEL" button has been pushed, push the "STORE" button before traveling.

If the jacks cannot be retracted according to the JACK RETRACTION Section, retract the jacks according to the MANUAL JACK RETRACTION Section. The system should then be checked.

## ROOM EXTENSION PROCEDURES

**IMPORTANT:** If the vehicle is equipped with a room extension read this section carefully.

**IMPORTANT:** It is recommended to level and stabilize the vehicle before extending the room.

**IMPORTANT:** Extending or retracting any leveling jacks when the room is extended is not recommended.

Refer to the vehicle owner's manual for proper operation of room extensions.

**IMPORTANT:** Do not use a room extension support when the vehicle is supported by the leveling system.

# OPERATING PROCEDURES

## INCORRECT PROCEDURE LIGHT

There are several situations that prevent the "AUTO LEVEL" or "AUTO STORE" buttons from functioning or that will stop the auto leveling process. When these situations occur, the system turns the "INCORRECT PROCEDURE" light on steady and flashes the two front RED warning lights for 10 seconds. After 10 seconds the indicator lights will then return to their normal state. The "INCORRECT PROCEDURE" lights will go out. The front warning lights will remain on if the jacks are extended.

All of the Touch Panel manual buttons will continue to function while the "INCORRECT PROCEDURE" light is on, but the "AUTO LEVEL" or "AUTO STORE" buttons will function only when the situation is corrected.

The following situations will turn the "INCORRECT PROCEDURE" light on and flash the front warning lights.

1. The "AUTO LEVEL" button will not function unless both front jacks are firmly on the ground supporting the weight of the trailer.
2. If the rear YELLOW level light is on, the "AUTO LEVEL" button will not function unless both front jacks are firmly on the ground and both front warning lights are on steady.
3. The "AUTO STORE" button will not function if either front jack is supporting any of the trailer weight.

## PUMP SELECT SWITCH

The system is equipped with two pumps. One pump has a 208 VAC 3-phase motor. The other pump has a 12 VDC motor. The 208 VAC pump should be used as the primary pump with the 12 VDC pump as a back up. To select a pump, put the toggle switch in the desired position. The touch panel, the two switch remote box and the PUMP RUN switch will function with the pump selector switch in either position.

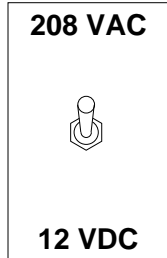

## TWO SWITCH REMOTE PANEL

Refer to the vehicle manufacturer for mounting location of the TWO SWITCH REMOTE PANEL. This panel will operate the two front jacks only. This panel can be used to hitch or unhitch the trailer from the tow vehicle.

**IMPORTANT: REFER TO THE VEHICLE MANUFACTURER FOR HITCHING AND UNHITCHING PROCEDURES.** The master power switch for the leveling system must be on to use the remote switch panel.

To extend or retract the front jacks, push and hold the switches to "EXTEND" or "RETRACT". If desired, both switches can be pushed at the same time.

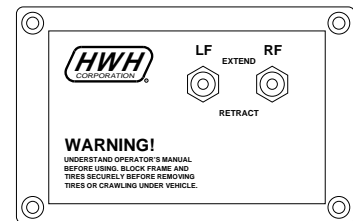

It is not recommended to lift the trailer with one front jack.

## 208 VAC MOTOR STARTER

The motor starter is equipped with a green and red button. The green button is a momentary button. If the 208 VAC is on, the pump will run while the green button is being pushed. The pump will turn off when the button is released. **The green button should only be used if there is a problem with the 12 volt power for the system.**

The red button is a reset button for the motor starter. This will protect the motor if drawing too much current. Any time the 208 VAC motor will not work, try pushing the red button. If the motor will still not work, contact HWH Corporation for assistance.

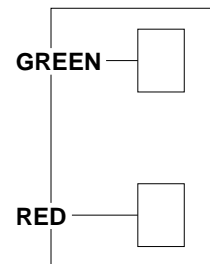

---

# OPERATING PROCEDURES

---

## SET UP AND AUTOMATIC LEVELING PROCEDURE

Trailer must be unhitched from the tow vehicle before leveling. The HWH front jacks may be used to lift the trailer for unhitching. If auxiliary jacks are used to unhitch the trailer, extend the HWH front jacks to the ground and retract the auxiliary jacks before the leveling system is used for leveling.

**NOTE: Refer to the trailer manufacturer owner's manual for unhitching.**

If parking on soft ground or asphalt paving, a wood block or pad should be placed under each jack.

**IMPORTANT: Overheating and excessive current drain will result if raise arrows are operated for an extended period of time.**

1. Turn the HWH master power switch on.
2. Use the front UP arrow manual button to extend the front jacks to unhitch the trailer.

**NOTE: Before unhitching the trailer, the operator may want to check the jacks and place pads under the jacks if the ground will not support the vehicle.**

**IMPORTANT: The "AUTO LEVEL" button will not function unless at least one front jack is firmly on the ground, supporting the weight of the trailer.**

**If the rear yellow level indicator is on, the "AUTO LEVEL" button will not function unless at least one front jack is firmly on the ground supporting the trailer and both front red warning lights are on.**

**If either of the above situations are encountered, the "INCORRECT PROCEDURE" light will come on steady for 10 seconds. Both front warning lights will flash while the "INCORRECT PROCEDURE" light is on. After 10 seconds, the "INCORRECT PROCEDURE" light will shut off and the front warning lights will stop flashing. When the situation has been corrected, the "AUTO LEVEL" button will function. The manual UP and DOWN arrow buttons will function while the "INCORRECT PROCEDURE" light is on.**

3. Push the "AUTO LEVEL" button. The AUTO LEVEL light will flash and the auto leveling procedure will begin.

The system will automatically extend the jacks to level the vehicle and then extend any remaining jacks for stabilizing. The system will level the trailer front to rear (if needed) before leveling side to side. If the rear yellow level indicator is on, the system will lower the front of the trailer to level the trailer. If the front jacks are Double - Acting jacks, the pump will run while the front is lowering. After the system has finished leveling and stabilizing, it will automatically shut off.

During the stabilize portion of the auto leveling sequence, first the system will check the right rear jack pressure switch and extend the jack as necessary. If or when the right rear pressure switch is satisfied, the system checks the left rear jack pressure switch and extends the jack as necessary. If or when the left rear pressure switch is satisfied, the system will check both front jack pressure switches at the same time.

**NOTE: The system will only lower the front of the trailer if the rear level light is on when the "AUTO LEVEL" button is pushed. If the rear light is not on or goes out while lowering the trailer, no lowering procedure is used after that no matter what level light may come on.**

**If either front red warning light goes out while the front is lowering, the system will discontinue the leveling procedure and shut off. The "INCORRECT PROCEDURE" light will come on with the two front warning lights blinking for 10 seconds.**

**EXCESS SLOPE SITUATION:** In the event the jacks are unable to level the coach, the "EXCESS SLOPE" light will come on. Excess slope is two jacks fully extended without turning the yellow level light out. The system will not stabilize the vehicle if the "EXCESS SLOPE" light comes on. One or more jacks may be extended. The system will shut off leaving the "EXCESS SLOPE" light on. The "EXCESS SLOPE" light will remain on if there is power to the control box, until the jacks have been fully retracted using the "STORE" button, turning the red warning lights out. Refer to the HITCHING AND STORING JACKS section. Move the trailer to a more level position or level the trailer as close as possible according to the MANUAL LEVELING section. Manual leveling will operate when the EXCESS SLOPE light is on.

4. Make sure the HWH master power switch is off any time the touch panel is not active whether the jacks are extended or retracted.

---

# OPERATING PROCEDURES

## 625/2000 SERIES LEVELING SYSTEM

---

### HITCHING AND STORING JACKS

**WARNING:** THE OPERATOR MUST BE SURE THAT THERE ARE NO OBJECTS UNDER THE TRAILER AND THAT ALL PEOPLE ARE CLEAR OF THE TRAILER.

#### HITCHING

**IMPORTANT:** The "STORE" button will not function until the weight of the trailer is off the front jacks.

1. The HWH master switch must be on to hitch the trailer and store the jacks.

The manual UP (extend jacks) and DOWN (retract jacks) arrows will function anytime the master power switch is on if the "AUTO LEVEL" or AUTO STORE lights are not flashing.

2. Push the rear down arrow (RETRACT button) until the weight of the trailer is off the rear jacks.

3. Hitch the trailer to the tow vehicle according to the manufacturers instructions. Use the existing landing gear or the front UP (EXTEND jacks) and DOWN (RETRACT jacks) arrows.

**NOTE:** If the trailer is equipped with an air suspension, it is recommended to not connect the tow vehicle air supply to the trailer until the trailer is hitched to the tow vehicle and the jacks are not touching the ground.

#### STORING JACKS

1. After the trailer is securely hitched to the tow vehicle, and the weight of the trailer is off of the front jacks, push the "STORE" button. All 4 jacks will retract.

**NOTE:** If the weight of the trailer is not removed from both front jacks, the "AUTO STORE" button will not function. If the "AUTO STORE" button is pushed, the "INCORRECT PROCEDURE" light will come on steady with the two front warning lights flashing for 10 seconds. The manual UP or DOWN arrow buttons will function while the "INCORRECT PROCEDURE" light is on.

With double-acting front jacks or landing gear, it may be necessary to use the manual front DOWN ARROW button to hitch the trailer to the tow vehicle or slightly retract the front jacks before the "STORE" button will function, even if the front jacks are not supporting the trailer.

The pump will run with all retract loads staying on until 10 seconds after the last red warning light goes out. The jack valves will stay on (open) for an additional 10 seconds. If any warning light remains on the pump and all retract loads will remain on for (6) minutes from the time the "AUTO STORE" button was pushed.

**WARNING:** ONLY USE THE "STORE" BUTTON IF THE TRAILER IS HITCHED TO A TOW VEHICLE OR SECURELY SUPPORTED BY THE EXISTING LANDING GEAR.

**IMPORTANT:** DO NOT interrupt power to the leveling system while the "STORE" indicator light is blinking. DO NOT push the "OFF" button or turn power off to the system. The system must be allowed to completely finish the STORE mode.

**WARNING:** DO NOT MOVE THE TRAILER WHILE THE LEVELING JACKS ARE STILL IN CONTACT WITH THE GROUND OR IN THE EXTEND POSITION. THIS TRAILER IS EQUIPPED WITH STRAIGHT-ACTING JACKS. MOVING THE TRAILER WITH THE LEVELING JACKS EXTENDED CAN CAUSE SEVERE DAMAGE TO THE JACKS AND OR THE TRAILER AND CREATE A DRIVING HAZARD. DO NOT RELY SOLELY UPON WARNING LIGHTS. IT IS THE OPERATOR'S RESPONSIBILITY TO CHECK THAT ALL JACKS ARE FULLY RETRACTED INTO THE STORE/TRAVEL POSITION.

2. Turn the HWH master power switch off before traveling.

3. The trailer can be moved as soon as the red warning lights are out, the jacks are in the STORE/TRAVEL position and the green "TRAVEL MODE" light is on.



---

# OPERATING PROCEDURES

---

## MANUAL LEVELING

Trailer must be unhitched from the tow vehicle before leveling. The HWH front jacks may be used to lift the trailer for unhitching. If auxiliary jacks are used to unhitch the trailer, extend the HWH front jacks to the ground and retract the auxiliary jacks before the leveling system is used for leveling.

**NOTE: Refer to the trailer manufacturer owner's manual for unhitching.**

If parking on soft ground or asphalt paving, a wood block or pad should be placed under each jack.

**IMPORTANT: Overheating and excessive current drain will result if raise arrows are operated for an extended period of time.**

1. Turn the HWH master key switch on.

**NOTE: Each set of UP and DOWN ARROWS extend or retract one jack. If it is recommended to operate jacks in pairs while leveling the vehicle.**

2. Use the front UP arrow buttons or the two switch remote panel to extend the front jacks and unhitch the trailer.

3. A lit yellow LEVEL light indicates that the side, end or corner of the trailer is low. **If the rear yellow level light is on, it is recommended to push both front down arrows until the rear yellow light goes out.** Use UP ARROW buttons corresponding to lit yellow LEVEL lights to extend jacks as needed to put out all the yellow lights. Always give a front or rear yellow level light priority when leveling the trailer. If the ground is too uneven, the jacks may not have enough stroke to level the trailer. The trailer may have to be moved.

**NOTE: No matter what type of jacks the trailer is equipped with, the pump will always run when an UP (raise) arrow is pushed.**

**The pump will run when pushing any DOWN (lower) arrow if the trailer has (4) Double - Acting jacks.**

**If the trailer has (2) Double - Acting and (2) Single - Acting jacks, the pump will only run if the front DOWN (lower) arrow is pushed.**

4. After the trailer is level, the jacks not used for leveling may be extended until they touch the ground. This provides additional stability against wind and activity in the trailer. Jacks used to stabilize the trailer should lift the trailer about 3/4 inch.

5. Turn the HWH master power switch off.

# OPERATING PROCEDURES

## AUXILIARY PUMP RUN SWITCH OPERATION

**WARNING:** KEEP AWAY FROM WHEELS, DO NOT CRAWL UNDER THE VEHICLE, KEEP A SAFE DISTANCE IN FRONT AND REAR OF THE VEHICLE. THE VEHICLE MAY DROP AND / OR MOVE FORWARD OR BACKWARD WITHOUT WARNING AS THE VALVE RELEASE IS OPERATED.

### EXTEND JACKS OR ROOMS

**NOTE:** It is best if jacks are extended in pairs; both front, both rear, right front & right rear or left front & left rear. Only try to extend one room or step mechanism at a time.

1. Use the hydraulic connection diagrams to locate the appropriate valve(s) to extend the desired jack(s), room or step.
2. Locate the pump run switch on the power unit assembly.
3. Move the valve release cam(s) to the "VALVE OPEN" position.
4. Push the pump run toggle switch to the "RUN" position. Hold the toggle switch to "RUN" until the equipment is in the desired position.
5. Move the valve release cam(s) to the "VALVE CLOSED" position and release the the pump run toggle switch.

**NOTE:** If the pump toggle switch is released before closing a valve when extending a jack, the vehicle will drop until the valve is closed.

**IMPORTANT:** RELEASE CAM MIGHT BE ROTATED TO ANY DIRECTION ON THE VALVE. MAKE SURE TO MOVE THE RELEASE CAMS IN THE CORRECT DIRECTION. INCORRECT MOVEMENT OF THE CAMS CAN DAMAGE THE VALVES.

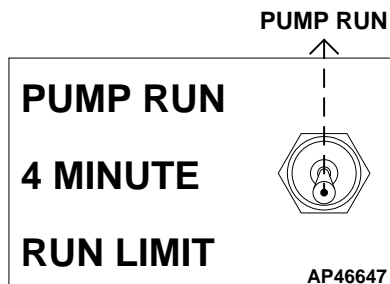

**IMPORTANT:** DO NOT hold the pump toggle switch to "PUMP RUN" for more than 4 minutes without allowing the pump motor to cool.

### RETRACTING POWER - EXTEND / POWER - RETRACT JACKS ROOMS OR STEPS

**IMPORTANT:** POWER - EXTEND / SPRING - RETRACT JACKS (SINGLE ACTING CYLINDERS) CAN NOT BE RETRACTED WHEN THE PUMP IS RUNNING.

**WARNING:** DO NOT CRAWL UNDER THE VEHICLE TO OPEN JACK MANIFOLD VALVES. ALLOW AMPLE ROOM FOR THE VEHICLE TO MOVE IN ANY DIRECTION WHEN A JACK MANIFOLD VALVE IS OPENED. OPEN THE VALVE RELEASE CAMS SLOWLY TO KEEP THE VEHICLE FROM DROPPING RAPIDLY.

1. Use the hydraulic connection diagrams to locate the appropriate valve(s) to retract the desired jack(s), room or step.
2. Locate the pump run switch on the power unit assembly.
3. Move the valve release cam(s) to the "VALVE OPEN" position.

**IMPORTANT:** WHEN RETRACTING JACKS, THE VEHICLE WILL START TO DROP AS SOON AS A JACK VALVE IS OPENED.

4. Push the pump run toggle switch to the "RUN" position. Hold the toggle switch to "RUN" until the equipment is fully retracted.
5. Move the valve release cam(s) to the "VALVE CLOSED" position and release the the pump run toggle switch.

**NOTE:** WHEN RETRACTING JACKS - Start with the front jacks. Alternate between the left and right jack several times, partially opening the jack valve slowly. This will allow the jacks to retract slightly each time, until the weight of the vehicle is off the jacks. This will reduce the possibility of twisting the vehicle. With the weight of the vehicle off the front jacks, open the front jack valves and use the pump run toggle switch. When both front jacks completely retracted, repeat the process with the rear jacks.

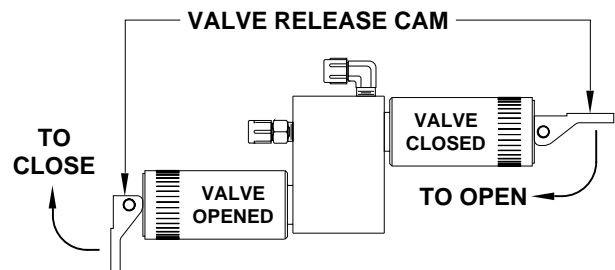

# OPERATING PROCEDURES

## AUXILIARY HAND PUMP OPERATION

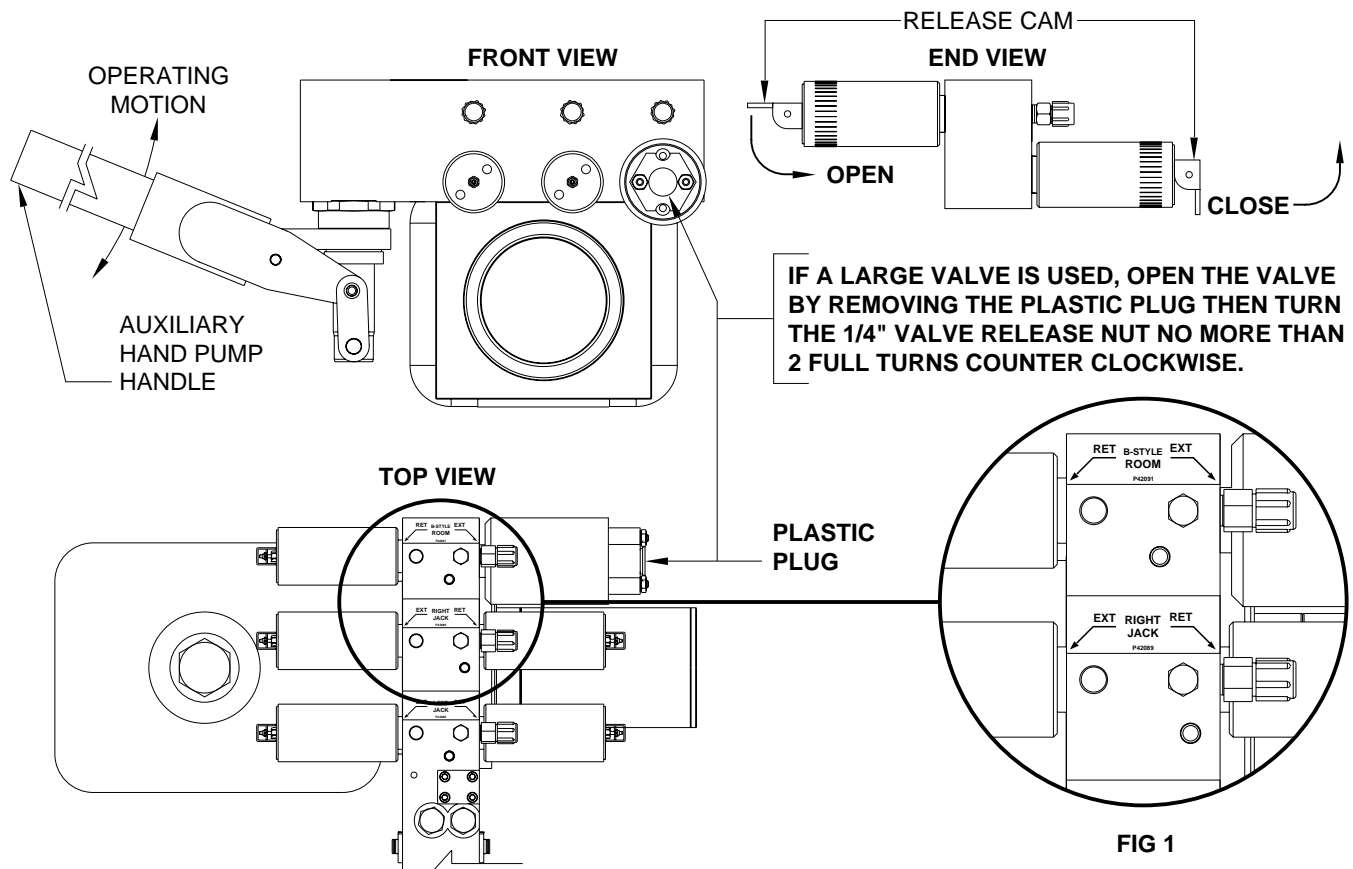

FIG 1

**NOTE:** Each hydraulic function requires a pair of solenoid valves one each for the extend and retract procedures. The number of functions and the items controlled by each pair of solenoid valves will vary for each system. The diagrams shown on this page represent a (3) function system of (2) jacks and (1) room as indicated by the labels shown in FIG 1. Use the labels specific to your system when following these procedures. Room control solenoid valves may be located at the synchronizing cylinder, not on the pump manifold.

The auxiliary hand pump can be used to extend or retract the landing gear, jacks or room extensions anytime the pump will not function.

The auxiliary hand pump is a two stage pump that will produce enough pressure to extend the landing gear and lift the vehicle as well as retract the landing gear. When operating the auxiliary pump to lift the vehicle or when the jacks are fully retracted, the pump handle will seem to "snap" as the pump goes to the second stage. The pumping action will be easier at first as the second stage starts to create more pressure.

**NOTE:** The hand pump will swivel to any position which will ease the operation of the hand pump.

To operate the auxiliary hand pump, open the appropriate solenoid valve. Insert the hand pump handle into the handle receptacle and move the handle in an up and down motion.

**NOTE:** If a room cannot be retracted using the auxiliary hand pump, see "MANUAL ROOM RETRACTION PROCEDURES".

**WARNING:** THE VEHICLE SHOULD BE SUPPORTED BY AUXILIARY STANDS OR SECURELY HITTED TO THE TOW VEHICLE BEFORE OPENING ANY VALVES.

The auxiliary hand pump may work easier if only one valve is open at a time. **Be careful to not twist the vehicle if only one solenoid valve is open.**

**IMPORTANT:** FOLLOW THE "SET UP" AND "PREPARATION FOR TRAVEL" PROCEDURES WHEN USING THE AUXILIARY HAND PUMP.

It is recommended to operate the auxiliary hand pump occasionally to check its operation.

**IMPORTANT:** ONLY MOVE THE RELEASE CAM IN THE DIRECTION SHOWN. MOVING THE CAM IN THE OPPOSITE DIRECTION CAN DAMAGE THE VALVES.

---

# MAINTENANCE

---

## OIL LEVEL

It is important that the four leveling units are fully retracted before checking the hydraulic oil level. To check the oil supply, remove the breather cap from the top of the hydraulic oil reservoir. The oil level should be approximately one inch below the top of the reservoir when adequately filled.

**FLUID:** HWH Specialty Hydraulic Oil is recommended. In an emergency Dexron automatic transmission fluid can be used.

**NOTE:** Dexron automatic transmission fluid contains red dye and can cause staining should a leak occur. **DO NOT USE** brake fluid or hydraulic jack fluid. Use of these can damage seals.

## UNUSUAL CONDITIONS

In general, to insure the smooth operation of the leveling system, it is a good idea to occasionally check the individual leveling units to prevent problems. This is especially true under the unusual conditions stated in the following:

If driving conditions are unusually muddy, the units may become caked or clogged with mud. This condition may hamper the proper operation of the leveling system. This problem may be prevented or remedied by cleaning off each leveling unit if they become excessively muddy.

In wet or icy weather leveling units may become encrusted with ice. This may cause the leveling system to function improperly. To eliminate this problem, periodically check the leveling units and break loose any ice which may be causing improper operation.

Do not move the trailer while the leveling units are still in contact with the ground. Visually check to see if the leveling units have returned to the STORE/TRAVEL position before moving the trailer.

**NOTE:** All major components of the system can be replaced with rebuilt units or can be sent to HWH CORPORATION to be rebuilt, when the system is out of warranty.

**WINTER WEATHER DRIVING:** Due to chemicals now used on highways in the winter, leveling system components should be washed with soap and water as soon as possible when traveling in winter conditions.

## JACK PRESSURE SWITCH ADJUSTMENT

The jack pressure switches are used to make sure the trailer is properly stabilized after the leveling process is complete.

The switches are adjustable. If set too high, the trailer will be lifted too high. If the switches are set too low the jacks may not come all the way down and lift as necessary.

The jacks should lift the trailer slightly when stabilizing, approximately 1/2".

The trailer should be completely loaded especially at the front when checking the switches.

Before adjusting the switch, unplug the switch so the wire is not twisted. Loosen the locking nut. Turn the threaded adjustment clockwise to increase pressure or counter-clockwise to decrease pressure. Use no more than a half turn before checking the system. Remember to tighten the locking nut when finished.

## WINTER WEATHER DRIVING

Anti-icing / deicing agents when splashed on your vehicle, continue to absorb moisture from the air even after they have dried. This can facilitate corrosion of metallic components, such as HWH jacks.

To help reduce the corrosion of jacks after exposure to anti-icing / deicing agents, thoroughly wash jacks with warm soapy water.

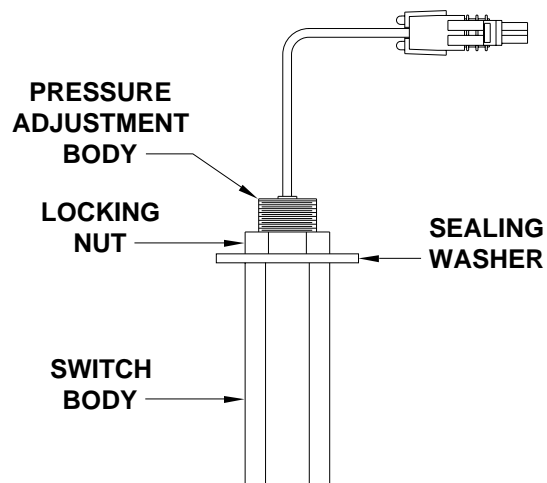

# MAINTENANCE

## PRIMING THE HAND PUMP

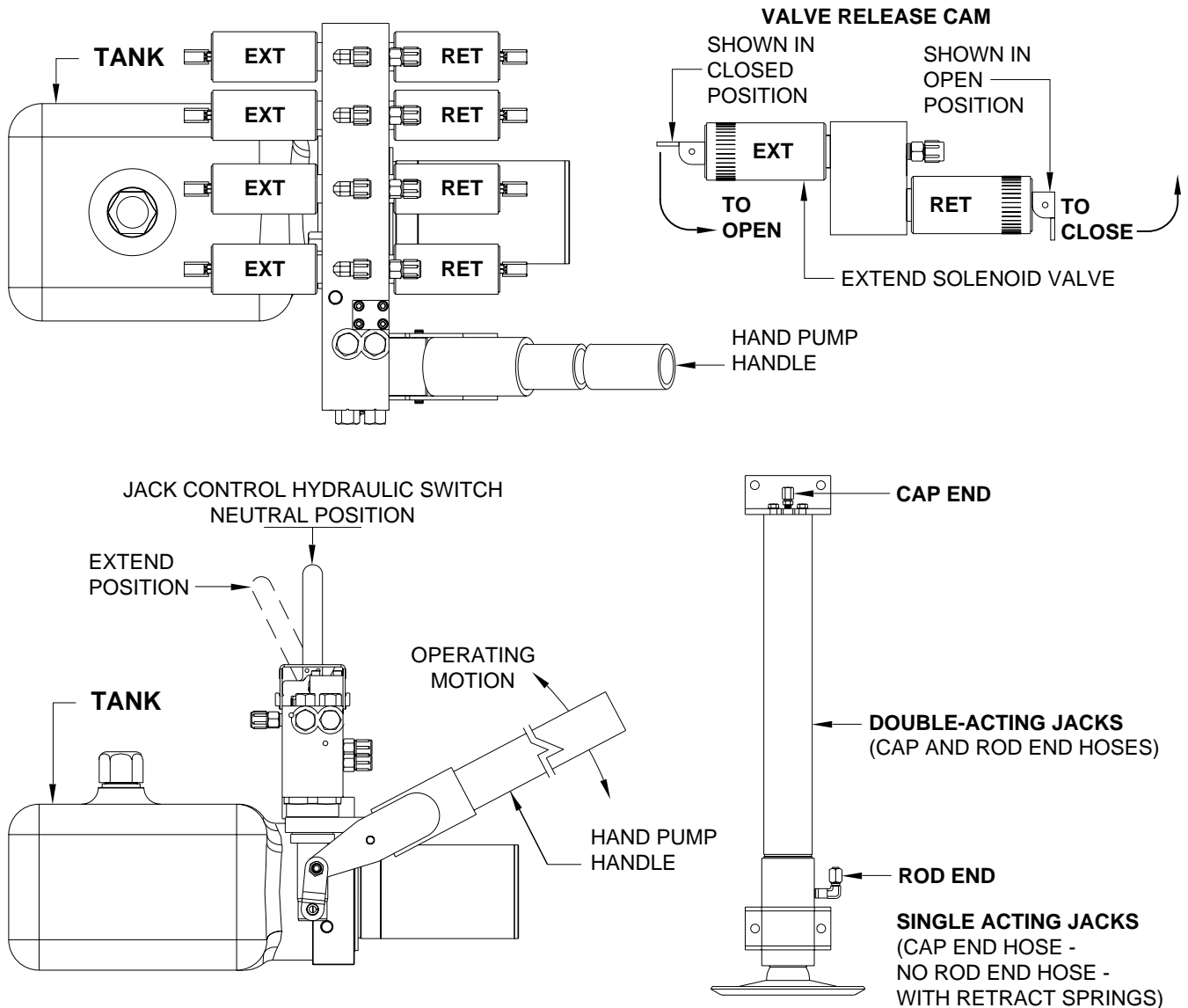

To prime the hand pump, it will be necessary to remove a hose from one of the jacks. One of the front jacks would be best, but use the easiest hose to get to.

If the system has Double-Acting cylinders on the front, remove the rod end hose from either of the front jacks. Place the end of the hose in a bucket. Make sure the tank is at least half full. Pump the hand pump until a healthy flow of oil is coming from the hose.

**IMPORTANT: DO NOT ALLOW THE FLUID LEVEL IN THE TANK TO LOWER MORE THAN 1 INCH BEFORE ADDING FLUID.**

Reattach the hose and retry the hand pump. Repeat the procedure if the hand pump does not move the jacks.

If the system has only Single-Acting jacks with return springs, remove the easiest hose to access and place the end in a bucket. Using the release cam, manually open the EXTEND solenoid valve for that jack (if equipped with solenoid valves) or move the jack control hydraulic switch to "EXTEND" for that jack. Make sure the tank is at least half full. Pump the hand pump until a healthy flow of fluid comes from the hose.

**IMPORTANT: DO NOT ALLOW THE FLUID LEVEL IN THE TANK TO LOWER MORE THAN 1 INCH BEFORE ADDING FLUID.**

Reattach the hose and retry the hand pump. Repeat the procedure if the hand pump does not move the jacks.

# INSTRUCTION SHEET

## SENSING UNIT MAINTENANCE/SERVICE

### REMOTE MOUNTED "POTTED" ELECTRONIC SENSING UNIT

## SENSING UNIT ACCURACY TOLERANCE

The sensing unit has an accuracy tolerance of  $\pm 5.4$  inches front to rear and  $\pm 1$  inch side to side on a 36 foot vehicle. Typical leveling results will be better.

## SENSING UNIT ADJUSTMENT / WITH ADJUSTING ENHANCEMENT

Level the vehicle by placing a bubble level in the center of the freezer floor or upon whichever surface within the vehicle that is to be level. It is best if the level is placed close to the mounting area of the sensing unit. Using the Leveling System and the bubble level, ignoring the yellow LEVEL lights on the Touch Panel, level the vehicle until the bubble is centered.

With the vehicle level according to the bubble level, if there are no yellow lights lit on the Touch Panel, the sensing unit is properly adjusted. If there are yellow LEVEL lights lit on the Touch Panel, manual adjustments to the Sensing Unit are needed.

The ignition (motorized units) or master power switch (towable units) must be on. Remove the "Adjusting Enhancement Cap". **DO NOT LOSE THIS CAP.** There is a small pin beneath the cap. Use a jumper wire with an alligator clip to apply a ground to the pin. This will make the sensing unit very sensitive. The yellow lights may "jump" around while adjusting the sensing unit. Let the lights settle down after each adjustment. Small, gentle turns will work best. Turn mounting screws 1 and 3 to adjust the sensing unit. Turn screws as instructed to turn out all the yellow LEDs. When all the LEDs are out, remove the jumper wire and replace the adjusting enhancement cap. **DO NOT** over tighten.

Move the vehicle to an unlevel position and level the vehicle according to the yellow level sensing lights on the touch panel. Readjust if necessary.

**IMPORTANT: THE SENSING UNIT MOUNTING SPRINGS SHOULD BE COMPRESSED ABOUT 1/2 THEIR FREE LENGTH. SCREW NUMBER 2 SHOULD NOT BE TURNED WHILE ADJUSTING THE SENSING UNIT. AFTER ADJUSTING THE SENSING UNIT, BUMP THE SENSING UNIT TO SEE THAT IT IS SETTLED TIGHT AGAINST ALL THREE SCREW HEADS AND STILL INDICATES THAT THE UNIT IS LEVEL.**

**NOTE: If opposing LED's are lit, there is a problem with the Sensing Unit.**

**If LED (A) is lit: Tighten adjustment screw number 1 until the LED is off.**

**If LED (C) is lit: Loosen adjustment screw number 1 until the LED is off.**

**If LED (B) is lit: Loosen adjustment screw number 3 until the LED is off.**

**If LED (D) is lit: Tighten adjustment screw number 3 until the LED is off.**

