



OPERATOR'S MANUAL

HWH® 725 Series, Computer-Controlled Hydraulic Leveling System For Trailers

FEATURING:

*Touch Panel Leveling Control
BI-AXIS® Hydraulic Leveling
Four Single - Acting Jacks
Auxiliary Hand Pump
Four Spacemaker® Rail Slideouts*

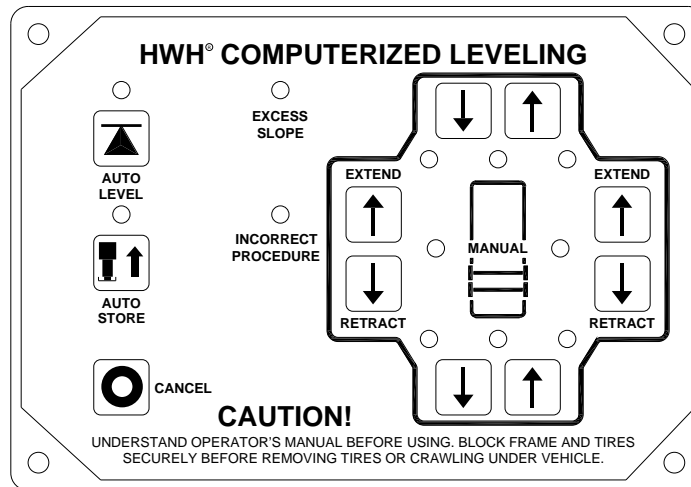

HWH CORPORATION

(On I-80, Exit 267 South)

2096 Moscow Road | Moscow, Iowa 52760

Ph: 800/321-3494 (or) 563/724-3396 | Fax: 563/724-3408

www.hwh.com

OPERATOR'S MANUAL

WARNING !

READ THE ENTIRE OPERATOR'S MANUAL BEFORE OPERATING.

BLOCK FRAME AND TIRES SECURELY BEFORE CRAWLING UNDER VEHICLE. DO NOT USE LEVELING JACKS OR AIR SUSPENSION TO SUPPORT VEHICLE WHILE UNDER VEHICLE OR CHANGING TIRES. VEHICLE MAY DROP AND/OR MOVE FORWARD OR BACKWARD WITHOUT WARNING CAUSING INJURY OR DEATH.

KEEP ALL PEOPLE CLEAR OF VEHICLE WHILE LEVELING SYSTEM IS IN USE.

WHILE HITCHING OR UNHITCHING, AVOID AREAS WHERE BODY MAY BE CRUSHED BY SUDDEN DROPPING OR SLIDING OF THE TRAILER.

DO NOT LIFT TOW VEHICLE WITH LEVELING SYSTEM.

NEVER PLACE HANDS OR OTHER PARTS OF THE BODY NEAR HYDRAULIC LEAKS. OIL MAY PENETRATE SKIN CAUSING INJURY OR DEATH.

WEAR SAFETY GLASSES WHEN INSPECTING OR SERVICING THE SYSTEM TO PROTECT EYES FROM DIRT, METAL CHIPS, OIL LEAKS, ETC. FOLLOW ALL OTHER APPLICABLE SHOP SAFETY PRACTICES.

IMPORTANT: IF VEHICLE IS EQUIPPED WITH A ROOM EXTENSION, READ ROOM EXTENSION SECTION BEFORE OPERATING LEVELING SYSTEM.

HOW TO OBTAIN WARRANTY SERVICE

THIS IS NOT TO BE INTERPRETED AS A STATEMENT OF WARRANTY

HWH CORPORATION strives to maintain the highest level of customer satisfaction. Therefore, if you discover a defect or problem, please do the following:

FIRST: Notify the dealership where you purchased the vehicle or had the leveling system installed. Dealership management people are in the best position to resolve the problem quickly. If the dealer has difficulty solving the problem, he should immediately contact the Customer Service Department, at HWH CORPORATION.

SECOND: If your dealer cannot or will not solve the problem, notify the Customer Service Department:
HWH CORPORATION 2096 Moscow Rd. Moscow IA. 52760
(563) 724-3396 OR (800) 321-3494. Give your name and address, coach manufacturer and model year, date the coach was purchased, or the date of system installation,

description of the problem, and where you can be reached during business hours (8:00 a.m. till 5:00 p.m. c.s.t.). HWH CORPORATION personnel will contact you to determine whether or not your claim is valid. If it is, HWH CORPORATION will authorize repair or replacement of the defective part, either by appointment at the factory or by the authorization of an independent service facility, to be determined by HWH CORPORATION. All warranty repairs must be performed by an independent service facility authorized by HWH CORPORATION, or at the HWH CORPORATION factory, unless prior written approval has been obtained from proper HWH CORPORATION personnel.

CONTROL IDENTIFICATION

625/2000 SERIES LEVELING SYSTEM

COMPUTER-CONTROL

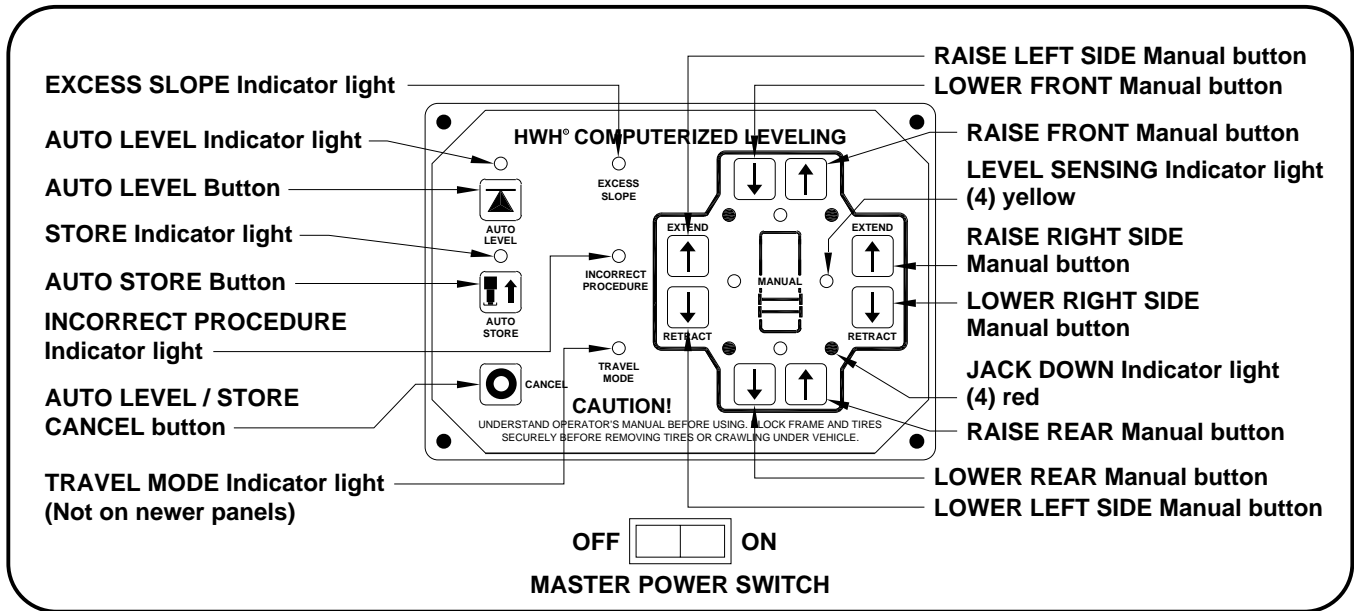

CONTROL FUNCTIONS

CONTROL BUTTONS

ON/AUTO (▲) BUTTON: This is the on button and automatic operation button. The on indicator light is above the (I) button.

"CANCEL" BUTTON: Push the "CANCEL" button to stop automatic hydraulic operation.

"STORE" BUTTON: The store indicator light is above the "AUTO STORE" button. This button is used to automatically retract the jacks.

EXTEND BUTTONS (UP ARROWS): These buttons will extend the jacks to lift the vehicle.

RETRACT BUTTONS (DOWN ARROWS): These buttons will retract the jacks to lower the vehicle.

SEE MANUAL LEVELING PROCEDURE.

MASTER POWER SWITCH: This switch controls power to the leveling system.

INDICATOR LIGHTS

HYDRAULIC OPERATIONS (▲) LIGHT: This light indicates that the panel is active.

INCORRECT OPERATION LIGHT: This light indicates an incorrect operation that cancels automatic leveling or store procedures.

STORE LIGHT: This light indicates that the system is in STORE mode.

"TRAVEL MODE" LIGHT: This LED, if present, has no function.

LEVELING LIGHTS: The four yellow indicating lights are level sensing indicators. When a yellow light is on, it indicates that its side, end, or corner of the vehicle is low. No more than two lights should be on at the same time.

JACK DOWN LIGHTS: The four red lights surrounding the yellow level indicators are jacks down WARNING lights. They are functional when the Master Power switch is on. When a jack is extended 1/4 to 1/2 inch, it's warning light will come on.

CONTROL IDENTIFICATION

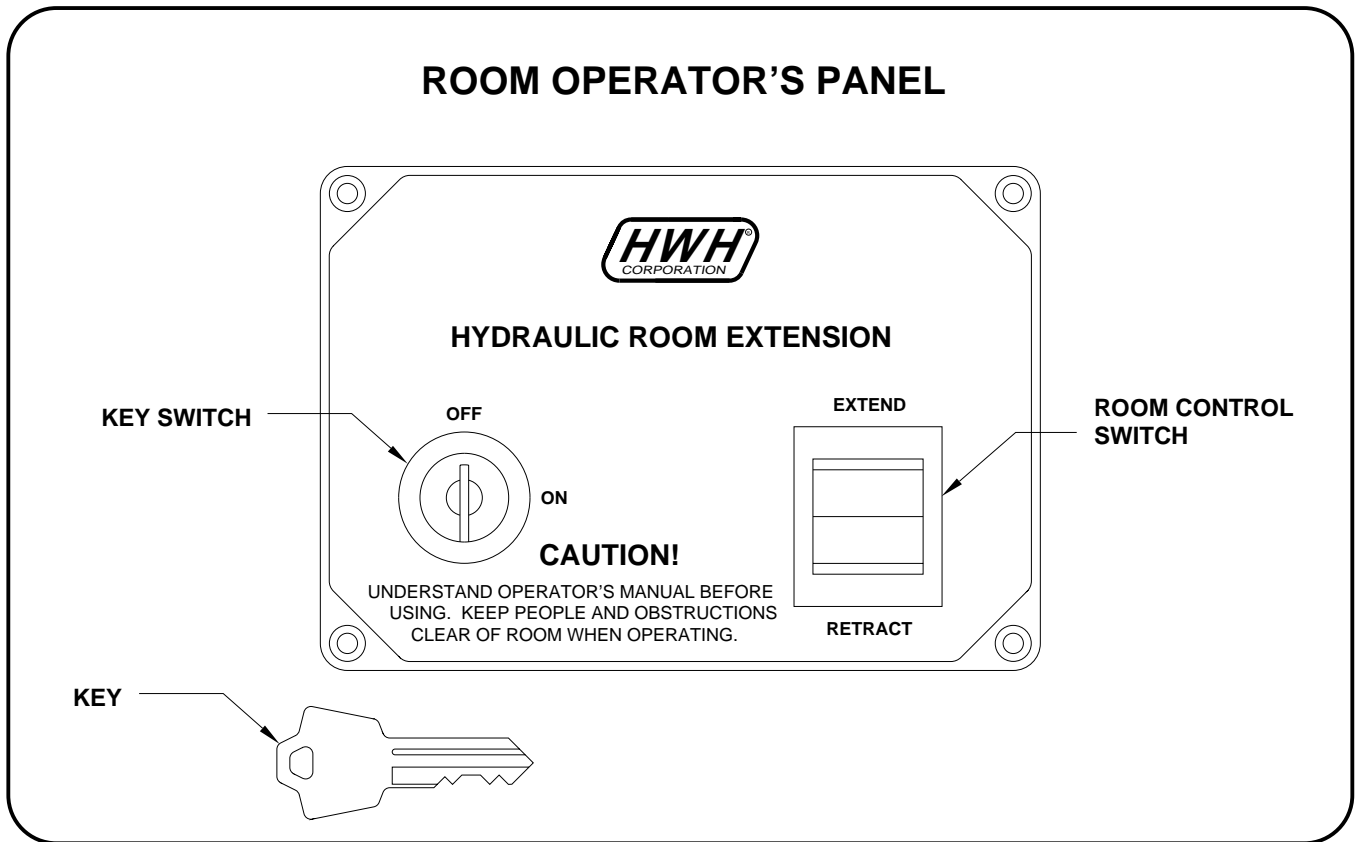

CONTROL FUNCTIONS

KEY SWITCH: The KEY SWITCH controls power to the ROOM CONTROL SWITCH. When the KEY SWITCH is in the "ON" POSITION the room can be operated, and the key cannot be removed. When the KEY SWITCH is in the "OFF" position the room cannot be operated, and the key can be removed.

ROOM CONTROL SWITCH: The ROOM CONTROL SWITCH is a two position momentary switch. Pressing the switch in the EXTEND POSITION will extend the room. Pressing the switch in the RETRACT POSITION will retract the room. Releasing the ROOM CONTROL SWITCH will halt the operation of the room.

Note: Some panels may have two room control rocker switches or one room control rocker switch and one room select rocker switch.

ROOM CONTROL SWITCH

(FOR VEHICLES WITHOUT THE HWH ROOM CONTROL PANEL)

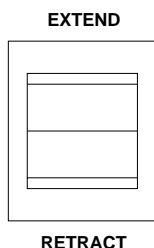

The ROOM CONTROL SWITCH is a two position momentary switch. Pressing the switch in the EXTEND POSITION will extend the room. Pressing the switch in the RETRACT POSITION will retract the room. Releasing the ROOM CONTROL SWITCH will halt the operation of the room.

CONTROL IDENTIFICATION

PUMP RUN TIME

PUMP RUN TIME

Pump motors used with HWH leveling systems and room extension systems come in 3 different diameters; 3", 3.7" and 4.5". Contact the vehicle manufacturer or HWH for help with identifying the motor size. **It is important that any time the pump runs for more than three minutes with a 3" motor; or six minutes with a 3.7" or 4.5" motor that the motor is allowed to cool for thirty minutes before continuing. Continuous operation of the pump motor without allowing the motor to cool can damage the motor.** For cold weather information see "COLD WEATHER OPERATIONS" below.

The HWH systems with a computer processor monitor the pump run time and will turn the pump off if the run time exceeds a specified time. This time can vary with different systems. Due to available electronics or system design, the pump run time programs will also vary. Leveling systems and room extensions that are not controlled by a system processor have no pump run time protection. **DO NOT run the pump more than three or six minutes without allowing the pump motor to cool for thirty minutes.**

SYSTEM VARIATIONS FOR PUMP RUN TIME

Some systems with rooms run the rooms separate from the system processor. These systems do not monitor pump run time when operating the rooms. **DO NOT run the pump more than three or six minutes without allowing the pump motor to cool for thirty minutes.**

Some systems can be turned back on immediately after the processor turns the pump off. **DO NOT turn the system back on or run the pump without allowing the pump motor to cool for thirty minutes.**

When operating some leveling systems manually or operating the room extensions, the pump will turn off and back on while pushing the control button when the pump run time has been exceeded. **DO NOT continue without allowing the pump motor to cool for thirty minutes.**

With some systems, when the processor has turned the pump off because the run time has been exceeded, power to the HWH system must be turned off and back on before the system will operate. With motorized vehicles, turn the ignition off and back on. With non-motorized vehicles, turn the master power switch for the HWH system off and back on. **DO NOT continue without allowing the pump motor to cool for thirty minutes.**

Some HWH systems are equipped with a lighted reset switch. If the processor turns the pump off because the run time has been exceeded, the light in the reset switch will turn on. The system will not operate until the reset switch is pushed.

DO NOT continue without allowing the pump motor to cool for thirty minutes.

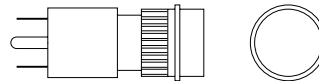

LIGHTED RESET SWITCH

No matter what HWH system is on the vehicle, the pump should not be ran for more than three minutes (3" motors) or six minutes (3.7" or 4.5" motors) without allowing the pump motor to cool for thirty minutes. Continuous operation of the pump motor without allowing the motor to cool can damage the pump motor.

Contact HWH corporation to get specific information about the system in this vehicle.

COLD WEATHER OPERATIONS

HWH leveling and room extension systems are designed to function in cold weather down to 0 degrees Fahrenheit. Below freezing (32 degrees Fahrenheit) the jacks or rooms will operate slower than usual.

For operation in temperatures dropping below -20 degrees Fahrenheit, it is necessary that the system is equipped with oil designed for extreme cold weather application such as a synthetic oil. (Contact HWH for recommendations.)

DO NOT run the pump motor continuously. It is important that any time the pump runs for more than three minutes with a 3" motor; or six minutes with a 3.7" or 4.5" motor that the motor is allowed to cool for thirty minutes before continuing. Continuous operation of the pump motor without allowing the motor to cool can damage the motor. Continuous operation of the pump with slow moving jacks or rooms in cold weather, without allowing the pump motor to cool will cause the pump motor to burn up and damage the pump assembly.

OPERATING PROCEDURES

GENERAL INSTRUCTIONS

Maintain adequate clearance in all directions for vehicle, room extensions, awnings, doors, steps, etc. Vehicle may move in any direction due to jacks extending or retracting, settling of the jacks or the vehicle, equipment malfunction, etc..

If parking on soft ground or asphalt paving, wood blocks or pads must be placed under the jacks.

Press the "CANCEL" button and turn the master power switch "OFF" at any time to stop the operation of the system.

WARNING: DO NOT MOVE THE VEHICLE IF ONE OR MORE JACKS ARE EXTENDED TO THE GROUND.

The HWH or OEM supplied master power switch must be on for the leveling system to operate.

PREPARATION FOR TRAVEL

Before traveling, the red jack warning lights must be off and the "TRAVEL MODE" light must be on. If lights are not correct for travel, retract jack as described in the JACK RETRACTION Section.

If the jacks are retracted but a red "WARNING" light is lit or the green "TRAVEL MODE" light is not lit, the system needs to be serviced.

NOTE: Newer panels may not have the "TRAVEL MODE" light.

Any room extension should be fully retracted before traveling.

WARNING: DO NOT MOVE THE VEHICLE WHILE THE LEVELING JACKS ARE STILL IN CONTACT WITH THE GROUND OR IN THE EXTEND POSITION. THIS

VEHICLE IS EQUIPPED WITH STRAIGHT-ACTING JACKS. MOVING THE VEHICLE WITH THE LEVELING JACKS EXTENDED CAN CAUSE SEVERE DAMAGE TO THE JACKS AND OR THE VEHICLE AND CREATE A DRIVING HAZARD. DO NOT RELY SOLELY UPON WARNING LIGHTS. IT IS THE OPERATOR'S RESPONSIBILITY TO CHECK THAT ALL JACKS ARE FULLY RETRACTED INTO THE STORE/TRAVEL POSITION.

Any time the "AUTO LEVEL" button has been pushed, push the "STORE" button before traveling.

If the jacks cannot be retracted according to the JACK RETRACTION Section, retract the jacks according to the MANUAL JACK RETRACTION Section. The system should then be checked.

ROOM EXTENSION PROCEDURES

IMPORTANT: If the vehicle is equipped with a room extension read this section carefully.

IMPORTANT: It is recommended to level and stabilize the vehicle before extending the room.

IMPORTANT: Extending or retracting any leveling jacks when the room is extended is not recommended.

Refer to the vehicle owner's manual for proper operation of room extensions.

IMPORTANT: Do not use a room extension support when the vehicle is supported by the leveling system.

OPERATING PROCEDURES

INCORRECT PROCEDURE LIGHT

NOTE: Early systems have a "NOT IN PARK/BAKE" light instead of an "INCORRECT PROCEDURE" light. These early systems will react to the situations noted in this section, but the "NOT IN PARK/BRAKE" will NOT turn on and the front warning lights will NOT flash.

There are several situations that prevent the "AUTO LEVEL" or "AUTO STORE" buttons from functioning or that will stop the auto leveling process. When these situations occur, the system turns the "INCORRECT PROCEDURE" light on steady and flashes the two front RED warning lights for 10 seconds. After 10 seconds the indicator lights will then return to their normal state. The "INCORRECT PROCEDURE" lights will go out. The front warning lights will remain on if the jacks are extended.

The following situations will turn the "INCORRECT PROCEDURE" light on and flash the front warning lights.

NOTE: No touch panel buttons will function while the "INCORRECT PROCEDURE" light is on.

1. The "AUTO LEVEL" button will not function unless at least one front jack is firmly on the ground supporting the weight of the trailer.
2. If the rear YELLOW level light is on, the "AUTO LEVEL" button will not function unless at least one front jack is firmly on the ground and both front warning lights are on steady.
3. If the front of the trailer is lowering during the auto level procedure and either front warning switch turns off, the system will shut down.
4. The "AUTO STORE" button will not function if either front jack is supporting any of the trailer weight or if either front jack pressure switch is on. If the vehicle is equipped with double - acting front jacks or landing gear, one or both front jack pressure switches may remain on if the front manual DOWN ARROW is not used to hitch the trailer to the tow vehicle even if both front jacks are not on the ground. If the "INCORRECT PROCEDURE" light flashes when the "STORE" button is pushed after the trailer is hitched to the tow vehicle, push the front DOWN ARROW button for several seconds then retry the "STORE" button.

OPERATING PROCEDURES

SET UP AND AUTOMATIC LEVELING PROCEDURE

Trailer must be unhitched from the tow vehicle before leveling. The HWH front jacks may be used to lift the trailer for unhitching. If auxiliary jacks are used to unhitch the trailer, extend the HWH front jacks to the ground and retract the auxiliary jacks before the leveling system is used for leveling.

NOTE: Refer to the trailer manufacturer owner's manual for unhitching.

If parking on soft ground or asphalt paving, a wood block or pad should be placed under each jack.

IMPORTANT: Overheating and excessive current drain will result if raise arrows are operated for an extended period of time.

1. Turn the HWH master power switch on.
2. Use the front UP arrow manual button to extend the front jacks to unhitch the trailer.

NOTE: Before unhitching the trailer, the operator may want to check the jacks and place pads under the jacks if the ground will not support the vehicle.

IMPORTANT: The "AUTO LEVEL" button will not function unless at least one front jack is firmly on the ground, supporting the weight of the trailer.

If the rear yellow level indicator is on, the "AUTO LEVEL" button will not function unless at least one front jack is firmly on the ground supporting the trailer and both front red warning lights are on.

If either of the above situations are encountered, the "INCORRECT PROCEDURE" light will come on steady for 10 seconds. Both front warning lights will flash while the "INCORRECT PROCEDURE" light is on. After 10 seconds, the "INCORRECT PROCEDURE" light will shut off and the front warning lights will stop flashing. When the situation has been corrected, the "AUTO LEVEL" button will function.

NOTE: No touch panel buttons will function while the "INCORRECT PROCEDURE" light is on.

3. Push the "AUTO LEVEL" button. The AUTO LEVEL light will flash and the auto leveling procedure will begin.

The system will automatically extend the jacks to level the vehicle and then extend any remaining jacks for stabilizing. The system will level the trailer front to rear (if needed) before leveling side to side. If the rear yellow level indicator is on, the system will lower the front of the trailer to level the trailer. If the front jacks are Double - Acting jacks, the pump will run while the front is lowering. After the system has finished leveling and stabilizing, it will automatically shut off.

During the stabilize portion of the auto leveling sequence, first the system will check the right rear jack pressure switch and extend the jack as necessary. If or when the right rear pressure switch is satisfied, the system checks the left rear jack pressure switch and extends the jack as necessary. If or when the left rear pressure switch is satisfied, the system will check both front jack pressure switches at the same time.

NOTE: The system will only lower the front of the trailer if the rear level light is on when the "AUTO LEVEL" button is pushed. If the rear light is not on or goes out while lowering the trailer, no lowering procedure is used after that no matter what level light may come on.

If either front red warning light goes out while the front is lowering, the system will discontinue the leveling procedure and shut off. The "INCORRECT PROCEDURE" light will come on with the two front warning lights blinking for 10 seconds.

EXCESS SLOPE SITUATION: In the event the jacks are unable to level the coach, the "EXCESS SLOPE" light will come on. Excess slope is two jacks fully extended without turning the yellow level light out. The system will not stabilize the vehicle if the "EXCESS SLOPE" light comes on. One or more jacks may be extended. The system will shut off leaving the "EXCESS SLOPE" light on. The "EXCESS SLOPE" light will remain on if there is power to the control box, until the jacks have been fully retracted using the "STORE" button, turning the red warning lights out. Refer to the HITCHING AND STORING JACKS section. Move the trailer to a more level position or level the trailer as close as possible according to the MANUAL LEVELING section. Manual leveling will operate when the EXCESS SLOPE light is on.

4. Make sure the HWH master power switch is off any time the touch panel is not active whether the jacks are extended or retracted.

OPERATING PROCEDURES

625/2000 SERIES LEVELING SYSTEM

HITCHING AND STORING JACKS

WARNING: THE OPERATOR MUST BE SURE THAT THERE ARE NO OBJECTS UNDER THE TRAILER AND THAT ALL PEOPLE ARE CLEAR OF THE TRAILER.

HITCHING

IMPORTANT: The "STORE" button will not function until the weight of the trailer is off the front jacks.

1. The HWH master switch must be on to hitch the trailer and store the jacks.

The manual UP (extend jacks) and DOWN (retract jacks) arrows will function anytime the master power switch is on if the "AUTO LEVEL" or AUTO STORE lights are not flashing.

2. Push the rear down arrow (RETRACT button) until the rear jack down warning lights are out.

3. NOTE: The rear jack must have ground clearance during the hitching procedure.

4. Hitch the trailer to the tow vehicle according to the manufacturers instructions. Use the existing landing gear or the front UP (EXTEND jacks) and DOWN (RETRACT jacks) arrows.

NOTE: If the trailer is equipped with an air suspension, it is recommended to not connect the tow vehicle air supply to the trailer until the trailer is hitched to the tow vehicle and the jacks are not touching the ground.

STORING JACKS

1. After the trailer is securely hitched to the tow vehicle, and the weight of the trailer is off of the front jacks, push the "STORE" button. All 4 jacks will retract.

NOTE: If the weight of the trailer is not removed from both front jacks, the "AUTO STORE" button will not function. If the "AUTO STORE" button is pushed, the "INCORRECT PROCEDURE" light will come on steady with the two front warning lights flashing for 10 seconds.

NOTE: No touch panel buttons will function while the "INCORRECT PROCEDURE" light is on.

The pump never runs during the auto store procedure. The system shuts off (1) minute after the last red warning light goes out. If any warning light remains on, the system will stay in the auto store mode for (20) minutes and then shut off.

WARNING: ONLY USE THE "STORE" BUTTON IF THE TRAILER IS HITCHED TO A TOW VEHICLE OR SECURELY SUPPORTED BY THE EXISTING LANDING GEAR.

IMPORTANT: DO NOT interrupt power to the leveling system while the "STORE" indicator light is blinking. DO NOT push the "OFF" button or turn power off to the system. The system must be allowed to completely finish the STORE mode.

WARNING: DO NOT MOVE THE TRAILER WHILE THE LEVELING JACKS ARE STILL IN CONTACT WITH THE GROUND OR IN THE EXTEND POSITION. THIS TRAILER IS EQUIPPED WITH STRAIGHT-ACTING JACKS. MOVING THE TRAILER WITH THE LEVELING JACKS EXTENDED CAN CAUSE SEVERE DAMAGE TO THE JACKS AND OR THE TRAILER AND CREATE A DRIVING HAZARD. DO NOT RELY SOLELY UPON WARNING LIGHTS. IT IS THE OPERATOR'S RESPONSIBILITY TO CHECK THAT ALL JACKS ARE FULLY RETRACTED INTO THE STORE/TRAVEL POSITION.

2. Turn the HWH master power switch off before traveling.

3. The trailer can be moved as soon as the red warning lights are out, the jacks are in the STORE/TRAVEL position and the green "TRAVEL MODE" light is on.

OPERATING PROCEDURES

MANUAL LEVELING

Trailer must be unhitched from the tow vehicle before leveling. The HWH front jacks may be used to lift the trailer for unhitching. If auxiliary jacks are used to unhitch the trailer, extend the HWH front jacks to the ground and retract the auxiliary jacks before the leveling system is used for leveling.

NOTE: Refer to the trailer manufacturer owner's manual for unhitching.

If parking on soft ground or asphalt paving, a wood block or pad should be placed under each jack.

IMPORTANT: Overheating and excessive current drain will result if raise arrows are operated for an extended period of time.

1. Turn the HWH master key switch on.
2. Use the front UP arrow buttons to extend the front jacks and unhitch the trailer.

NOTE: No touch panel buttons will function while the "INCORRECT PROCEDURE" light is on.

3. A lit yellow LEVEL light indicates that the side, end or corner of the trailer is low. **If the rear yellow level light is on, it is recommended to push the front down arrow until the rear yellow light goes out.** Pushing the up arrow for corresponding yellow level lights will extend that jack or jack pair to level the vehicle. Extend jacks as needed to put out all the yellow lights. Always give a front or rear yellow level light priority when leveling the trailer. If the ground is too uneven, the jacks may not have enough stroke to level the trailer. The trailer may have to be moved.

4. After the trailer is level, the jacks not used for leveling may be extended until they touch the ground. This provides additional stability against wind and activity in the trailer. Jacks used to stabilize the trailer should lift the trailer about 3/4 inch.

5. Turn the HWH master power switch off.

OPERATING PROCEDURES

ROOM EXTEND PROCEDURE

WARNING: OPERATING A ROOM WITH ANY ROOM LOCKING, CLAMPING OR MANUAL RETRACTING DEVICES ATTACHED OR ENGAGED CAN CAUSE PERSONAL INJURY AND VEHICLE DAMAGE. IT IS THE OPERATOR'S RESPONSIBILITY TO ENSURE THAT ALL ROOM LOCKING, CLAMPING OR MANUAL RETRACTING DEVICES ARE DETACHED OR DISENGAGED BEFORE OPERATING THE ROOM.

Refer to vehicle manufacturer for proper sequence of room extension and leveling system operation.

1. Unlock all room-locking devices to include travel clamps/locks supplied by manufacturers other than HWH.

NOTE: If a **MANUAL RETRACT WINCH** is attached to the room remove it before extending the room.

WARNING: KEEP PEOPLE AND OBSTRUCTIONS CLEAR OF ROOM WHEN OPERATING.

NOTE: Make sure there is adequate clearance to fully extend the room.

2. Turn the MASTER POWER SWITCH on if applicable.
3. Turn the room control panel KEY SWITCH to "ON".
4. To extend the room, press and hold the room control panel ROCKER SWITCH in the "EXTEND" position until the room is fully extended.

IMPORTANT: If the room extension is a level out room, hold the room control switch to the extend position until the room is fully extended and has dropped to the completely lowered position.

NOTE: Hold the switch to "EXTEND" three or four seconds after the room is fully extended. This assures proper pressurization of the cylinders. **During normal operation of the room, do not reverse direction of the room until the room is fully extended. If necessary, the direction of the room may be reversed, but watch for binding of the room. If the direction of the room has been reversed, DO NOT re-extend the room until the room has been fully retracted.**

IMPORTANT: Do not hold the ROOM CONTROL SWITCH in the "EXTEND" position for more than ten seconds after the room is fully extended (and down if applicable) or stops moving. **If either side of the room stops moving, release the room control switch immediately. DO NOT force the room. DO NOT reverse direction of the room, contact HWH Customer Service for assistance 1-800-321-3494.**

NOTE: Releasing the ROOM CONTROL SWITCH will halt the operation of the room.

IMPORTANT: Do not use a room extension support when the vehicle is supported by the leveling system.

5. Turn the KEY SWITCH and MASTER POWER SWITCH off.

OPERATING PROCEDURES

ROOM RETRACT PROCEDURE

WARNING: KEEP PEOPLE AND OBSTRUCTIONS CLEAR OF ROOM WHEN OPERATING.

Refer to vehicle manufacturer for proper sequence of room extension and leveling system operation.

1. Turn the MASTER POWER SWITCH on if applicable.
2. Turn the room control panel KEY SWITCH to "ON".
3. To retract the room press and hold the ROOM CONTROL ROCKER SWITCH in the "RETRACT" position until the room is fully retracted.

Important: if the room extension is a level-out room, the room must raise completely before it will retract. If the room will not raise, do not force the room. Refer to the MANUAL ROOM LIFT PROCEDURES page.

NOTE: Hold the switch to "RETRACT" three or four seconds after the room is fully retracted. This assures proper pressurization of the cylinders. **During normal operation of the room, do not reverse direction of the room until the room is fully retracted. If necessary, the direction of the room may be reversed, but watch for binding of the room. If the direction of the room has been reversed, DO NOT retract the room until the room has been fully extended.**

IMPORTANT: Do not hold the ROOM CONTROL SWITCH in the "RETRACT" position for more than ten seconds after the room is fully retracted or stops moving.

If either side of the room stops moving, release the room control switch immediately. DO NOT force the room. DO NOT reverse direction of the room, contact HWH Customer Service for assistance 1-800-321-3494.

NOTE: Releasing the ROOM CONTROL SWITCH will halt the operation of the room.

4. If the room will not retract see the MANUAL ROOM RETRACT PROCEDURE.

IMPORTANT: Room-locking devices should be locked while traveling.

5. Turn the room control panel KEY SWITCH and MASTER POWER SWITCH off.

MANUAL ROOM AND GENERATOR SLIDE RETRACT PROCEDURE

(USE ONLY WHEN THE ROOM WILL NOT RETRACT WITH THE ROOM CONTROL SWITCH)

SYNC CYLINDER WITH INTEGRATED SOLENOID VALVE MANIFOLD

OVERVIEW

The room can be retracted manually if a hydraulic or electric failure prevents the room from being retracted using the CONTROL SWITCH. For normal retract sequence see the ROOM SLIDE RETRACT PROCEDURES. Refer to the vehicle manufacturer for storage location of the retract device and information for connecting the device to the room.

IMPORTANT: If the vehicle is not equipped with a winch, DO NOT use other pulling devices to retract the room. Follow steps 2 and 3 and try pushing the room in. Contact the vehicle manufacturer or HWH Customer Service at 1-800-321-3494 or 563-724-3396 for assistance.

WARNING: A MANUAL RETRACT WINCH PROVIDED BY HWH IS EQUIPPED FOR MANUALLY RETRACTING THE ROOM ONLY. IT IS NOT TO BE USED FOR LIFTING OR ANY OTHER APPLICATION. HIGH FORCES ARE CREATED WHEN USING A WINCH, CREATING POTENTIAL SAFETY HAZARDS. FAILURE TO FOLLOW ALL WARNINGS AND INSTRUCTIONS MAY CAUSE FAILURE OF THE MANUAL RETRACT WINCH OR CONNECTIONS RESULTING IN DAMAGE OR PERSONAL INJURY. MAINTAIN A FIRM GRIP ON THE WINCH HANDLE AT ALL TIMES. NEVER RELEASE THE HANDLE WHEN RATCHET LEVER IS IN THE OFF POSITION AND THE WINCH IS LOADED. THE WINCH HANDLE COULD SPIN VIOLENTLY AND CAUSE PERSONAL INJURY. CHECK THE WINCH AND STRAPS FOR DAMAGE OR WEAR, AND CHECK FOR PROPER RATCHET OPERATION ON EACH USE OF THE WINCH. DO NOT USE IF DAMAGED OR WORN.

1. Retract jacks following the LEVELING SYSTEM RETRACT PROCEDURE.

NOTE : When manually retracting the room, it is recommended the jacks are retracted before retracting the room.

2. Locate the SYNCHRONIZING CYLINDER.

3. If vehicle is equipped with more than one room, determine which synchronizing cylinder controls the room. Manually open the valve release cams for the extend and retract solenoid valves by moving the valve release cam to the open position.

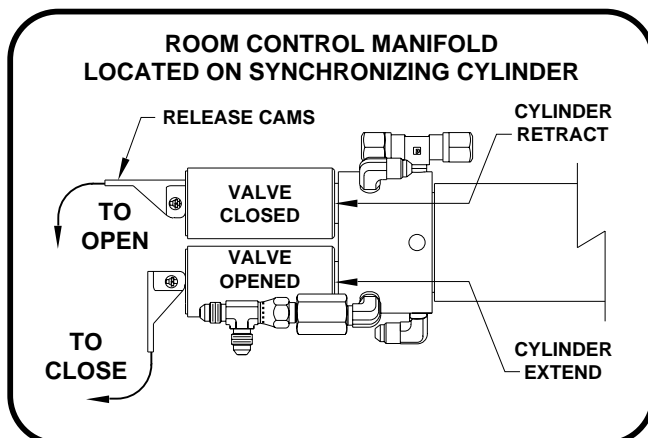

NOTE: The valve release cam might be rotated in any direction on the valve. Pushing the release cam in the wrong direction could damage the valve.

NOTE: The room may move slightly as the SOLENOID VALVES are opened and internal pressure is released.

4. Locate the MANUAL RETRACT DEVICE and connect it to the room according to the vehicle manufacturer's instructions. To extend a WINCH STRAP firmly grasp WINCH HANDLE, place RATCHET LEVER in its OFF position, and slowly rotate the WINCH HANDLE counter clockwise, keeping a firm grip on the handle. When enough WINCH STRAP is extended, place the RATCHET LEVER in its ON position and slowly rotate the WINCH HANDLE clockwise until the RATCHET LEVER locks.

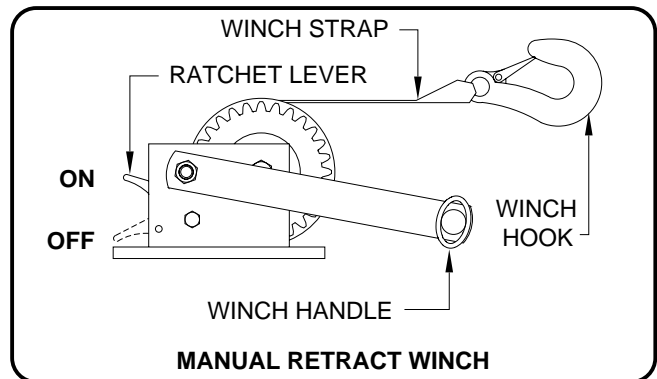

5. Slowly winch the room in by turning the WINCH HANDLE clockwise. The RATCHET LEVER should produce a loud, sharp, clicking noise.

NOTE: Winching the room in quickly will raise pressure in the hydraulic fluid and make winching more difficult.

WARNING: OPERATE THE MANUAL RETRACT WINCH BY HAND POWER ONLY. IF THE WINCH CANNOT BE CRANKED EASILY WITH ONE HAND IT IS PROBABLY OVERLOADED. IF WINCHING BECOMES TO DIFFICULT STOP AND CHECK FOR OBSTRUCTIONS/RESTRICTIONS ON THE ROOM AND ROOM EXTENSION MECHANISM.

6. When the room is fully retracted, engage any room locking devices. Leave the retract winch engaged and the solenoid valves open.

WARNING: THE ROOM EXTENSION SOLENOID VALVE RELEASE MUST BE IN THE OPEN POSITION WHEN A MANUAL RETRACT WINCH IS ENGAGED.

7. The system should be repaired before using again.

OPERATING PROCEDURES

AUXILIARY HAND PUMP OPERATION

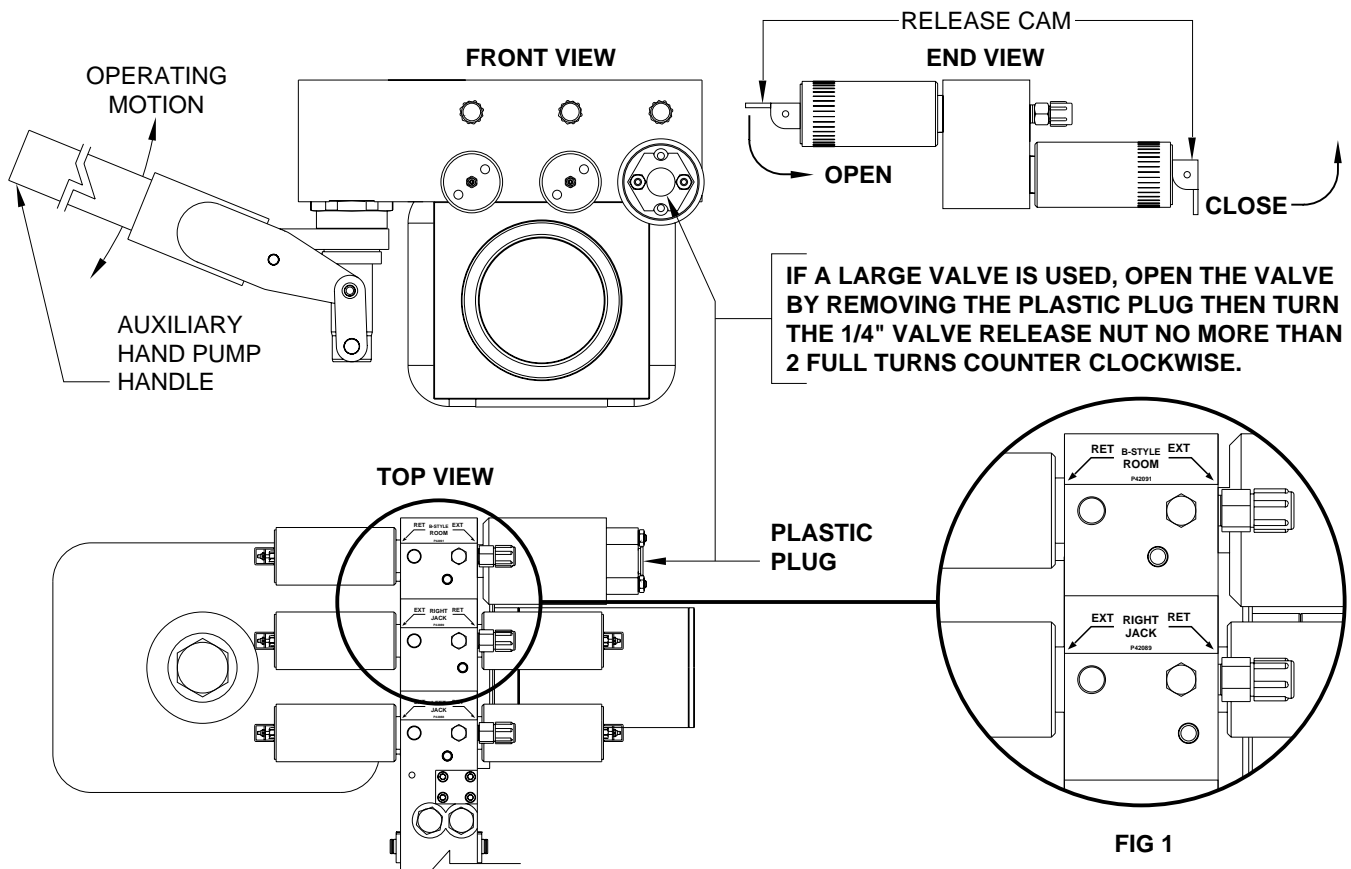

FIG 1

NOTE: Each hydraulic function requires a pair of solenoid valves one each for the extend and retract procedures. The number of functions and the items controlled by each pair of solenoid valves will vary for each system. The diagrams shown on this page represent a (3) function system of (2) jacks and (1) room as indicated by the labels shown in FIG 1. Use the labels specific to your system when following these procedures. Room control solenoid valves may be located at the synchronizing cylinder, not on the pump manifold.

The auxiliary hand pump can be used to extend or retract the landing gear, jacks or room extensions anytime the pump will not function.

The auxiliary hand pump is a two stage pump that will produce enough pressure to extend the landing gear and lift the vehicle as well as retract the landing gear. When operating the auxiliary pump to lift the vehicle or when the jacks are fully retracted, the pump handle will seem to "snap" as the pump goes to the second stage. The pumping action will be easier at first as the second stage starts to create more pressure.

NOTE: The hand pump will swivel to any position which will ease the operation of the hand pump.

To operate the auxiliary hand pump, open the appropriate solenoid valve. Insert the hand pump handle into the handle receptacle and move the handle in an up and down motion.

NOTE: If a room cannot be retracted using the auxiliary hand pump, see "MANUAL ROOM RETRACTION PROCEDURES".

WARNING: THE VEHICLE SHOULD BE SUPPORTED BY AUXILIARY STANDS OR SECURELY HITTED TO THE TOW VEHICLE BEFORE OPENING ANY VALVES.

The auxiliary hand pump may work easier if only one valve is open at a time. **Be careful to not twist the vehicle if only one solenoid valve is open.**

IMPORTANT: FOLLOW THE "SET UP" AND "PREPARATION FOR TRAVEL" PROCEDURES WHEN USING THE AUXILIARY HAND PUMP.

It is recommended to operate the auxiliary hand pump occasionally to check its operation.

IMPORTANT: ONLY MOVE THE RELEASE CAM IN THE DIRECTION SHOWN. MOVING THE CAM IN THE OPPOSITE DIRECTION CAN DAMAGE THE VALVES.

MAINTENANCE

PRIMING THE HAND PUMP

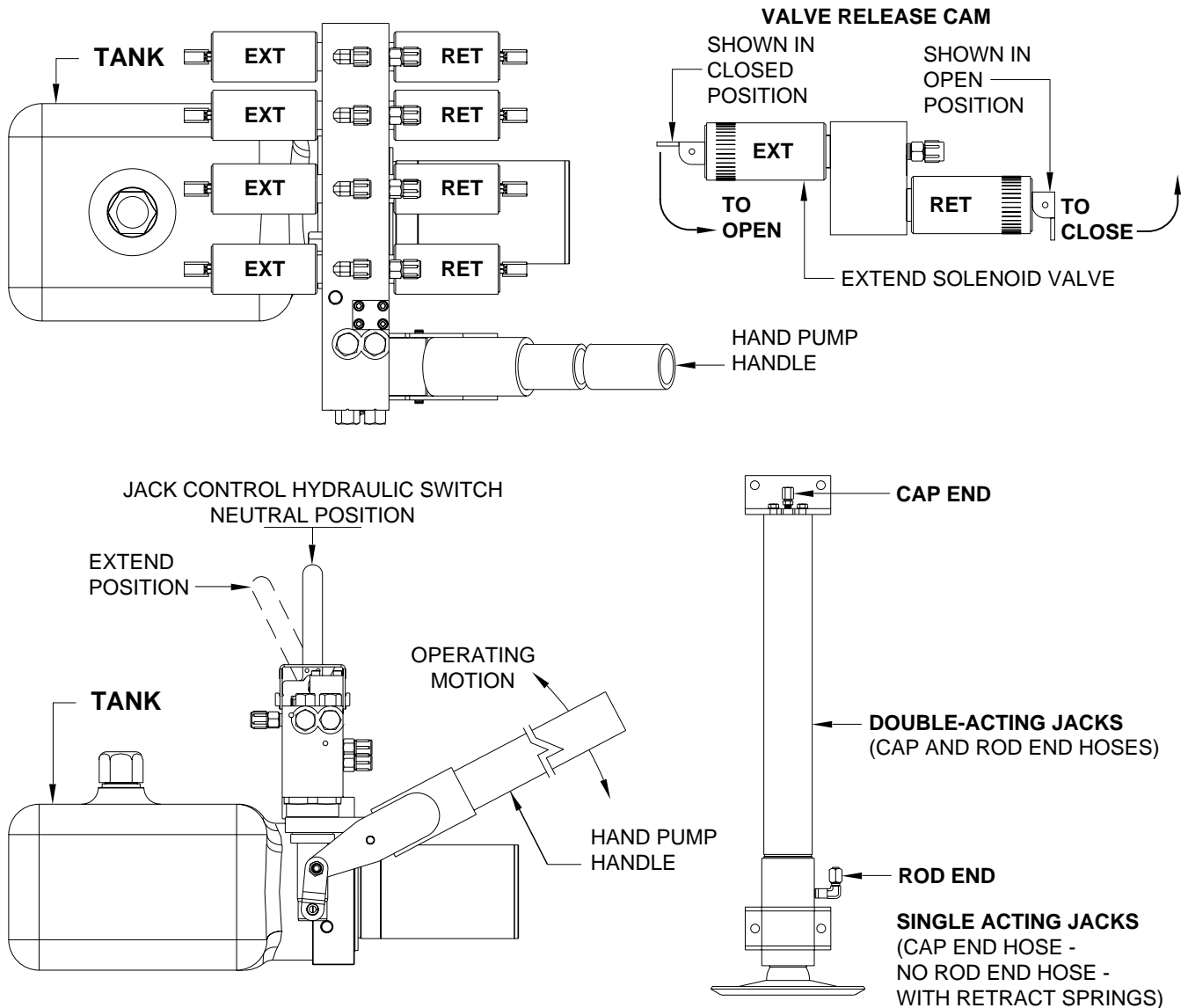

To prime the hand pump, it will be necessary to remove a hose from one of the jacks. One of the front jacks would be best, but use the easiest hose to get to.

If the system has Double-Acting cylinders on the front, remove the rod end hose from either of the front jacks. Place the end of the hose in a bucket. Make sure the tank is at least half full. Pump the hand pump until a healthy flow of oil is coming from the hose.

IMPORTANT: DO NOT ALLOW THE FLUID LEVEL IN THE TANK TO LOWER MORE THAN 1 INCH BEFORE ADDING FLUID.

Reattach the hose and retry the hand pump. Repeat the procedure if the hand pump does not move the jacks.

If the system has only Single-Acting jacks with return springs, remove the easiest hose to access and place the end in a bucket. Using the release cam, manually open the EXTEND solenoid valve for that jack (if equipped with solenoid valves) or move the jack control hydraulic switch to "EXTEND" for that jack. Make sure the tank is at least half full. Pump the hand pump until a healthy flow of fluid comes from the hose.

IMPORTANT: DO NOT ALLOW THE FLUID LEVEL IN THE TANK TO LOWER MORE THAN 1 INCH BEFORE ADDING FLUID.

Reattach the hose and retry the hand pump. Repeat the procedure if the hand pump does not move the jacks.

MAINTENANCE

OIL LEVEL

All maintenance should be done as part of the normal servicing of the coach.

The oil level should be checked when the vehicle is first purchased and then once every two years. More often if there is an oil leak in the system.

Any HWH hydraulic equipment, including jacks, slide-outs and steps should be fully retracted before checking fluid level. The oil reservoir is part of the pump / manifold assembly. The oil level is checked and filled through the breather cap. Clear any dirt away from the breather / filler cap before removing.

The oil level should be within one inch of the top of the reservoir. Most breather caps have a dipstick. Fluid level should be between the bottom of the dipstick and the center mark.

NOTE: Overfilling the tank can cause leakage of oil through the breather cap.

FLUID: HWH Specialty Hydraulic Oil is recommended. In an emergency Dexron automatic transmission fluid can be used. **NOTE:** Dexron automatic transmission fluid contains red dye and can cause staining should a leak occur. **DO NOT USE** brake fluid or hydraulic jack fluid. Use of these can damage seals.

ELECTRICAL SYSTEM

The batteries should be in good condition and fully charged. Weak batteries can cause erratic operation. Battery cable terminals and battery posts and connections should be kept clean.

All electrical connections, especially ground connections, should be clean, tight, free from corrosion and protected from weathering.

JACKS

There are very few user serviceable parts on the jacks. The jacks require very little maintenance. If the jacks are extremely dirty with caked on mud they should be washed.

If extremely dirty, the jack rods should NOT be wiped. The jack rods do not need to be oiled or sprayed with anything. See ML47149 for proper maintenance of all jacks.

ROOM EXTENSIONS

The HWH room mechanisms need no maintenance. DO NOT grease or lubricate any parts of the HWH mechanism.

Any visible mechanism can be kept clean by washing with water. Refer to the vehicle manufacturer for correct maintenance of the room seals.

VISUAL INSPECTION

Periodically inspect the system for oil leaks and damaged or missing parts, such as pivot bolts or springs. Check the hydraulic lines and wiring for damage and wear. Check that the jacks do not interfere with any parts of the vehicle when they are in the "STORE" position.

The system will operate better if kept clean and free from caked on mud or ice.

OPERATIONAL CHECK

Review the OPERATOR MANUAL. Run the system according to the SYSTEM OPERATION Section. Note any abnormal operation.

Review the "JACK RETRACTION" Section. Make sure the jacks will fully retract to the "STORE" position. Jacks should not interfere with any of the coach when in the "STORE" position.

Check that all lights work according to the "INDICATOR LIGHT" Section. Correct function of the red "WARNING" light is important.

MAINTENANCE

NOT IN PARK/BRAKE CHECK

WARNING: WHEN MAKING THIS CHECK, BLOCK THE COACH WHEELS SECURELY SO THE COACH CANNOT ROLL FORWARD OR BACKWARD.

Apply the brake so the coach cannot roll. Turn the ignition to the "ACC" or "ON" position. Release the parking brake. Push the "AUTO LEVEL" button. The "NOT IN PARK/BRAKE" indicator light should come on while the "AUTO LEVEL" button is pushed. Release the "AUTO LEVEL" button and set the park brake. The leveling system should now function.

If any of the above checks or inspections reveal a problem or if there are other problems or questions, consult a qualified RV repair center, your vehicle or coach manufacturer, or HWH CORPORATION for service or repair.

WINTER WEATHER DRIVING

Anti-icing / deicing agents when splashed on your vehicle, continue to absorb moisture from the air even after they have dried. This can facilitate corrosion of metallic components, such as HWH jacks.

To help reduce the corrosion of jacks after exposure to anti-icing / deicing agents, thoroughly wash jacks with warm soapy water.

MAINTENANCE

WINTER WEATHER DRIVING

Due to chemicals used on roads during the winter, it is extremely important the leveling system components are washed with soap and water as soon as possible after driving in winter conditions.

These de-icing chemicals are extremely corrosive and cause severe damage to electrical and hydraulic components.

JACK PRESSURE SWITCH ADJUSTMENT

The jack pressure switches are used to make sure the trailer is properly stabilized after the leveling process is complete.

The switches are adjustable. If set too high, the trailer will be lifted too high. If the switches are set too low the jacks may not come all the way down and lift as necessary.

The jacks should lift the trailer slightly when stabilizing, approximately 1/2".

The trailer should be completely loaded especially at the front when checking the switches.

Before adjusting the switch, unplug the switch so the wire is not twisted. Loosen the locking nut. Turn the threaded adjustment clockwise to increase pressure or counter-clockwise to decrease pressure. Use no more than a half turn before checking the system. Remember to tighten the locking nut when finished.

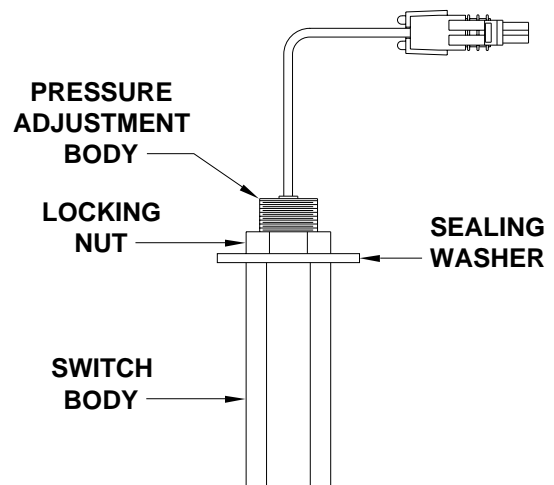

INSTRUCTION SHEET

SENSING UNIT MAINTENANCE/SERVICE

REMOTE MOUNTED "POTTED" ELECTRONIC SENSING UNIT

SENSING UNIT ACCURACY TOLERANCE

The sensing unit has an accuracy tolerance of ± 5.4 inches front to rear and ± 1 inch side to side on a 36 foot vehicle. Typical leveling results will be better.

SENSING UNIT ADJUSTMENT / WITH ADJUSTING ENHANCEMENT

Level the vehicle by placing a bubble level in the center of the freezer floor or upon whichever surface within the vehicle that is to be level. It is best if the level is placed close to the mounting area of the sensing unit. Using the Leveling System and the bubble level, ignoring the yellow LEVEL lights on the Touch Panel, level the vehicle until the bubble is centered.

With the vehicle level according to the bubble level, if there are no yellow lights lit on the Touch Panel, the sensing unit is properly adjusted. If there are yellow LEVEL lights lit on the Touch Panel, manual adjustments to the Sensing Unit are needed.

The ignition (motorized units) or master power switch (towable units) must be on. Remove the "Adjusting Enhancement Cap". **DO NOT LOSE THIS CAP.** There is a small pin beneath the cap. Use a jumper wire with an alligator clip to apply a ground to the pin. This will make the sensing unit very sensitive. The yellow lights may "jump" around while adjusting the sensing unit. Let the lights settle down after each adjustment. Small, gentle turns will work best. Turn mounting screws 1 and 3 to adjust the sensing unit. Turn screws as instructed to turn out all the yellow LEDs. When all the LEDs are out, remove the jumper wire and replace the adjusting enhancement cap. **DO NOT** over tighten.

Move the vehicle to an unlevel position and level the vehicle according to the yellow level sensing lights on the touch panel. Readjust if necessary.

IMPORTANT: THE SENSING UNIT MOUNTING SPRINGS SHOULD BE COMPRESSED ABOUT 1/2 THEIR FREE LENGTH. SCREW NUMBER 2 SHOULD NOT BE TURNED WHILE ADJUSTING THE SENSING UNIT. AFTER ADJUSTING THE SENSING UNIT, BUMP THE SENSING UNIT TO SEE THAT IT IS SETTLED TIGHT AGAINST ALL THREE SCREW HEADS AND STILL INDICATES THAT THE UNIT IS LEVEL.

NOTE: If opposing LED's are lit, there is a problem with the Sensing Unit.

If LED (A) is lit: Tighten adjustment screw number 1 until the LED is off.

If LED (C) is lit: Loosen adjustment screw number 1 until the LED is off.

If LED (B) is lit: Loosen adjustment screw number 3 until the LED is off.

If LED (D) is lit: Tighten adjustment screw number 3 until the LED is off.

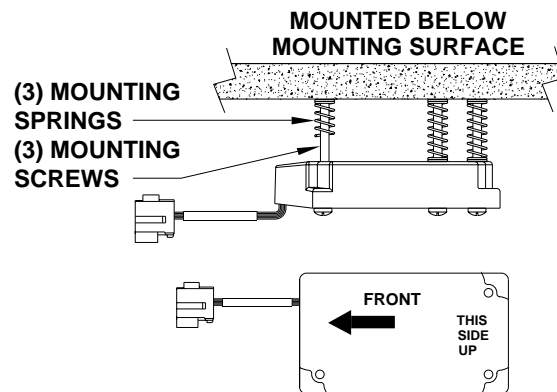
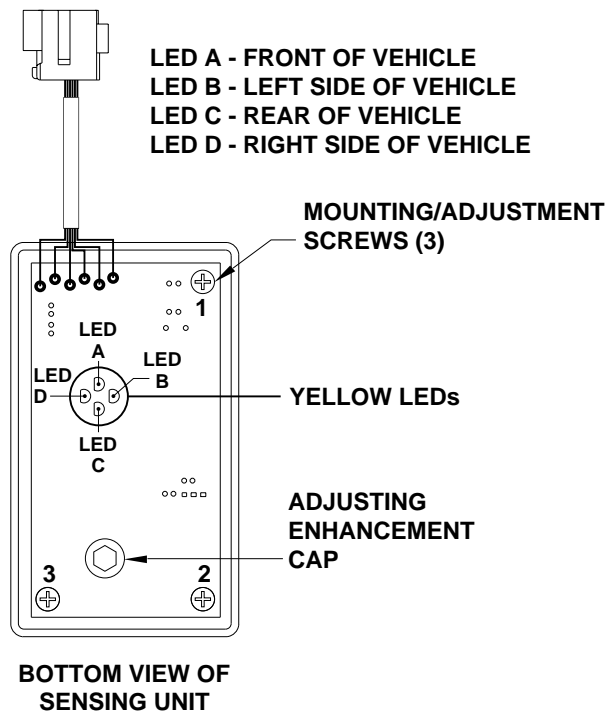

INFORMATION/INSTRUCTION SHEET

HYDRAULIC SOLENOID VALVE

IDENTIFICATION - MANUAL OPERATIONS - REPLACEMENT

REPLACEMENT VALVES WILL HAVE A VALVE RELEASE CAM

BREATHER CAP W/NUT DRIVER

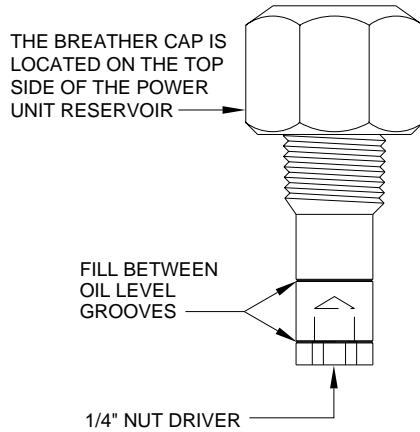

IMPORTANT: PRIOR TO REMOVING THE BREATHER CAP, EITHER TO CHECK THE OIL LEVEL OR TO USE 1/4" NUT DRIVER, CLEAN ANY DEBRIS FROM THE TOP OF THE RESERVOIR. BEFORE RETURNING THE BREATHER CAP TO THE RESERVOIR, REMOVE ANY PAINT CHIPS OR OTHER DEBRIS FROM THE DIPSTICK INCLUDING DEBRIS INSIDE THE 1/4" NUT DRIVER.

SOLENOID VALVES WITH CAM RELEASE

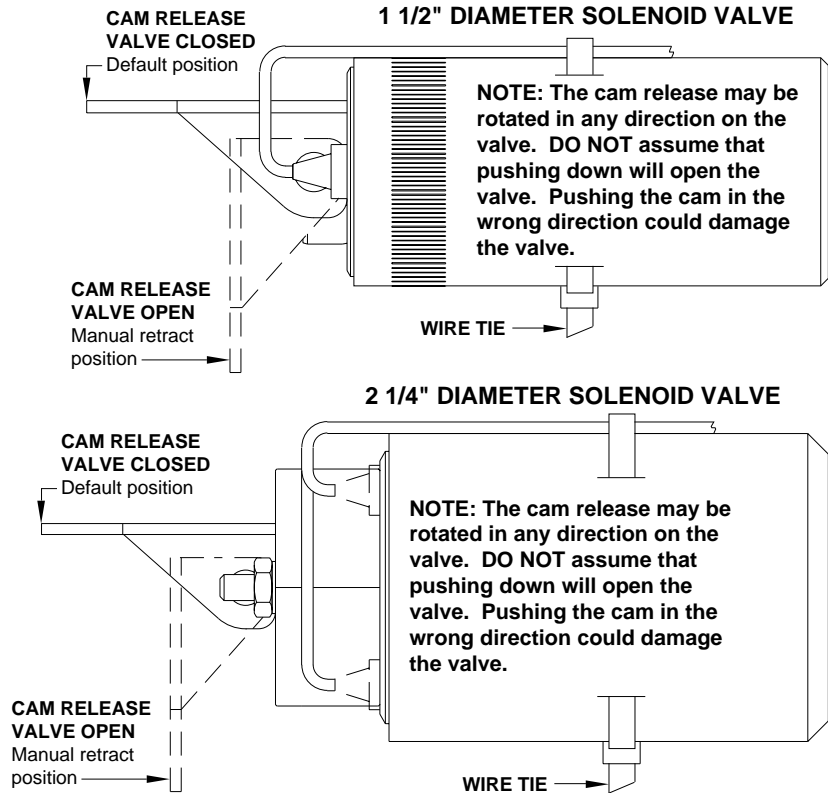

SOLENOID VALVES WITH 1/4" NUT RELEASE

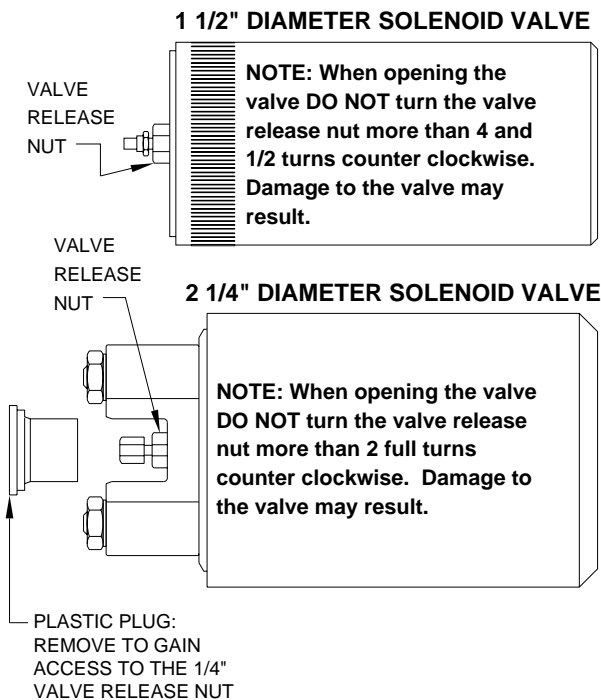

SOLENOID VALVES WITH T-HANDLE RELEASE

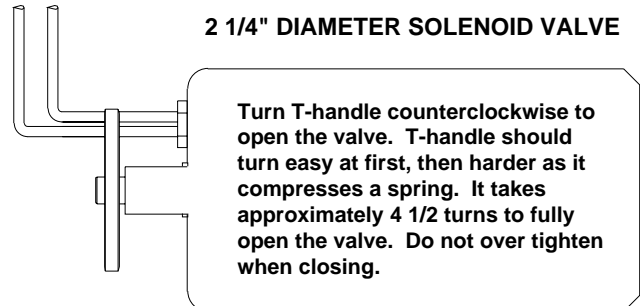

NOTE: OLD STYLE HEX SHAPED SOLENOID VALVES HAVE NO MANUAL VALVE RELEASE.