



# OPERATOR'S MANUAL

## HWH® ACTIVE AIR SUSPENSION HWH® HYDRAULIC LEVELING - ADDENDUM

### **FEATURING:**

*Color LCD Control Module  
BI-AXIS® Hydraulic Leveling  
Straight-Acting Jacks*

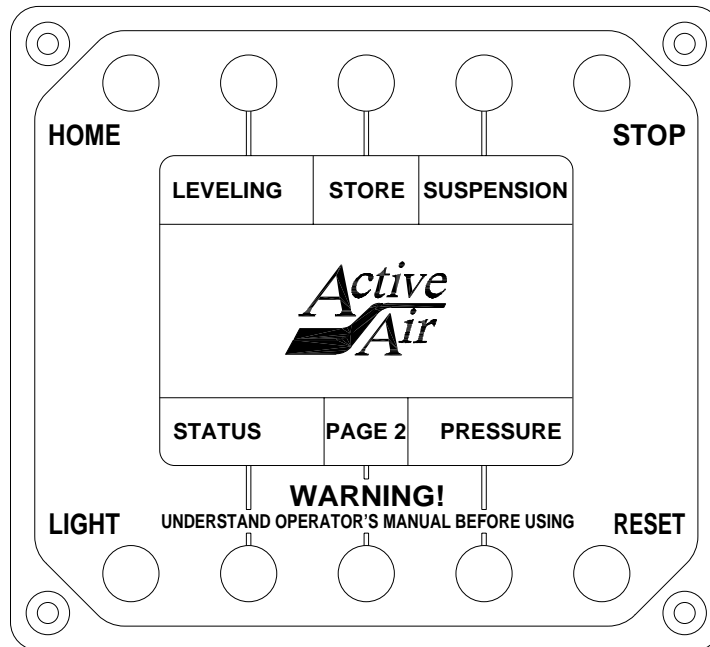

### **HWH CORPORATION**

(On I-80, Exit 267 South)

2096 Moscow Road | Moscow, Iowa 52760

Ph: 800/321-3494 (or) 563/724-3396 | Fax: 563/724-3408

[www.hwh.com](http://www.hwh.com)

---

# OPERATOR'S MANUAL

---

## WARNING !

READ THE ENTIRE OPERATOR MANUAL BEFORE OPERATING.

BLOCK FRAME AND TIRES SECURELY BEFORE CRAWLING UNDER VEHICLE. DO NOT USE LEVELING JACKS OR AIR SUSPENSION TO SUPPORT VEHICLE WHILE UNDER VEHICLE OR CHANGING TIRES. VEHICLE MAY DROP AND/OR MOVE FORWARD OR BACKWARD WITHOUT WARNING CAUSING INJURY OR DEATH.

KEEP ALL PEOPLE CLEAR OF VEHICLE WHILE OPERATING LEVELING SYSTEM OR ROOM EXTENSIONS.

KEEP ALL PEOPLE CLEAR OF VEHICLE WHILE DUMPING AIR FROM THE VEHICLE'S SUSPENSION.

DO NOT MOVE THE VEHICLE IF THE VEHICLE IS NOT AT THE PROPER RIDE HEIGHT. CONTACT MANUFACTURER TECHNICAL SERVICE FOR MOVING THE VEHICLE WHEN NOT AT THE PROPER RIDE HEIGHT.

WEAR SAFETY GLASSES WHEN INSPECTING OR SERVICING THE SYSTEM TO PROTECT EYES FROM DIRT, METAL CHIPS, OIL LEAKS, ETC. FOLLOW ALL OTHER APPLICABLE SHOP SAFETY PRACTICES.

IMPORTANT: IF COACH IS EQUIPPED WITH A ROOM EXTENSION, READ ROOM EXTENSION SECTION BEFORE OPERATING LEVELING SYSTEM.

HWH maintains technical and information services at 800-321-3494 or 563-724-3396. Assistance is available Monday thru Friday from 8:00A.M until 5:00P.M. C.S.T.

Technical and information service is also available on-line at [www.hwh.com](http://www.hwh.com).

# CONTROL IDENTIFICATION

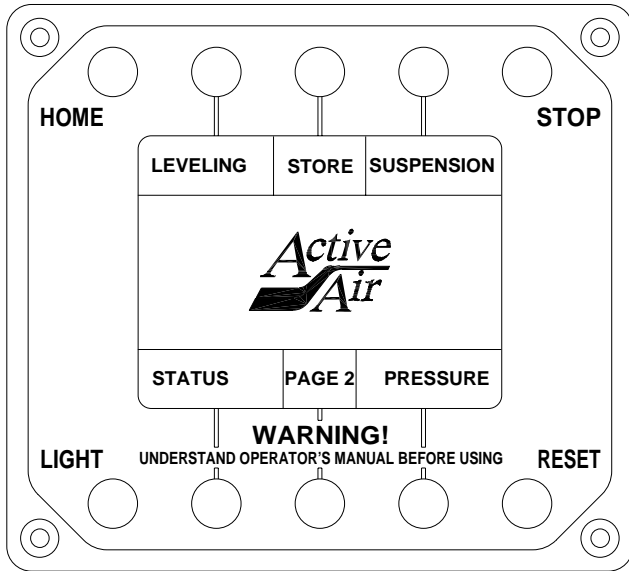

## HOME PAGE

**NOTE:** See individual function pages in the OPERATING PROCEDURES section of this manual for detailed information about specific screen buttons.

## SCREEN BUTTONS AND LIGHTS

**"LEVELING" BUTTON:** This button will bring up options for manual or automatic leveling. If the park brake is not set, this button will not function.

**"STORE" BUTTON:** This button will put the system in the Travel Mode. If Manual or Automatic Hydraulic leveling was used, the first thing that happens is that air is pumped into the suspension air bags for 10 seconds and the word "STORE" will flash continuously until the jacks are fully retracted and the suspension is at ride height. When "RETURNING TO RIDE HEIGHT" is no longer displayed, the suspension is in Travel Mode.

**MASTER "JACKS DOWN" WARNING LIGHT:** This is a light mounted in the dash separate from the touch panel. It will be on when any one or more jacks are extended and the ignition is "ON".

**BUZZER:** This is a jacks down warning. It will sound if the master "JACKS DOWN" warning light is on.

## LEVELING PAGE

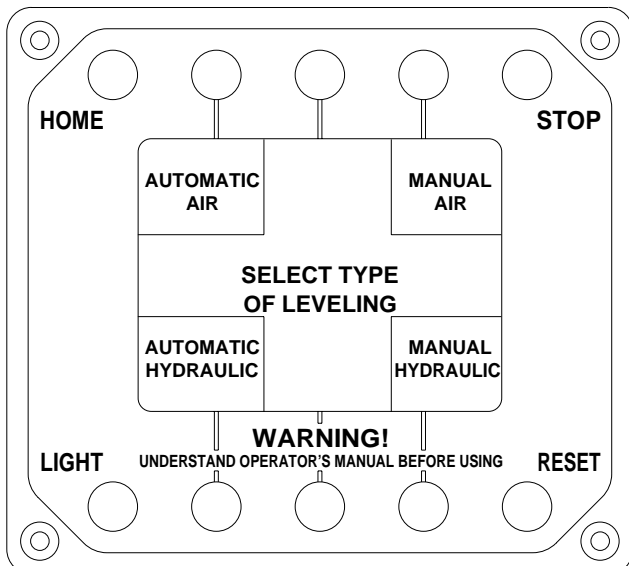

**"AUTOMATIC HYDRAULIC" BUTTON:** This button will put the system in the automatic hydraulic leveling mode and will immediately begin the hydraulic leveling process.

**SEE: MP34.2762**

**WARNING:** PRIOR TO PUSHING THE "AUTO HYDRAULIC" BUTTON THE OPERATOR MUST BE SURE THAT ALL PERSONS AND OBJECTS ARE CLEAR OF THE VEHICLE. AIR WILL BE EXHAUSTED FROM THE VEHICLE SUSPENSION AND THE VEHICLE WILL LOWER IMMEDIATELY AFTER THE "AUTO HYDRAULIC" BUTTON IS PUSHED.

**"MANUAL HYDRAULIC" BUTTON:** This button will bring up the manual hydraulic leveling screen. **SEE: MP34.3338**

# CONTROL IDENTIFICATION

**SCREEN BUTTONS: "PAGE FORWARD / BACK" BUTTONS:** Use these buttons to switch from status screen to status screen.

## STATUS PAGE 4

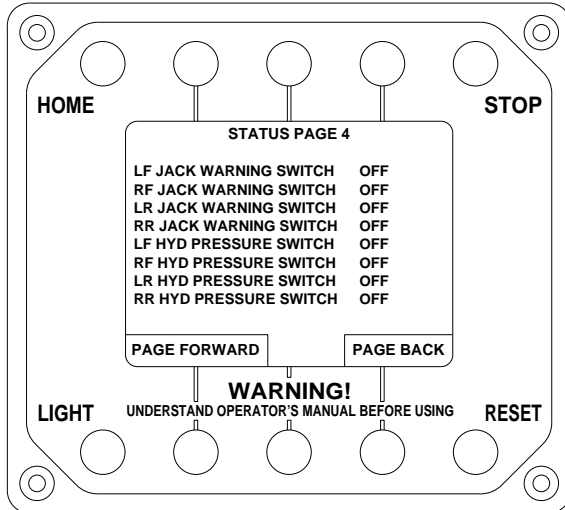

## PAGE 4 STATUS DESIGNATIONS

**NOTE:** This "STATUS PAGE" is specific to HWH hydraulic leveling systems **ONLY**.

"LF JACK WARNING SWITCH"  
"RF JACK WARNING SWITCH"  
"LR JACK WARNING SWITCH"  
"RR JACK WARNING SWITCH"

OFF - Jack is "FULLY" retracted  
ON - Jack is extended

"LF HYD PRESSURE SWITCH"  
"RF HYD PRESSURE SWITCH"  
"LR HYD PRESSURE SWITCH"  
"RR HYD PRESSURE SWITCH"

OFF - Jack has no load on it, It is not supporting weight.  
ON - Jack has load on it, it is supporting weight.

---

# CONTROL IDENTIFICATION

## PUMP RUN TIME

---

### PUMP RUN TIME

Pump motors used with HWH leveling systems and room extension systems come in 3 different diameters; 3", 3.7" and 4.5". Contact the vehicle manufacturer or HWH for help with identifying the motor size. **It is important that any time the pump runs for more than three minutes with a 3" motor; or six minutes with a 3.7" or 4.5" motor that the motor is allowed to cool for thirty minutes before continuing. Continuous operation of the pump motor without allowing the motor to cool can damage the motor.** For cold weather information see "COLD WEATHER OPERATIONS" below.

The HWH systems with a computer processor monitor the pump run time and will turn the pump off if the run time exceeds a specified time. This time can vary with different systems. Due to available electronics or system design, the pump run time programs will also vary. Leveling systems and room extensions that are not controlled by a system processor have no pump run time protection. **DO NOT run the pump more than three or six minutes without allowing the pump motor to cool for thirty minutes.**

#### SYSTEM VARIATIONS FOR PUMP RUN TIME

Some systems with rooms run the rooms separate from the system processor. These systems do not monitor pump run time when operating the rooms. **DO NOT run the pump more than three or six minutes without allowing the pump motor to cool for thirty minutes.**

Some systems can be turned back on immediately after the processor turns the pump off. **DO NOT turn the system back on or run the pump without allowing the pump motor to cool for thirty minutes.**

When operating some leveling systems manually or operating the room extensions, the pump will turn off and back on while pushing the control button when the pump run time has been exceeded. **DO NOT continue without allowing the pump motor to cool for thirty minutes.**

With some systems, when the processor has turned the pump off because the run time has been exceeded, power to the HWH system must be turned off and back on before the system will operate. With motorized vehicles, turn the ignition off and back on. With non-motorized vehicles, turn the master power switch for the HWH system off and back on. **DO NOT continue without allowing the pump motor to cool for thirty minutes.**

Some HWH systems are equipped with a lighted reset switch. If the processor turns the pump off because the run time has been exceeded, the light in the reset switch will turn on. The system will not operate until the reset switch is pushed.

**DO NOT continue without allowing the pump motor to cool for thirty minutes.**

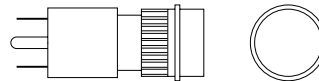

LIGHTED RESET SWITCH

**No matter what HWH system is on the vehicle, the pump should not be ran for more than three minutes (3" motors) or six minutes (3.7" or 4.5" motors) without allowing the pump motor to cool for thirty minutes. Continuous operation of the pump motor without allowing the motor to cool can damage the pump motor.**

Contact HWH corporation to get specific information about the system in this vehicle.

## COLD WEATHER OPERATIONS

HWH leveling and room extension systems are designed to function in cold weather down to 0 degrees Fahrenheit. Below freezing (32 degrees Fahrenheit) the jacks or rooms will operate slower than usual.

For operation in temperatures dropping below -20 degrees Fahrenheit, it is necessary that the system is equipped with oil designed for extreme cold weather application such as a synthetic oil. (Contact HWH for recommendations.)

**DO NOT run the pump motor continuously. It is important that any time the pump runs for more than three minutes with a 3" motor; or six minutes with a 3.7" or 4.5" motor that the motor is allowed to cool for thirty minutes before continuing. Continuous operation of the pump motor without allowing the motor to cool can damage the motor.** Continuous operation of the pump with slow moving jacks or rooms in cold weather, without allowing the pump motor to cool will cause the pump motor to burn up and damage the pump assembly.

# OPERATING PROCEDURES

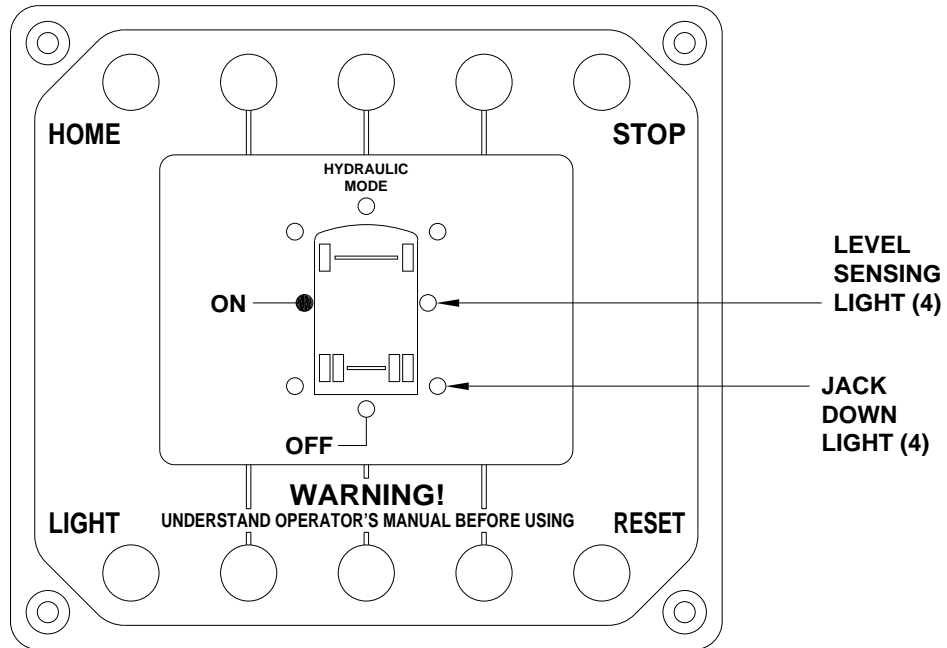

## AUTOMATIC HYDRAULIC LEVELING

1. Place transmission in the recommended position for parking the vehicle and set parking brake. Turn the coach engine off. Turn the ignition key to the "ACCESSORY" position.

2. At this time, the operator may want to check the jacks and place a pad under each jack if the ground will not support the vehicle.

**WARNING:** PRIOR TO PUSHING THE "AUTOMATIC HYDRAULIC" BUTTON THE OPERATOR MUST BE SURE THAT ALL PERSONS AND OBJECTS ARE CLEAR OF THE VEHICLE. AIR WILL BE EXHAUSTED FROM THE VEHICLE SUSPENSION AND THE VEHICLE WILL LOWER IMMEDIATELY AFTER THE "AUTOMATIC HYDRAULIC" BUTTON IS PUSHED.

**NOTE:** Automatic leveling and automatic store can only be started when the "HOME" page is being displayed.

3. Press the "AUTOMATIC HYDRAULIC" button on the LEVELING page. If the park brake is not set, a message will appear on the screen. Push the "HOME" button and correct the problem before pushing the "AUTOMATIC HYDRAULIC" button again.

4. After pressing the "AUTOMATIC HYDRAULIC" button, the HYDRAULIC MODE page will appear. The system will begin to dump air from the vehicle suspension. After approximately 25 seconds, the leveling process will begin.

**IMPORTANT:** During the Automatic Leveling process, pushing the "HOME", "STOP" or the "CANCEL" button on the HWH LCD panel will stop the automatic leveling function.

When a jack extends approximately 1 inch, its individual red jack down light on the LCD panel will come on. If the ignition is in the ON position, the warning buzzer will sound.

**AUTO LEVEL SEQUENCE:** During the automatic leveling sequence, after the system has extended the appropriate jacks to level the vehicle and has turned the yellow level indicator lights off, the system will then stabilize the vehicle.

**STABILIZE SEQUENCE:** The stabilize sequence begins when the Auto Level sequence is complete. Each jack has a pressure switch. The switch will turn on when the jack extends to the ground and lifts the vehicle slightly. Jacks that have lifted the vehicle for leveling should have pressure switches that are on. If the switch is on, the jack is already stabilized. If the switch is not on, the computer turns the pump and valve on for that jack until the pressure switch turns on. Any jack used to stabilize the vehicle will lift the vehicle slightly. When the stabilize procedure is complete, the LCD will display "AUTOMATIC LEVELING SEQUENCE WAS SUCCESSFUL. PRESS HOME TO RETURN TO HOME PAGE." Pressing HOME will return to the HOME page, or the LCD panel will automatically return to the HOME page after approximately 15 seconds.

**EXCESS SLOPE SITUATION:** In the event the jacks are unable to level the coach, the LCD will display "EXCESS SLOPE! AUTOMATIC LEVELING SEQUENCE WAS UNSUCCESSFUL. PRESS HOME TO EXIT." The LCD panel will not return to the HOME page, unless the HOME button is pressed. Excess slope is when one or two jacks extend fully without turning the yellow level light out. The system will not stabilize the vehicle if the "EXCESS SLOPE" message is displayed. One or more jacks may not be extended. Retract the jacks and move the vehicle to a more level position or level the vehicle as close as possible according to the MANUAL HYDRAULIC OPERATION section.

5. Turn the ignition switch to the "OFF" position. The LCD panel will power down in 5 minutes.

---

# OPERATING PROCEDURES

## ACTIVE AIR WITH HYDRAULIC LEVELING SYSTEM

---

### JACK RETRACTION (HWH LCD PANEL)

**WARNING:** THE OPERATOR MUST BE SURE THAT THERE ARE NO OBJECTS UNDER THE VEHICLE AND THAT ALL PEOPLE ARE CLEAR OF THE VEHICLE.

**NOTE:** When the jacks are stored with the ignition in the ON position, the warning buzzer will sound until the jacks have retracted to the STORE position. If desired, the jacks can be stored with the ignition key in the accessory position. This will eliminate the warning buzzer while the jacks are retracting.

It is recommended to retract any room extensions before retracting the jacks.

1. It is recommended to start the engine before storing the jacks. This will allow air pressure to build. If starting the engine before storing the jacks, the HWH "STORE" button should be pushed immediately after starting the engine.

2. Start the engine and press the "STORE" button. The LCD panel will flash the word "STORE". The vehicle should start to return to proper ride height. The front jacks will retract for 5 seconds before the rear jacks will begin to retract. The system will automatically shut down 1 minute after the jacks have retracted. If any one jack has not been fully retracted, the system will continue to store for fifty minutes, then shut down regardless of the jacks down condition.

**NOTE:** When traveling thermal expansion may cause a jack to extend slightly. When the "STORE" button has been used to retract the jacks, the system will automatically retract any jack that extends due to thermal expansion.

**IMPORTANT:** If power to the system is interrupted after starting a store procedure, the store procedure should be reinitiated and the jacks should be completely retracted with all four jacks out prior to traveling.

**IMPORTANT:** During the Automatic Store procedures, pushing the "STOP" or the "RESET" button on the HWH LCD panel will stop the automatic store function.

**WARNING:** DO NOT MOVE THE VEHICLE WHILE THE LEVELING JACKS ARE STILL IN CONTACT WITH THE GROUND OR IN THE EXTEND POSITION. THIS VEHICLE IS EQUIPPED WITH STRAIGHT-ACTING JACKS. MOVING THE VEHICLE WITH THE LEVELING JACKS EXTENDED CAN CAUSE SEVERE DAMAGE TO THE JACKS AND OR THE VEHICLE AND CREATE A DRIVING HAZARD. DO NOT RELY SOLELY UPON WARNING LIGHTS. IT IS THE OPERATOR'S RESPONSIBILITY TO CHECK THAT ALL JACKS ARE FULLY RETRACTED INTO THE STORE POSITION AND THE VEHICLE IS AT THE PROPER RIDE HEIGHT.

3. The vehicle can be moved as soon as the word "STORE" stops flashing, the jacks are in the STORE position and the warning light and buzzer turn off, if the vehicle is at the proper ride height for traveling.

**IMPORTANT:** If the red warning light and buzzer come on while traveling, the jacks and ride height should be checked as soon as a safe parking location is found.

4. If jacks cannot be retracted by the above procedure see MANUAL JACK RETRACTION Section below.

### MANUAL JACK RETRACTION

The solenoid valves on the power unit valve assembly are equipped with a manual valve release. Use the manual valve release for retracting only if the "STORE" button on the LCD panel will not retract the jacks for travel.

**NOTE:** Assemblies can have different combinations of large and / or small valves.

**NOTE:** If the Active Air system has been installed on a coach with an existing HWH hydraulic leveling system, the valves may not have release cams as shown. See MP84.9999 for valve release information.

**WARNING:** KEEP AWAY FROM THE WHEELS, DO NOT CRAWL UNDER THE VEHICLE, KEEP A SAFE DISTANCE IN FRONT AND REAR OF THE VEHICLE. THE VEHICLE MAY DROP AND/OR MOVE FORWARD OR BACKWARD WITHOUT WARNING AS THE VALVE RELEASE IS OPERATED.

1. Locate the manual valve release on each solenoid valve. The solenoid valves are located on the power unit/valve assembly.

2. Allow clearance for the vehicle to lower.

**Large and small valves will be equipped with a valve release cam. The cam might be rotated in any direction on the valve. Pushing the release cam in the wrong direction may damage the valve.**

3. Retract the front jacks by slowly opening the two center valves.

4. Repeat the process for the rear jacks by opening the two outer valves.

5. Check that all four jacks are now retracted.

6. Close the valves by moving the valve release cam to the closed position.

7. The system should now be repaired before using again.

#### VALVE RELEASE CAM OPERATION

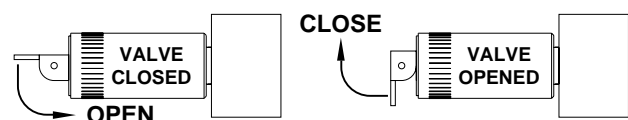

MP34.3064A  
27JUL15

# OPERATING PROCEDURES

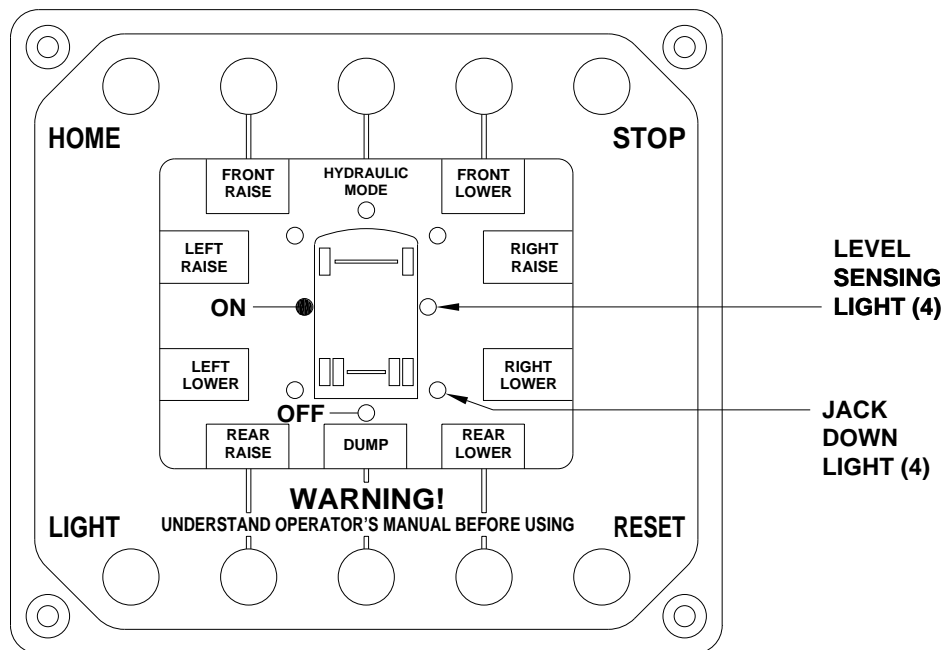

## MANUAL HYDRAULIC LEVELING

### **WARNING: KEEP PEOPLE AND OBJECTS CLEAR OF THE VEHICLE WHILE OPERATING THE HYDRAULIC LEVELING SYSTEM.**

1. Place transmission in the recommended position for parking the vehicle, and set the parking brake. Turn the ignition to the "ACCESSORY" position.
2. Place pads under the jack feet if the ground will not support the vehicle on the jacks.
3. Press the "MANUAL HYDRAULIC" button on the LEVELING page. If the park brake is removed, the system will return to the "HOME" page.
4. After pressing the "MANUAL HYDRAULIC" button, the MANUAL HYDRAULIC MODE page will appear.
5. Push the "DUMP" button. Wait until all air is exhausted from the vehicle suspension.
6. The vehicle may be leveled by pressing and holding the manual RAISE or LOWER buttons to operate the corresponding jacks. If a yellow LEVEL SENSING LIGHT is on, that side, end or corner of the vehicle is low. It is best to level the vehicle side to side first, if needed, before front to rear. Press and hold the RAISE button on the low side / end until the yellow light turns off.

When a jack extends approximately 1 inch, its individual red jack down light on the LCD panel will come on. If the ignition is in the ON position, the warning buzzer will sound.

Jacks will extend (or retract) in pairs to raise (or lower) a side or end of the vehicle.

Any jack not used for leveling can be extended to the ground. This provides additional stability against wind and activity in the vehicle. Jacks used to stabilize the vehicle after leveling is complete should lift the vehicle slightly after touching the ground.

**IMPORTANT: Do not continue to push an EXTEND button for more than ten (10) seconds after that pair of jacks are fully extended.**

7. When leveling is completed, turn the ignition switch to the "OFF" position. The LCD panel will power down in five minutes.



---

# MAINTENANCE

---

## OIL LEVEL

All maintenance should be done as part of the normal servicing of the coach.

The oil level should be checked when the vehicle is first purchased and then once every two years. More often if there is an oil leak in the system.

Any HWH hydraulic equipment, including jacks, slide-outs and steps should be fully retracted before checking fluid level. The oil reservoir is part of the pump / manifold assembly. The oil level is checked and filled through the breather cap. Clear any dirt away from the breather / filler cap before removing.

The oil level should be within one inch of the top of the reservoir. Most breather caps have a dipstick. Fluid level should be between the bottom of the dipstick and the center mark.

**NOTE: Overfilling the tank can cause leakage of oil through the breather cap.**

**FLUID:** HWH Specialty Hydraulic Oil is recommended. In an emergency Dexron automatic transmission fluid can be used. **NOTE:** Dexron automatic transmission fluid contains red dye and can cause staining should a leak occur. **DO NOT USE** brake fluid or hydraulic jack fluid. Use of these can damage seals.

## ELECTRICAL SYSTEM

The batteries should be in good condition and fully charged. Weak batteries can cause erratic operation. Battery cable terminals and battery posts and connections should be kept clean.

All electrical connections, especially ground connections, should be clean, tight, free from corrosion and protected from weathering.

## JACKS

There are very few user serviceable parts on the jacks. The jacks require very little maintenance. If the jacks are extremely dirty with caked on mud they should be washed.

If extremely dirty, the jack rods should NOT be wiped. The jack rods do not need to be oiled or sprayed with anything. See ML47149 for proper maintenance of all jacks.

## ROOM EXTENSIONS

The HWH room mechanisms need no maintenance. DO NOT grease or lubricate any parts of the HWH mechanism.

Any visible mechanism can be kept clean by washing with water. Refer to the vehicle manufacturer for correct maintenance of the room seals.

## VISUAL INSPECTION

Periodically inspect the system for oil leaks and damaged or missing parts, such as pivot bolts or springs. Check the hydraulic lines and wiring for damage and wear. Check that the jacks do not interfere with any parts of the vehicle when they are in the "STORE" position.

The system will operate better if kept clean and free from caked on mud or ice.

## OPERATIONAL CHECK

Review the OPERATOR MANUAL. Run the system according to the SYSTEM OPERATION Section. Note any abnormal operation.

Review the "JACK RETRACTION" Section. Make sure the jacks will fully retract to the "STORE" position. Jacks should not interfere with any of the coach when in the "STORE" position.

Check that all lights work according to the "INDICATOR LIGHT" Section. Correct function of the red "WARNING" light is important.

---

## MAINTENANCE

---

### NOT IN PARK/BRAKE CHECK

**WARNING: WHEN MAKING THIS CHECK, BLOCK THE COACH WHEELS SECURELY SO THE COACH CANNOT ROLL FORWARD OR BACKWARD.**

Apply the brake so the coach cannot roll. Turn the ignition to the "ACC" or "ON" position. Release the parking brake. Push the "AUTO LEVEL" button. The "NOT IN PARK/BRAKE" indicator light should come on while the "AUTO LEVEL" button is pushed. Release the "AUTO LEVEL" button and set the park brake. The leveling system should now function.

If any of the above checks or inspections reveal a problem or if there are other problems or questions, consult a qualified RV repair center, your vehicle or coach manufacturer, or HWH CORPORATION for service or repair.

### WINTER WEATHER DRIVING

Anti-icing / deicing agents when splashed on your vehicle, continue to absorb moisture from the air even after they have dried. This can facilitate corrosion of metallic components, such as HWH jacks.

To help reduce the corrosion of jacks after exposure to anti-icing / deicing agents, thoroughly wash jacks with warm soapy water.

---

## MAINTENANCE

---

### NOT IN PARK/BRAKE CHECK

**WARNING: WHEN MAKING THIS CHECK, BLOCK THE COACH WHEELS SECURELY SO THE COACH CANNOT ROLL FORWARD OR BACKWARD.**

Apply the brake so the coach cannot roll. Turn the ignition key to the "ACC" or "ON" position. Release the parking brake. Push the "AUTO HYD" button on the HOME page. The LCD panel should display the message "YOU ARE ATTEMPTING TO OPERATE A FUNCTION THAT REQUIRES THE PARK BRAKE TO BE SET. PRESS HOME TO EXIT." Press the home button, set the park brake, and then press the "AUTO HYD" button. The leveling system should now function.

If any of the above checks or inspections reveal a problem or if there are other problems or questions, consult a qualified RV repair center, your vehicle or coach manufacturer, or HWH CORPORATION for service or repair.

# HYDRAULIC LINE CONNECTION DIAGRAM

## ACTIVE AIR SUSPENSION WITH HYDRAULIC LEVELING SYSTEM (WITH 4 STRAIGHT-ACTING JACKS)

MANIFOLDS MAY HAVE FOUR (4) LARGE VALVES OR FOUR (4) SMALL VALVES

**NOTE:** BEFORE OPERATING MANUAL VALVE RELEASE, READ AND UNDERSTAND PROCEDURE FOR MANUAL JACK RETRACTION IN OPERATOR'S INSTRUCTIONS. VALVES MAY BE EQUIPPED WITH VALVE RELEASE NUTS OR RELEASE CAMS.

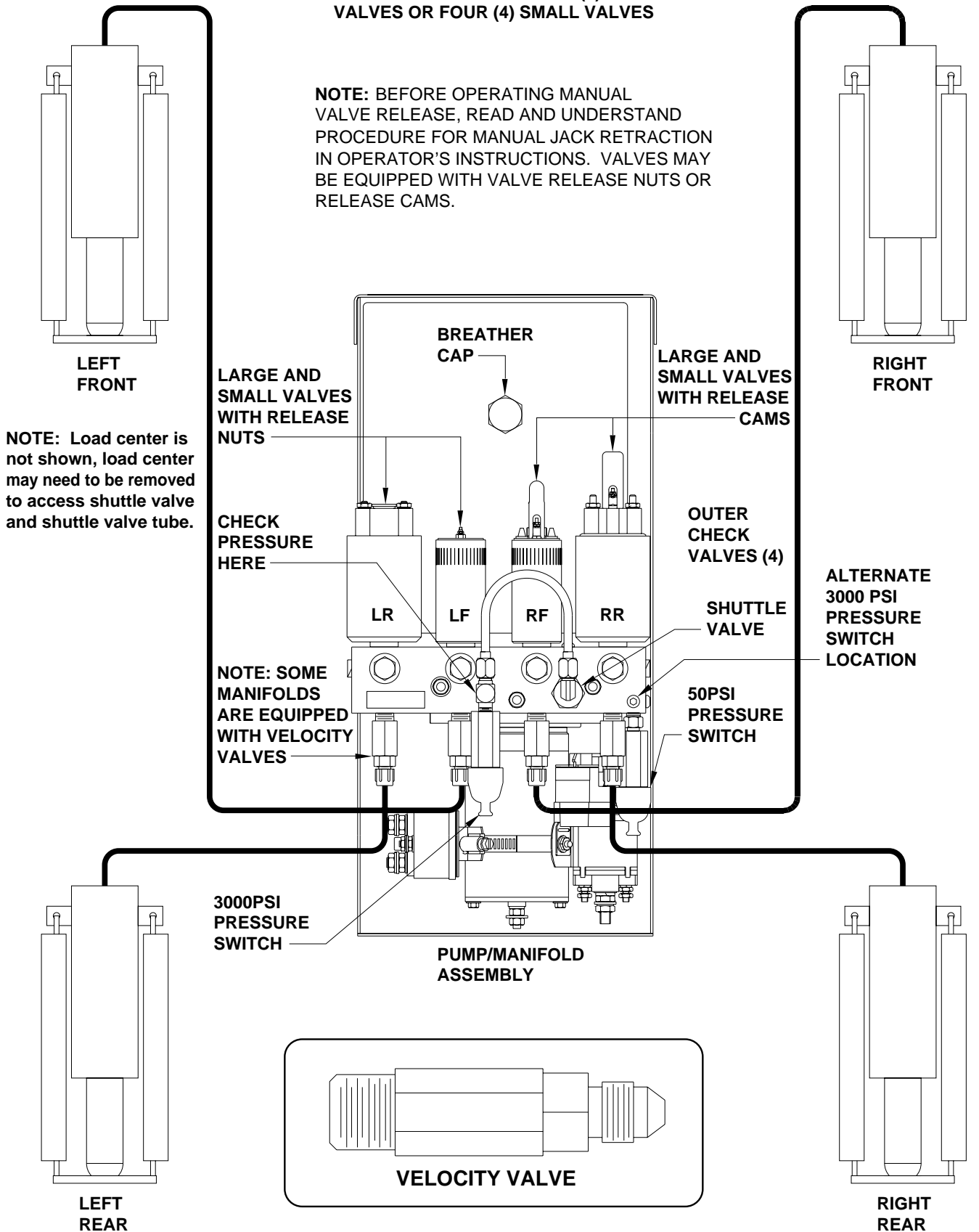

ALTERNATE  
3000 PSI  
PRESSURE  
SWITCH  
LOCATION

# HYDRAULIC SCHEMATIC DIAGRAM

## BI-AXIS LEVELING WITH STRAIGHT-ACTING JACKS

### ACTIVE AIR SUSPENSION WITH HYDRAULIC LEVELING SYSTEM

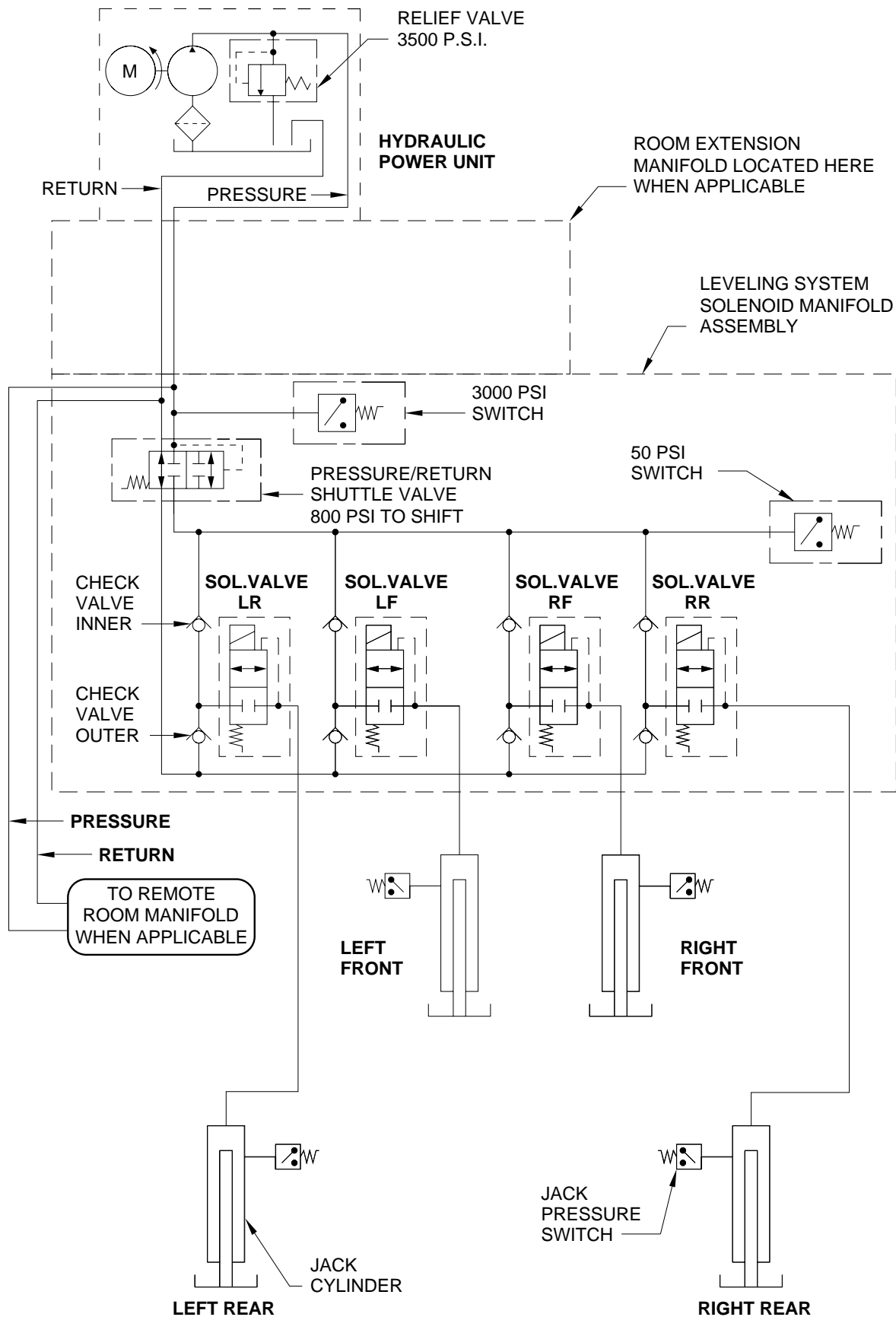

# INFORMATION/INSTRUCTION SHEET

## HYDRAULIC SOLENOID VALVE

### IDENTIFICATION - MANUAL OPERATIONS - REPLACEMENT

**REPLACEMENT VALVES WILL HAVE A VALVE RELEASE CAM**

#### BREATHER CAP W/NUT DRIVER

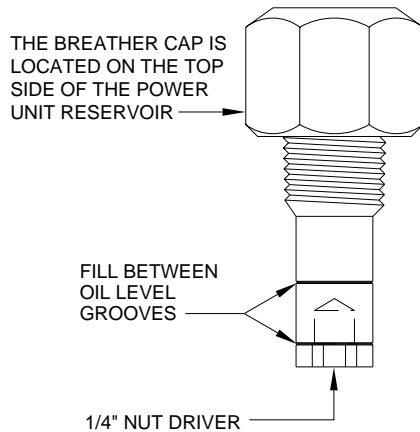

**IMPORTANT: PRIOR TO REMOVING THE BREATHER CAP, EITHER TO CHECK THE OIL LEVEL OR TO USE 1/4" NUT DRIVER, CLEAN ANY DEBRIS FROM THE TOP OF THE RESERVOIR. BEFORE RETURNING THE BREATHER CAP TO THE RESERVOIR, REMOVE ANY PAINT CHIPS OR OTHER DEBRIS FROM THE DIPSTICK INCLUDING DEBRIS INSIDE THE 1/4" NUT DRIVER.**

#### SOLENOID VALVES WITH CAM RELEASE

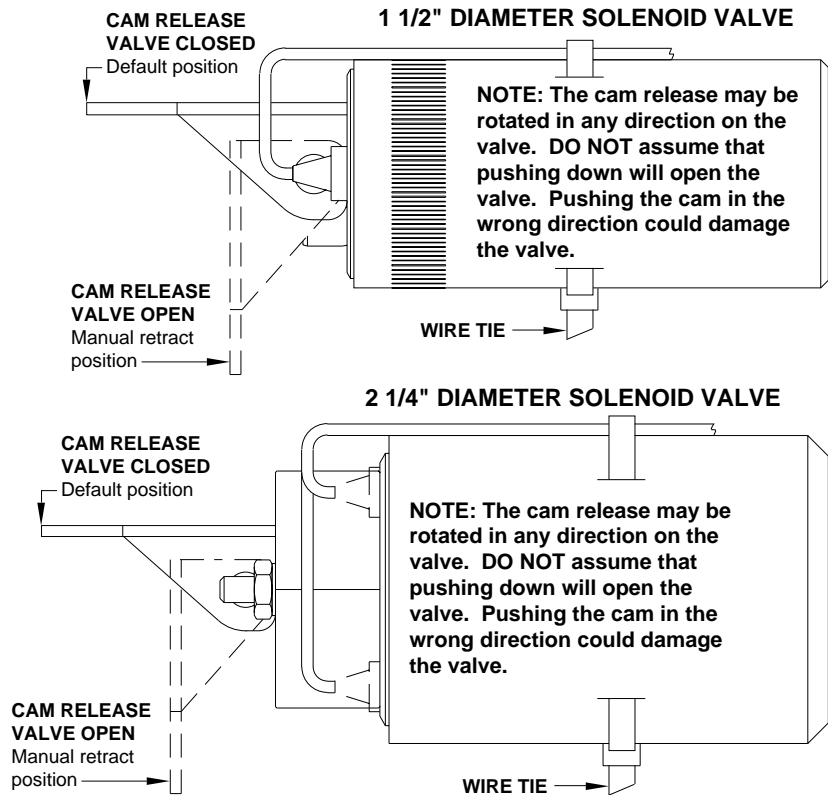

#### SOLENOID VALVES WITH 1/4" NUT RELEASE

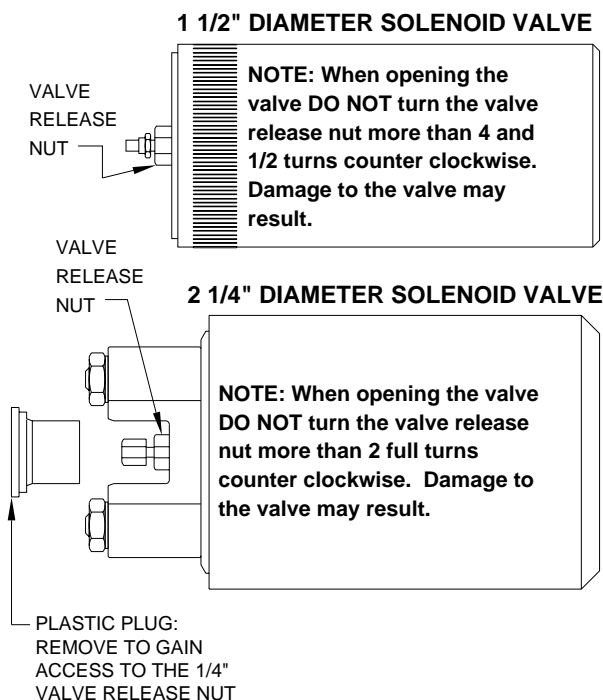

#### SOLENOID VALVES WITH T-HANDLE RELEASE

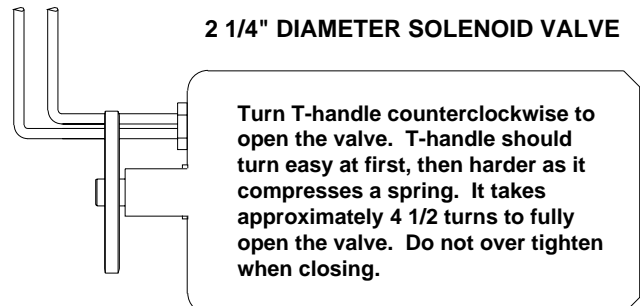

**NOTE: OLD STYLE HEX SHAPED SOLENOID VALVES HAVE NO MANUAL VALVE RELEASE.**