

- Ⓐ AP4310 HOSE ASSY 04 x 204' PRESSURE
- Ⓑ .375" OD NYLON TUBING RETURN
- Ⓒ AP53067 HOSE ASSY 03 x 276' RDD END - ALWAYS PRESSURIZED HOSES MUST BE HIGH PRESSURE AND OF EQUAL LENGTH AND DIAMETER
- Ⓓ AP5965 HOSE ASSY 04 x 180' CAP END - HOSES MUST MAINTAIN EQUAL LENGTH AND DIAMETER
- Ⓙ AP2445 HOSE ASSY 04 x 90' CAP END (LIFT)
- Ⓚ AP50766 HOSE ASSY 03 x 96' CAP END (ROOM)
- Ⓛ AP51480 HOSE ASSY 03 x 66' CAP END (ROOM)
- Ⓜ AP50908 HOSE ASSY 03 x 54' RDD END (LIFT) ALWAYS PRESSURIZED
- Ⓝ AP50908 HOSE ASSY 03 x 54' CAP END (LIFT)
- Ⓞ AP53964 HOSE ASSY 04 x 114' RDD END (LIFT) ALWAYS PRESSURIZED
- Ⓟ AP50779 HOSE ASSY 03 x 144' RDD END (LIFT) ALWAYS PRESSURIZED
- Ⓠ AP50779 HOSE ASSY 03 x 144' CAP END (LIFT)
- Ⓡ AP50908 HOSE ASSY 03 x 54' RDD END (LIFT) ALWAYS PRESSURIZED
- Ⓢ AP50908 HOSE ASSY 03 x 54' CAP END (LIFT)
- Ⓣ AP50779 HOSE ASSY 03 x 144' RDD END (LIFT) ALWAYS PRESSURIZED
- Ⓤ AP50779 HOSE ASSY 03 x 144' CAP END (LIFT)

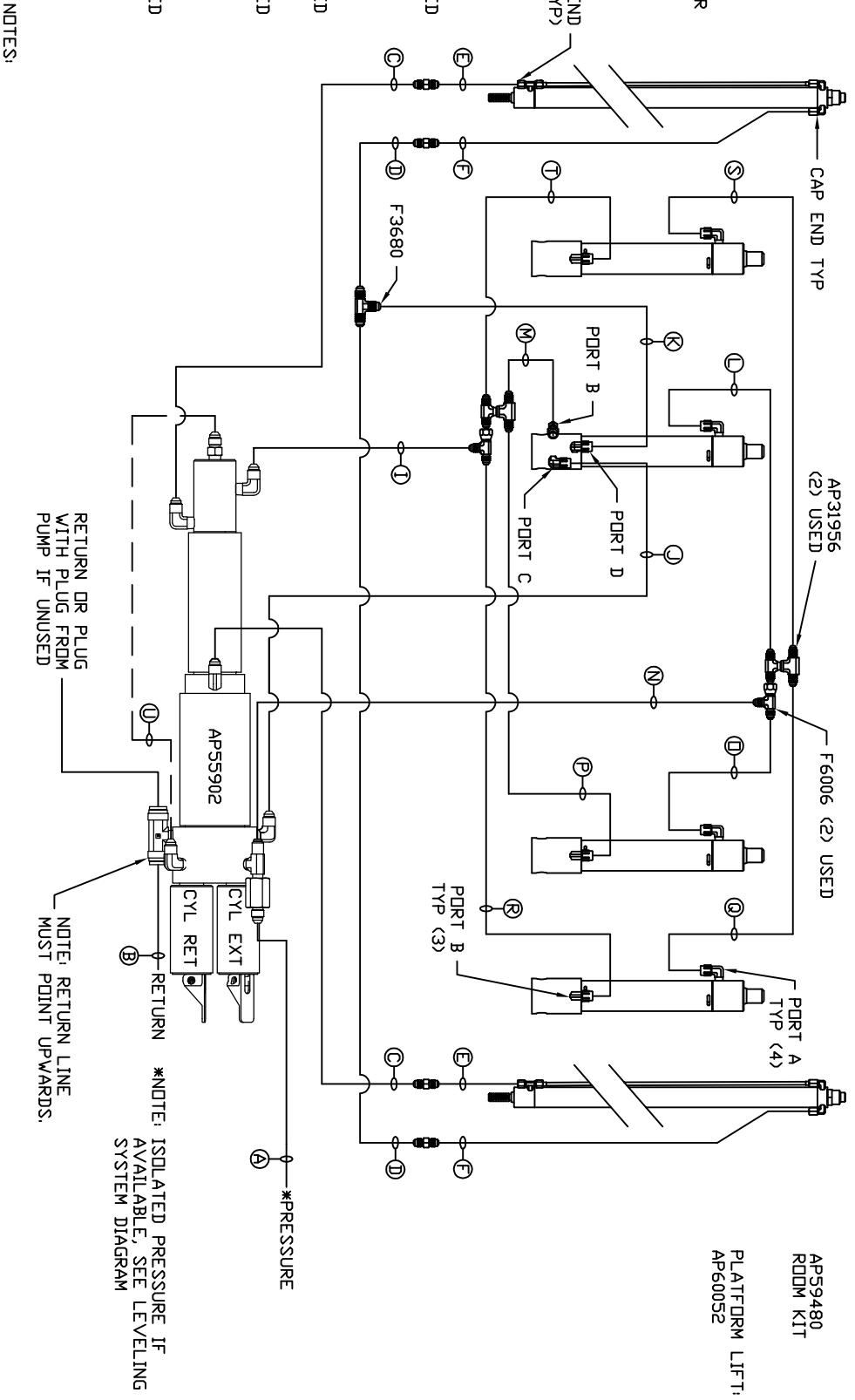

NOTES:

FOR CONNECTION CLARITY ONLY THE CYLINDERS ARE SHOWN.
 HOSE Ⓣ IS INCLUDED WITH THE SYNC. CYLINDER.
 LIFT CYLINDERS VIEWED FROM THE INSIDE
 LOOKING OUTWARD

NOTE: INSTALLATION MUST CONFORM TO GOOD SHOP PRACTICES, SAE STANDARDS, RYVIA STANDARDS, AND OTHER APPLICABLE STANDARDS.

HWH		1-80 EXIT 267 SOUTH	
RT 1 MOSCOW, IOWA 52760		DRAWN BY	
SCALE 1:6	DATE 14NOV19	REV GROUP	
HYD CONN DIAGRAM		DRAWING NUMBER	
NO.	DATE	REVISION	MP71241

THE INFORMATION DISCLOSED ON THIS DRAWING IS CONFIDENTIAL AND MUST NOT BE DISCLOSED OR USED IN ANY MANNER WHICH WILL BE DETRIMENTAL TO THE HWH CORPORATION