

AP24299
FRONT AIR MODULE

* DESIGNATES PIN 1 OF CONNECTORS

AP22521 CN1 (BROWN)

- PIN
- 1 N/C
 - 2 BLK (W1500) LEFT FRONT RAISE
 - 3 BLK (W1600) LEFT FRONT LOWER
 - 4 BLK (W2500) RIGHT FRONT RAISE
 - 5 BLK (W2600) RIGHT FRONT LOWER
 - 6 BLK (W9700) COMPRESSOR
 - 7 N/C
 - 8 BLK (W1700) TRAVEL
 - 9 N/C
 - 10 N/C
 - 11 WHT (W6254) GROUND
 - 12 N/C

CN98 (GRAY)

- PIN
- 1 RED (W6800) SW BATT
 - 2 RED (W6800) SW BATT
 - 3 GRN (W6230) GND
 - 4 GRN (W6230) GND

AP24300 CN1 (BLACK)

- PIN
- 1 N/C
 - 2 N/C
 - 3 RED(W6800) SW BATTERY
 - 4 GRN(W6230) GROUND
 - 5 CAN SHIELD
 - 6 N/C
 - 7 GRN CAN LOW
 - 8 YEL CAN HI

AP22698 CN9 (BLACK)

- PIN
- 1 WHT(W7696) SYSTEM WAKE UP
 - 2 N/C
 - 3 RED(W6800) SW BATTERY
 - 4 GRN(W6230) GROUND
 - 5 CAN SHIELD
 - 6 RED(W6110) IGNITION
 - 7 GRN CAN LOW
 - 8 YEL CAN HI

AP22698 CN10 (GRAY)

- PIN
- 1 N/C
 - 2 N/C
 - 3 N/C
 - 4 N/C
 - 5 N/C
 - 6 N/C

AP22698 CN12 (GRAY)

- PIN
- 1 N/C
 - 2 N/C
 - 3 N/C
 - 4 N/C
 - 5 N/C
 - 6 WHT(W6236) GROUND
 - 7 N/C
 - 8 N/C
 - 9 N/C
 - 10 BLK(W2210) RIGHT FRONT PSW
 - 11 N/C
 - 12 N/C

AP22698 CN11 (GREEN)

- PIN
- 1 N/C
 - 2 N/C
 - 3 N/C
 - 4 N/C
 - 5 N/C
 - 6 WHT(W6235) GROUND
 - 7 N/C
 - 8 N/C
 - 9 N/C
 - 10 BLK(W1210) LEFT FRONT PSW
 - 11 N/C
 - 12 N/C

		HWH I-80 EXIT 267 SOUTH RT 1 MOSCOW, IOWA 52760	
		SCALE 1:3	DATE 03MAR05
		DRAWN BY .	
▲	01DEC06	REM'D RM 2 LOCK SH B,G,N	
NO.	DATE	REVISION	
		SYSTEM SCHEMATIC ELEC	
THE INFORMATION DISCLOSED ON THIS DRAWING IS CONFIDENTIAL AND MUST NOT BE DISCLOSED OR USED IN ANY MANNER WHICH WILL BE DETRIMENTAL TO THE HWH CORPORATION			DRAWING NUMBER MP88692 A/Q

AP24062
CENTRAL CONTROL/ROOM 1 MODULE

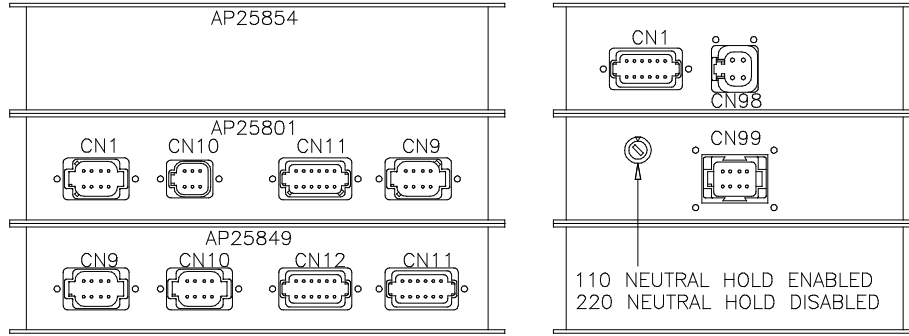

AP24065 CN1 (BROWN)

PIN	Color	Description
1	BLK(W5050)	CYLINDER EXTEND1
2	BLK(W5150)	CYLINDER RETRACT1
3	BLK(W5200)	LOCK ROOM 1
4	BLK(W5300)	UNLOCK ROOM 1
5	BLK(W5051)	CYLINDER EXTEND2
6	BLK(W5151)	CYLINDER RETRACT2
7	BLK(W5600)	AIR SEAL
8	BLK(W5650)	VACUUM
9	N/C	
10	N/C	
11	N/C	
12	N/C	

⚠️

CN98 (GRAY)

PIN	Color	Description
1	RED (W6801)	SW BATT
2	RED (W6801)	SW BATT
3	GRN (W6230)	GND
4	GRN (W6230)	GND

AP22882 CN1 (BLACK)

PIN	Color	Description
1	WHT(W7696)	SYSTEM WAKE UP
2	N/C	
3	RED(W6800)	SW BATT
4	GRN(W6230)	GND
5	CAN SHIELD	
6	RED(W6110)	IGNITION
7	GRN CAN LOW	
8	YEL CAN HI	

AP22882 CN10 (GRAY)

PIN	Color	Description
1	WHT (W7599)	RST LGT CNTRL
2	WHT (W6100)	RST LGT SUPPLY
3	WHT (W7550)	RST BUTTON CNTRL
4	WHT (W6121)	WARN LIGHT SUPPLY
5	WHT (W6230)	RESET BUTTON GND
6	WHT (W7699)	WARN LIGHT CNTRL

AP22882 CN11 (GRAY)

PIN	Color	Description
1	RED (W6110)	IGNITION
2	N/C	
3	N/C	
4	N/C	
5	RED (W6120)	ACCESSORY
6	RED (W6100)	HOUSE BATTERY
7	GRN (W6230)	GROUND
8	WHT (W9961)	NEUTAL HOLD
9	WHT (W9955)	NEUTRAL HOLD
10	N/C	
11	WHT (W9000)	PARK BRAKE SWITCH
12	RED (W6101)	ENGINE BATTERY

AP22882 CN9 (GREEN)

PIN	Color	Description
1	BLK (W8500)	MASTER RELAY CNTRL
2	BLK (W8100)	SYSTEM PSW.
3	N/C	
4	BLK (W8600)	PMP RELAY CNTRL
5	BLK (W9900)	SPEED SWITCH
6	BLK (W9901)	SW BATT FROM PUMP RELAY
7	N/C	
8	N/C	

CN99 (GRAY)

PIN	Color	Description
1	RED	
2	GRN	
3	BLK	
4	YLV	
5	WHT	
6	N/C	
7	N/C	
8	N/C	

AP24154 CN9 (BLACK)

PIN	Color	Description
1	WHT(W7696)	SYSTEM WAKE UP
2	N/C	
3	RED(W6800)	SW BATTERY
4	GRN(W6230)	GROUND
5	CAN SHIELD	
6	RED(W6110)	IGNITION
7	GRN CAN LOW	
8	YEL CAN HI	

AP24154 CN10 (GRAY)

PIN	Color	Description
1	N/C	
2	WHT(W7510)	READY TO OPERATE
3	WHT(W7530)	PUMP
4	WHT(W7501)	EXTEND (ROOM 1)
5	WHT(W7502)	RETRACT (ROOM 1)
6	RED(W6805)	SW BATTERY
7	WHT(W7696)	SYSTEM WAKE UP
8	GRN(W6230)	GROUND

AP24154 CN12 (GRAY)

PIN	Color	Description
1	BLK(W5706)	LOWER FRONT UNLOCK
2	BLK(W5701)	FRONT ROOM OUT
3	N/C	
4	BLK(W5710)	LOWER FRONT LOCK
5	N/C	
6	WHT(W6230)	GROUND
7	RED(W6121)	SW BATTERY
8	N/C	
9	BLK(W5708)	UPPER FRONT LOCK
10	BLK(W5703)	UPPER FRONT ROOM IN
11	BLK(W7695)	PRESS. SW. SYNCH CYLINDER
12	BLK(W5704)	UPPER FRONT UNLOCK

AP24154 CN 11 (GREEN)

PIN	Color	Description
1	BLK(W5707)	LOWER REAR UNLOCK
2	N/C	
3	N/C	
4	BLK(W5711)	LOWER REAR LOCK
5	N/C	
6	N/C	
7	RED(W6120)	SW BATTERY
8	N/C	
9	BLK(W5709)	UPPER REAR LOCK
10	BLK(W5702)	UPPER REAR ROOM IN
11	N/C	
12	BLK(W5705)	UPPER REAR UNLOCK

AP24063
REAR AIR/ROOM 2 MODULE

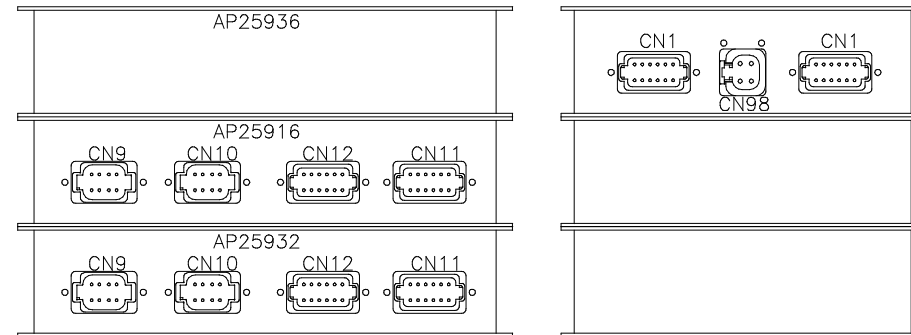

AP22695 CN1 (BROWN)
PIN
1 BLK(W5650) VACUUM
2 BLK(W5600) AIR SEAL
3 N/C
4 N/C
5 N/C
6 N/C
7 N/C
8 N/C
9 N/C
10 N/C
11 WHT(W6245) GROUND
12 N/C

CN98 (GRAY)
PIN
1 RED (W6800) SW BATT
2 RED (W6800) SW BATT
3 GRN (W6230) GND
4 GRN (W6230) GND

AP25148 CN1 (BLACK)
PIN
1 BLK(W3800) TAG LIFT
2 BLK(W4500) LEFT REAR RAISE
3 BLK(W4600) LEFT REAR LOWER
4 BLK(W3500) RIGHT REAR RAISE
5 BLK(W3600) RIGHT REAR LOWER
6 N/C
7 BLK(W3701) TAG TRAVEL
8 BLK(W3700) TRAVEL
9 BLK(W3601) TAG RIGHT LOWER
10 BLK(W4601) TAG LEFT LOWER
11 WHT(W6258) GROUND
12 N/C

AP22698 CN9 (BLACK)
PIN
1 N/C
2 N/C
3 N/C
4 N/C
5 N/C
6 N/C
7 N/C
8 N/C

AP22698 CN10 (GRAY)
PIN
1 N/C
2 N/C
3 N/C
4 N/C
5 N/C
6 N/C

AP22698 CN12 (GRAY)
PIN
1 N/C
2 N/C
3 BLK (W3215) SYSTEM PRESS SW.
4 N/C
5 N/C
6 WHT (W6235) GROUND
7 N/C
8 N/C
9 N/C
10 N/C
11 N/C
12 N/C

AP22698 CN11 (GREEN)
PIN
1 N/C
2 N/C
3 N/C
4 N/C
5 N/C
6 N/C
7 N/C
8 N/C
9 N/C
10 N/C
11 N/C
12 N/C

AP23963 CN9 (BLACK)
PIN
1 WHT(W7696) SYSTEM WAKE UP
2 N/C
3 RED(W6800) SW BATTERY
4 GRN(W6230) GROUND
5 CAN SHIELD
6 RED(W6110) IGNITION
7 GRN CAN LOW
8 YEL CAN HI

AP23963 CN10 (GRAY)
PIN
1 N/C
2 WHT(W7510) READY TO OPERATE
3 WHT(W7530) PUMP
4 WHT(W7501) EXTEND (ROOM 2)
5 WHT(W7502) RETRACT (ROOM 2)
6 RED(W6805) SW BATTERY
7 WHT(W7696) SYSTEM WAKE UP
8 GRN(W6230) GROUND

AP23963 CN12 (GRAY)
PIN
1 N/C
2 BLK(W5701) FRONT ROOM OUT
3 N/C
4 N/C
5 N/C
6 WHT(W6231) GROUND
7 RED(W6121) SW BATTERY
8 N/C
9 N/C
10 BLK(W5703) UPPER FRONT ROOM IN
11 N/C
12 N/C

AP23963 CN 11 (GREEN)
PIN
1 N/C
2 N/C
3 N/C
4 N/C
5 N/C
6 N/C
7 N/C
8 N/C
9 N/C
10 N/C
11 N/C
12 N/C

NOTE: 120 OHM TERMINATING RESISTOR ON TOUCH PANEL. MEASURE RESISTANCE VALUE ACROSS PINS 7 AND 8 ON THE BLACK 8 PIN CAN CONNECTOR. RESISTANCE WILL READ THE TWO TERMINATING RESISTORS IN PARALLEL.

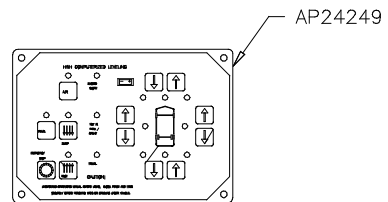

5 1

- PIN
- 1 YELLOW CAN HI
 - 2 GREEN CAN LOW
 - 3 CAN SHIELD
 - 4 GRN (W6230) GROUND
 - 5 RED (W6800) SW. BATTERY

OEM PROVIDED

RIGHT FRONT RAISE

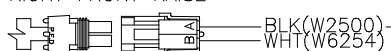

RIGHT FRONT LOWER

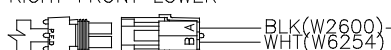

RIGHT FRONT TRAVEL

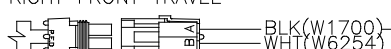

LEFT FRONT TRAVEL



LEFT FRONT LOWER

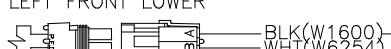

LEFT FRONT RAISE

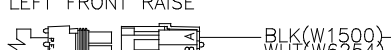

COMPRESSOR

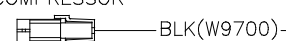

AP24299
FRONT AIR MODULE
SIDE VIEW

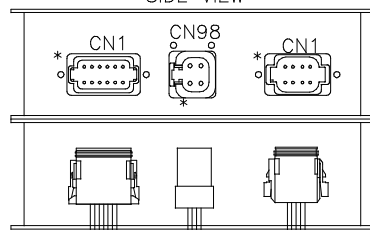

AP24299
FRONT AIR MODULE
FRONT VIEW

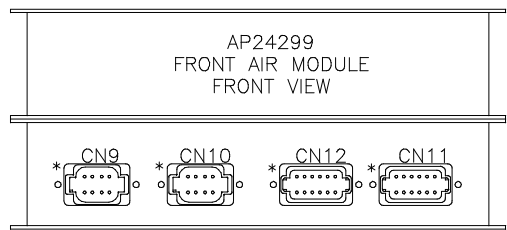

PART OF AP25149

NO CONNECTIONS

PART OF AP25149

LEFT FRONT PRESSURE SWITCH

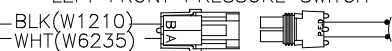

RIGHT FRONT PRESSURE SWITCH

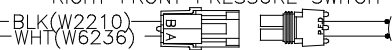

TAG DUMP SWITCH

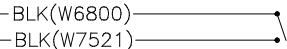

OEM #
62463

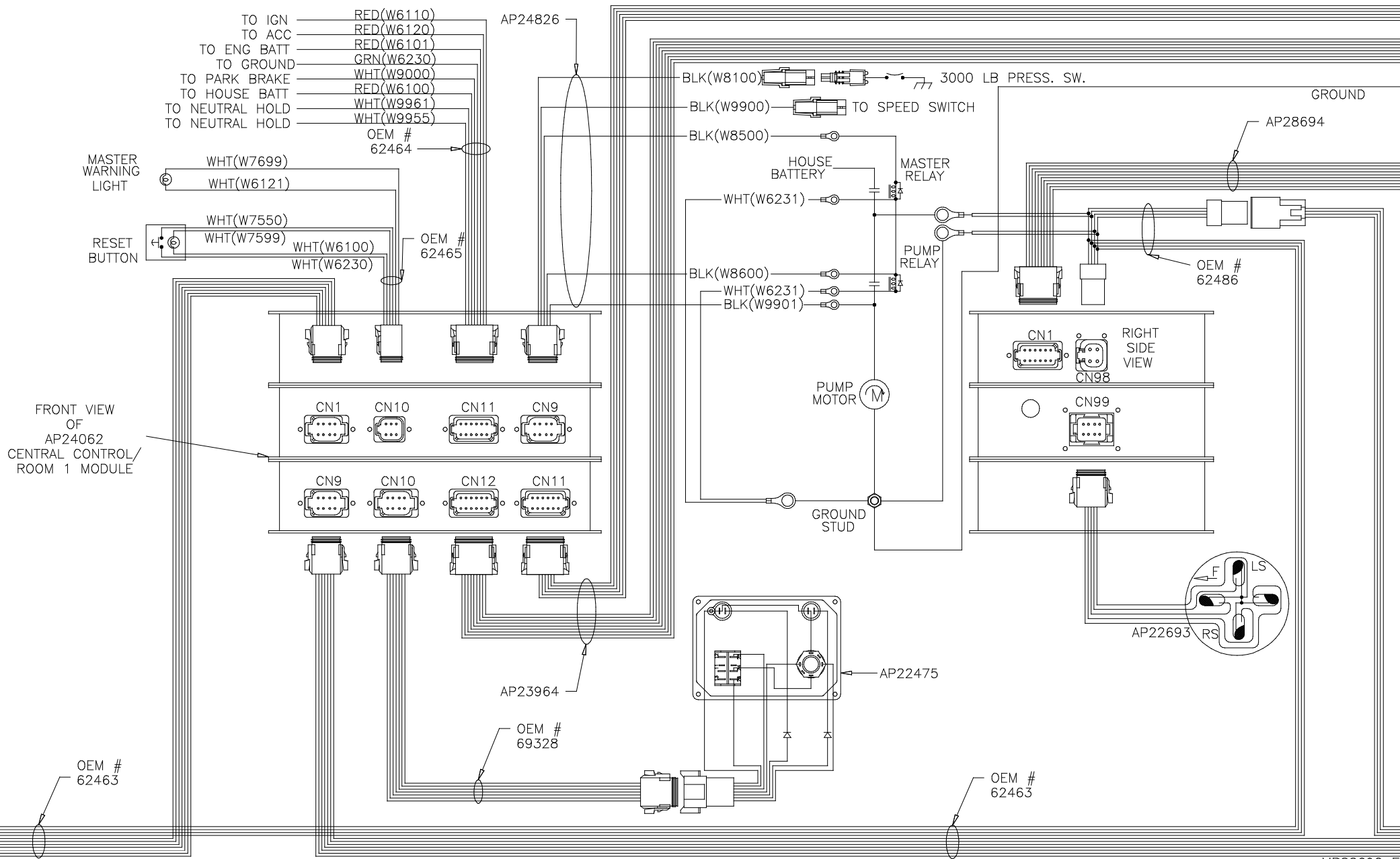

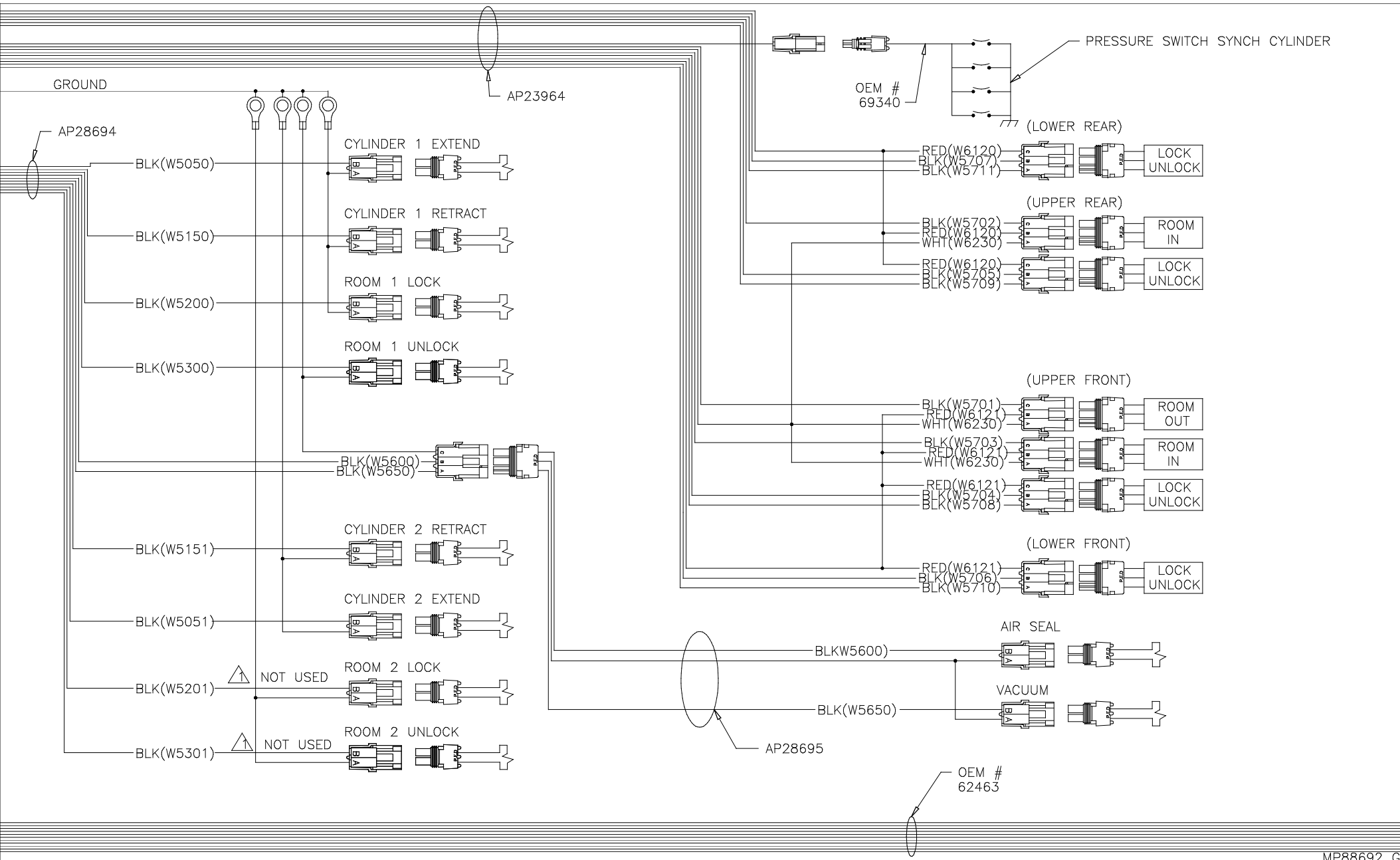

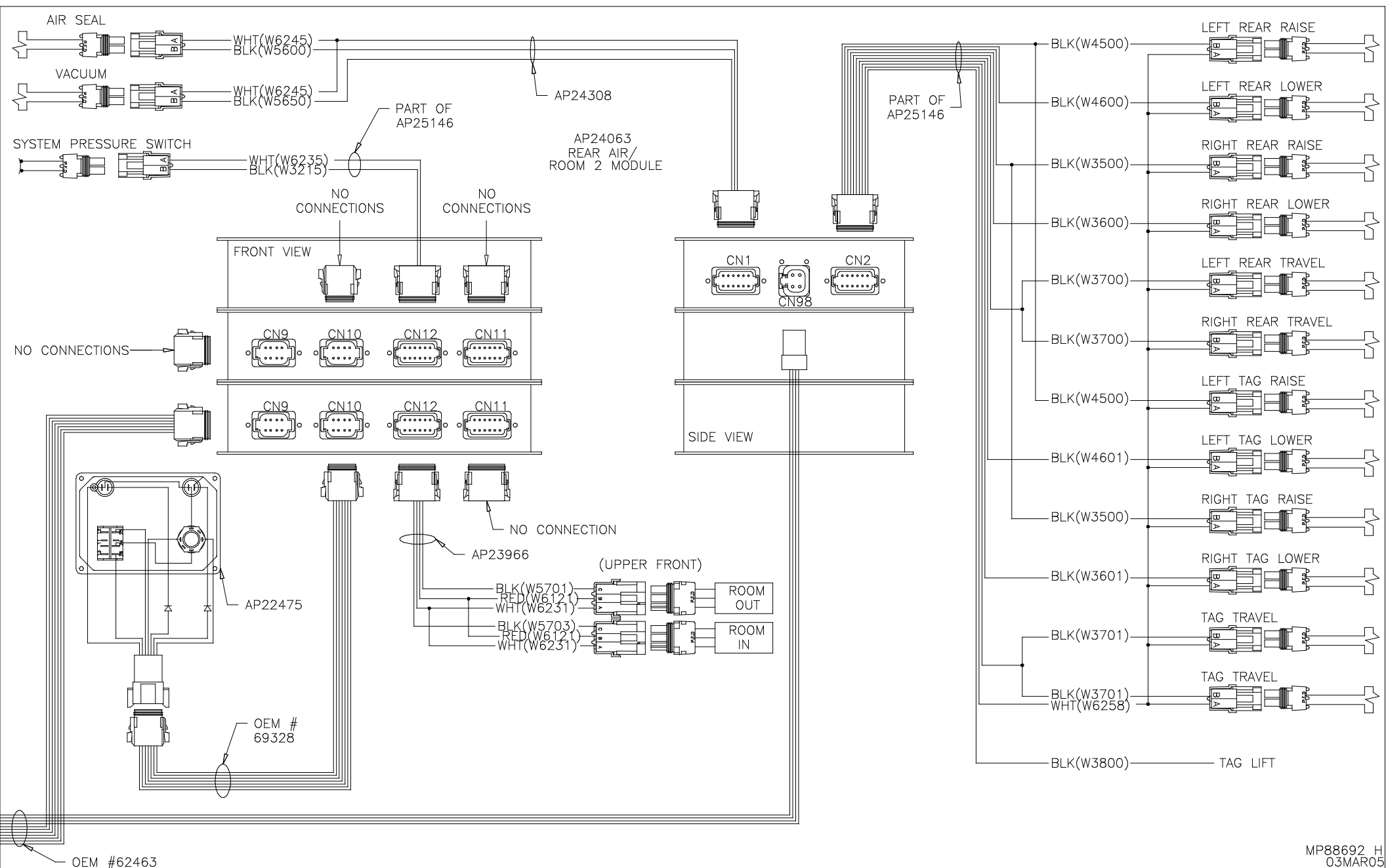

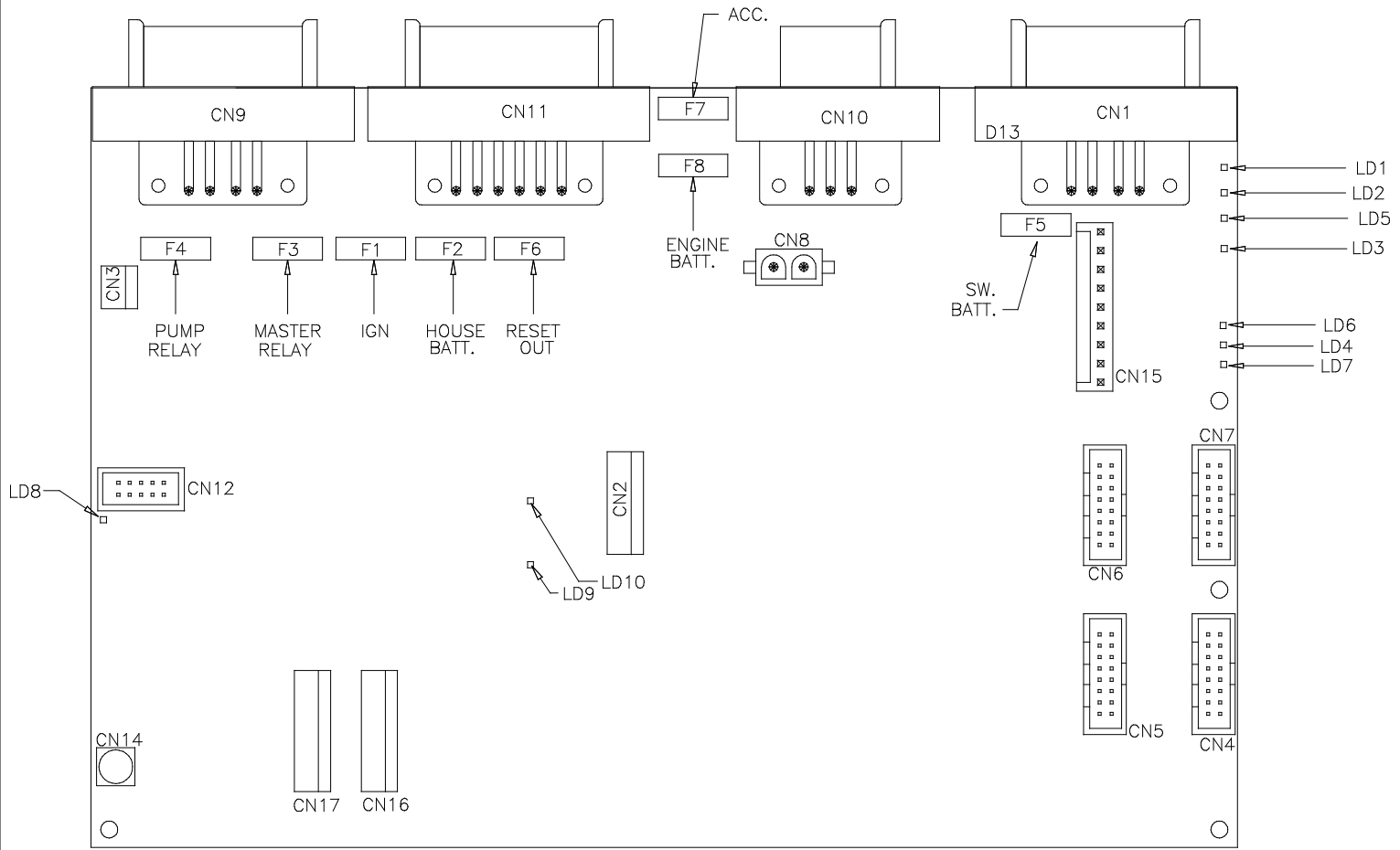

AP22882
CENTRAL
CONTROL MODULE
LED LAYOUT

LED #	CONNECTOR	COLOR	DESCRIPTION
LED 1	CN 9 PIN 1	RED	MASTER RELAY
LED 2	CN 9 PIN 4	RED	PUMP RELAY
LED 3	CN 1 PIN 3	RED	SW 12V
LED 4	CN 11 PIN 12	RED	ENGINE BATT
LED 5	CN 9 PIN 5	RED	SPEED SWITCH
LED 6	NOT USED	NOT USED	NOT USED
LED 7	CN 1 PIN 7 & 8	RED	LINK LIGHT
LED 8	CN 11 PIN 8 & 9	RED	NEUTRAL HOLD
LED 9	NOT USED	NOT USED	NOT USED
LED 10	CN9 PIN 2	RED	3000 LBS. PSW

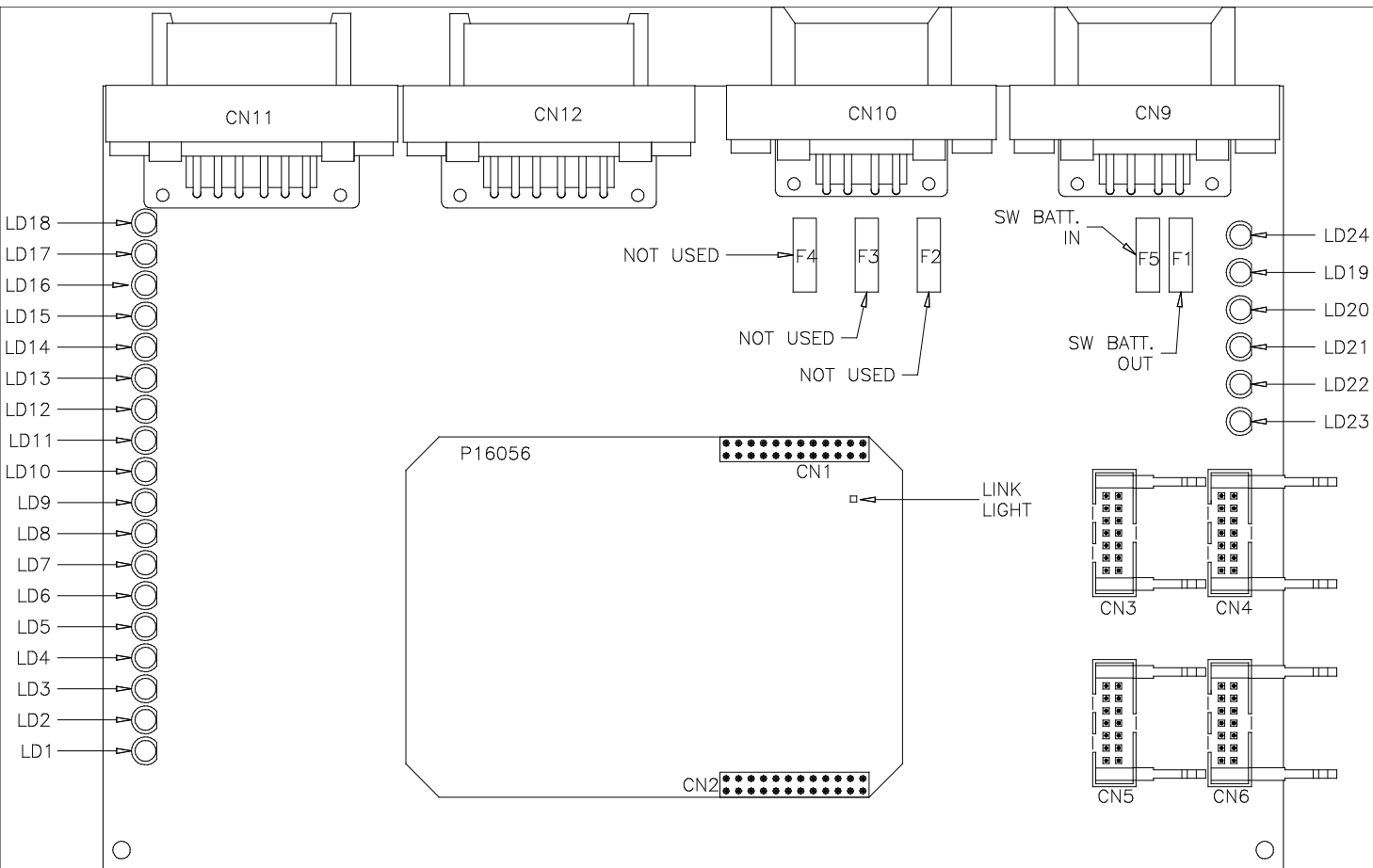

AP22698
FRONT AIR
MODULE
LED LAYOUT

LED #	CONNECTOR	COLOR	DESCRIPTION
LED 1	NOT USED	RED	NOT USED
LED 2	NOT USED	RED	NOT USED
LED 3	NOT USED	GREEN	NOT USED
LED 4	NOT USED	YELLOW	NOT USED
LED 5	NOT USED	YELLOW	NOT USED
LED 6	NOT USED	YELLOW	NOT USED
LED 7	NOT USED	GREEN	NOT USED
LED 8	NOT USED	GREEN	NOT USED
LED 9	CN11 PIN 10	GREEN	LEFT FRONT PSW
LED 10	CN12 PIN 10	GREEN	RIGHT FRONT PSW
LED 11	NOT USED	YELLOW	NOT USED
LED 12	NOT USED	YELLOW	NOT USED
LED 13	NOT USED	YELLOW	NOT USED
LED 14	NOT USED	YELLOW	NOT USED

LED #	CONNECTOR	COLOR	DESCRIPTION
LED 15	NOT USED	GREEN	NOT USED
LED 16	NOT USED	GREEN	NOT USED
LED 17	NOT USED	GREEN	NOT USED
LED 18	NOT USED	GREEN	NOT USED
LED 19	NOT USED	RED	SW BATT OUT
LED 20	NOT USED	RED	SW BATT IN
LED 21	NOT USED	RED	NOT USED
LED 22	NOT USED	RED	NOT USED
LED 23	NOT USED	RED	NOT USED
LED 24	NOT USED	RED	NOT USED
LED 25	---	---	---
LED 26	---	---	---
LED 27	---	---	---
LED 28	---	---	---

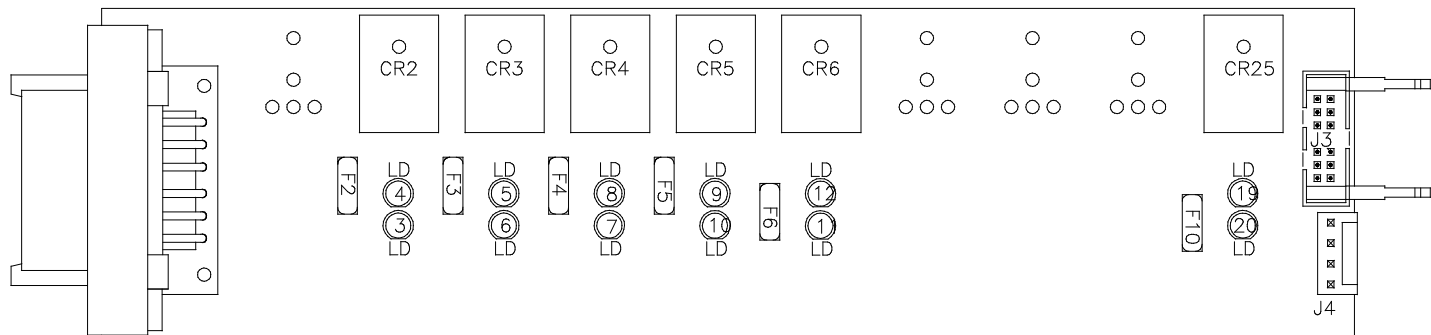

AP22521
FRONT AIR
LED LAYOUT

LED #	COLOR	INPUT J3	FUSE #	OUTPUT	RELAY #	DESCRIPTION
LED1	---	---	---	---	---	---
LED2	---	---	---	---	---	---
LED3	RED	---	FUSE 2	PIN 2	CR2	LEFT RAISE (CONTACT)
LED4	YELLOW	PIN 12	---	---	CR2	LEFT RAISE (COIL)
LED5	YELLOW	PIN 11	---	---	CR3	LEFT LOWER (COIL)
LED6	RED	---	FUSE 3	PIN 3	CR3	LEFT LOWER (CONTACT)
LED7	RED	---	FUSE 4	PIN 4	CR4	RIGHT RAISE (CONTACT)
LED8	YELLOW	PIN 10	---	---	CR4	RIGHT RAISE (COIL)
LED9	YELLOW	PIN 9	---	---	CR5	RIGHT LOWER (COIL)
LED10	RED	---	FUSE 5	PIN 5	CR5	RIGHT LOWER (CONTACT)
LED11	RED	---	FUSE 6	PIN 6	CR6	COMPRESSOR (CONTACT)
LED12	YELLOW	PIN 8	---	---	CR6	COMPRESSOR (COIL)
LED13	---	---	---	---	---	---
LED14	---	---	---	---	---	---
LED15	---	---	---	---	---	---
LED16	---	---	---	---	---	---
LED17	---	---	---	---	---	---
LED18	---	---	---	---	---	---
LED19	YELLOW	PIN 4	---	---	CR25	TRAVEL (COIL)
LED20	RED	---	FUSE 10	PIN 8	CR25	TRAVEL (CONTACT)

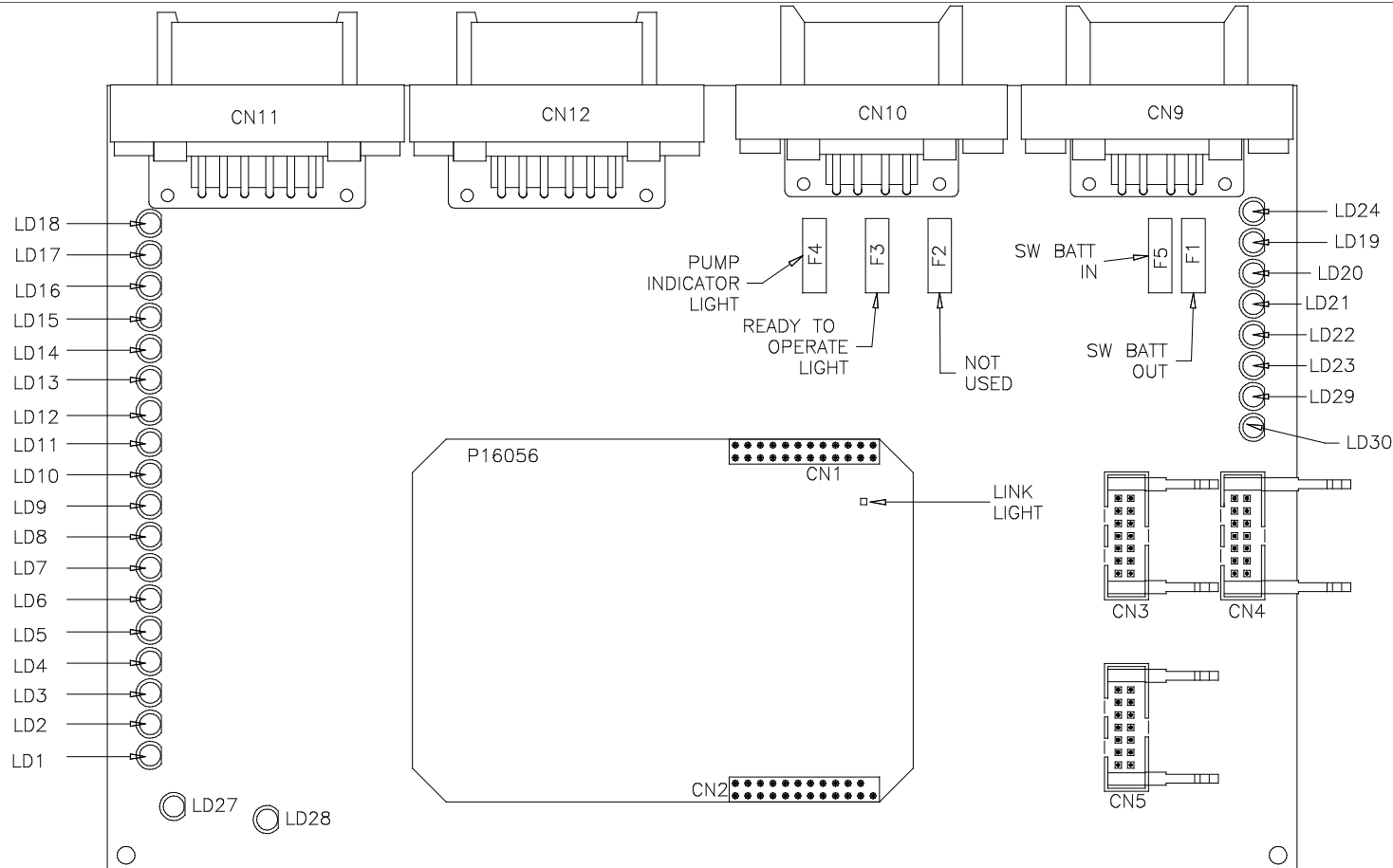

AP24154 ROOM 1
LED LAYOUT

LED #	CONNECTOR	COLOR	DESCRIPTION	LED #	CONNECTOR	COLOR	DESCRIPTION
LED 1	CN10 PIN 4	RED	EXTEND	LED 15	CN11 PIN 4	GREEN	LR LOCK
LED 2	CN11 PIN 5	RED	RETRACT	LED 16	CN12 PIN 4	GREEN	LF LOCK
LED 3	NOT USED	GREEN	NOT USED	LED 17	CN11 PIN 9	GREEN	UR LOCK
LED 4	NOT USED	YELLOW	NOT USED	LED 18	CN12 PIN 9	GREEN	UF LOCK
LED 5	NOT USED	YELLOW	NOT USED	LED 19	CN11/CN12 PIN 7	RED	SW 12V
LED 6	CN12 PIN 2	YELLOW	FRONT RM OUT	LED 20	CN9 PIN 3	RED	SW BATT
LED 7	NOT USED	GREEN	NOT USED	LED 21	CN10 PIN 3	RED	PUMP INDICATOR
LED 8	NOT USED	GREEN	NOT USED	LED 22	CN10 PIN 2	RED	READY TO OPERATE
LED 9	CN11 PIN 10	GREEN	UR ROOM IN	LED 23	NOT USED	RED	NOT USED
LED 10	CN12 PIN 10	GREEN	UF ROOM IN	LED 24	CN10 PIN 7	RED	SYSTEM WAKE UP
LED 11	CN11 PIN 1	YELLOW	LR UNLOCK	LED 27	NOT USED	RED	NOT USED
LED 12	CN12 PIN 1	YELLOW	LF UNLOCK	LED 28	CN12 PIN 11	RED	PSW SYNC CYL
LED 13	CN11 PIN 12	YELLOW	UR UNLOCK	LED 29	---	RED	---
LED 14	CN12 PIN 12	YELLOW	UF UNLOCK	LED 30	NOT USED	RED	NOT USED

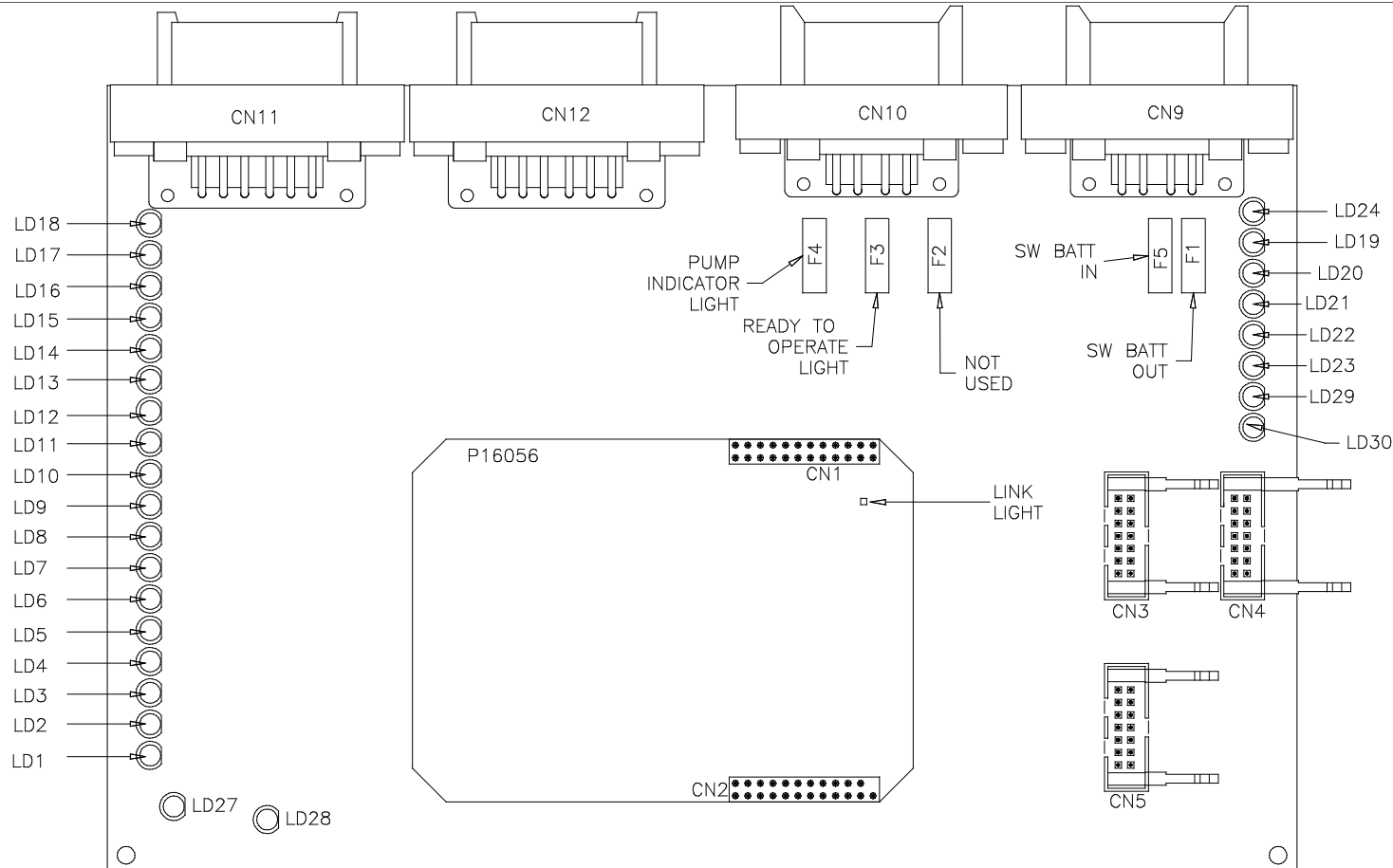

AP23963 ROOM 2
LED LAYOUT

LED #	CONNECTOR	COLOR	DESCRIPTION	LED #	CONNECTOR	COLOR	DESCRIPTION
LED 1	CN10 PIN 4	RED	EXTEND	LED 15	NOT USED	GREEN	NOT USED
LED 2	CN10 PIN 5	RED	RETRACT	LED 16	NOT USED	GREEN	NOT USED
LED 3	NOT USED	GREEN	NOT USED	LED 17	NOT USED	GREEN	NOT USED
LED 4	NOT USED	YELLOW	NOT USED	LED 18	NOT USED	GREEN	NOT USED
LED 5	NOT USED	YELLOW	NOT USED	LED 19	CN11/CN12 PIN 7	RED	SW 12V
LED 6	CN12 PIN 2	YELLOW	FRONT RM OUT	LED 20	CN9 PIN 3	RED	SW BATT
LED 7	NOT USED	GREEN	NOT USED	LED 21	CN10 PIN 3	RED	PUMP INDICATOR
LED 8	NOT USED	GREEN	NOT USED	LED 22	CN10 PIN 2	RED	READY TO OPERATE
LED 9	NOT USED	GREEN	NOT USED	LED 23	NOT USED	RED	NOT USED
LED 10	CN12 PIN 10	GREEN	UF ROOM IN	LED 24	CN10 PIN 7	RED	SYSTEM WAKE UP
LED 11	NOT USED	YELLOW	NOT USED	LED 27	NOT USED	RED	NOT USED
LED 12	NOT USED	YELLOW	NOT USED	LED 28	NOT USED	RED	NOT USED
LED 13	NOT USED	YELLOW	NOT USED	LED 29	---	RED	---
LED 14	NOT USED	YELLOW	NOT USED	LED 30	NOT USED	RED	NOT USED

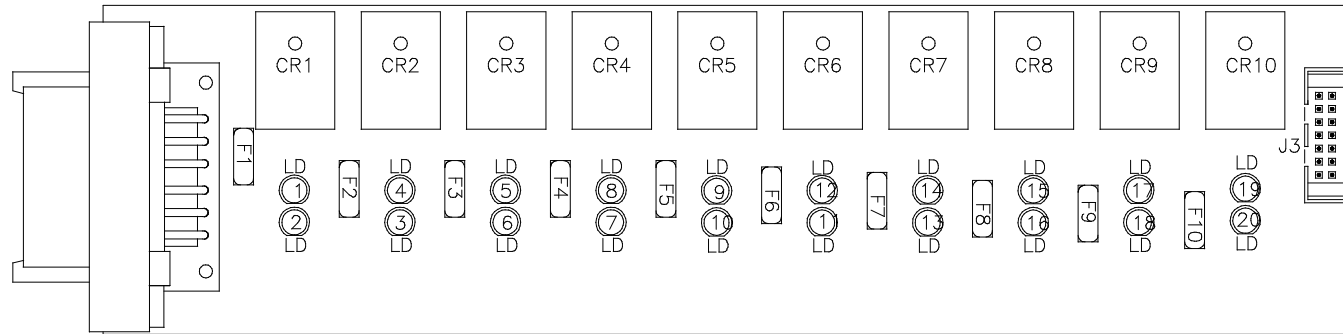

AP23323
ROOM 1 AND ROOM 2
LED LAYOUT

LED #	COLOR	INPUT J3	FUSE #	OUTPUT	RELAY #	DESCRIPTION
LED1	YELLOW	PIN 13	---	---	CR1	EXTEND CYL. RM 1 (COIL)
LED2	RED	---	FUSE 1	PIN 1	CR1	EXTEND CYL. RM 1 (CONTACT)
LED3	RED	---	FUSE 2	PIN 2	CR2	RETRACT CYL. RM 1 (CONTACT)
LED4	YELLOW	PIN 12	---	---	CR2	RETRACT CYL. RM 1 (COIL)
LED5	YELLOW	PIN 11	---	---	CR3	LOCK RM 1 (COIL)
LED6	RED	---	FUSE 3	PIN 3	CR3	LOCK RM 1 (CONTACT)
LED7	RED	---	FUSE 4	PIN 4	CR4	UNLOCK RM 1 (CONTACT)
LED8	YELLOW	PIN 10	---	---	CR4	UNLOCK RM 1 (COIL)
LED9	YELLOW	PIN 9	---	---	CR5	EXTEND CYL. RM 2 (COIL)
LED10	RED	---	FUSE 5	PIN 5	CR5	EXTEND CYL. RM 2 (CONTACT)
LED11	RED	---	FUSE 6	PIN 6	CR6	RETRACT CYL. RM 2 (CONTACT)
LED12	YELLOW	PIN 8	---	---	CR6	RETRACT CYL. RM 2 (COIL)
LED13	---	---	---	---	---	---
LED14	---	---	---	---	---	---
LED15	---	---	---	---	---	---
LED16	---	---	---	---	---	---
LED17	YELLOW	PIN 5	---	---	CR9	AIR SEAL RM 1 (COIL)
LED18	RED	---	FUSE 9	PIN 7	CR9	AIR SEAL RM 1 (CONTACT)
LED19	YELLOW	PIN 4	---	---	CR10	VACUUM RM 1 (COIL)
LED20	RED	---	FUSE 10	PIN 8	CR10	VACUUM RM 1 (CONTACT)



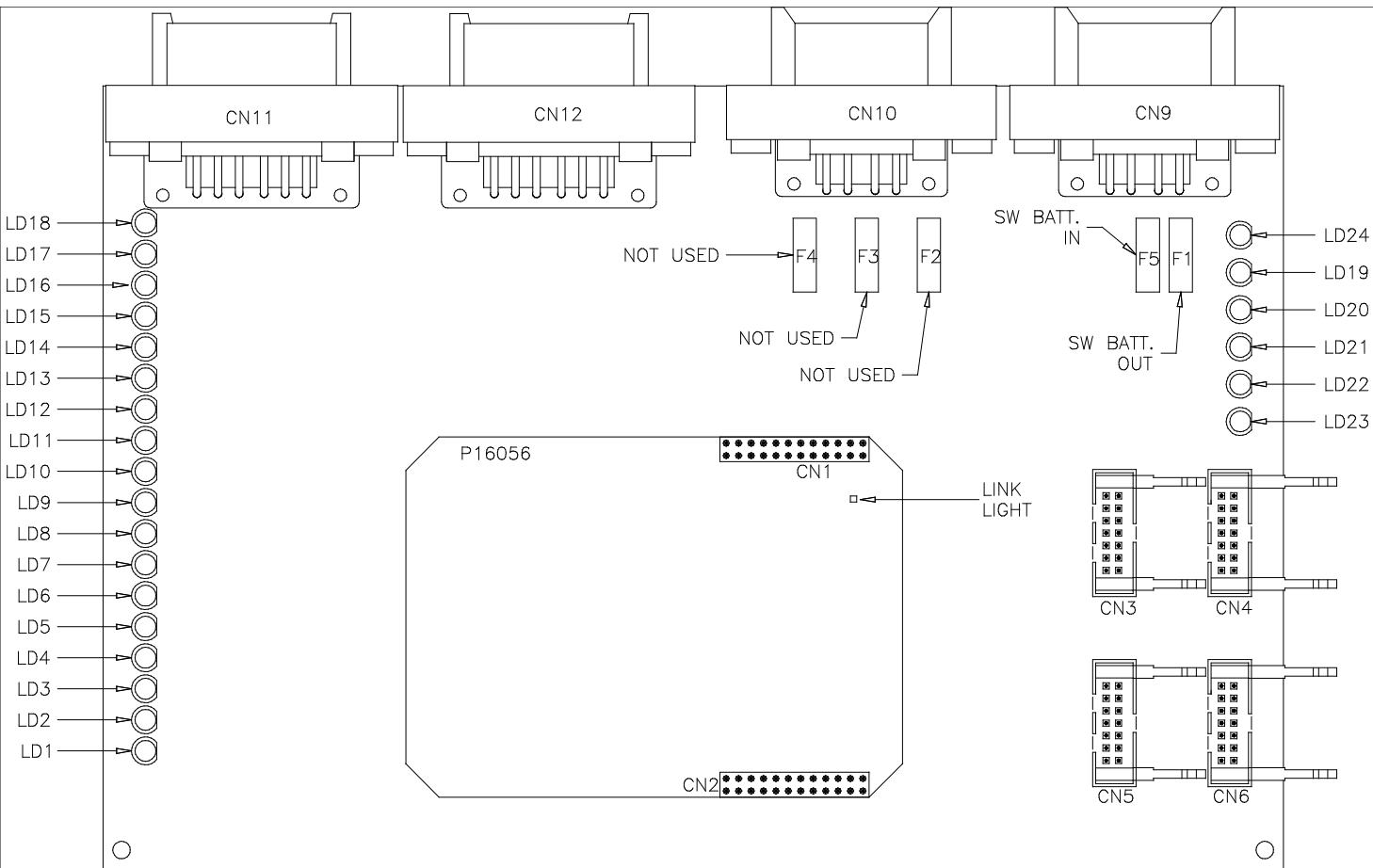

AP22698
REAR AIR
MODULE
LED LAYOUT

LED #	CONNECTOR	COLOR	DESCRIPTION
LED 1	NOT USED	RED	NOT USED
LED 2	NOT USED	RED	NOT USED
LED 3	NOT USED	GREEN	NOT USED
LED 4	NOT USED	YELLOW	NOT USED
LED 5	NOT USED	YELLOW	NOT USED
LED 6	NOT USED	YELLOW	NOT USED
LED 7	NOT USED	GREEN	NOT USED
LED 8	CN 12 PIN 3	GREEN	SYSTEM PRESS SW
LED 9	NOT USED	GREEN	NOT USED
LED 10	NOT USED	GREEN	NOT USED
LED 11	NOT USED	YELLOW	NOT USED
LED 12	NOT USED	YELLOW	NOT USED
LED 13	NOT USED	YELLOW	NOT USED
LED 14	NOT USED	YELLOW	NOT USED

LED #	CONNECTOR	COLOR	DESCRIPTION
LED 15	NOT USED	GREEN	NOT USED
LED 16	NOT USED	GREEN	NOT USED
LED 17	NOT USED	GREEN	NOT USED
LED 18	NOT USED	GREEN	NOT USED
LED 19	NOT USED	RED	SW BATT OUT
LED 20	NOT USED	RED	SW BATT IN
LED 21	NOT USED	RED	NOT USED
LED 22	NOT USED	RED	NOT USED
LED 23	NOT USED	RED	NOT USED
LED 24	NOT USED	RED	NOT USED
LED 25	---	---	---
LED 26	---	---	---
LED 27	---	---	---
LED 28	---	---	---

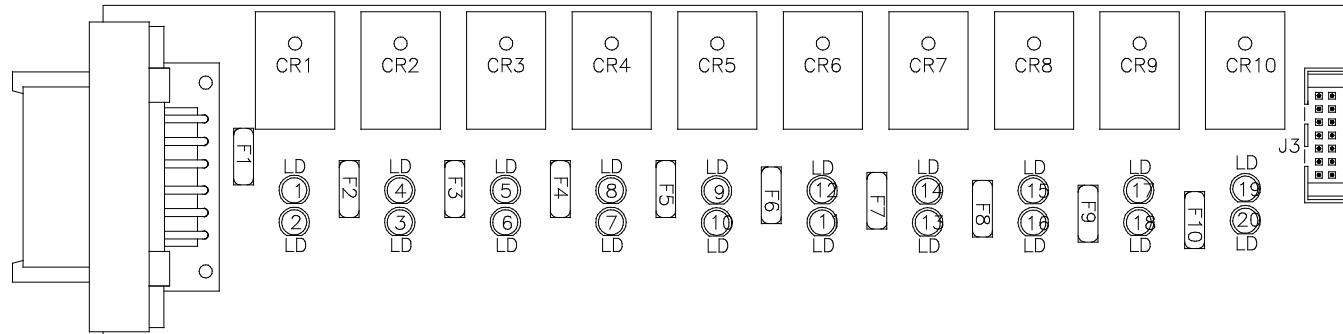

REAR AIR
OUTPUT
LED LAYOUT

LED #	COLOR	INPUT J3	FUSE #	OUTPUT	RELAY #	DESCRIPTION
LED1	YELLOW	PIN 13	---	---	CR1	TAG LIFT (COIL)
LED2	RED	---	FUSE 1	PIN 1	CR1	TAG LIFT (CONTACT)
LED3	RED	---	FUSE 2	PIN 2	CR2	LEFT REAR RAISE (CONTACT)
LED4	YELLOW	PIN 12	---	---	CR2	LEFT REAR RAISE (COIL)
LED5	YELLOW	PIN 11	---	---	CR3	LEFT REAR LOWER (COIL)
LED6	RED	---	FUSE 3	PIN 3	CR3	LEFT REAR LOWER (CONTACT)
LED7	RED	---	FUSE 4	PIN 4	CR4	RIGHT REAR RAISE (CONTACT)
LED8	YELLOW	PIN 10	---	---	CR4	RIGHT REAR RAISE (COIL)
LED9	YELLOW	PIN 9	---	---	CR5	RIGHT REAR LOWER (COIL)
LED10	RED	---	FUSE 5	PIN 5	CR5	RIGHT REAR LOWER (CONTACT)
LED11	RED	---	FUSE 6	PIN 6	CR6	NOT USED
LED12	YELLOW	PIN 8	---	---	CR6	NOT USED
LED13	RED	---	FUSE 7	PIN 10	CR7	TAG LEFT REAR LOWER (CONTACT)
LED14	YELLOW	PIN 7	---	---	CR7	TAG LEFT REAR LOWER (COIL)
LED15	YELLOW	PIN 6	---	---	CR8	TAG RIGHT REAR LOWER (COIL)
LED16	RED	---	FUSE 8	PIN 9	CR8	TAG RIGHT REAR LOWER (CONTACT)
LED17	YELLOW	PIN 5	---	---	CR9	TAG TRAVEL (COIL)
LED18	RED	---	FUSE 9	PIN 7	CR9	TAG TRAVEL (CONTACT)
LED19	YELLOW	PIN 4	---	---	CR10	TRAVEL (COIL)
LED20	RED	---	FUSE 10	PIN 8	CR10	TRAVEL (CONTACT)

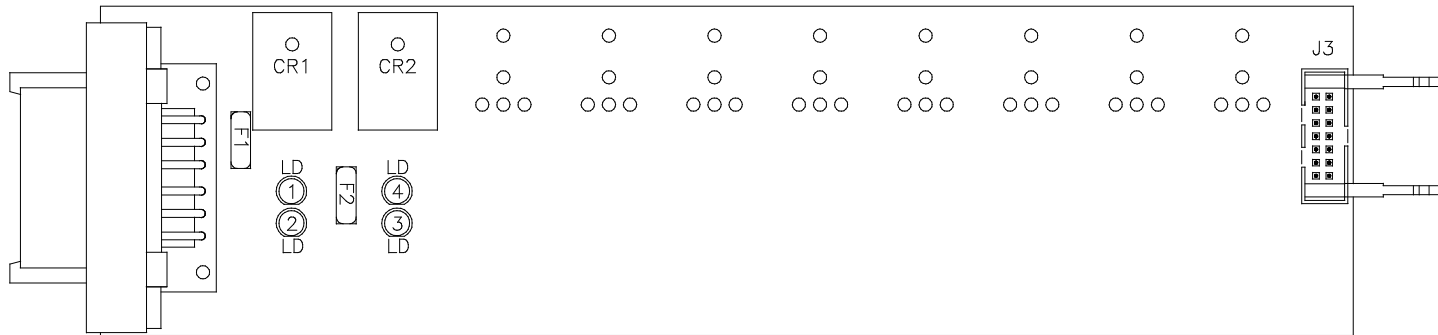

AP22695
ROOM 2
AIR SEAL/VACUUM OUTPUTS
LED LAYOUT

LED #	COLOR	INPUT J3	FUSE #	OUTPUT	RELAY #	DESCRIPTION
LED1	YELLOW	PIN 13	---	---	CR1	AIR SEAL (COIL)
LED2	RED	---	FUSE 1	PIN 1	CR1	AIR SEAL (CONTACT)
LED3	RED	---	FUSE 2	PIN 2	CR2	VACUUM (CONTACT)
LED4	YELLOW	PIN 12	---	---	CR2	VACUUM (COIL)
LED5	---	---	---	---	---	---
LED6	---	---	---	---	---	---
LED7	---	---	---	---	---	---
LED8	---	---	---	---	---	---
LED9	---	---	---	---	---	---
LED10	---	---	---	---	---	---
LED11	---	---	---	---	---	---
LED12	---	---	---	---	---	---
LED13	---	---	---	---	---	---
LED14	---	---	---	---	---	---
LED15	---	---	---	---	---	---
LED16	---	---	---	---	---	---
LED17	---	---	---	---	---	---
LED18	---	---	---	---	---	---
LED19	---	---	---	---	---	---
LED20	---	---	---	---	---	---