

AP25998  
CENTRAL CONTROL MODULE

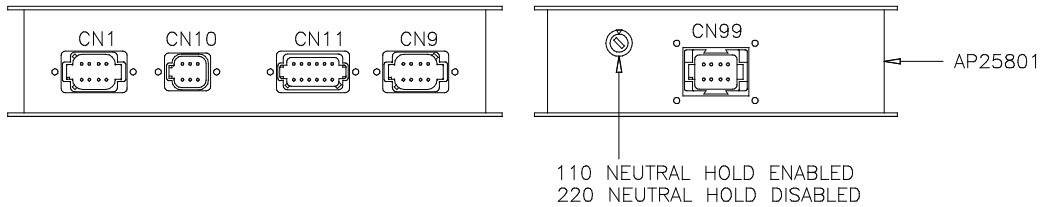

AP25801 CN1 (BLACK)

PIN	DESCRIPTION
1	WHT(W7696) SYSTEM WAKE UP
2	N/C
3	RED(W6800) SW BATT
4	GRN(W6230) GND
5	CAN SHIELD
6	RED(W6110) IGNITION
7	GRN CAN LOW
8	YEL CAN HI

AP25801 CN10 (GRAY)

PIN	DESCRIPTION
1	WHT(W7599) SWITCH LIGHT CONTROL
2	WHT(W6100) RESET OUT
3	WHT(W7550) RESET IN
4	WHT(W6121) WARNING LIGHT SUPPLY
5	WHT(W6230) SWITCH LIGHT SUPPLY
6	WHT(W7699) WARNING LIGHT CONTROL

AP25801 CN11 (GRAY)

PIN	DESCRIPTION
1	RED(W6110) IGNITION
2	N/C
3	N/C
4	N/C
5	RED(W6120) ACCESSORY
6	RED(W6100) HOUSE BATTERY
7	GRN(W6230) GROUND
8	WHT(W9961) NEUTRAL HOLD
9	WHT(W9955) NEUTRAL HOLD
10	N/C
11	WHT(W9000) PARK BRAKE SWITCH
12	RED(W6101) ENGINE BATTERY

AP25801 CN9 (GREEN)

PIN	DESCRIPTION
1	BLK(W8500) MASTER RELAY CNTRL
2	N/C
3	N/C
4	N/C
5	BLK(W9900) SPEED SWITCH
6	N/C
7	N/C
8	N/C

AP25801 CN99 (GRAY)

PIN	DESCRIPTION
1	RED
2	GREEN
3	BLACK
4	YELLOW
5	WHITE
6	N/C
7	N/C
8	N/C

		HWH		I-80 EXIT 267 SOUTH RT 1 MOSCOW, IOWA 52760	
		SCALE 1:3	DATE 18JUL05	DRAWN BY .	
		SYSTEM SCHEMATIC ELEC			
NO.	DATE	REVISION			
THE INFORMATION DISCLOSED ON THIS DRAWING IS CONFIDENTIAL AND MUST NOT BE DISCLOSED OR USED IN ANY MANNER WHICH WILL BE DETRIMENTAL TO THE HWH CORPORATION				DRAWING NUMBER MP88706 A/L	

AP24299  
FRONT AIR MODULE

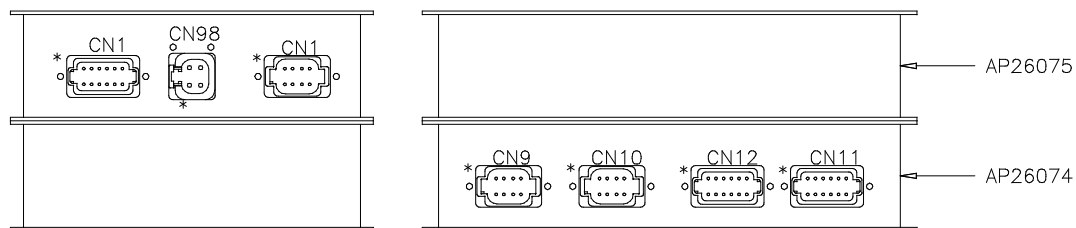

\* DESIGNATES PIN 1 OF CONNECTORS

AP26075 CN1 (BROWN)

PIN	DESCRIPTION
1	N/C
2	BLK(W1500) LEFT FRONT RAISE
3	BLK(W1600) LEFT FRONT LOWER
4	BLK(W2500) RIGHT FRONT RAISE
5	BLK(W2600) RIGHT FRONT LOWER
6	BLK(W9700) COMPRESSOR
7	N/C
8	BLK(W1700) TRAVEL
9	N/C
10	N/C
11	WHT(W6254) GROUND
12	N/C

AP26075 CN98 (GRAY)

PIN	DESCRIPTION
1	RED(W6800) SW BATT
2	RED(W6800) SW BATT
3	GRN(W6230) GND
4	GRN(W6230) GND

AP26075 CN1 (BLACK)

PIN	DESCRIPTION
1	N/C
2	N/C
3	RED(W6800) SW BATTERY
4	GRN(W6230) GROUND
5	CAN SHIELD
6	N/C
7	GRN CAN LOW
8	YEL CAN HI

AP26074 CN9 (BLACK)

PIN	DESCRIPTION
1	WHT(W7696) SYSTEM WAKE UP
2	N/C
3	RED(W6800) SW BATTERY
4	GRN(W6230) GROUND
5	CAN SHIELD
6	RED(W6110) IGNITION
7	GRN CAN LOW
8	YEL CAN HI

AP26074 CN10 (GRAY)

PIN	DESCRIPTION
1	N/C
2	N/C
3	N/C
4	N/C
5	N/C
6	N/C

AP26074 CN12 (GRAY)

PIN	DESCRIPTION
1	N/C
2	N/C
3	N/C
4	N/C
5	N/C
6	WHT(W6236) GROUND
7	N/C
8	N/C
9	N/C
10	BLK(W2210) RIGHT FRONT PSW
11	N/C
12	N/C

AP26074 CN11 (GREEN)

PIN	DESCRIPTION
1	N/C
2	N/C
3	N/C
4	N/C
5	N/C
6	WHT(W6235) GROUND
7	N/C
8	N/C
9	N/C
10	BLK(W1210) LEFT FRONT PSW
11	N/C
12	N/C

AP25150  
REAR AIR MODULE

AP26108 CN1 (BLACK)

PIN	DESCRIPTION
1	N/C
2	BLK(W4500) LEFT REAR RAISE
3	BLK(W4600) LEFT REAR LOWER
4	BLK(W3500) RIGHT REAR RAISE
5	BLK(W3600) RIGHT REAR LOWER
6	N/C
7	N/C
8	BLK(W3700) TRAVEL
9	N/C
10	N/C
11	WHT(W6258) GROUND
12	N/C

AP26108 CN98 (GRAY)

PIN	DESCRIPTION
1	RED(W6800) SW BATT
2	RED(W6800) SW BATT
3	GRN(W6230) GND
4	GRN(W6230) GND

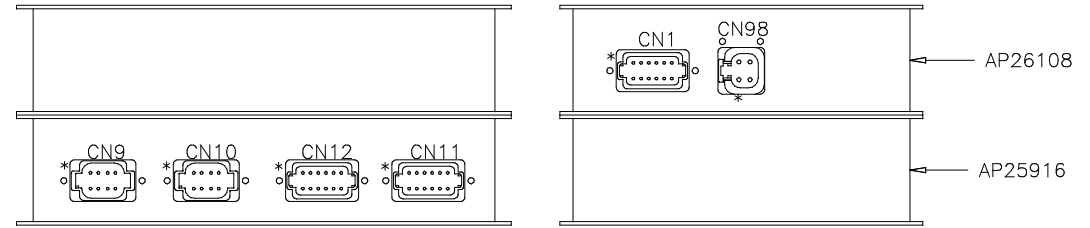

\* DESIGNATES PIN 1 OF CONNECTORS

AP25916 CN9 (BLACK)

PIN	DESCRIPTION
1	WHT(W7696) SYSTEM WAKE UP
2	N/C
3	RED(W6800) SW. BATTERY
4	GRN(W6230) GROUND
5	CAN SHIELD
6	RED(W6110) IGNITION
7	GRN CAN LOW
8	YEL CAN HI

AP25916 CN10 (GRAY)

PIN	DESCRIPTION
1	N/C
2	N/C
3	N/C
4	N/C
5	N/C
6	N/C

AP25916 CN12 (GRAY)

PIN	DESCRIPTION
1	N/C
2	N/C
3	BLK(W3215) SYSTEM PRESS SW.
4	N/C
5	N/C
6	WHT(W6235) GROUND
7	N/C
8	N/C
9	N/C
10	N/C
11	N/C
12	N/C

AP25916 CN11 (GREEN)

PIN	DESCRIPTION
1	N/C
2	N/C
3	N/C
4	N/C
5	N/C
6	N/C
7	N/C
8	N/C
9	N/C
10	N/C
11	N/C
12	N/C

NOTE: 120 OHM TERMINATING RESISTOR ON TOUCH PANEL. MEASURE RESISTANCE VALUE ACROSS PINS 7 AND 8 ON THE BLACK 8 PIN CAN CONNECTOR. RESISTANCE WILL READ THE TWO TERMINATING RESISTORS IN PARALLEL.

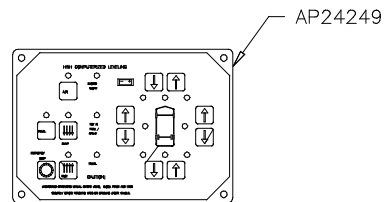

5 1

- PIN
- 1 YELLOW CAN HI
  - 2 GREEN CAN LOW
  - 3 CAN SHIELD
  - 4 GRN(W6230) GROUND
  - 5 RED(W6800) SW. BATTERY

OEM #  
62463

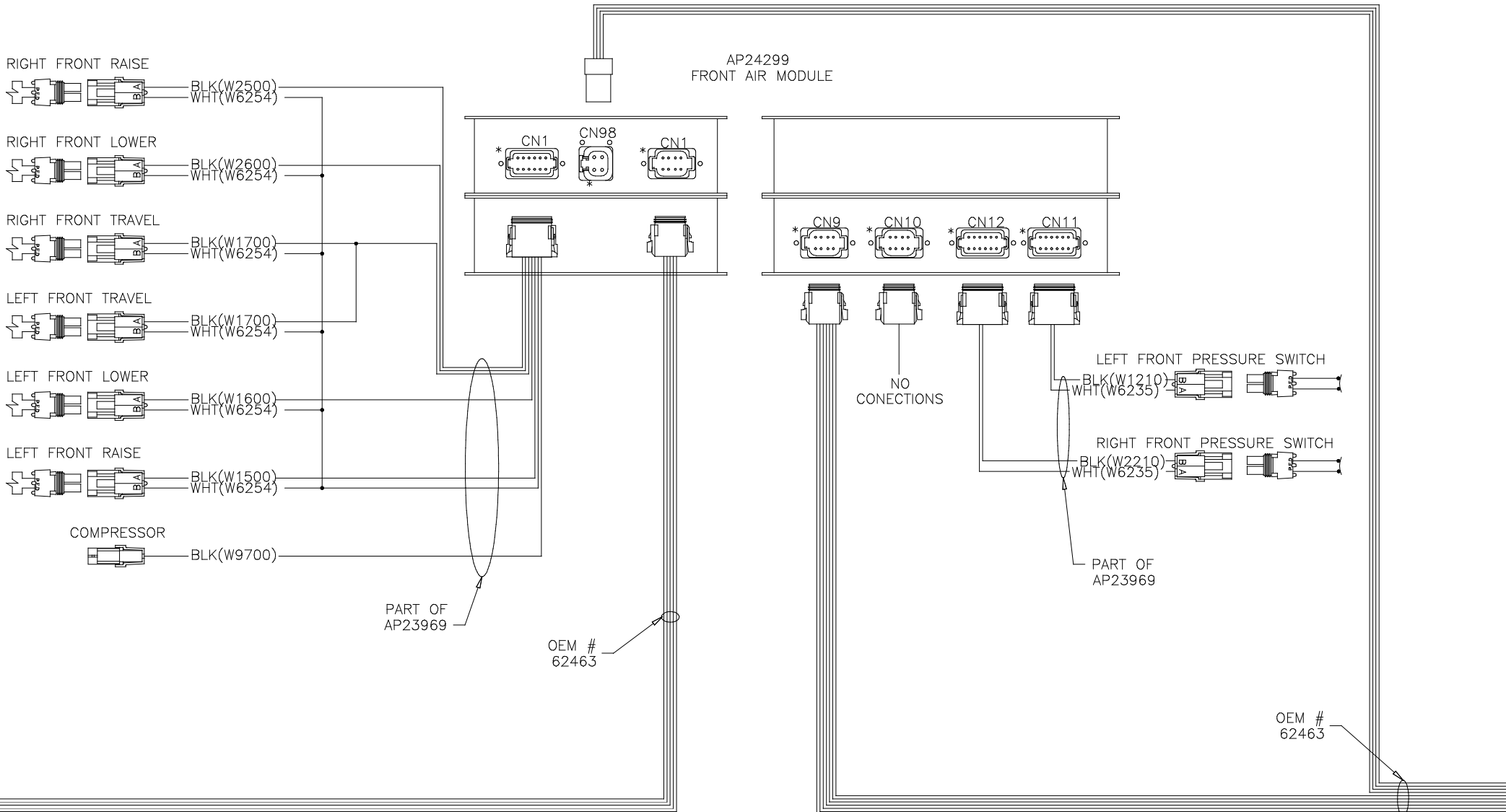

- TO IGNITION — RED(W6110)
- TO ACCESSORY — RED(W6120)
- TO ENGINE BATTERY — RED(W6101)
- TO GROUND — GRN(W6230)
- TO PARK BRAKE — WHT(W9000)
- TO HOUSE BATTERY — RED(W6100)
- TO NEUTRAL HOLD — WHT(W9961)
- TO NEUTRAL HOLD — WHT(W9955)

OEM # 62464

MASTER WARNING LIGHT

RESET BUTTON

OEM # 62465

AP26071

BLK(W9900) — TO SPEED SWITCH

BLK(W8500)

HOUSE BATTERY — MASTER RELAY

20 AMP FUSE

WHT(W6231)

WHT(W6800)

GROUND STUD

GRN(W6230)

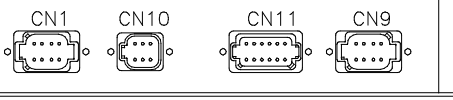

FRONT VIEW  
AP25998  
CENTRAL CONTROL MODULE

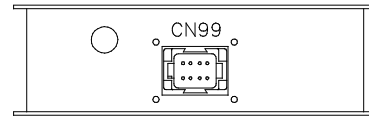

RIGHT SIDE VIEW

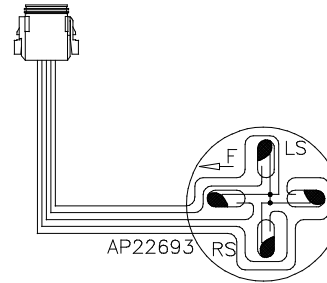

AP22693

OEM # 62463

OEM # 62463

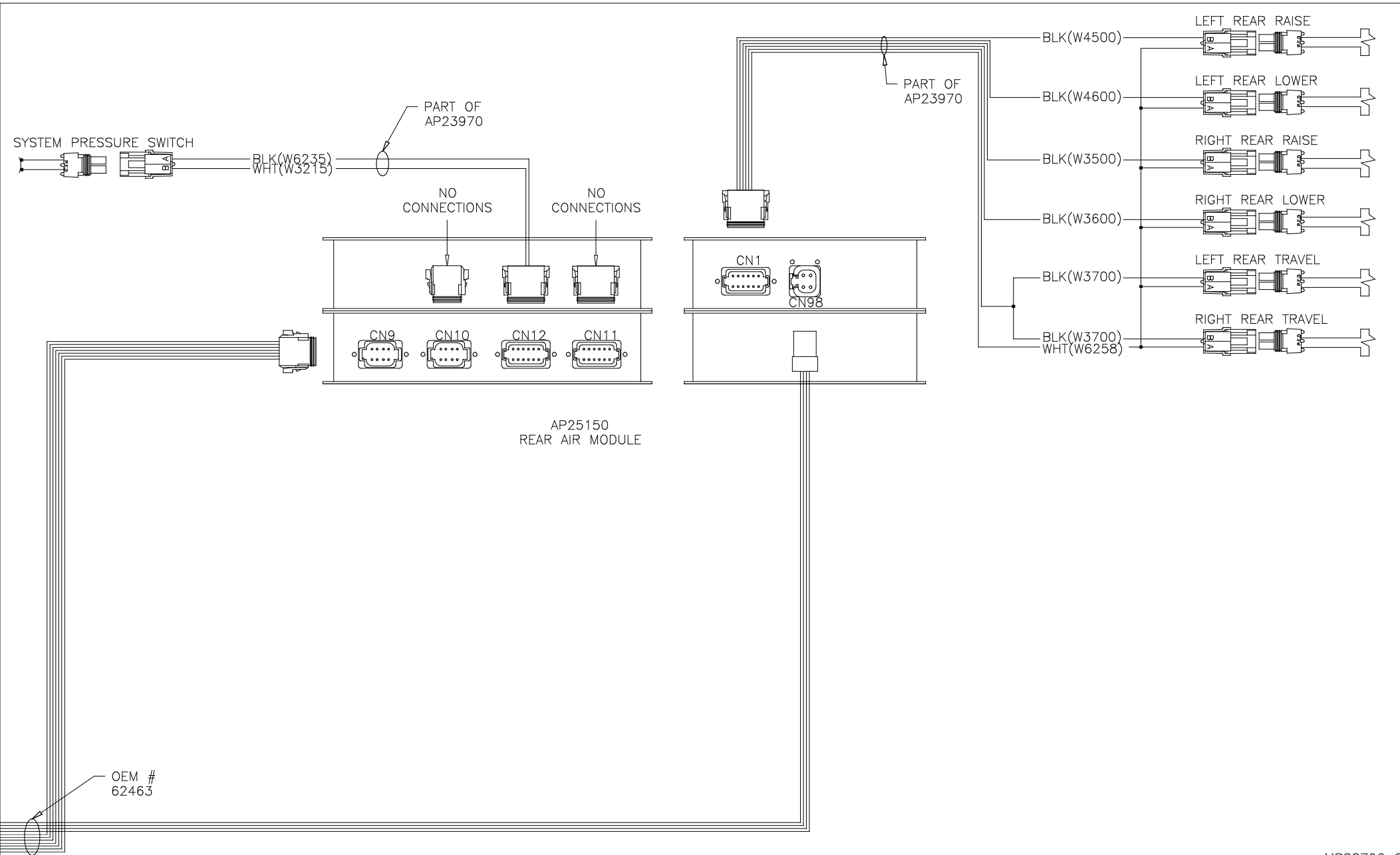

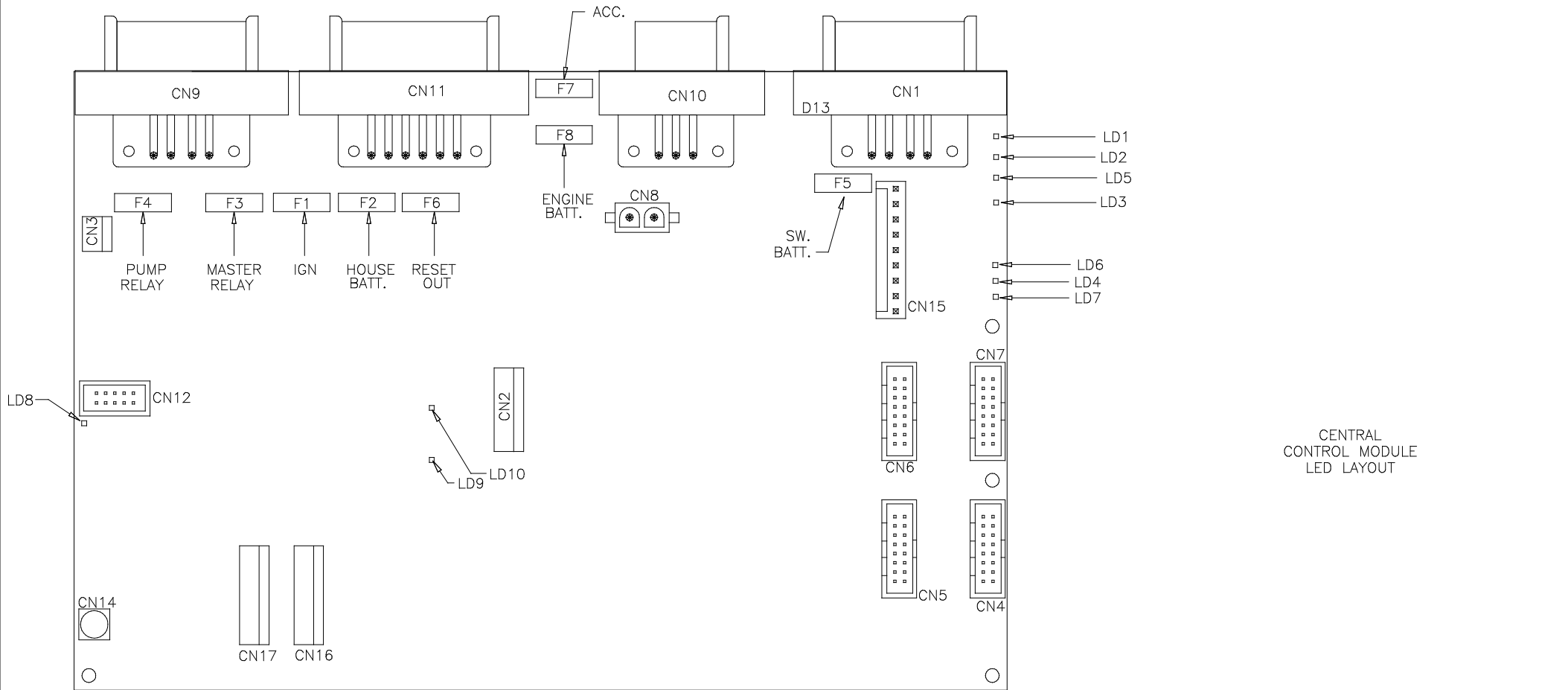

LED #	CONNECTOR	COLOR	DESCRIPTION
LED 1	CN 9 PIN 1	RED	MASTER RELAY
LED 2	NOT USED	RED	NOT USED
LED 3	CN 1 PIN 3	RED	SW 12V
LED 4	CN 11 PIN 12	RED	ENGINE BATT
LED 5	CN 9 PIN 5	RED	SPEED SWITCH
LED 6	NOT USED	NOT USED	NOT USED
LED 7	CN 1 PIN 7 & 8	RED	LINK LIGHT
LED 8	CN 11 PIN 8 & 9	RED	NEUTRAL HOLD
LED 9	NOT USED	NOT USED	NOT USED
LED 10	NOT USED	RED	NOT USED



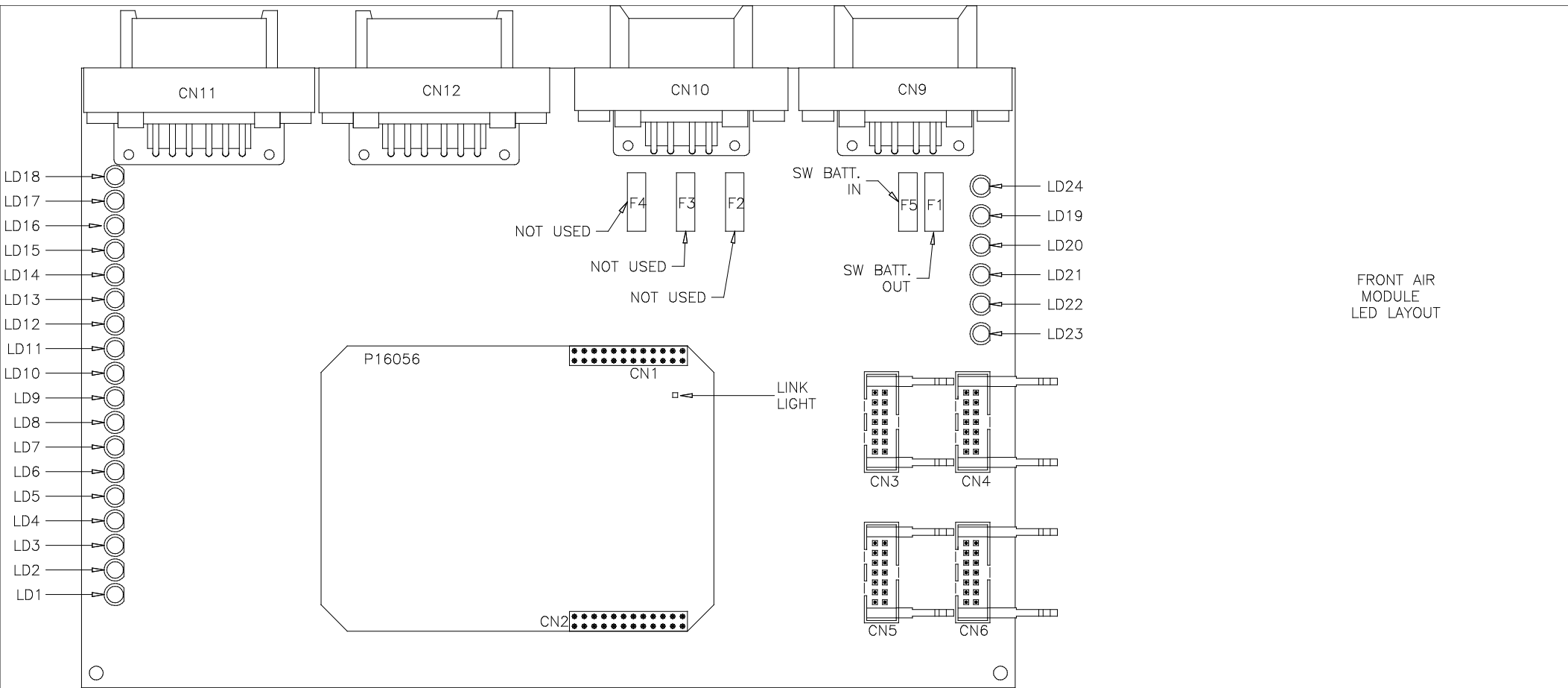

FRONT AIR  
MODULE  
LED LAYOUT

LED #	CONNECTOR	COLOR	DESCRIPTION
LED 1	NOT USED	RED	NOT USED
LED 2	NOT USED	RED	NOT USED
LED 3	NOT USED	GREEN	NOT USED
LED 4	NOT USED	YELLOW	NOT USED
LED 5	NOT USED	YELLOW	NOT USED
LED 6	NOT USED	YELLOW	NOT USED
LED 7	NOT USED	GREEN	NOT USED
LED 8	NOT USED	GREEN	NOT USED
LED 9	CN 11 PIN 10	GREEN	LEFT FRONT PSW
LED 10	CN 12 PIN 10	GREEN	RIGHT FRONT PSW
LED 11	NOT USED	YELLOW	NOT USED
LED 12	NOT USED	YELLOW	NOT USED
LED 13	NOT USED	YELLOW	NOT USED
LED 14	NOT USED	YELLOW	NOT USED

LED #	CONNECTOR	COLOR	DESCRIPTION
LED 15	NOT USED	GREEN	NOT USED
LED 16	NOT USED	GREEN	NOT USED
LED 17	NOT USED	GREEN	NOT USED
LED 18	NOT USED	GREEN	NOT USED
LED 19	NOT USED	RED	SW BATT OUT
LED 20	NOT USED	RED	SW BATT IN
LED 21	NOT USED	RED	NOT USED
LED 22	NOT USED	RED	NOT USED
LED 23	NOT USED	RED	NOT USED
LED 24	NOT USED	RED	NOT USED
LED 25	---	---	---
LED 26	---	---	---
LED 27	---	---	---
LED 28	---	---	---

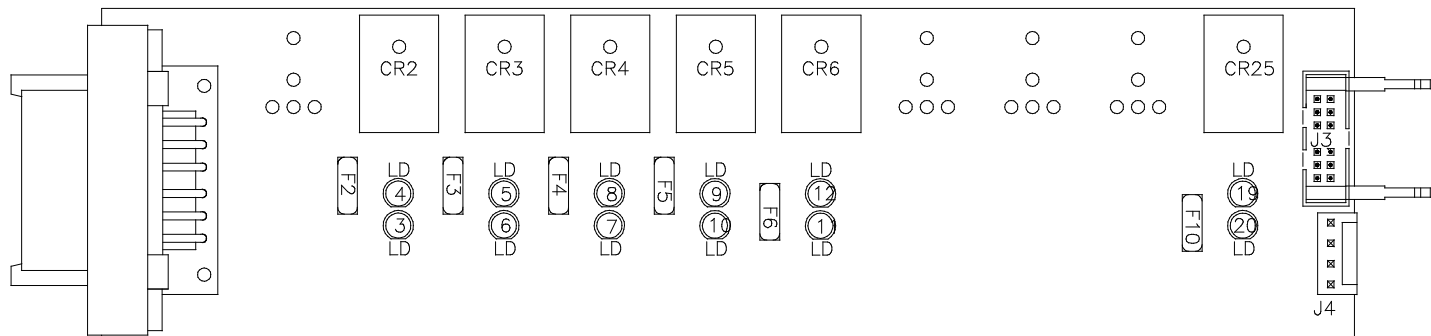

FRONT AIR  
OUTPUT  
LED LAYOUT

LED #	COLOR	INPUT J3	FUSE #	OUTPUT	RELAY #	DESCRIPTION
LED1	---	---	---	---	---	---
LED2	---	---	---	---	---	---
LED3	RED	---	FUSE 2	PIN 2	CR2	LEFT FRONT RAISE (CONTACT)
LED4	YELLOW	PIN 12	---	---	CR2	LEFT FRONT RAISE (COIL)
LED5	YELLOW	PIN 11	---	---	CR3	LEFT FRONT LOWER (COIL)
LED6	RED	---	FUSE 3	PIN 3	CR3	LEFT FRONT LOWER (CONTACT)
LED7	RED	---	FUSE 4	PIN 4	CR4	RIGHT FRONT RAISE (CONTACT)
LED8	YELLOW	PIN 10	---	---	CR4	RIGHT FRONT RAISE (COIL)
LED9	YELLOW	PIN 9	---	---	CR5	RIGHT FRONT LOWER (COIL)
LED10	RED	---	FUSE 5	PIN 5	CR5	RIGHT FRONT LOWER (CONTACT)
LED11	RED	---	FUSE 6	PIN 6	CR6	COMPRESSOR (CONTACT)
LED12	YELLOW	PIN 8	---	---	CR6	COMPRESSOR (COIL)
LED13	---	---	---	---	---	---
LED14	---	---	---	---	---	---
LED15	---	---	---	---	---	---
LED16	---	---	---	---	---	---
LED17	---	---	---	---	---	---
LED18	---	---	---	---	---	---
LED19	YELLOW	PIN 4	---	---	CR25	TRAVEL (COIL)
LED20	RED	---	FUSE 10	PIN 8	CR25	TRAVEL (CONTACT)

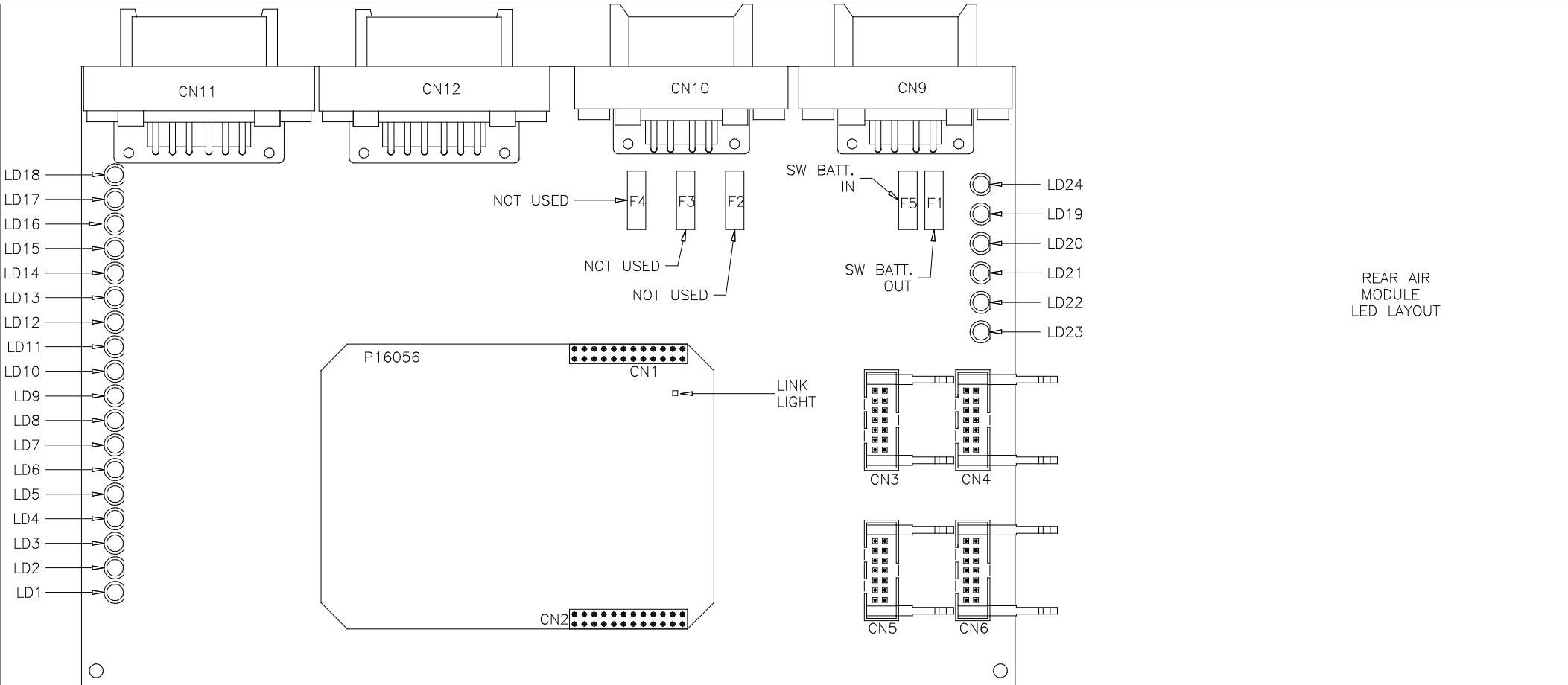

REAR AIR  
MODULE  
LED LAYOUT

LED #	CONNECTOR	COLOR	DESCRIPTION
LED 1	NOT USED	RED	NOT USED
LED 2	NOT USED	RED	NOT USED
LED 3	NOT USED	GREEN	NOT USED
LED 4	NOT USED	YELLOW	NOT USED
LED 5	NOT USED	YELLOW	NOT USED
LED 6	NOT USED	YELLOW	NOT USED
LED 7	NOT USED	GREEN	NOT USED
LED 8	CN 12 PIN 3	GREEN	SYSTEM PRESS SW
LED 9	NOT USED	GREEN	NOT USED
LED 10	NOT USED	GREEN	NOT USED
LED 11	NOT USED	YELLOW	NOT USED
LED 12	NOT USED	YELLOW	NOT USED
LED 13	NOT USED	YELLOW	NOT USED
LED 14	NOT USED	YELLOW	NOT USED

LED #	CONNECTOR	COLOR	DESCRIPTION
LED 15	NOT USED	GREEN	NOT USED
LED 16	NOT USED	GREEN	NOT USED
LED 17	NOT USED	GREEN	NOT USED
LED 18	NOT USED	GREEN	NOT USED
LED 19	NOT USED	RED	SW BATT OUT
LED 20	NOT USED	RED	SW BATT IN
LED 21	NOT USED	RED	NOT USED
LED 22	NOT USED	RED	NOT USED
LED 23	NOT USED	RED	NOT USED
LED 24	NOT USED	RED	NOT USED
LED 25	---	---	---
LED 26	---	---	---
LED 27	---	---	---
LED 28	---	---	---

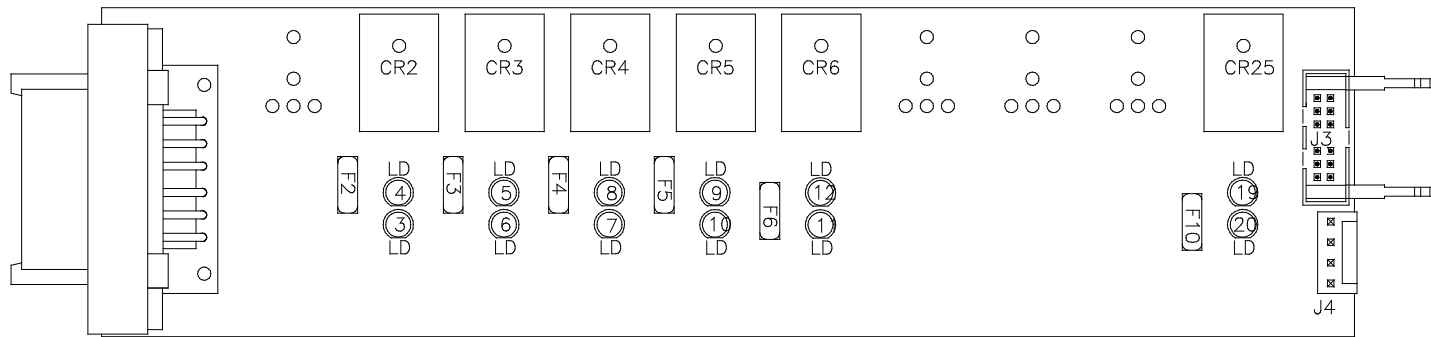

REAR AIR  
OUTPUT  
LED LAYOUT

LED #	COLOR	INPUT J3	FUSE #	OUTPUT	RELAY #	DESCRIPTION
LED1	---	---	---	---	---	---
LED2	---	---	---	---	---	---
LED3	RED	---	FUSE 2	PIN 2	CR2	LEFT REAR RAISE (CONTACT)
LED4	YELLOW	PIN 12	---	---	CR2	LEFT REAR RAISE (COIL)
LED5	YELLOW	PIN 11	---	---	CR3	LEFT REAR LOWER (COIL)
LED6	RED	---	FUSE 3	PIN 3	CR3	LEFT REAR LOWER (CONTACT)
LED7	RED	---	FUSE 4	PIN 4	CR4	RIGHT REAR RAISE (CONTACT)
LED8	YELLOW	PIN 10	---	---	CR4	RIGHT REAR RAISE (COIL)
LED9	YELLOW	PIN 9	---	---	CR5	RIGHT REAR LOWER (COIL)
LED10	RED	---	FUSE 5	PIN 5	CR5	RIGHT REAR LOWER (CONTACT)
LED11	RED	---	FUSE 6	PIN 6	CR6	COMPRESSOR (CONTACT)
LED12	YELLOW	PIN 8	---	---	CR6	COMPRESSOR (COIL)
LED13	---	---	---	---	---	---
LED14	---	---	---	---	---	---
LED15	---	---	---	---	---	---
LED16	---	---	---	---	---	---
LED17	---	---	---	---	---	---
LED18	---	---	---	---	---	---
LED19	YELLOW	PIN 4	---	---	CR25	TRAVEL (COIL)
LED20	RED	---	FUSE 10	PIN 8	CR25	TRAVEL (CONTACT)