

AP24299
FRONT AIR MODULE

* DESIGNATES PIN 1 OF CONNECTORS

AP26075 (BROWN)

- PIN
- 1 N/C
 - 2 BLK(W1500) LEFT FRONT RAISE
 - 3 BLK(W1600) LEFT FRONT LOWER
 - 4 BLK(W2500) RIGHT FRONT RAISE
 - 5 BLK(W2600) RIGHT FRONT LOWER
 - 6 BLK(W9700) COMPRESSOR
 - 7 N/C
 - 8 BLK(W1700) TRAVEL
 - 9 N/C
 - 10 N/C
 - 11 WHT(W6254) GROUND
 - 12 N/C

AP26075 (GRAY)

- PIN
- 1 RED(W6800) SW BATT
 - 2 RED(W6800) SW BATT
 - 3 GRN(W6230) GND
 - 4 GRN(W6230) GND

AP26075 (BLACK)

- PIN
- 1 N/C
 - 2 N/C
 - 3 RED(W6800) SW BATTERY
 - 4 GRN(W6230) GROUND
 - 5 CAN SHIELD
 - 6 N/C
 - 7 GRN CAN LOW
 - 8 YEL CAN HI

AP26074 CN9(BLACK)

- PIN
- 1 WHT(W7696) SYSTEM WAKE UP
 - 2 N/C
 - 3 RED(W6800) SW BATTERY
 - 4 GRN(W6230) GROUND
 - 5 CAN SHIELD
 - 6 RED(W6110) IGNITION
 - 7 GRN CAN LOW
 - 8 YEL CAN HI

AP26074 CN10(GRAY)

- PIN
- 1 N/C
 - 2 N/C
 - 3 N/C
 - 4 N/C
 - 5 N/C
 - 6 N/C
 - 7 N/C
 - 8 N/C

AP26074 CN12(GRAY)

- PIN
- 1 N/C
 - 2 N/C
 - 3 N/C
 - 4 N/C
 - 5 N/C
 - 6 WHT(W6236) GROUND
 - 7 BLK(W6800) SW. BATTERY
 - 8 N/C
 - 9 N/C
 - 10 BLK(W2210) RIGHT FRONT PSW
 - 11 BLK(W7521) TAG DUMP SWITCH
 - 12 N/C

AP26074 CN11(GREEN)

- PIN
- 1 N/C
 - 2 N/C
 - 3 N/C
 - 4 N/C
 - 5 N/C
 - 6 WHT(W6235) GROUND
 - 7 N/C
 - 8 N/C
 - 9 N/C
 - 10 BLK(W1210) LEFT FRONT PSW
 - 11 N/C
 - 12 N/C

		HWH I-80 EXIT 267 SOUTH RT 1 MOSCOW, IOWA 52760	
		SCALE 1:3	DATE 08JAN03
		DRAWN BY .	
		SYSTEM SCHEMATIC ELEC	
NO.	DATE	REVISION	
THE INFORMATION DISCLOSED ON THIS DRAWING IS CONFIDENTIAL AND MUST NOT BE DISCLOSED OR USED IN ANY MANNER WHICH WILL BE DETRIMENTAL TO THE HWH CORPORATION		DRAWING NUMBER MP89012A/V	

AP29411
CENTRAL CONTROL/ROOM 1
MODULES

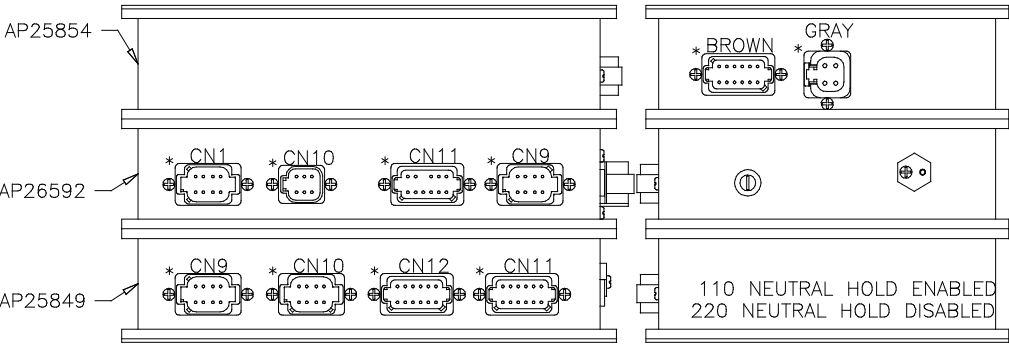

- AP25854 (BROWN)
PIN
- 1 BLK(W5050) CYLINDER EXTEND 1
 - 2 BLK(W5150) CYLINDER RETRACT 1
 - 3 N/C
 - 4 N/C
 - 5 BLK(W5051) CYLINDER EXTEND 2
 - 6 BLK(W5151) CYLINDER RETRACT 2
 - 7 BLK(W5600) AIR SEAL
 - 8 BLK(W5650) VACUUM
 - 9 BLK(W5301) UNLOCK ROOM 2
 - 10 BLK(W5201) LOCK ROOM 2
 - 11 WHT(W6230) GROUND
 - 12 N/C

- AP25854 (GRAY)
PIN
- 1 RED(W6800) SW BATT
 - 2 RED(W6800) SW BATT
 - 3 GRN(W6230) GROUND
 - 4 GRN(W6230) GROUND

- AP26592 CN1(BLACK)
PIN
- 1 WHT(W7696) SYSTEM WAKE UP
 - 2 N/C
 - 3 RED(W6800) SW BATT
 - 4 GRN(W6230) GND
 - 5 CAN SHIELD
 - 6 RED(W6110) IGNITION
 - 7 GRN CAN LOW
 - 8 YEL CAN HI

- AP26592 CN10(GRAY)
PIN
- 1 BLK(W7599) SWITCH LIGHT CONTROL
 - 2 RED(W6100) RESET OUT
 - 3 BLK(W7550) RESET IN
 - 4 RED(W6121) WARN LIGHT SUPPLY
 - 5 WHT(W6230) SWITCH LIGHT SUPPLY
 - 6 BLK(W7699) WARN LIGHT/BUZZER CONTROL

- AP26592 CN11(GRAY)
PIN
- 1 RED(W6110) IGNITION
 - 2 N/C
 - 3 N/C
 - 4 N/C
 - 5 RED(W6120) IGNITION
 - 6 RED(W6100) HOUSE BATTERY
 - 7 GRN(W6230) GROUND
 - 8 WHT(W9961) NEUTRAL HOLD
 - 9 WHT(W9955) NEUTRAL HOLD
 - 10 N/C
 - 11 WHT(W9000) PARK BRAKE SWITCH
 - 12 RED(W6101) HOUSE BATTERY

- AP26592 CN9(GREEN)
PIN
- 1 BLK(W8500) MASTER RELAY CNTRL
 - 2 BLK(W8100) SYSTEM PSW.
 - 3 N/C
 - 4 BLK(W8600) PMP RELAY CNTRL
 - 5 BLK(W9900) SPEED SWITCH
 - 6 BLK(W9901) SW BATT FROM PUMP RELAY
 - 7 N/C
 - 8 N/C

- AP25849 CN9(BLACK)
PIN
- 1 WHT(W7696) SYSTEM WAKE UP
 - 2 N/C
 - 3 RED(W6800) SW BATTERY
 - 4 GRN(W6230) GROUND
 - 5 CAN SHIELD
 - 6 RED(W6110) IGNITION
 - 7 GRN CAN LOW
 - 8 YEL CAN HI

- AP25849 CN10(GRAY)
PIN
- 1 N/C
 - 2 WHT(W7510) READY TO OPERATE
 - 3 WHT(W7530) PUMP
 - 4 WHT(W7501) EXTEND (ROOM 1)
 - 5 WHT(W7502) RETRACT (ROOM 1)
 - 6 RED(W6805) SW BATTERY
 - 7 WHT(W7696) SYSTEM WAKE UP
 - 8 GRN(W6230) GROUND

- AP25849 CN12(GRAY)
PIN
- 1 N/C
 - 2 BLK(W5701) FRONT ROOM OUT
 - 3 N/C
 - 4 N/C
 - 5 N/C
 - 6 WHT(W6230) GROUND
 - 7 RED(W6121) SW BATTERY
 - 8 N/C
 - 9 N/C
 - 10 BLK(W5703) UPPER FRONT ROOM IN
 - 11 BLK(W7695) SYNC PSW (NOT USED)
 - 12 N/C

- AP25849 CN 11 (GREEN)
PIN
- 1 N/C
 - 2 N/C
 - 3 N/C
 - 4 N/C
 - 5 N/C
 - 6 WHT(W6231) GROUND
 - 7 N/C
 - 8 BLK(W5651) VACUUM SENSE ROOM 1
 - 9 N/C
 - 10 N/C
 - 11 N/C
 - 12 N/C

AP26603
REAR AIR/ROOM 2
MODULE

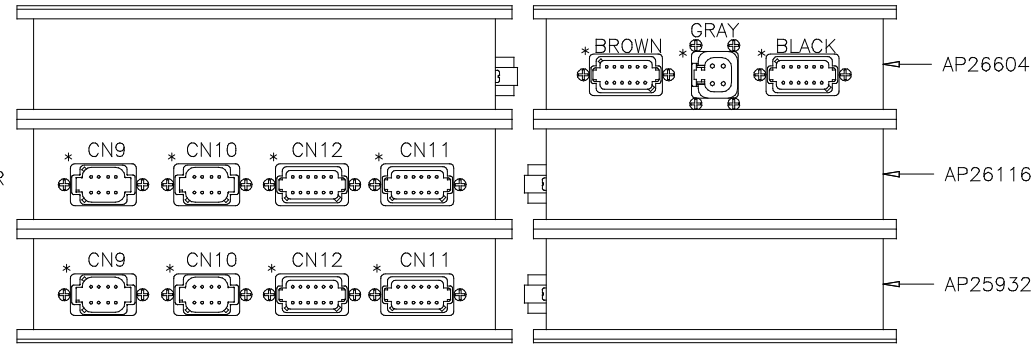

AP26604 (BROWN)

PIN	DESCRIPTION
1	BLK(W5650) VACUUM
2	BLK(W5600) AIR SEAL
3	N/C
4	N/C
5	N/C
6	N/C
7	N/C
8	N/C
9	N/C
10	N/C
11	WHT(W6230) GROUND
12	N/C

AP26604 (GRAY)

PIN	DESCRIPTION
1	RED (W6800) SW BATT
2	RED (W6800) SW BATT
3	GRN (W6230) GND
4	GRN (W6230) GND

AP26604 (BLACK)

PIN	DESCRIPTION
1	BLK(W3800) TAG LIFT
2	BLK(W4500) LEFT REAR RAISE
3	BLK(W4600) LEFT REAR LOWER
4	BLK(W3500) RIGHT REAR RAISE
5	BLK(W3600) RIGHT REAR LOWER
6	N/C
7	BLK(W3701) TAG TRAVEL
8	BLK(W3700) TRAVEL
9	BLK(W3601) TAG RIGHT LOWER
10	BLK(W4601) TAG LEFT LOWER
11	WHT(W6258) GROUND
12	N/C

AP26116 CN9(BLACK)

PIN	DESCRIPTION
1	N/C
2	N/C
3	N/C
4	N/C
5	N/C
6	N/C
7	N/C
8	N/C

AP26116 CN10(GRAY)

PIN	DESCRIPTION
1	N/C
2	N/C
3	N/C
4	N/C
5	N/C
6	N/C
7	N/C
8	N/C

AP26116 CN12(GRAY)

PIN	DESCRIPTION
1	BLK(W4211) LEFT REAR TAG PRESS SW.
2	BLK(W3211) RIGHT REAR TAG PRESS SW.
3	BLK (W3215) SYSTEM PRESS SW.
4	N/C
5	N/C
6	WHT (W6231) GROUND
7	N/C
8	N/C
9	N/C
10	N/C
11	N/C
12	N/C

AP26116 CN11(GREEN)

PIN	DESCRIPTION
1	N/C
2	BLK(W4210) LEFT REAR PRESS SW.
3	BLK(W3210) RIGHT REAR PRESS SW.
4	N/C
5	N/C
6	WHT(W6232) GROUND
7	N/C
8	N/C
9	N/C
10	N/C
11	N/C
12	N/C

AP25932 CN9(BLACK)

PIN	DESCRIPTION
1	WHT(W7696) SYSTEM WAKE UP
2	N/C
3	RED(W6800) SW BATTERY
4	GRN(W6230) GROUND
5	CAN SHIELD
6	RED(W6110) IGNITION
7	GRN CAN LOW
8	YEL CAN HI

AP25932 CN10(GRAY)

PIN	DESCRIPTION
1	N/C
2	WHT(W7510) READY TO OPERATE
3	WHT(W7530) PUMP
4	WHT(W7501) EXTEND (ROOM 2)
5	WHT(W7502) RETRACT (ROOM 2)
6	RED(W6805) SW BATTERY
7	WHT(W7696) SYSTEM WAKE UP
8	GRN(W6230) GROUND

AP25932 CN12(GRAY)

PIN	DESCRIPTION
1	BLK(W5706) LOWER FRONT UNLOCK
2	BLK(W5701) FRONT ROOM OUT
3	N/C
4	BLK(W5710) LOWER FRONT LOCK
5	N/C
6	WHT(W6230) GROUND
7	RED(W6121) SW BATTERY
8	N/C
9	BLK(W5708) UPPER FRONT LOCK
10	BLK(W5703) UPPER FRONT ROOM IN
11	N/C
12	BLK(W5704) UPPER FRONT UNLOCK

AP25932 CN 11(GREEN)

PIN	DESCRIPTION
1	N/C
2	N/C
3	N/C
4	N/C
5	N/C
6	WHT(W6231) GROUND
7	N/C
8	BLK(W5651) VACUUM SENSE ROOM 2
9	N/C
10	N/C
11	N/C
12	N/C

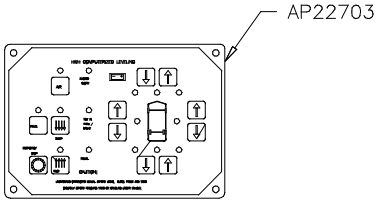

5 1

- PIN
- 1 YELLOW CAN HI
 - 2 GREEN CAN LOW
 - 3 CAN SHIELD
 - 4 GRN (W6230) GROUND
 - 5 RED (W6800) SW. BATTERY

120 OHM
TERMINATION
RESISTOR
PART OF OEM
PROVIDED TRUNK
HARNESS #72308.

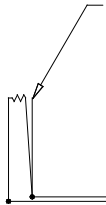

OEM #72308

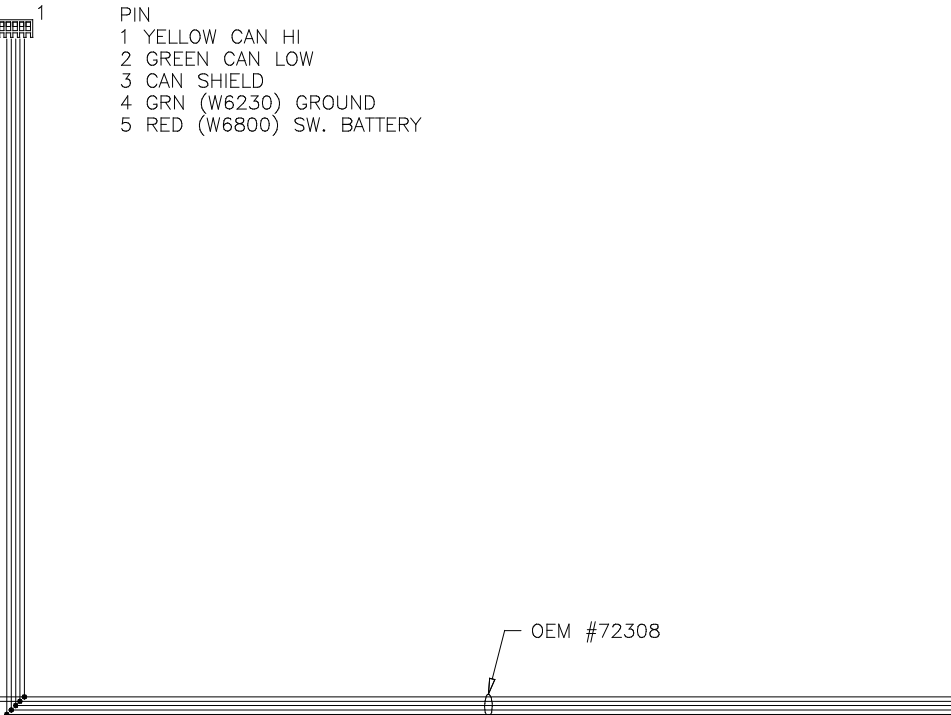

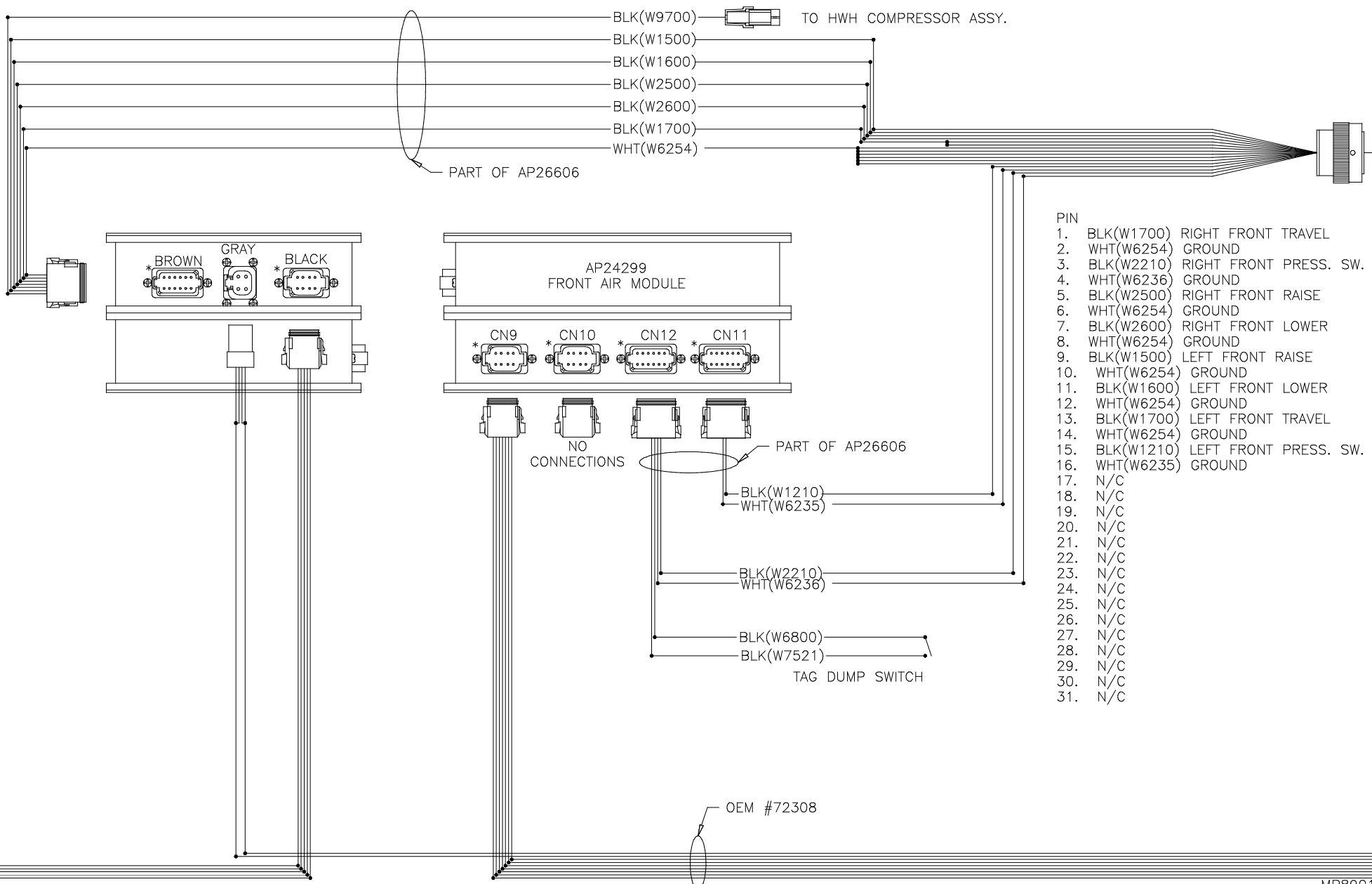

- PIN
1. BLK(W1700) RIGHT FRONT TRAVEL
 2. WHT(W6254) GROUND
 3. BLK(W2210) RIGHT FRONT PRESS. SW.
 4. WHT(W6236) GROUND
 5. BLK(W2500) RIGHT FRONT RAISE
 6. WHT(W6254) GROUND
 7. BLK(W2600) RIGHT FRONT LOWER
 8. WHT(W6254) GROUND
 9. BLK(W1500) LEFT FRONT RAISE
 10. WHT(W6254) GROUND
 11. BLK(W1600) LEFT FRONT LOWER
 12. WHT(W6254) GROUND
 13. BLK(W1700) LEFT FRONT TRAVEL
 14. WHT(W6254) GROUND
 15. BLK(W1210) LEFT FRONT PRESS. SW.
 16. WHT(W6235) GROUND
 17. N/C
 18. N/C
 19. N/C
 20. N/C
 21. N/C
 22. N/C
 23. N/C
 24. N/C
 25. N/C
 26. N/C
 27. N/C
 28. N/C
 29. N/C
 30. N/C
 31. N/C

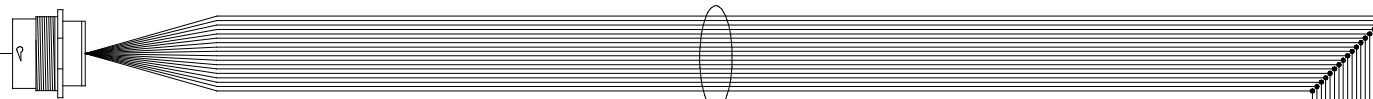

- PIN
1. RIGHT FRONT TRAVEL
 2. GROUND
 3. RIGHT FRONT PRESS. SW.
 4. GROUND
 5. RIGHT FRONT RAISE
 6. GROUND
 7. RIGHT FRONT LOWER
 8. GROUND
 9. LEFT FRONT RAISE
 10. GROUND
 11. LEFT FRONT LOWER
 12. GROUND
 13. LEFT FRONT TRAVEL
 14. GROUND
 15. LEFT FRONT PRESS. SW.
 16. GROUND
 17. SYSTEM PRESS. SW.
 18. GROUND
 19. N/C
 20. N/C
 21. N/C
 22. N/C
 23. N/C
 24. N/C
 25. N/C
 26. N/C
 27. N/C
 28. N/C
 29. N/C
 30. N/C
 31. N/C

AP25285

FRONT AIR
MANIFOLD
CONNECTIONS

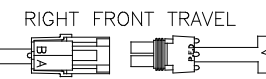
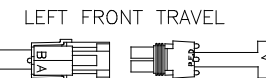
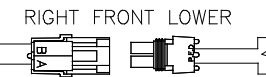
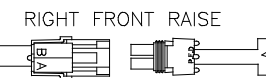
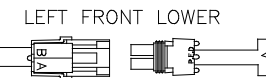
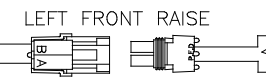

SYSTEM PRESSURE SWITCH
(NOT USED)

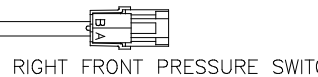

OEM #72308



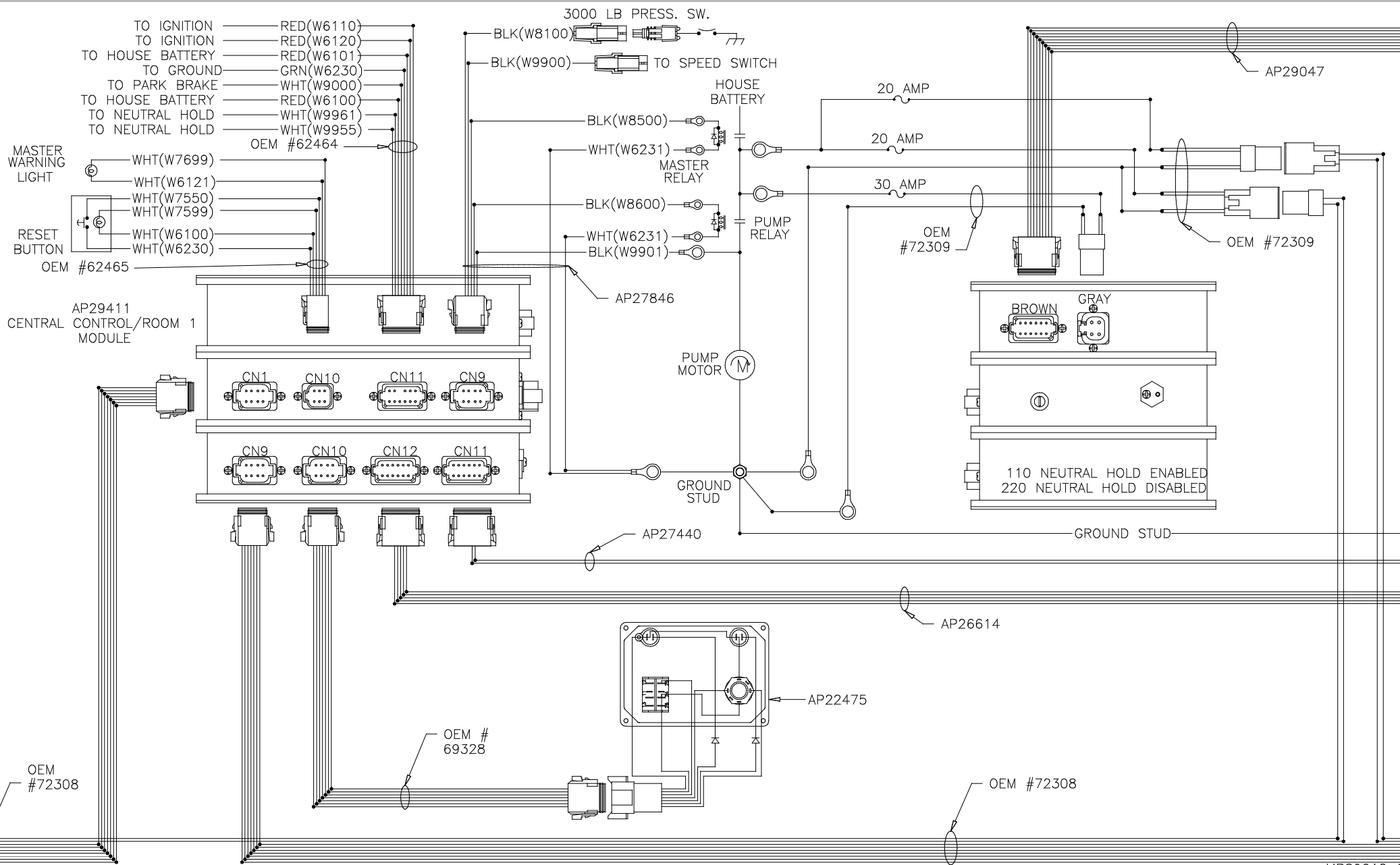

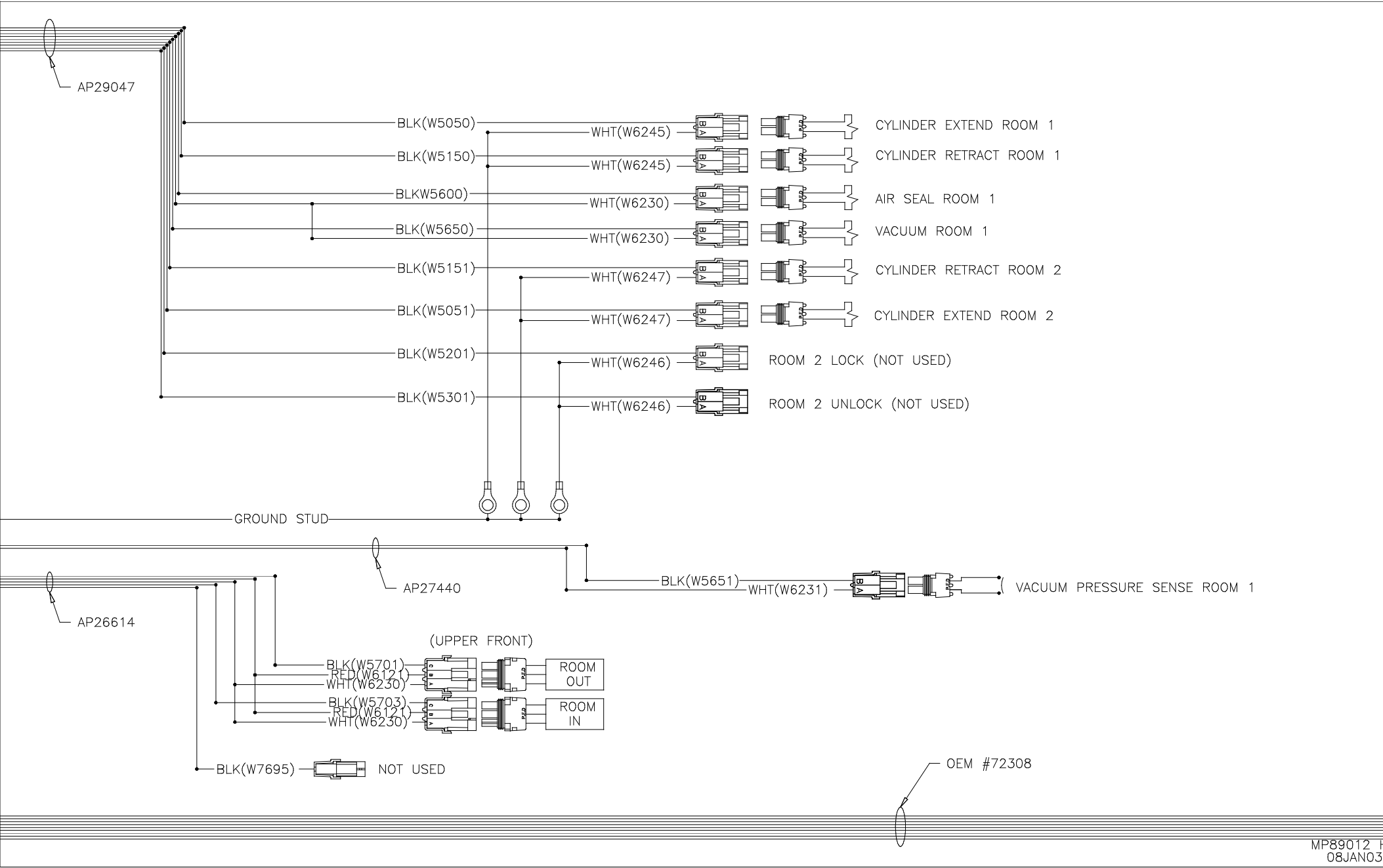

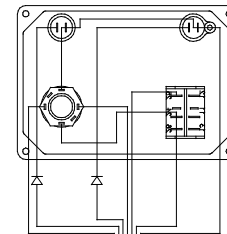

AP22475

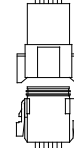

OEM #69328

OEM #72308

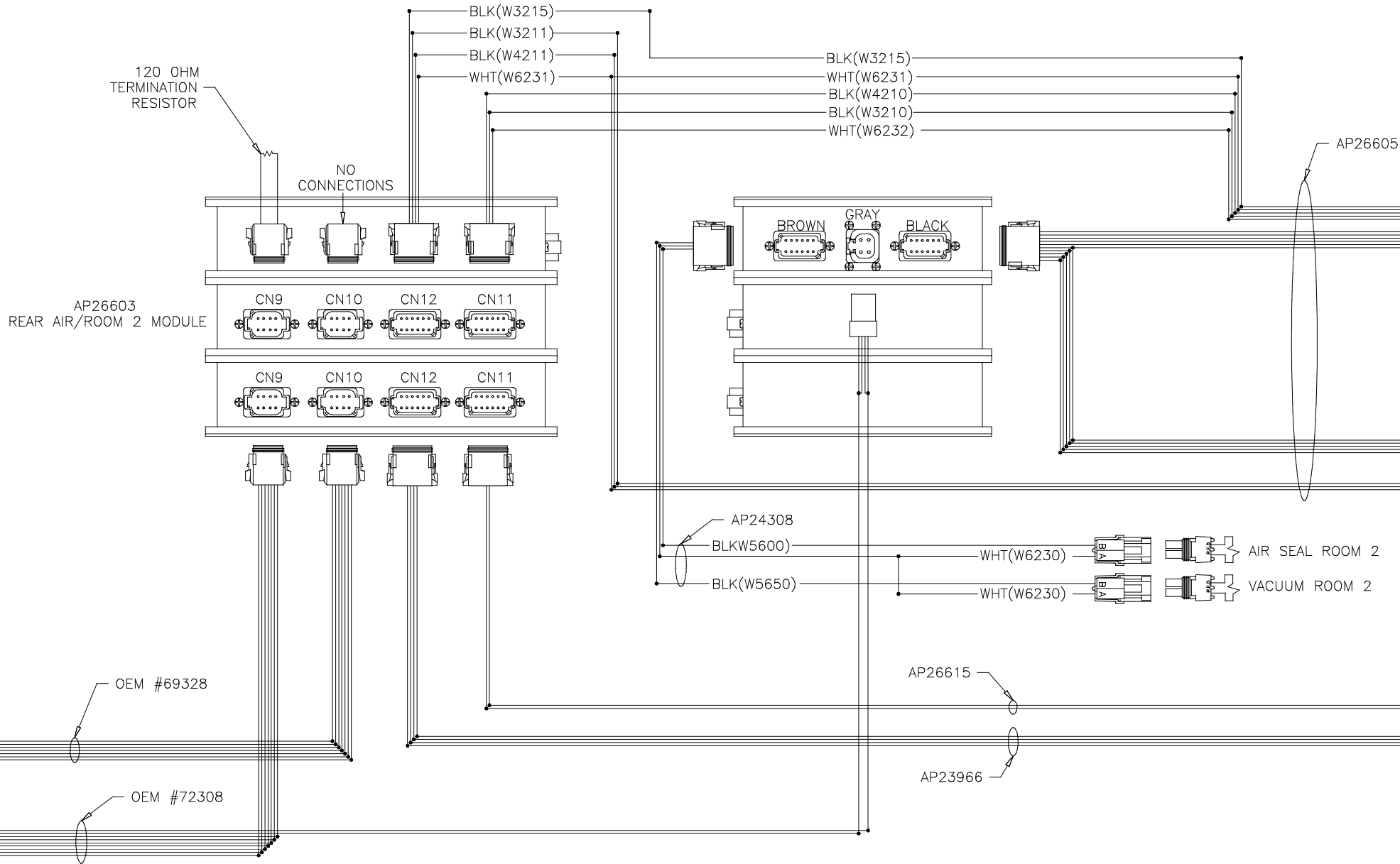

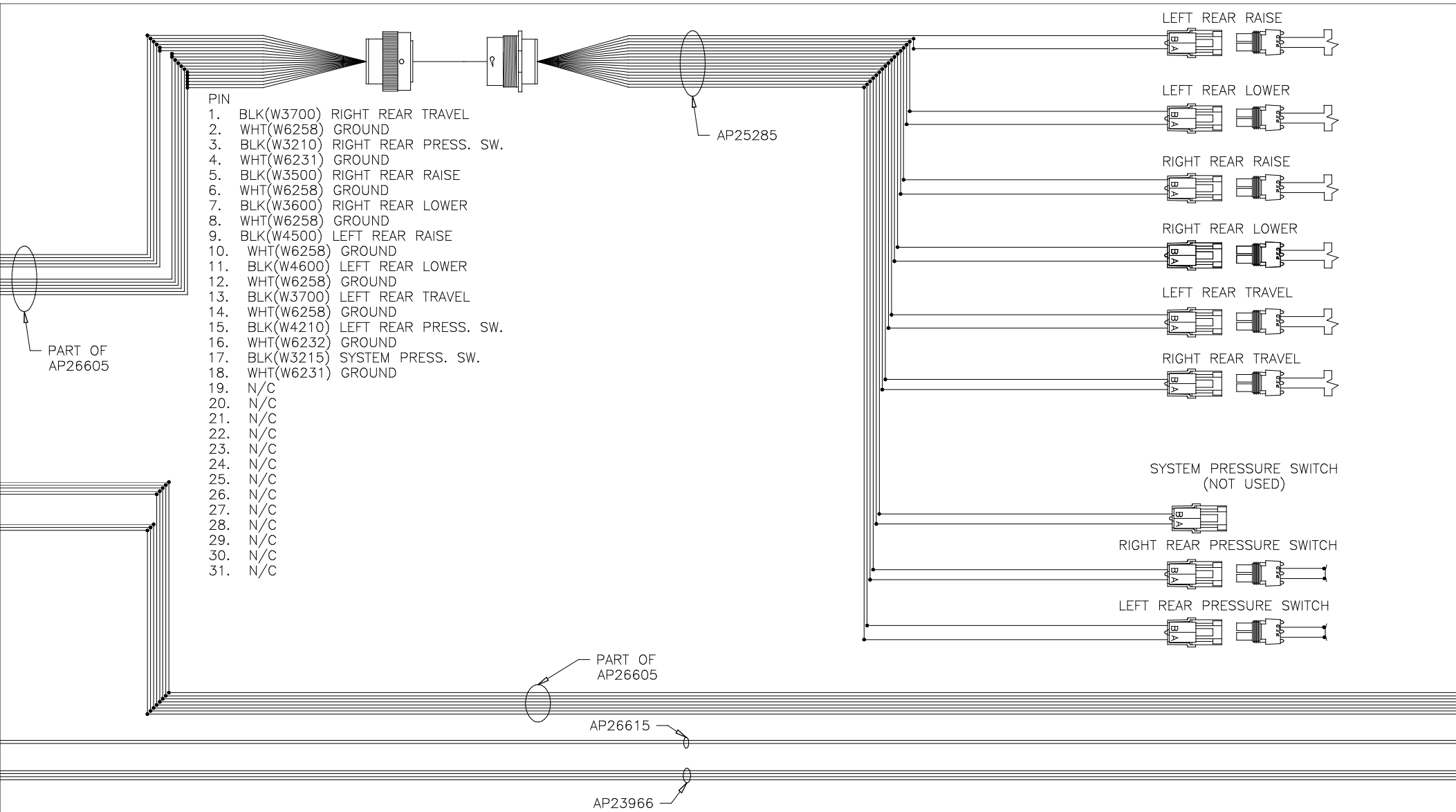

- PIN
1. BLK(W3701) TAG RIGHT SIDE TRAVEL
 2. WHT(W6258) GROUND
 3. BLK(W3211) TAG RIGHT SIDE PRESS. SW.
 4. WHT(W6231) GROUND
 5. BLK(W3800) TAG LIFT
 6. WHT(W6258) GROUND
 7. BLK(W3601) TAG RIGHT SIDE DUMP
 8. WHT(W6258) GROUND
 9. BLK(W3701) TAG LIFT EXHAUST
 10. WHT(W6258) GROUND
 11. BLK(W4601) TAG LEFT SIDE DUMP
 12. WHT(W6258) GROUND
 13. BLK(W3701) TAG LEFT SIDE TRAVEL
 14. WHT(W6258) GROUND
 15. BLK(W4211) TAG LEFT SIDE PRESS. SW.
 16. WHT(W6231) GROUND
 17. N/C
 18. N/C
 19. N/C
 20. N/C
 21. N/C
 22. N/C
 23. N/C
 24. N/C
 25. N/C
 26. N/C
 27. N/C
 28. N/C
 29. N/C
 30. N/C
 31. N/C

TAG AXLE
AIR MANIFOLD
CONNECTIONS

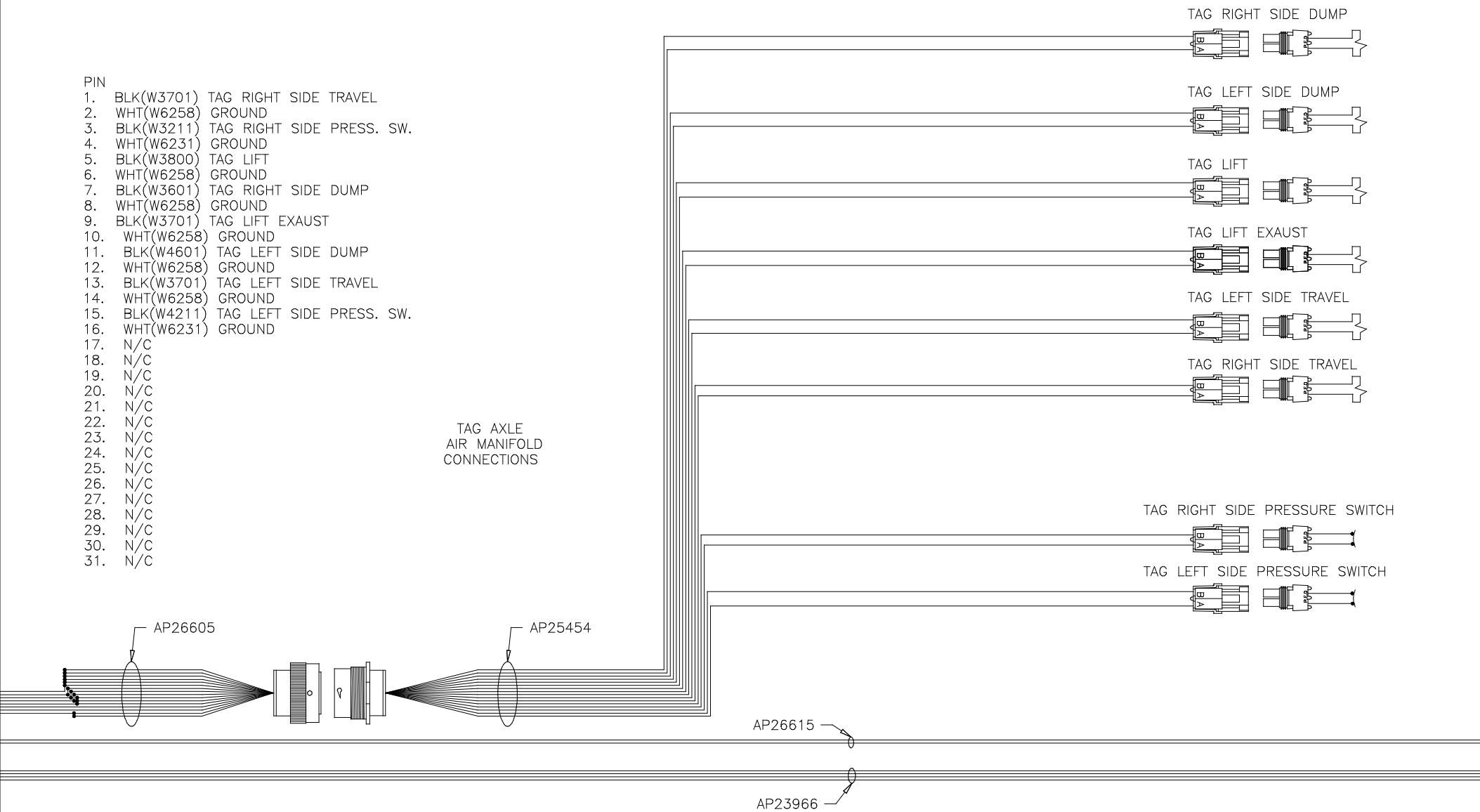

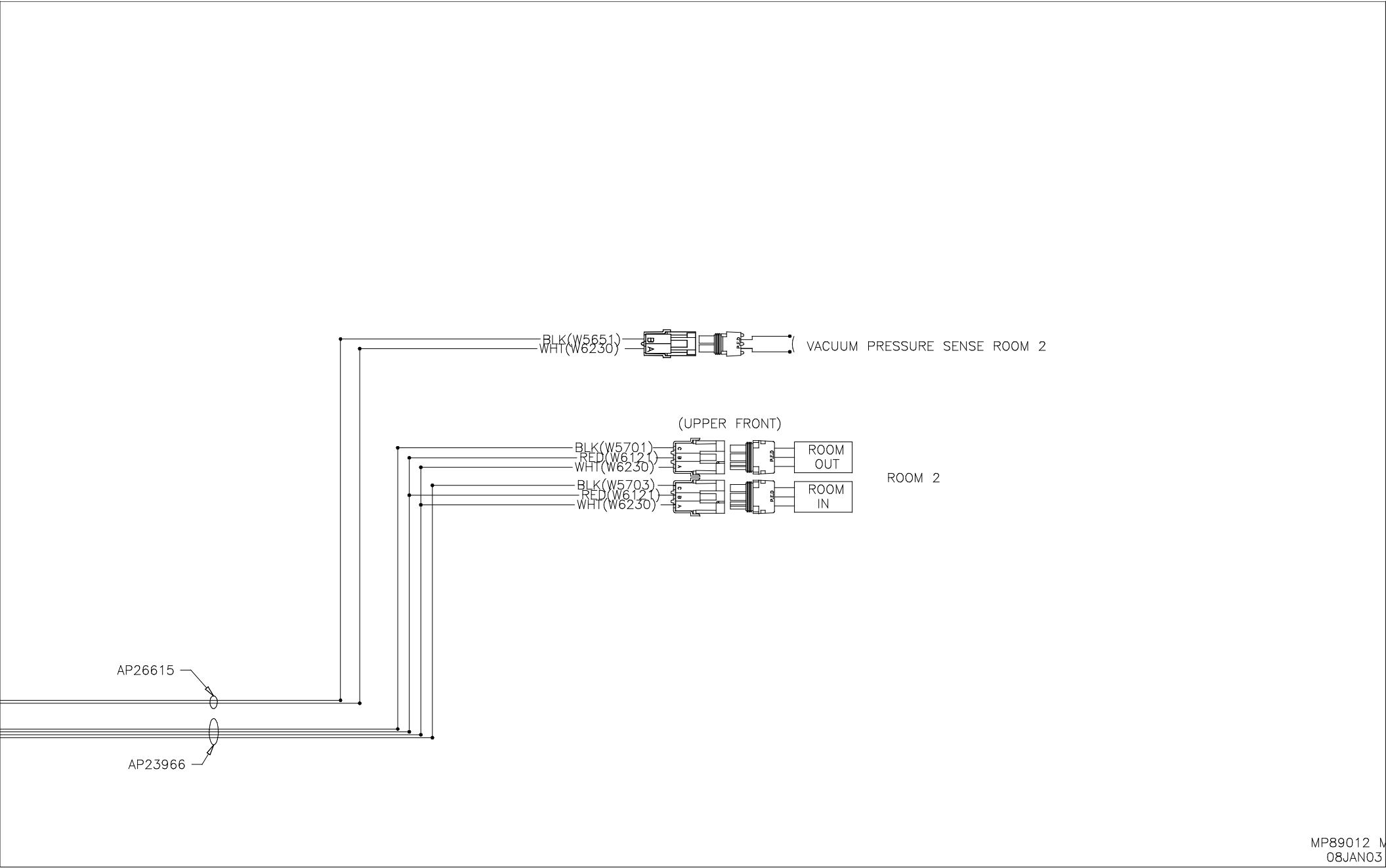

FRONT AIR
MODULE
LED LAYOUT

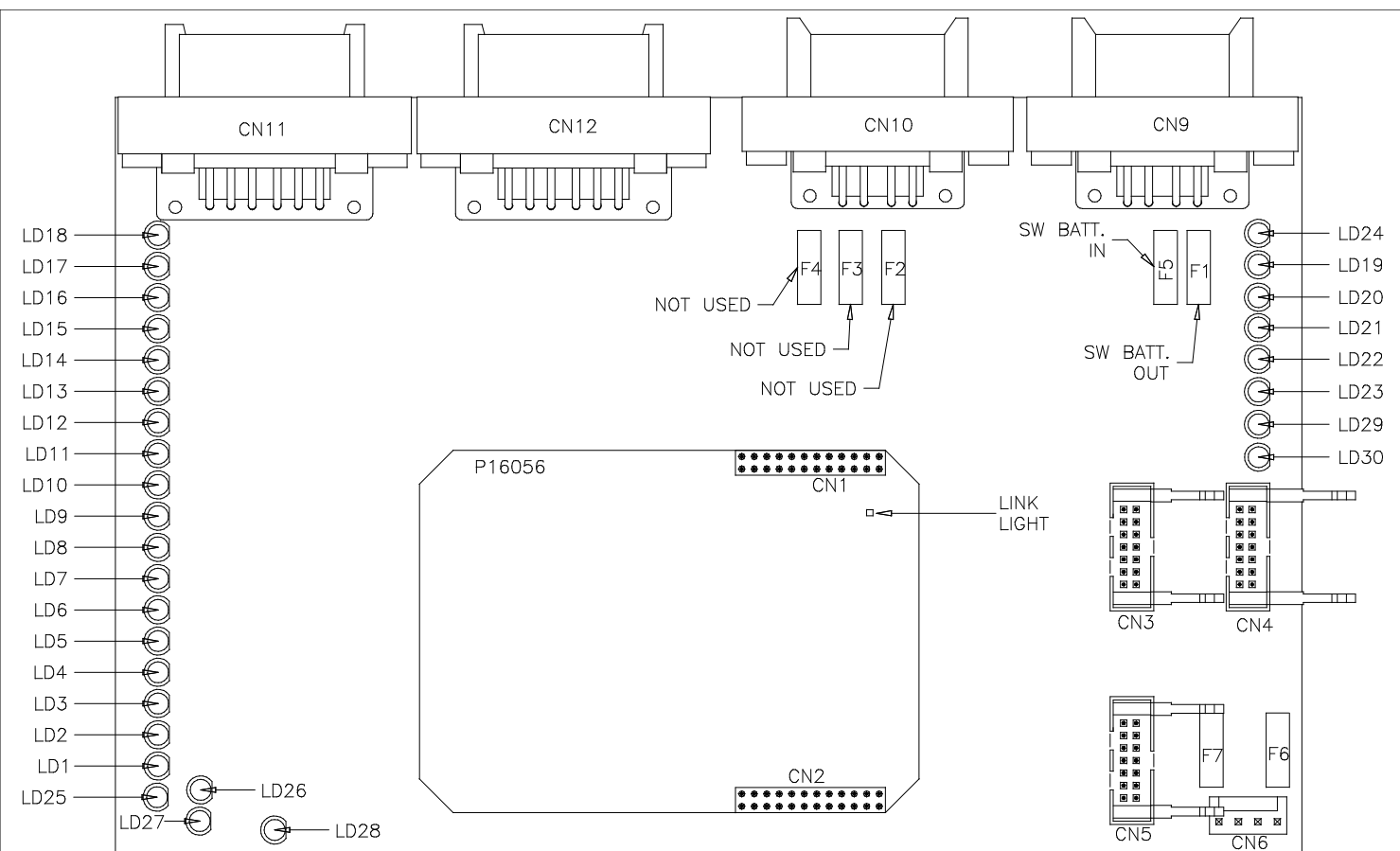

LED #	CONNECTOR	COLOR	DESCRIPTION	LED #	CONNECTOR	COLOR	DESCRIPTION
LED 1	NOT USED	RED	NOT USED	LED 16	NOT USED	GREEN	NOT USED
LED 2	NOT USED	RED	NOT USED	LED 17	NOT USED	GREEN	NOT USED
LED 3	NOT USED	GREEN	NOT USED	LED 18	NOT USED	GREEN	NOT USED
LED 4	NOT USED	YELLOW	NOT USED	LED 19	CN11/CN12 PIN 7	RED	12V OUTPUT
LED 5	NOT USED	YELLOW	NOT USED	LED 20	NOT USED	RED	NOT USED
LED 6	NOT USED	YELLOW	NOT USED	LED 21	NOT USED	RED	NOT USED
LED 7	NOT USED	GREEN	NOT USED	LED 22	NOT USED	RED	NOT USED
LED 8	NOT USED	GREEN	NOT USED	LED 23	NOT USED	RED	NOT USED
LED 9	CN11 PIN 10	GREEN	LEFT FRONT PSW	LED 24	NOT USED	RED	NOT USED
LED 10	CN12 PIN 10	GREEN	RIGHT FRONT PSW	LED 25	---	RED	---
LED 11	NOT USED	YELLOW	NOT USED	LED 26	---	RED	---
LED 12	NOT USED	YELLOW	NOT USED	LED 27	---	RED	---
LED 13	NOT USED	YELLOW	NOT USED	LED 28	CN 12 PIN 11	RED	TAG DUMP
LED 14	NOT USED	YELLOW	NOT USED	LED 29	---	RED	---
LED 15	NOT USED	GREEN	NOT USED	LED 30	---	RED	---

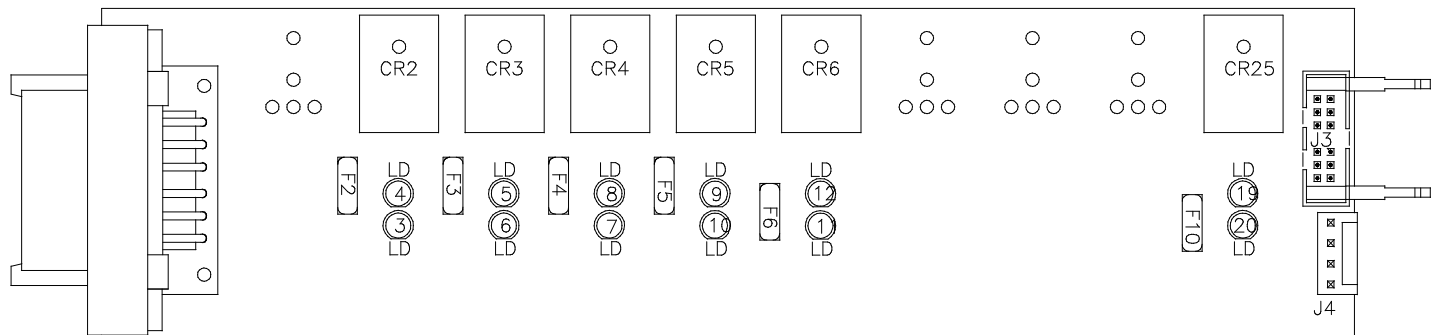

FRONT AIR
LED LAYOUT

LED #	COLOR	INPUT J3	FUSE #	OUTPUT	RELAY #	DESCRIPTION
LED1	---	---	---	---	---	---
LED2	---	---	---	---	---	---
LED3	RED	---	FUSE 2	PIN 2	CR2	LEFT FRONT RAISE (CONTACT)
LED4	YELLOW	PIN 12	---	---	CR2	LEFT FRONT RAISE (COIL)
LED5	YELLOW	PIN 11	---	---	CR3	LEFT FRONT LOWER (COIL)
LED6	RED	---	FUSE 3	PIN 3	CR3	LEFT FRONT LOWER (CONTACT)
LED7	RED	---	FUSE 4	PIN 4	CR4	RIGHT FRONT RAISE (CONTACT)
LED8	YELLOW	PIN 10	---	---	CR4	RIGHT FRONT RAISE (COIL)
LED9	YELLOW	PIN 9	---	---	CR5	RIGHT FRONT LOWER (COIL)
LED10	RED	---	FUSE 5	PIN 5	CR5	RIGHT FRONT LOWER (CONTACT)
LED11	RED	---	FUSE 6	PIN 6	CR6	COMPRESSOR (CONTACT)
LED12	YELLOW	PIN 8	---	---	CR6	COMPRESSOR (COIL)
LED13	---	---	---	---	---	---
LED14	---	---	---	---	---	---
LED15	---	---	---	---	---	---
LED16	---	---	---	---	---	---
LED17	---	---	---	---	---	---
LED18	---	---	---	---	---	---
LED19	YELLOW	PIN 4	---	---	CR25	TRAVEL (COIL)
LED20	RED	---	FUSE 10	PIN 8	CR25	TRAVEL (CONTACT)

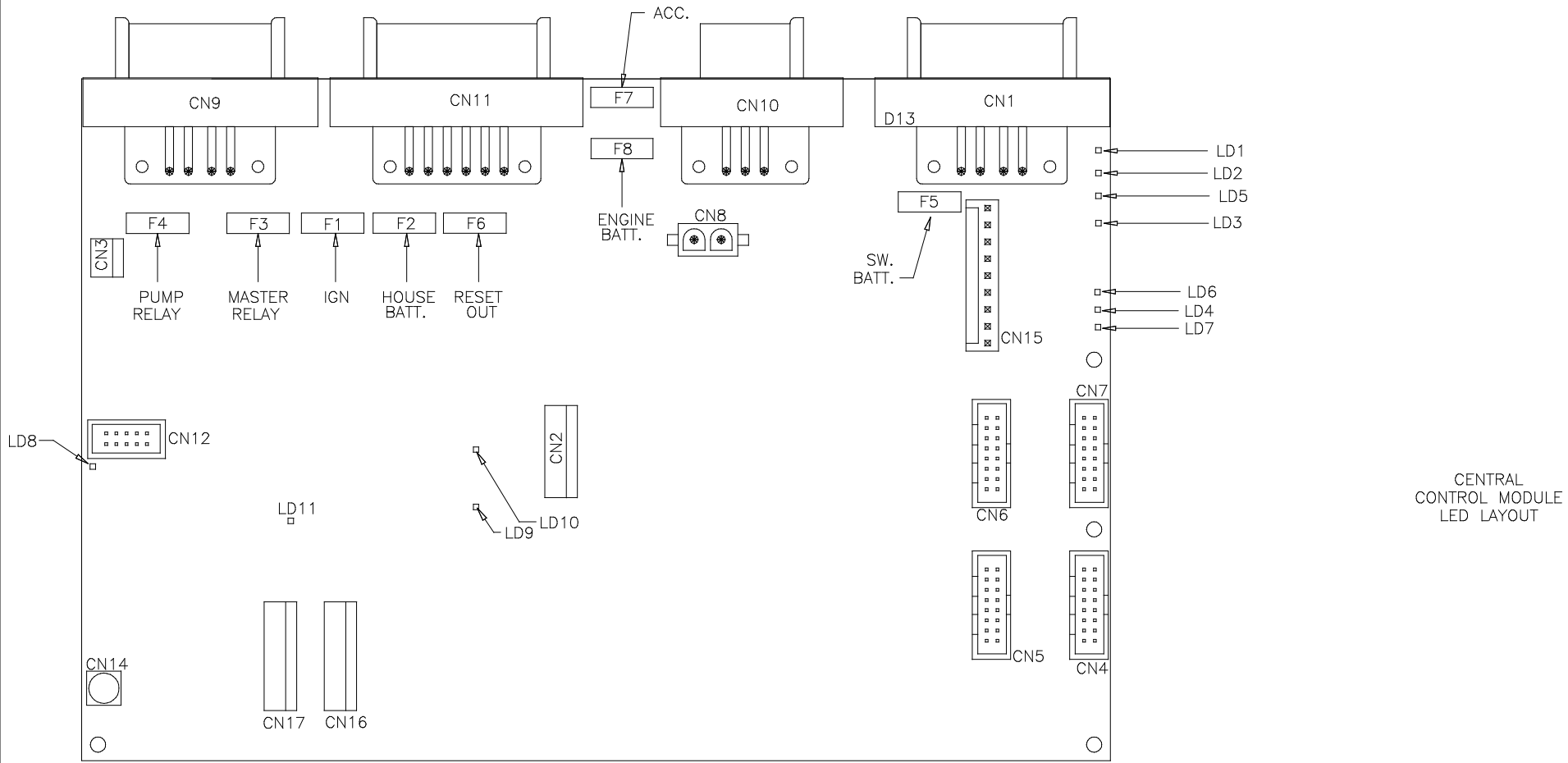

LED #	CONNECTOR	COLOR	DESCRIPTION
LED 1	CN 9 PIN 1	RED	MASTER RELAY
LED 2	CN 9 PIN 4	RED	PUMP RELAY
LED 3	CN 1 PIN 3	RED	SW 12V
LED 4	CN 11 PIN 12	RED	ENGINE BATT
LED 5	CN 9 PIN 5	RED	SPEED SWITCH
LED 6	NOT USED	NOT USED	NOT USED

LED #	CONNECTOR	COLOR	DESCRIPTION
LED 7	CN 1 PIN 7 & 8	RED	LINK LIGHT
LED 8	CN 11 PIN 8 & 9	RED	NEUTRAL HOLD
LED 9	NOT USED	NOT USED	NOT USED
LED 10	CN9 PIN 2	RED	3000 LBS. PSW
LED 11	CN11 PIN 11	RED	PARK BRAKE

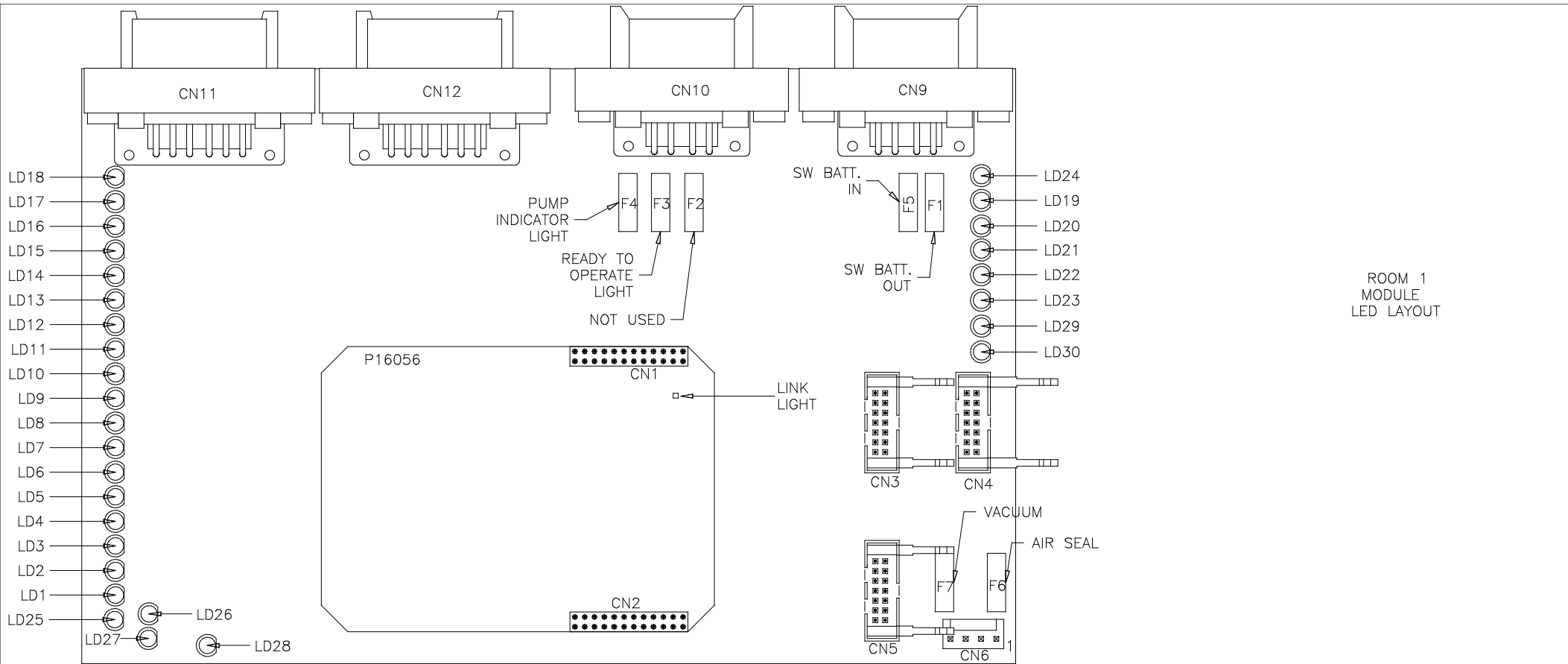

LED #	CONNECTOR	COLOR	DESCRIPTION
LED 1	CN10 PIN 4	RED	EXTEND
LED 2	CN10 PIN 5	RED	RETRACT
LED 3	NOT USED	GREEN	NOT USED
LED 4	NOT USED	YELLOW	NOT USED
LED 5	NOT USED	YELLOW	NOT USED
LED 6	CN12 PIN 2	YELLOW	FRONT ROOM OUT
LED 7	NOT USED	GREEN	NOT USED
LED 8	NOT USED	GREEN	NOT USED
LED 9	NOT USED	GREEN	NOT USED
LED 10	CN12 PIN 10	GREEN	UPPER FRONT ROOM IN
LED 11	NOT USED	YELLOW	NOT USED
LED 12	NOT USED	YELLOW	NOT USED
LED 13	NOT USED	YELLOW	NOT USED
LED 14	NOT USED	YELLOW	NOT USED
LED 15	NOT USED	GREEN	NOT USED

LED #	CONNECTOR	COLOR	DESCRIPTION
LED 16	NOT USED	GREEN	NOT USED
LED 17	NOT USED	GREEN	NOT USED
LED 18	NOT USED	GREEN	NOT USED
LED 19	CN11/CN12 PIN 7	RED	12V OUTPUT
LED 20	CN9 PIN 3	RED	SW BATT
LED 21	CN10 PIN 3	RED	PUMP INDICATOR
LED 22	CN10 PIN 2	RED	READY TO OPERATE
LED 23	NOT USED	RED	NOT USED
LED 24	CN10 PIN 7	RED	SYSTEM WAKE UP
LED 25	---	RED	---
LED 26	---	RED	---
LED 27	CN11 PIN 8	RED	VACUUM SENSE
LED 28	NOT USED	RED	NOT USED
LED 29	CN6 PIN 1	RED	AIR SEAL OUTPUT
LED 30	NOT USED	RED	NOT USED

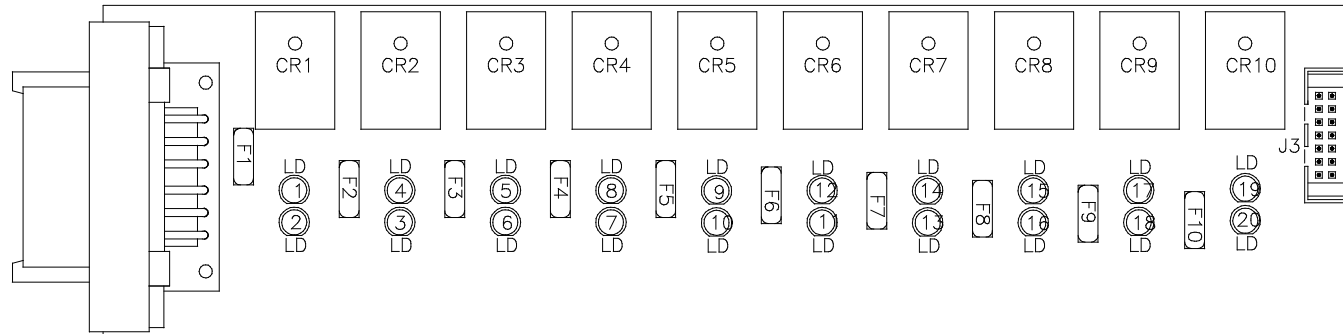

ROOM 1
LED LAYOUT

LED #	COLOR	INPUT J3	FUSE #	OUTPUT	RELAY #	DESCRIPTION
LED1	YELLOW	PIN 13	---	---	CR1	CYL EXTEND 1 (COIL)
LED2	RED	---	FUSE 1	PIN 1	CR1	CYL EXTEND 1 (CONTACT)
LED3	RED	---	FUSE 2	PIN 2	CR2	CYL RETRACT1 (CONTACT)
LED4	YELLOW	PIN 12	---	---	CR2	CYL RETRACT RM 1 (COIL)
LED5	YELLOW	PIN 11	---	---	CR3	NOT USED
LED6	RED	---	FUSE 3	PIN 3	CR3	NOT USED
LED7	RED	---	FUSE 4	PIN 4	CR4	NOT USED
LED8	YELLOW	PIN 10	---	---	CR4	NOT USED
LED9	YELLOW	PIN 9	---	---	CR5	CYL EXTEND 2 (COIL)
LED10	RED	---	FUSE 5	PIN 5	CR5	CYL EXTEND 2 (CONTACT)
LED11	RED	---	FUSE 6	PIN 6	CR6	CYL RETRACT 2 (CONTACT)
LED12	YELLOW	PIN 8	---	---	CR6	CYL RETRACT 2 (COIL)
LED13	RED	---	FUSE 7	PIN 10	CR7	LOCK RM 2 (COIL)
LED14	YELLOW	PIN 7	---	---	CR7	LOCK RM 2 (CONTACT)
LED15	YELLOW	PIN 6	---	---	CR8	UNLOCK RM 2 (CONTACT)
LED16	RED	---	FUSE8	PIN 9	CR8	UNLOCK RM 2 (COIL)
LED17	YELLOW	PIN 5	---	---	CR9	AIR SEAL (COIL)
LED18	RED	---	FUSE 9	PIN 7	CR9	AIR SEAL (CONTACT)
LED19	YELLOW	PIN 4	---	---	CR10	VACUUM (COIL)
LED20	RED	---	FUSE 10	PIN 8	CR10	VACUUM (CONTACT)

REAR AIR
MODULE
LED LAYOUT

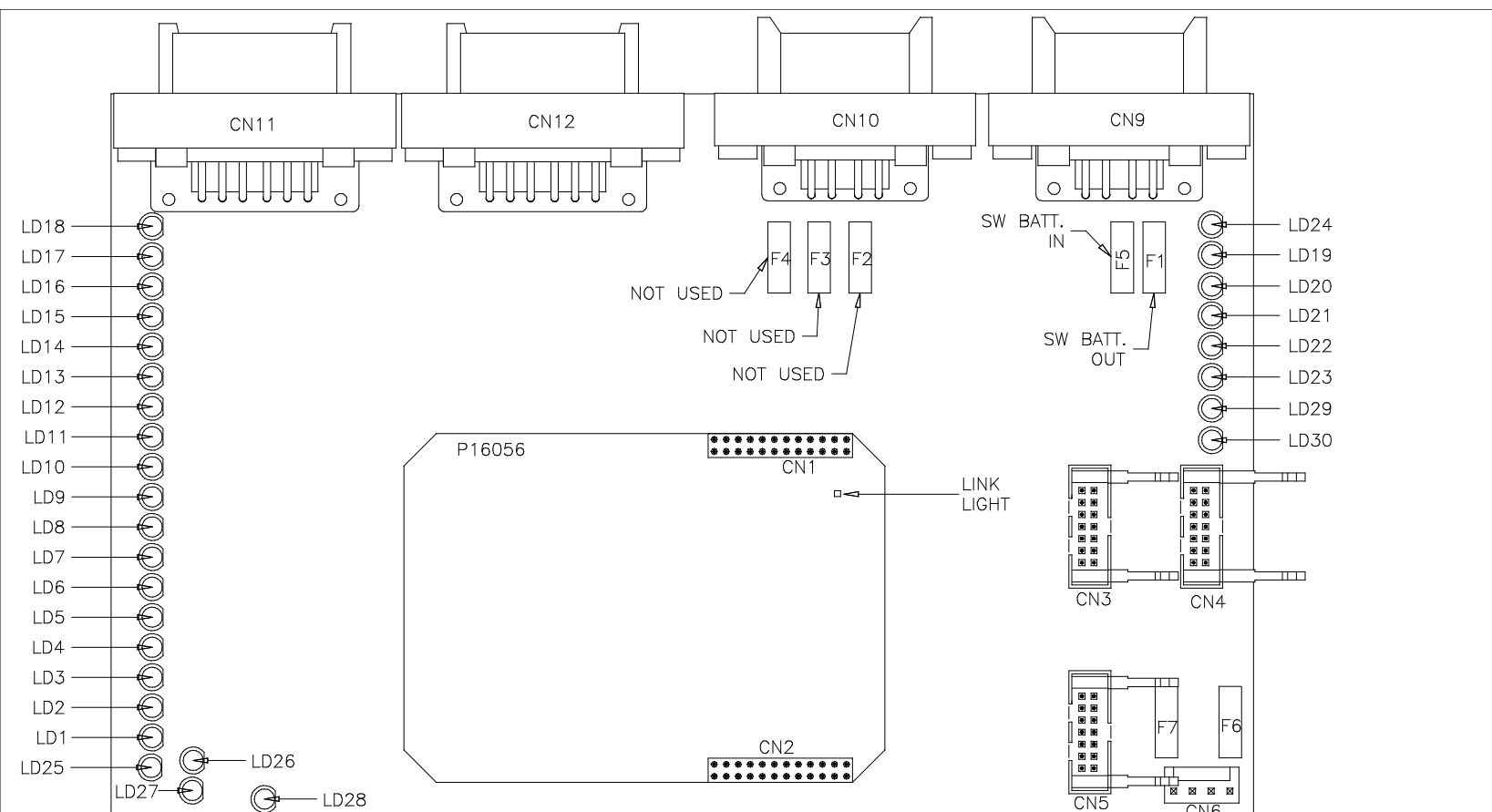

LED #	CONNECTOR	COLOR	DESCRIPTION	LED #	CONNECTOR	COLOR	DESCRIPTION
LED 1	NOT USED	RED	NOT USED	LED 16	NOT USED	GREEN	NOT USED
LED 2	NOT USED	RED	NOT USED	LED 17	NOT USED	GREEN	NOT USED
LED 3	NOT USED	GREEN	NOT USED	LED 18	NOT USED	GREEN	NOT USED
LED 4	NOT USED	YELLOW	NOT USED	LED 19	CN11/CN12 PIN 7	RED	12V OUT
LED 5	CN11 PIN 2	YELLOW	LEFT REAR PRESS. SW.	LED 20	NOT USED	RED	NOT USED
LED 6	CN12 PIN 2	YELLOW	RIGHT REAR TAG PRESS. SW.	LED 21	NOT USED	RED	NOT USED
LED 7	CN11 PIN 3	GREEN	RIGHT REAR PRESS. SW.	LED 22	NOT USED	RED	NOT USED
LED 8	CN12 PIN 3	GREEN	SYSTEM PRESS SW.	LED 23	NOT USED	RED	NOT USED
LED 9	NOT USED	GREEN	NOT USED	LED 24	NOT USED	RED	NOT USED
LED 10	NOT USED	GREEN	NOT USED	LED 25	---	RED	---
LED 11	NOT USED	YELLOW	NOT USED	LED 26	---	RED	---
LED 12	CN12 PIN 1	YELLOW	LEFT REAR TAG PRESS. SW.	LED 27	---	RED	---
LED 13	NOT USED	YELLOW	NOT USED	LED 28	---	RED	---
LED 14	NOT USED	YELLOW	NOT USED	LED 29	---	RED	---
LED 15	NOT USED	GREEN	NOT USED	LED 30	---	RED	---

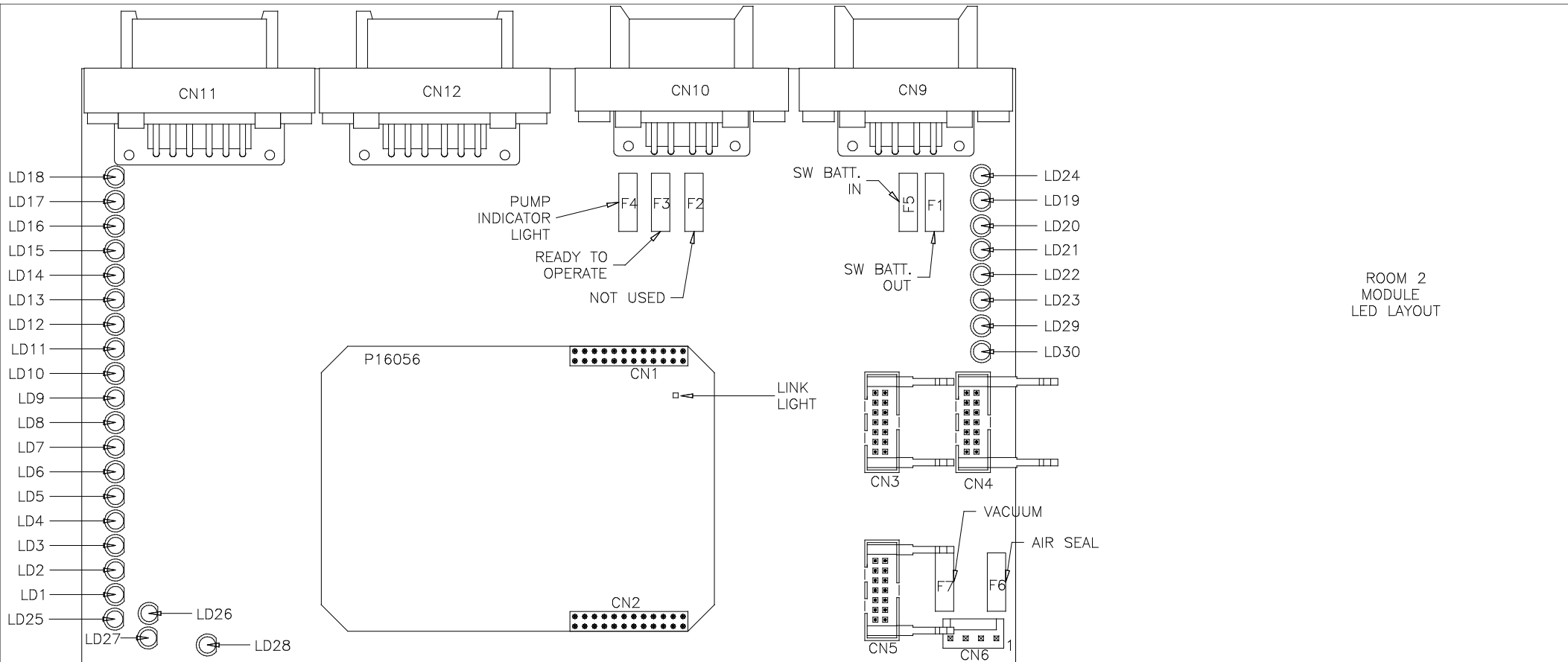

ROOM 2
MODULE
LED LAYOUT

LED #	CONNECTOR	COLOR	DESCRIPTION	LED #	CONNECTOR	COLOR	DESCRIPTION
LED 1	CN10 PIN 4	RED	EXTEND	LED 16	CN12 PIN 4	GREEN	LOWER FRONT LOCK
LED 2	CN10 PIN 5	RED	RETRACT	LED 17	CN11 PIN 9	GREEN	UPPER REAR LOCK
LED 3	NOT USED	GREEN	NOT USED	LED 18	CN12 PIN 9	GREEN	UPPER FRONT LOCK
LED 4	NOT USED	YELLOW	NOT USED	LED 19	CN11/CN12 PIN 7	RED	12V OUTPUT
LED 5	NOT USED	YELLOW	NOT USED	LED 20	CN9 PIN 3	RED	SW BATT
LED 6	CN12 PIN 2	YELLOW	FRONT ROOM OUT	LED 21	CN10 PIN 3	RED	PUMP INDICATOR
LED 7	NOT USED	GREEN	NOT USED	LED 22	CN10 PIN 2	RED	READY TO OPERATE
LED 8	NOT USED	GREEN	NOT USED	LED 23	NOT USED	RED	NOT USED
LED 9	CN11 PIN 10	GREEN	UPPER REAR ROOM IN	LED 24	CN10 PIN 7	RED	SYSTEM WAKE UP
LED 10	CN12 PIN 10	GREEN	UPPER FRONT ROOM IN	LED 25	---	RED	---
LED 11	CN11 PIN 1	YELLOW	LOWER REAR UNLOCK	LED 26	---	RED	---
LED 12	CN12 PIN 1	YELLOW	LOWER FRONT UNLOCK	LED 27	CN11 PIN 8	RED	VACUUM SENSE
LED 13	CN11 PIN 12	YELLOW	UPPER REAR UNLOCK	LED 28	NOT USED	RED	NOT USED
LED 14	CN12 PIN 12	YELLOW	UPPER FRONT UNLOCK	LED 29	CN6 PIN 1	RED	AIR SEAL OUTPUT
LED 15	CN11 PIN 4	GREEN	LOWER REAR LOCK	LED 30	CN6 PIN 3	RED	VACUUM OUTPUT

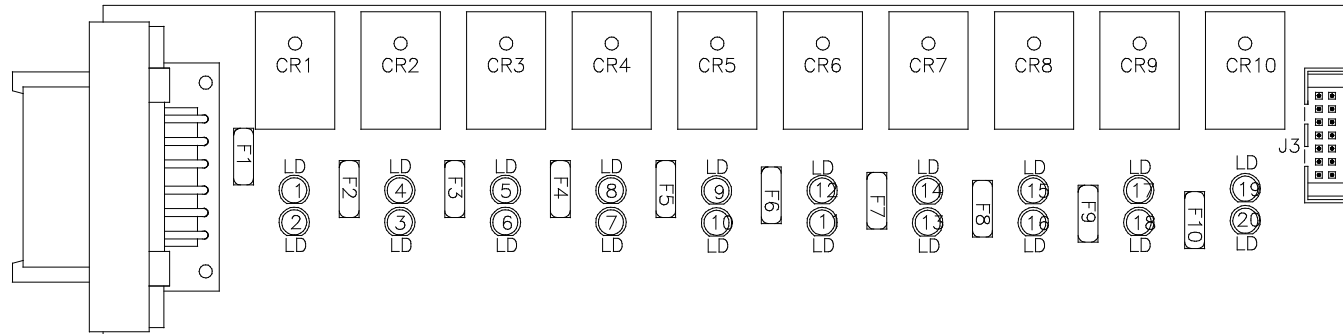

REAR AIR
OUTPUT
LED LAYOUT

LED #	COLOR	INPUT J3	FUSE #	OUTPUT	RELAY #	DESCRIPTION
LED1	YELLOW	PIN 13	---	---	CR1	TAG LIFT (COIL)
LED2	RED	---	FUSE 1	PIN 1	CR1	TAG LIFT (CONTACT)
LED3	RED	---	FUSE 2	PIN 2	CR2	LEFT REAR RAISE (CONTACT)
LED4	YELLOW	PIN 12	---	---	CR2	LEFT REAR RAISE (COIL)
LED5	YELLOW	PIN 11	---	---	CR3	LEFT REAR LOWER (COIL)
LED6	RED	---	FUSE 3	PIN 3	CR3	LEFT REAR LOWER (CONTACT)
LED7	RED	---	FUSE 4	PIN 4	CR4	RIGHT REAR RAISE (CONTACT)
LED8	YELLOW	PIN 10	---	---	CR4	RIGHT REAR RAISE (COIL)
LED9	YELLOW	PIN 9	---	---	CR5	RIGHT REAR LOWER (COIL)
LED10	RED	---	FUSE 5	PIN 5	CR5	RIGHT REAR LOWER (CONTACT)
LED11	RED	---	FUSE 6	PIN 6	CR6	NOT USED
LED12	YELLOW	PIN 8	---	---	CR6	NOT USED
LED13	RED	---	FUSE 7	PIN 10	CR7	TAG LEFT REAR LOWER (CONTACT)
LED14	YELLOW	PIN 7	---	---	CR7	TAG LEFT REAR LOWER (COIL)
LED15	YELLOW	PIN 6	---	---	CR8	TAG RIGHT REAR LOWER (COIL)
LED16	RED	---	FUSE 8	PIN 9	CR8	TAG RIGHT REAR LOWER (CONTACT)
LED17	YELLOW	PIN 5	---	---	CR9	TAG TRAVEL (COIL)
LED18	RED	---	FUSE 9	PIN 7	CR9	TAG TRAVEL (CONTACT)
LED19	YELLOW	PIN 4	---	---	CR10	TRAVEL (COIL)
LED20	RED	---	FUSE 10	PIN 8	CR10	TRAVEL (CONTACT)

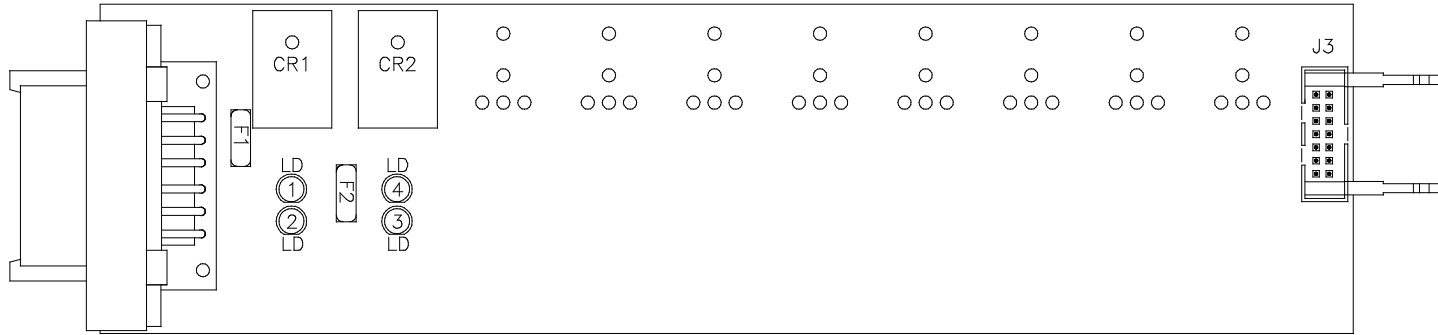

ROOM 2
LED LAYOUT

LED #	COLOR	INPUT J3	FUSE #	OUTPUT	RELAY #	DESCRIPTION
LED1	YELLOW	PIN 13	---	---	CR1	AIR SEAL (COIL)
LED2	RED	---	FUSE 1	PIN 1	CR1	AIR SEAL (CONTACT)
LED3	RED	---	FUSE 2	PIN 2	CR2	VACUUM (CONTACT)
LED4	YELLOW	PIN 12	---	---	CR2	VACUUM (COIL)
LED5	---	---	---	---	---	---
LED6	---	---	---	---	---	---
LED7	---	---	---	---	---	---
LED8	---	---	---	---	---	---
LED9	---	---	---	---	---	---
LED10	---	---	---	---	---	---
LED11	---	---	---	---	---	---
LED12	---	---	---	---	---	---
LED13	---	---	---	---	---	---
LED14	---	---	---	---	---	---
LED15	---	---	---	---	---	---
LED16	---	---	---	---	---	---
LED17	---	---	---	---	---	---
LED18	---	---	---	---	---	---
LED19	---	---	---	---	---	---
LED20	---	---	---	---	---	---