

AP24299
FRONT AIR MODULE

* DESIGNATES PIN 1 OF CONNECTORS

AP26075 (BROWN)

- PIN
- 1 N/C
 - 2 BLK(W1500) LEFT FRONT RAISE
 - 3 BLK(W1600) LEFT FRONT LOWER
 - 4 BLK(W2500) RIGHT FRONT RAISE
 - 5 BLK(W2600) RIGHT FRONT LOWER
 - 6 BLK(W9700) COMPRESSOR
 - 7 N/C
 - 8 BLK(W1700) TRAVEL
 - 9 N/C
 - 10 N/C
 - 11 WHT(W6254) GROUND
 - 12 N/C

AP26075 (GRAY)

- PIN
- 1 RED(W6800) SW BATT
 - 2 RED(W6800) SW BATT
 - 3 GRN(W6230) GND
 - 4 GRN(W6230) GND

AP26075 (BLACK)

- PIN
- 1 N/C
 - 2 N/C
 - 3 RED(W6800) SW BATTERY
 - 4 GRN(W6230) GROUND
 - 5 CAN SHIELD
 - 6 N/C
 - 7 GRN CAN LOW
 - 8 YEL CAN HI

AP26074 CN9(BLACK)

- PIN
- 1 WHT(W7696) SYSTEM WAKE UP
 - 2 N/C
 - 3 RED(W6800) SW BATTERY
 - 4 GRN(W6230) GROUND
 - 5 CAN SHIELD
 - 6 RED(W6110) IGNITION
 - 7 GRN CAN LOW
 - 8 YEL CAN HI

AP26074 CN10(GRAY)

- PIN
- 1 N/C
 - 2 N/C
 - 3 N/C
 - 4 N/C
 - 5 N/C
 - 6 N/C
 - 7 N/C
 - 8 N/C

AP26074 CN12(GRAY)

- PIN
- 1 N/C
 - 2 N/C
 - 3 N/C
 - 4 N/C
 - 5 N/C
 - 6 WHT(W6236) GROUND
 - 7 BLK(W6800) SW. BATTERY
 - 8 N/C
 - 9 N/C
 - 10 BLK(W2210) RIGHT FRONT PSW
 - 11 BLK(W7521) TAG DUMP SWITCH
 - 12 N/C

AP26074 CN11(GREEN)

- PIN
- 1 N/C
 - 2 N/C
 - 3 N/C
 - 4 N/C
 - 5 N/C
 - 6 WHT(W6235) GROUND
 - 7 N/C
 - 8 N/C
 - 9 N/C
 - 10 BLK(W1210) LEFT FRONT PSW
 - 11 N/C
 - 12 N/C

		HWH I-80 EXIT 267 SOUTH RT 1 MOSCOW, IOWA 52760	
		SCALE 1:3	DATE 20FEB04
		DRAWN BY .	
1	28JUL06	REMOVED RM2 LOCKS	
NO.	DATE	REVISION	
		SYSTEM SCHEMATIC ELEC	
THE INFORMATION DISCLOSED ON THIS DRAWING IS CONFIDENTIAL AND MUST NOT BE DISCLOSED OR USED IN ANY MANNER WHICH WILL BE DETRIMENTAL TO THE HWH CORPORATION			DRAWING NUMBER MP89216 A/U

AP29411
CENTRAL CONTROL/ROOM 1
MODULES

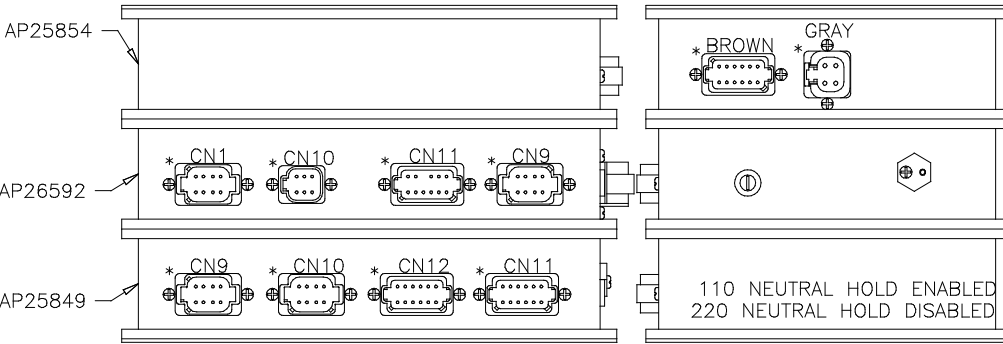

- AP25854 (BROWN)
PIN
- 1 BLK(W5050) CYLINDER EXTEND 1
 - 2 BLK(W5150) CYLINDER RETRACT 1
 - 3 N/C
 - 4 N/C
 - 5 BLK(W5051) CYLINDER EXTEND 2
 - 6 BLK(W5151) CYLINDER RETRACT 2
 - 7 BLK(W5600) AIR SEAL ROOM 1
 - 8 BLK(W5650) VACUUM ROOM 1
 - 9 BLK(W5301) NOT USED
 - 10 BLK(W5201) NOT USED
 - 11 WHT(W6230) GROUND
 - 12 N/C

- AP25854 (GRAY)
PIN
- 1 RED(W6800) SW BATT
 - 2 RED(W6800) SW BATT
 - 3 GRN(W6230) GROUND
 - 4 GRN(W6230) GROUND

- AP26592 CN1(BLACK)
PIN
- 1 WHT(W7696) SYSTEM WAKE UP
 - 2 N/C
 - 3 RED(W6800) SW BATT
 - 4 GRN(W6230) GND
 - 5 CAN SHIELD
 - 6 RED(W6110) IGNITION
 - 7 GRN CAN LOW
 - 8 YEL CAN HI

- AP26592 CN10(GRAY)
PIN
- 1 BLK(W7599) SWITCH LIGHT CONTROL
 - 2 RED(W6100) RESET OUT
 - 3 BLK(W7550) RESET IN
 - 4 RED(W6121) WARN LIGHT SUPPLY
 - 5 WHT(W6230) SWITCH LIGHT SUPPLY
 - 6 BLK(W7699) WARN LIGHT/BUZZER CONTROL

- AP26592 CN11(GRAY)
PIN
- 1 RED(W6110) IGNITION
 - 2 N/C
 - 3 N/C
 - 4 N/C
 - 5 RED(W6120) IGNITION
 - 6 RED(W6100) HOUSE BATTERY
 - 7 GRN(W6230) GROUND
 - 8 WHT(W9961) NEUTAL HOLD
 - 9 WHT(W9955) NEUTRAL HOLD
 - 10 N/C
 - 11 WHT(W9000) PARK BRAKE SWITCH
 - 12 RED(W6101) HOUSE BATTERY

- AP26592 CN9(GREEN)
PIN
- 1 BLK(W8500) MASTER RELAY CNTRL
 - 2 BLK(W8100) SYSTEM PSW.
 - 3 N/C
 - 4 BLK(W8600) PMP RELAY CNTRL
 - 5 BLK(W9900) SPEED SWITCH
 - 6 BLK(W9901) SW BATT FROM PUMP RELAY
 - 7 N/C
 - 8 N/C

- AP25849 CN9(BLACK)
PIN
- 1 WHT(W7696) SYSTEM WAKE UP
 - 2 N/C
 - 3 RED(W6800) SW BATTERY
 - 4 GRN(W6230) GROUND
 - 5 CAN SHIELD
 - 6 RED(W6110) IGNITION
 - 7 GRN CAN LOW
 - 8 YEL CAN HI

- AP25849 CN10(GRAY)
PIN
- 1 N/C
 - 2 WHT(W7510) READY TO OPERATE
 - 3 WHT(W7530) PUMP
 - 4 WHT(W7501) EXTEND (ROOM 1)
 - 5 WHT(W7502) RETRACT (ROOM 1)
 - 6 RED(W6805) SW BATTERY
 - 7 WHT(W7696) SYSTEM WAKE UP
 - 8 GRN(W6230) GROUND

- AP25849 CN12(GRAY)
PIN
- 1 N/C
 - 2 BLK(W5701) FRONT ROOM OUT
 - 3 N/C
 - 4 N/C
 - 5 N/C
 - 6 WHT(W6230) GROUND
 - 7 RED(W6121) SW BATTERY
 - 8 N/C
 - 9 N/C
 - 10 BLK(W5703) UPPER FRONT ROOM IN
 - 11 BLK(W7695) NOT USED
 - 12 N/C

- AP25849 CN 11 (GREEN)
PIN
- 1 N/C
 - 2 N/C
 - 3 N/C
 - 4 N/C
 - 5 N/C
 - 6 WHT(W6231) GROUND
 - 7 N/C
 - 8 BLK(W5651) VACUUM SENSE ROOM 1
 - 9 N/C
 - 10 N/C
 - 11 N/C
 - 12 N/C

AP26603
REAR AIR/ROOM 2
MODULE

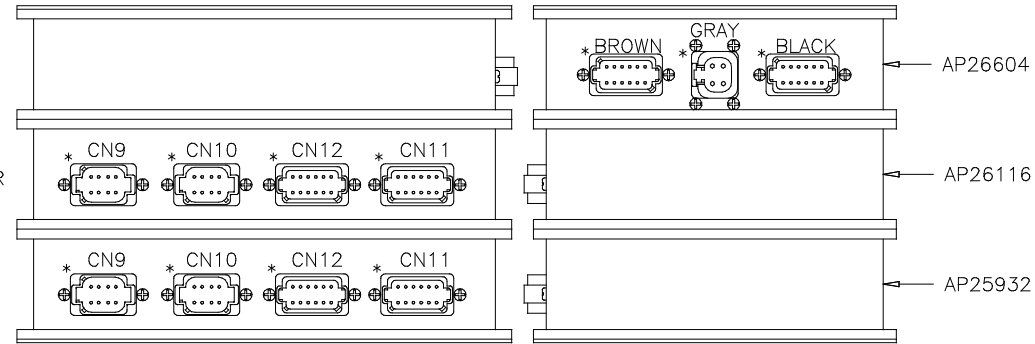

AP26604 (BROWN)
PIN
1 BLK(W5650) VACUUM
2 BLK(W5600) AIR SEAL
3 N/C
4 N/C
5 N/C
6 N/C
7 N/C
8 N/C
9 N/C
10 N/C
11 WHT(W6230) GROUND
12 N/C

AP26604 (GRAY)
PIN
1 RED (W6800) SW BATT
2 RED (W6800) SW BATT
3 GRN (W6230) GND
4 GRN (W6230) GND

AP26604 (BLACK)
PIN
1 N/C
2 BLK(W4500) LEFT REAR RAISE
3 BLK(W4600) LEFT REAR LOWER
4 BLK(W3500) RIGHT REAR RAISE
5 BLK(W3600) RIGHT REAR LOWER
6 N/C
7 N/C
8 N/C
9 N/C
10 N/C
11 WHT(W6258) GROUND
12 N/C

AP26116 CN9(BLACK)
PIN
1 N/C
2 N/C
3 N/C
4 N/C
5 N/C
6 N/C
7 N/C
8 N/C

AP26116 CN10(GRAY)
PIN
1 N/C
2 N/C
3 N/C
4 N/C
5 N/C
6 N/C
7 N/C
8 N/C

AP26116 CN12(GRAY)
PIN
1 N/C
2 N/C
3 BLK (W3215) SYSTEM PRESS SW.
4 N/C
5 N/C
6 WHT (W6231) GROUND
7 N/C
8 N/C
9 N/C
10 N/C
11 N/C
12 N/C

AP26116 CN11(GREEN)
PIN
1 N/C
2 BLK(W4210) LEFT REAR PRESS SW.
3 BLK(W3210) RIGHT REAR PRESS SW.
4 N/C
5 N/C
6 WHT(W6232) GROUND
7 N/C
8 N/C
9 N/C
10 N/C
11 N/C
12 N/C

AP25932 CN9(BLACK)
PIN
1 WHT(W7696) SYSTEM WAKE UP
2 N/C
3 RED(W6800) SW BATTERY
4 GRN(W6230) GROUND
5 CAN SHIELD
6 RED(W6110) IGNITION
7 GRN CAN LOW
8 YEL CAN HI

AP25932 CN10(GRAY)
PIN
1 N/C
2 WHT(W7510) READY TO OPERATE
3 WHT(W7530) PUMP
4 WHT(W7501) EXTEND (ROOM 2)
5 WHT(W7502) RETRACT (ROOM 2)
6 RED(W6805) SW BATTERY
7 WHT(W7696) SYSTEM WAKE UP
8 GRN(W6230) GROUND

AP25932 CN12(GRAY)
PIN
1 N/C
2 BLK(W5701) FRONT ROOM OUT
3 N/C
4 N/C
5 N/C
6 WHT(W6230) GROUND
7 RED(W6121) SW BATTERY
8 N/C
9 N/C
10 BLK(W5703) UPPER FRONT ROOM IN
11 N/C
12 N/C

AP25932 CN 11(GREEN)
PIN
1 N/C
2 N/C
3 N/C
4 N/C
5 N/C
6 WHT(W6231) GROUND
7 N/C
8 BLK(W5651) VACUUM SENSE ROOM 2
9 N/C
10 N/C
11 N/C
12 N/C

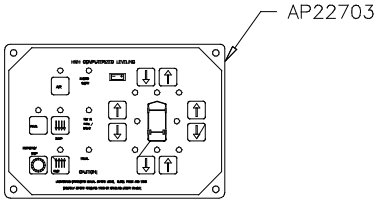

5 1

- PIN
- 1 YELLOW CAN HI
 - 2 GREEN CAN LOW
 - 3 CAN SHIELD
 - 4 GRN (W6230) GROUND
 - 5 RED (W6800) SW. BATTERY

120 OHM
TERMINATION
RESISTOR
PART OF OEM
PROVIDED TRUNK
HARNESS #72308.



OEM #72308

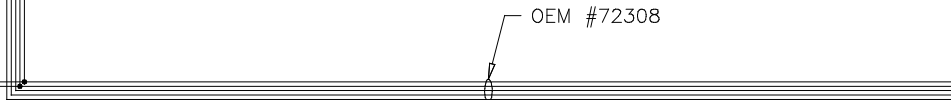

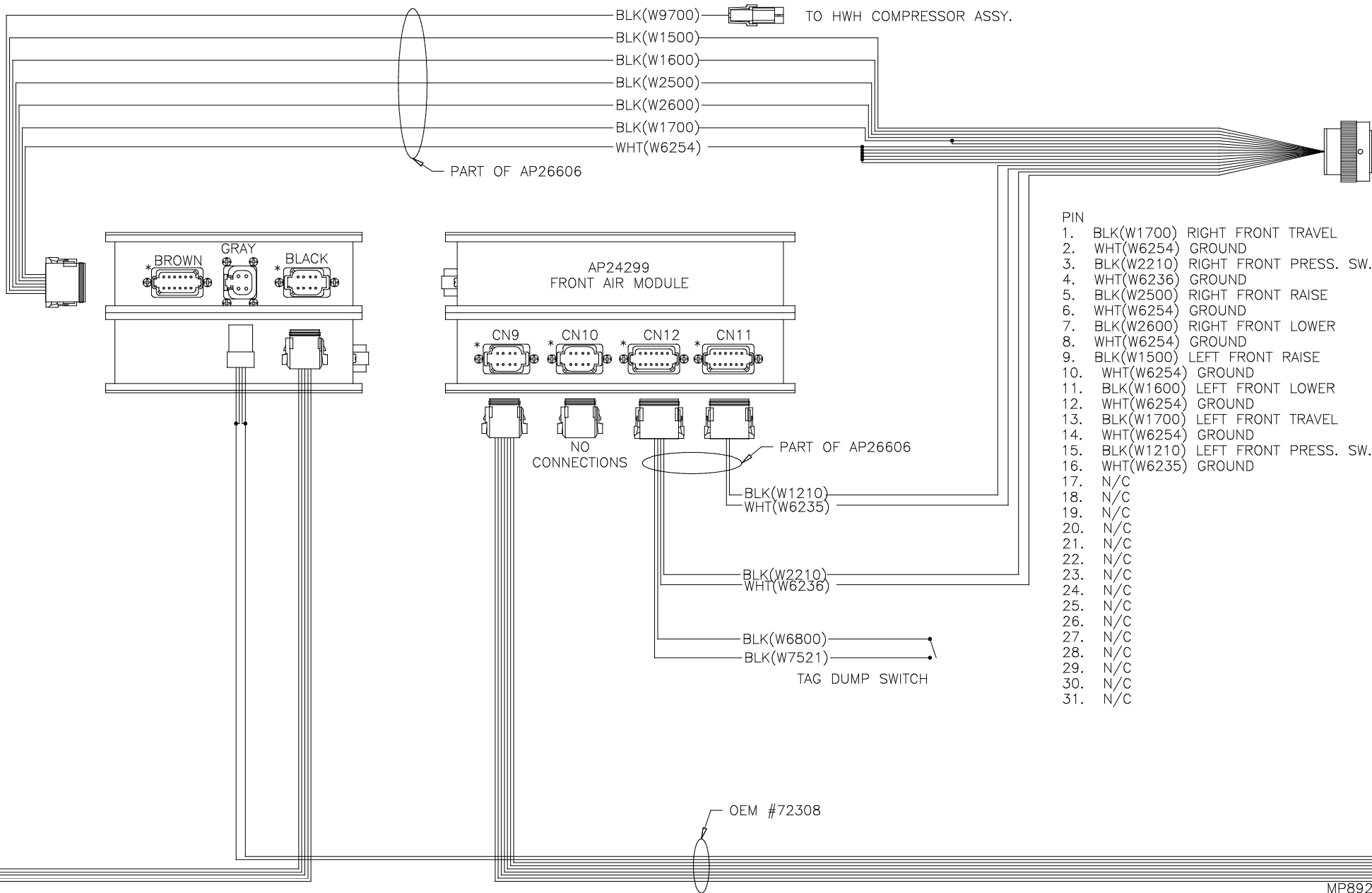

- PIN
1. BLK(W1700) RIGHT FRONT TRAVEL
 2. WHT(W6254) GROUND
 3. BLK(W2210) RIGHT FRONT PRESS. SW.
 4. WHT(W6236) GROUND
 5. BLK(W2500) RIGHT FRONT RAISE
 6. WHT(W6254) GROUND
 7. BLK(W2600) RIGHT FRONT LOWER
 8. WHT(W6254) GROUND
 9. BLK(W1500) LEFT FRONT RAISE
 10. WHT(W6254) GROUND
 11. BLK(W1600) LEFT FRONT LOWER
 12. WHT(W6254) GROUND
 13. BLK(W1700) LEFT FRONT TRAVEL
 14. WHT(W6254) GROUND
 15. BLK(W1210) LEFT FRONT PRESS. SW.
 16. WHT(W6235) GROUND
 17. N/C
 18. N/C
 19. N/C
 20. N/C
 21. N/C
 22. N/C
 23. N/C
 24. N/C
 25. N/C
 26. N/C
 27. N/C
 28. N/C
 29. N/C
 30. N/C
 31. N/C

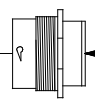

- PIN
1. RIGHT FRONT TRAVEL
 2. GROUND
 3. RIGHT FRONT PRESS. SW.
 4. GROUND
 5. RIGHT FRONT RAISE
 6. GROUND
 7. RIGHT FRONT LOWER
 8. GROUND
 9. LEFT FRONT RAISE
 10. GROUND
 11. LEFT FRONT LOWER
 12. GROUND
 13. LEFT FRONT TRAVEL
 14. GROUND
 15. LEFT FRONT PRESS. SW.
 16. GROUND
 17. SYSTEM PRESS. SW.
 18. GROUND
 19. N/C
 20. N/C
 21. N/C
 22. N/C
 23. N/C
 24. N/C
 25. N/C
 26. N/C
 27. N/C
 28. N/C
 29. N/C
 30. N/C
 31. N/C

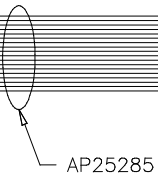

AP25285

FRONT AIR
MANIFOLD
CONNECTIONS

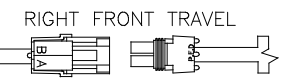
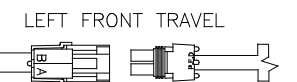
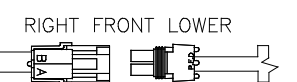
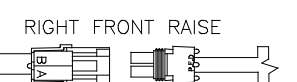
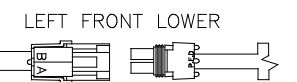
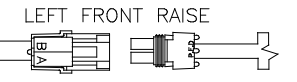

SYSTEM PRESSURE SWITCH
(NOT USED)

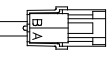

RIGHT FRONT PRESSURE SWITCH

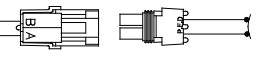

LEFT FRONT PRESSURE SWITCH

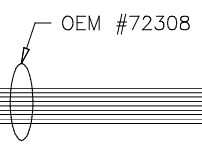
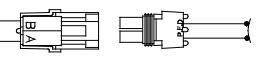

OEM #72308

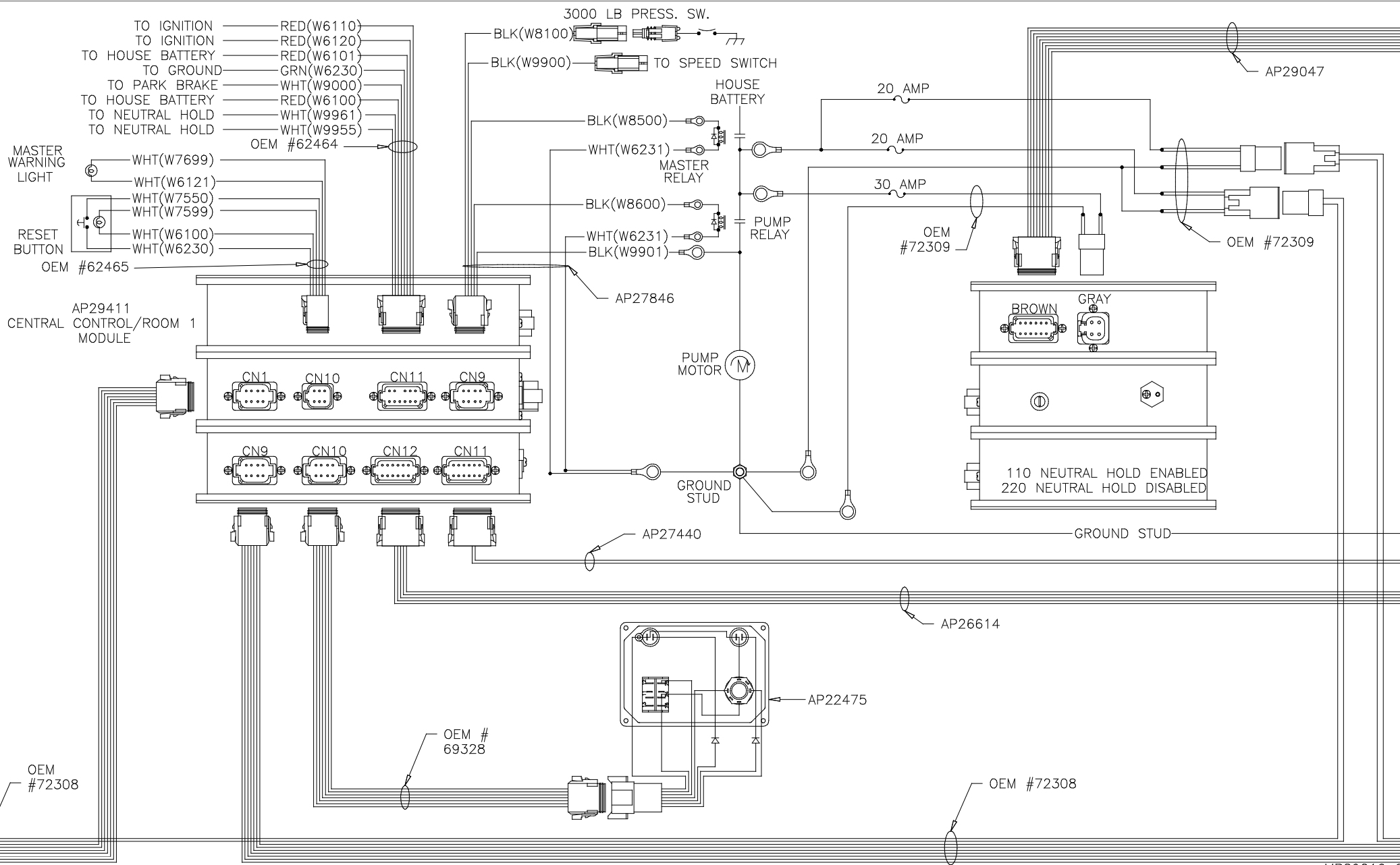

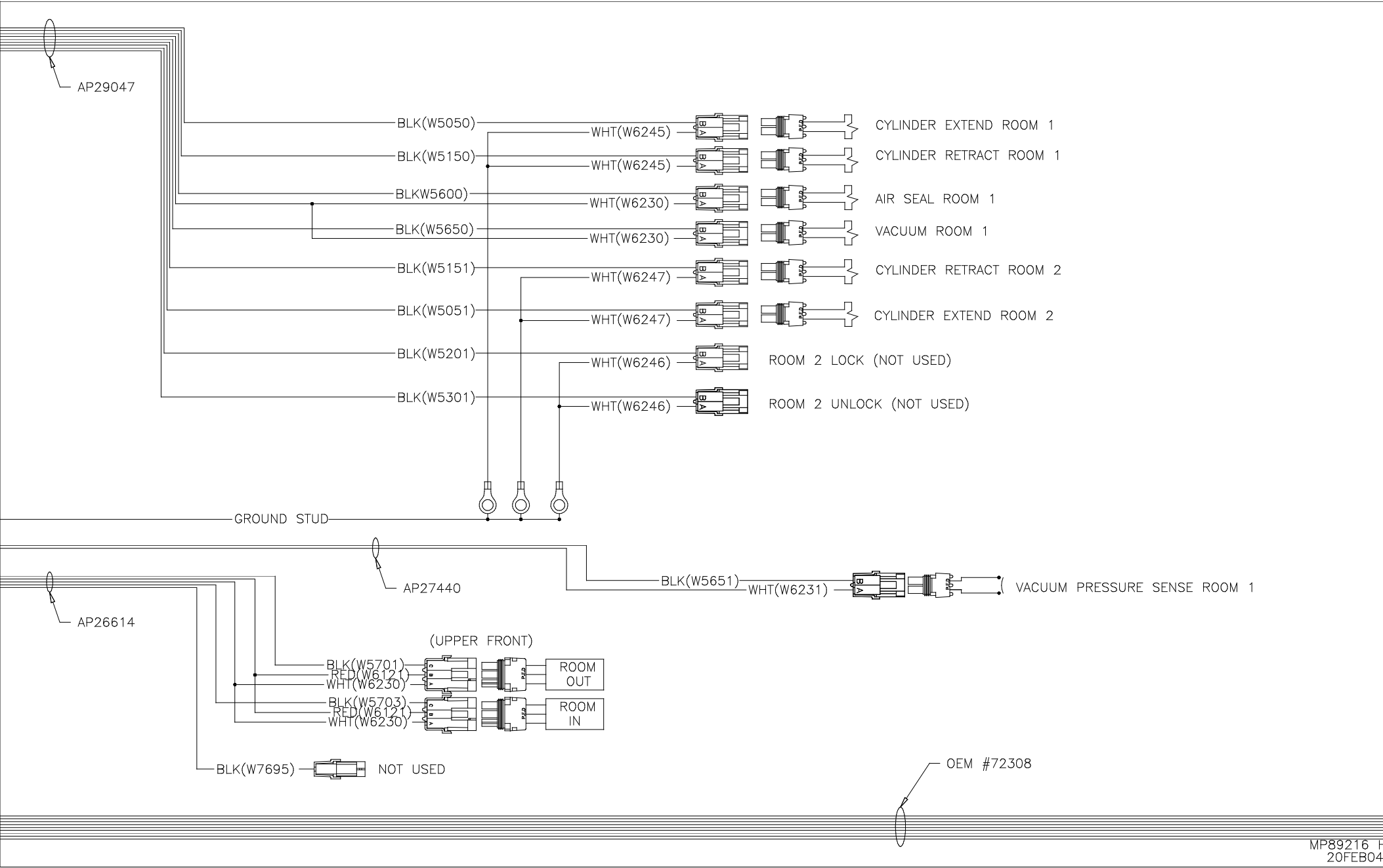

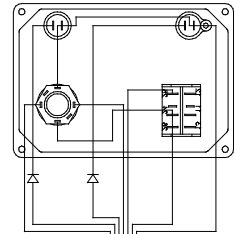

AP22475

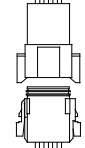

OEM #69328

OEM #72308

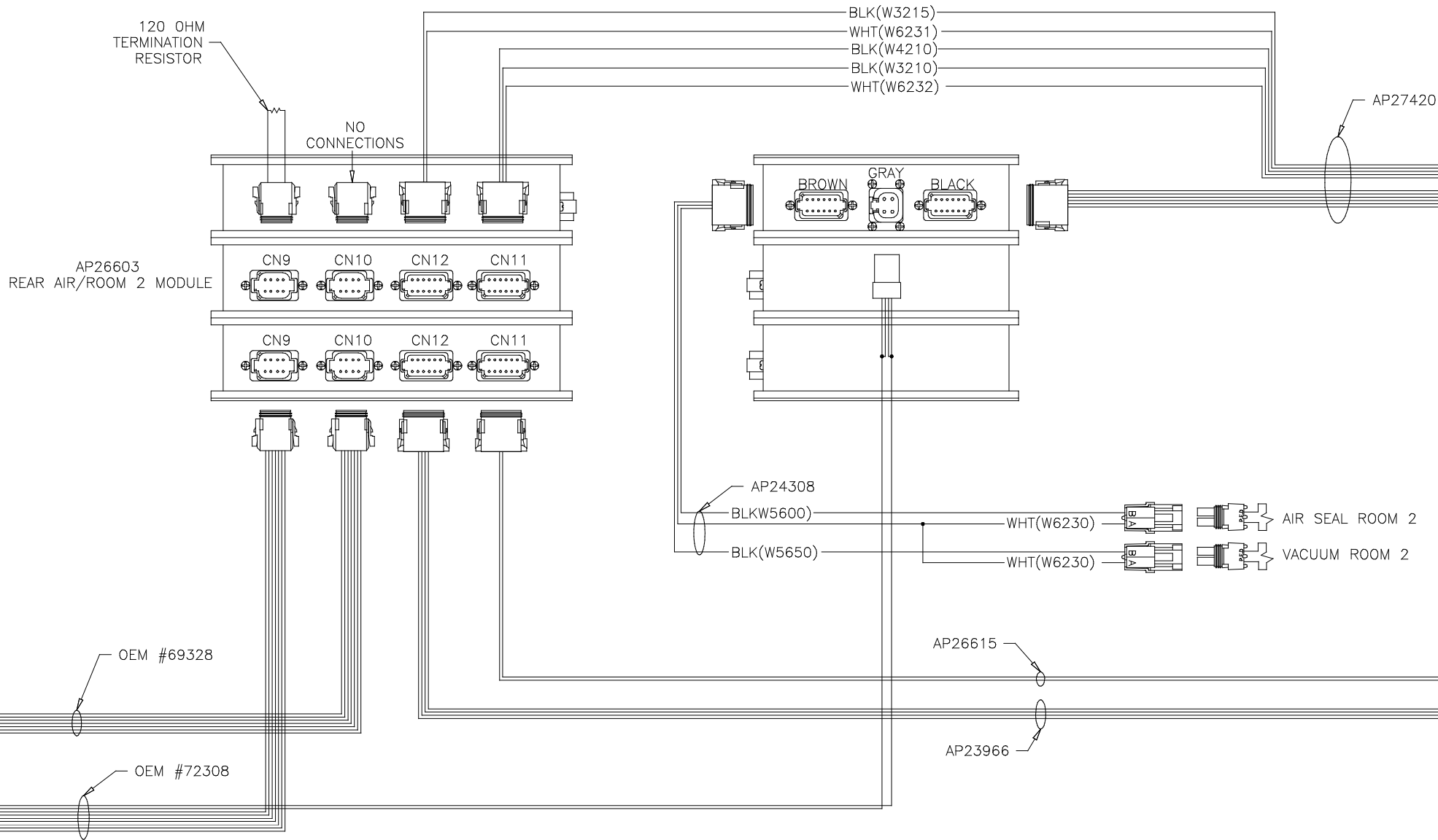

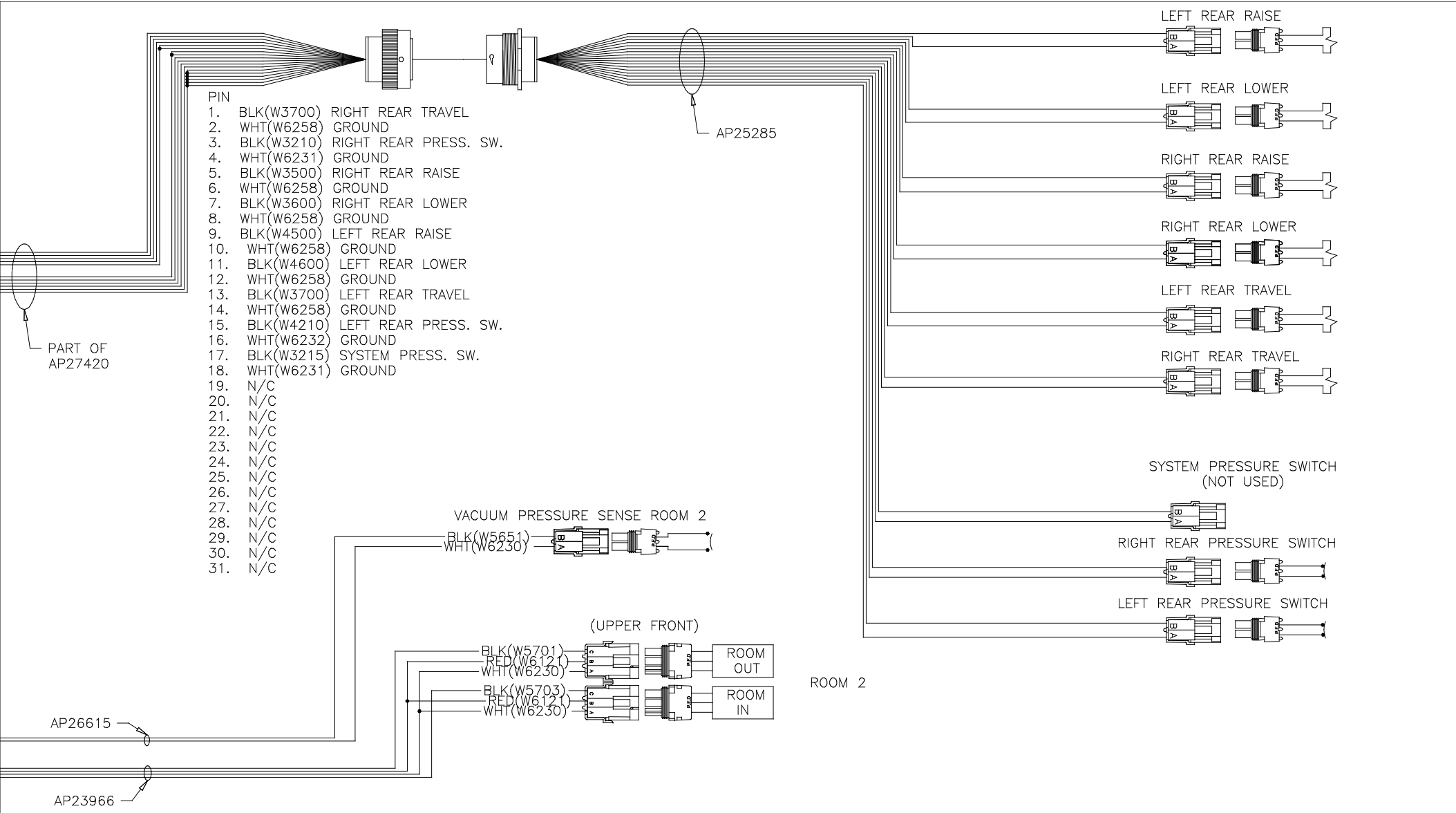

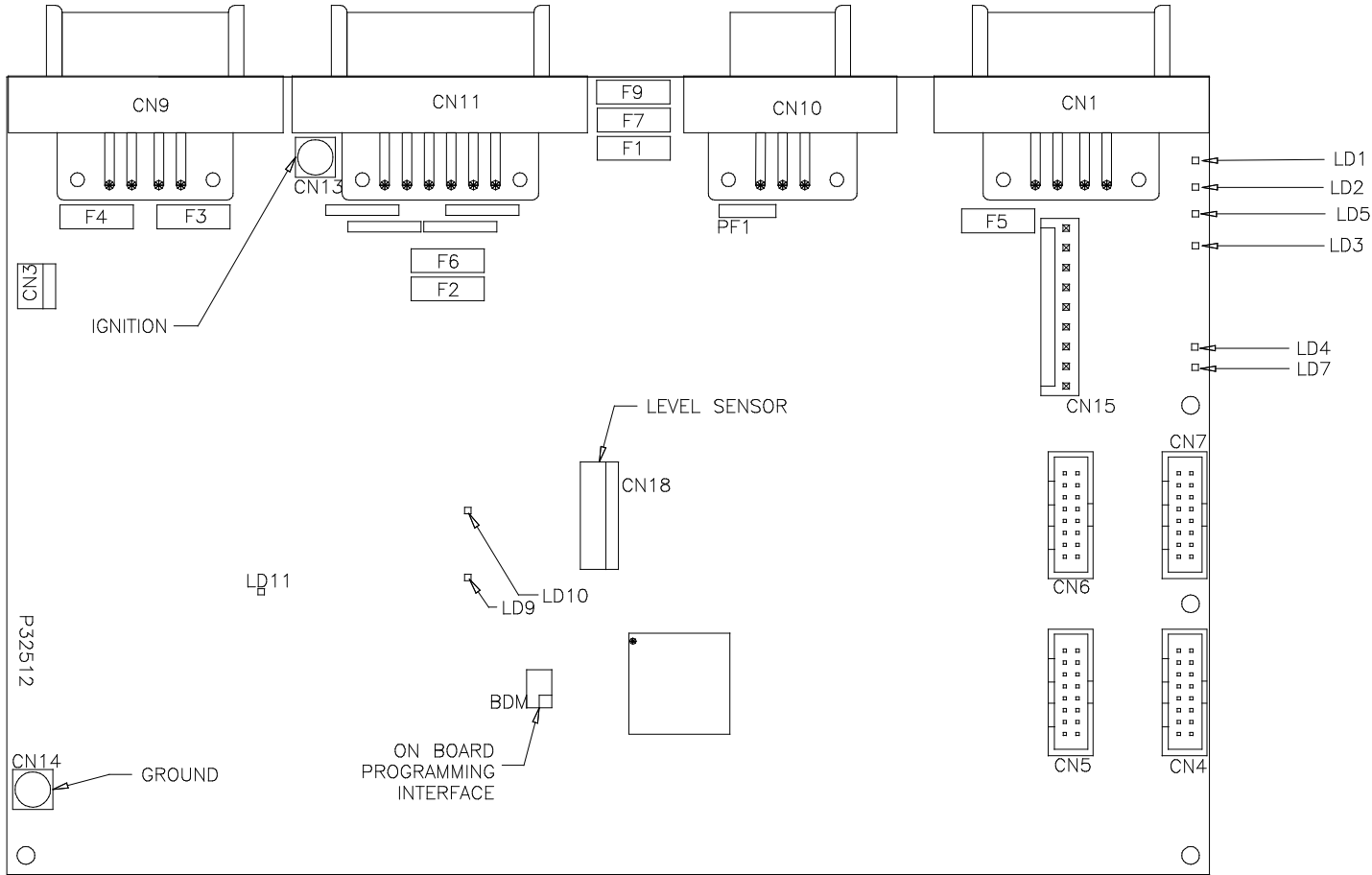

CENTRAL
CONTROL MODULE
LED LAYOUT
EFFECTIVE APPROXIMATELY
SEPTEMBER, 2005

LED #	CONNECTOR	COLOR	DESCRIPTION
LED 1	CN 9 PIN 1	RED	MASTER RELAY
LED 2	CN 9 PIN 4	RED	PUMP RELAY
LED 3	CN 1 PIN 3	RED	SW 12V
LED 4	CN 11 PIN 12	RED	ENGINE BATT
LED 5	CN 9 PIN 5	RED	SPEED SWITCH
LED 7	CN 1 PIN 7 & 8	RED	LINK LIGHT
LED 8	CN 11 PIN 8 & 9	RED	NEUTRAL HOLD
LED 9	NOT USED	NOT USED	NOT USED
LED 10	CN9 PIN 2	RED	3000 LBS. PSW
LED 11	CN11 PIN 11	RED	PARK BRAKE

FUSE #	DESCRIPTION
PF1	RESET OUT
F7	ACCESSORY
F1	IGNITION
F2	HOUSE BATTERY
F3	MASTER RELAY
F4	PUMP RELAY
F5	SW. BATT TO CAN MODULES
F6	ENGINE BATTERY
F9	NOT USED

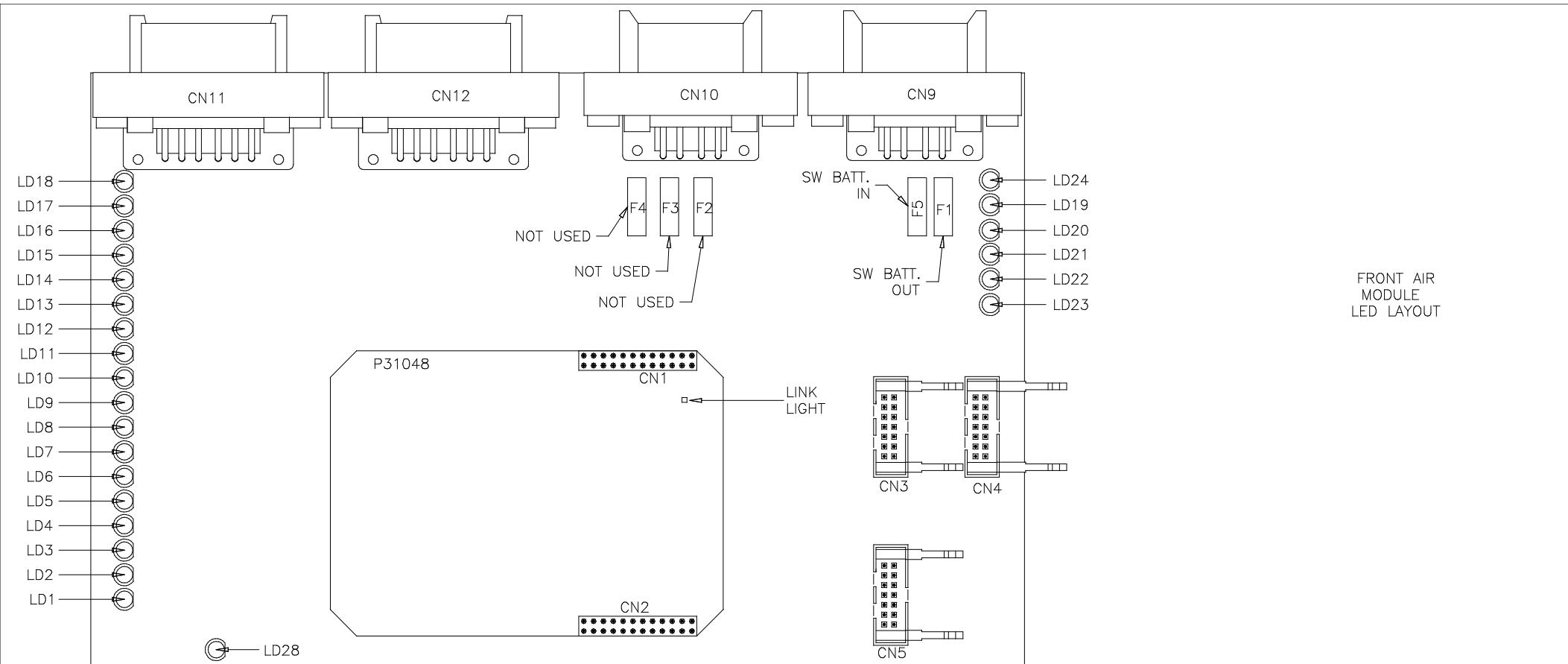

FRONT AIR
MODULE
LED LAYOUT

LED #	CONNECTOR	COLOR	DESCRIPTION	LED #	CONNECTOR	COLOR	DESCRIPTION
LED 1	NOT USED	RED	NOT USED	LED 16	NOT USED	GREEN	NOT USED
LED 2	NOT USED	RED	NOT USED	LED 17	NOT USED	GREEN	NOT USED
LED 3	NOT USED	GREEN	NOT USED	LED 18	NOT USED	GREEN	NOT USED
LED 4	NOT USED	YELLOW	NOT USED	LED 19	CN11/CN12 PIN 7	RED	12V OUTPUT
LED 5	NOT USED	YELLOW	NOT USED	LED 20	NOT USED	RED	NOT USED
LED 6	NOT USED	YELLOW	NOT USED	LED 21	NOT USED	RED	NOT USED
LED 7	NOT USED	GREEN	NOT USED	LED 22	NOT USED	RED	NOT USED
LED 8	NOT USED	GREEN	NOT USED	LED 23	NOT USED	RED	NOT USED
LED 9	CN11 PIN 10	GREEN	LEFT FRONT PSW	LED 24	NOT USED	RED	NOT USED
LED 10	CN12 PIN 10	GREEN	RIGHT FRONT PSW	LED 28	CN 12 PIN 11	RED	TAG DUMP
LED 11	NOT USED	YELLOW	NOT USED				
LED 12	NOT USED	YELLOW	NOT USED				
LED 13	NOT USED	YELLOW	NOT USED				
LED 14	NOT USED	YELLOW	NOT USED				
LED 15	NOT USED	GREEN	NOT USED				

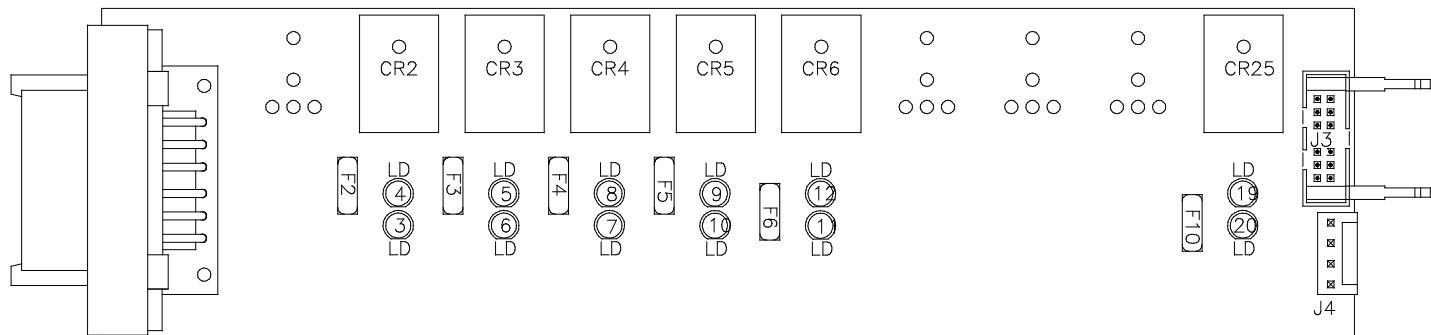

FRONT AIR
LED LAYOUT

LED #	COLOR	INPUT J3	FUSE #	OUTPUT	RELAY #	DESCRIPTION
LED1	---	---	---	---	---	---
LED2	---	---	---	---	---	---
LED3	RED	---	FUSE 2	PIN 2	CR2	LEFT FRONT RAISE (CONTACT)
LED4	YELLOW	PIN 12	---	---	CR2	LEFT FRONT RAISE (COIL)
LED5	YELLOW	PIN 11	---	---	CR3	LEFT FRONT LOWER (COIL)
LED6	RED	---	FUSE 3	PIN 3	CR3	LEFT FRONT LOWER (CONTACT)
LED7	RED	---	FUSE 4	PIN 4	CR4	RIGHT FRONT RAISE (CONTACT)
LED8	YELLOW	PIN 10	---	---	CR4	RIGHT FRONT RAISE (COIL)
LED9	YELLOW	PIN 9	---	---	CR5	RIGHT FRONT LOWER (COIL)
LED10	RED	---	FUSE 5	PIN 5	CR5	RIGHT FRONT LOWER (CONTACT)
LED11	RED	---	FUSE 6	PIN 6	CR6	COMPRESSOR (CONTACT)
LED12	YELLOW	PIN 8	---	---	CR6	COMPRESSOR (COIL)
LED13	---	---	---	---	---	---
LED14	---	---	---	---	---	---
LED15	---	---	---	---	---	---
LED16	---	---	---	---	---	---
LED17	---	---	---	---	---	---
LED18	---	---	---	---	---	---
LED19	YELLOW	PIN 4	---	---	CR25	TRAVEL (COIL)
LED20	RED	---	FUSE 10	PIN 8	CR25	TRAVEL (CONTACT)

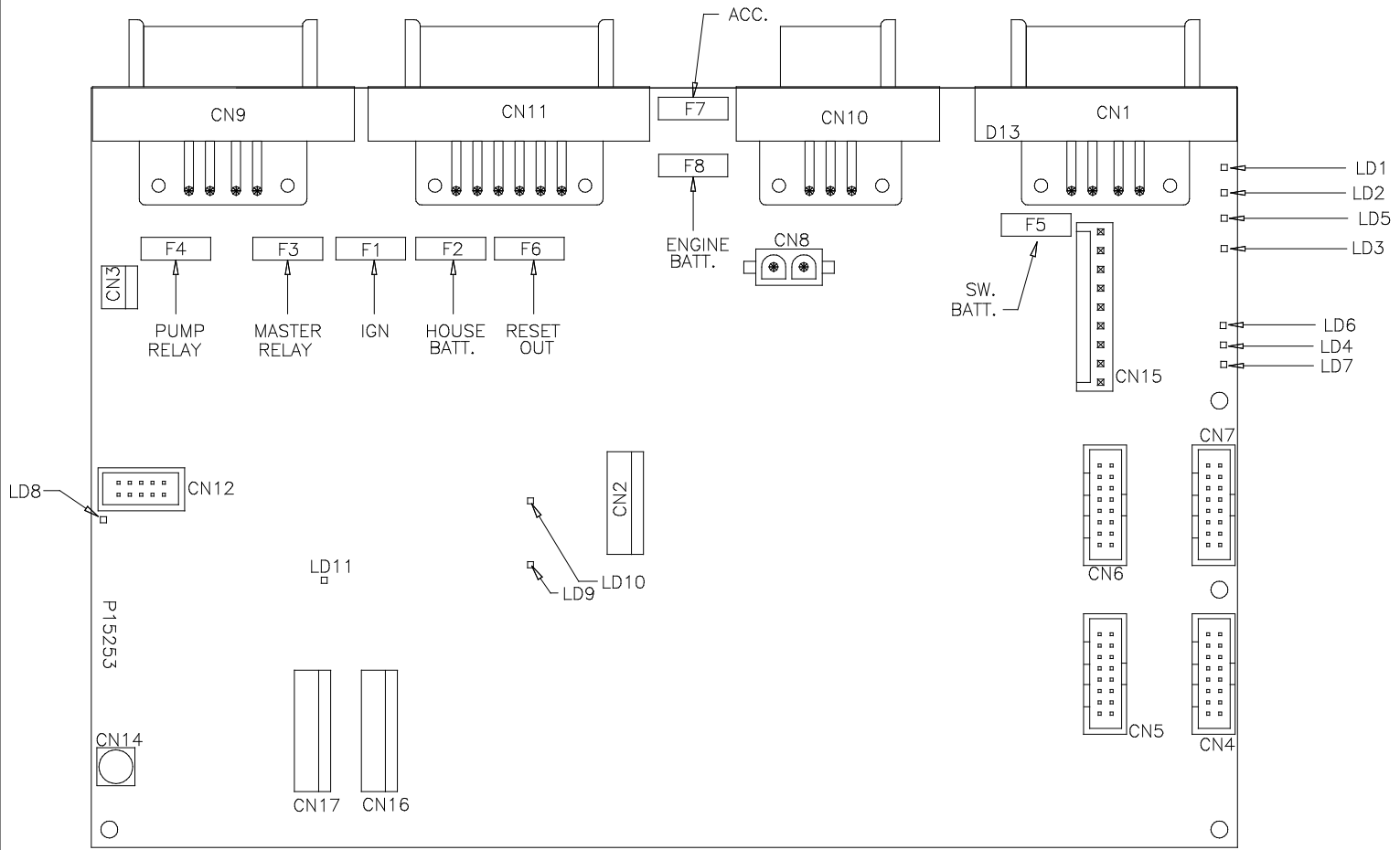

CENTRAL
CONTROL MODULE
LED LAYOUT

REPLACED BY P32512 PCB
APPROXIMATELY SEPTEMBER, 2005

SEE MP89216 L FOR P32512
LAYOUT INFO

LED #	CONNECTOR	COLOR	DESCRIPTION
LED 1	CN 9 PIN 1	RED	MASTER RELAY
LED 2	CN 9 PIN 4	RED	PUMP RELAY
LED 3	CN 1 PIN 3	RED	SW 12V
LED 4	CN 11 PIN 12	RED	ENGINE BATT
LED 5	CN 9 PIN 5	RED	SPEED SWITCH
LED 6	NOT USED	NOT USED	NOT USED

LED #	CONNECTOR	COLOR	DESCRIPTION
LED 7	CN 1 PIN 7 & 8	RED	LINK LIGHT
LED 8	CN 11 PIN 8 & 9	RED	NEUTRAL HOLD
LED 9	NOT USED	NOT USED	NOT USED
LED 10	CN9 PIN 2	RED	3000 LBS. PSW
LED 11	CN11 PIN 11	RED	PARK BRAKE

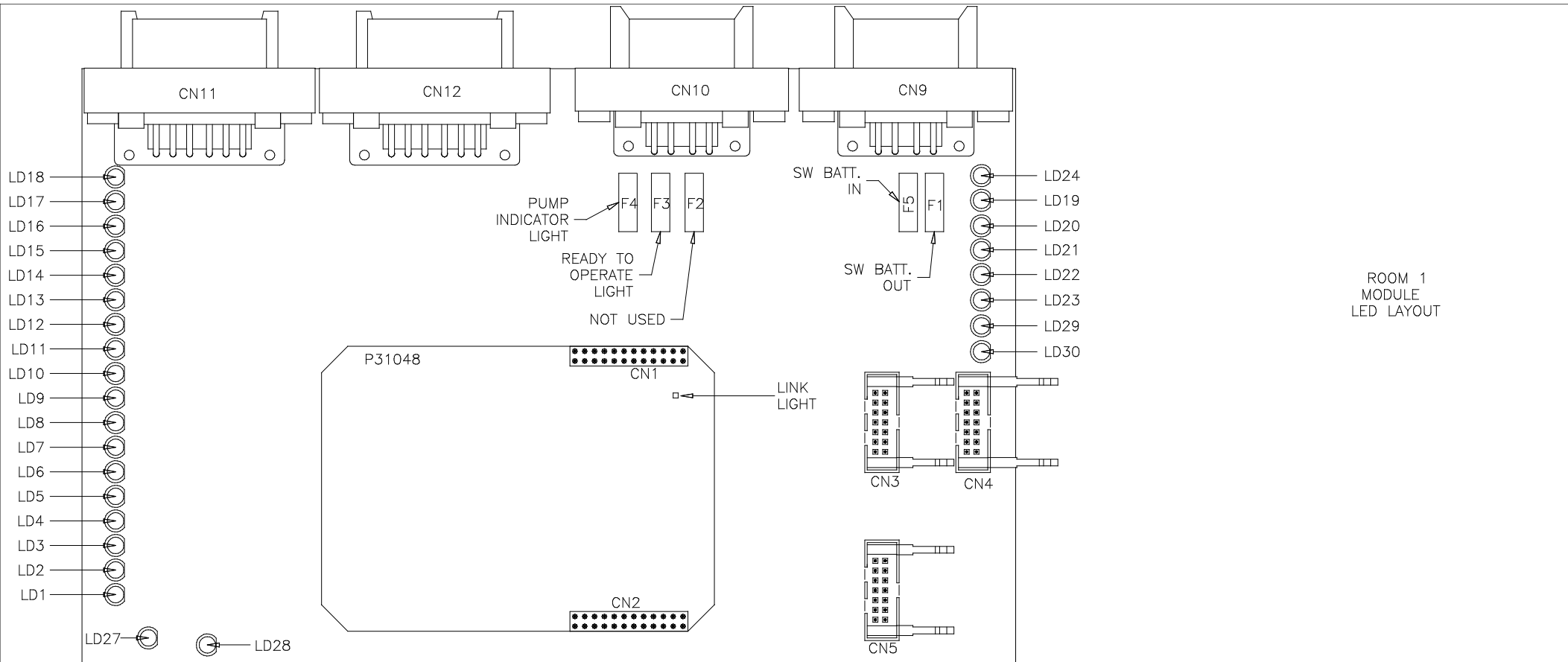

LED #	CONNECTOR	COLOR	DESCRIPTION	LED #	CONNECTOR	COLOR	DESCRIPTION
LED 1	CN10 PIN 4	RED	EXTEND	LED 16	NOT USED	GREEN	NOT USED
LED 2	CN10 PIN 5	RED	RETRACT	LED 17	NOT USED	GREEN	NOT USED
LED 3	NOT USED	GREEN	NOT USED	LED 18	NOT USED	GREEN	NOT USED
LED 4	NOT USED	YELLOW	NOT USED	LED 19	CN11/CN12 PIN 7	RED	12V OUTPUT
LED 5	NOT USED	YELLOW	NOT USED	LED 20	CN9 PIN 3	RED	SW BATT
LED 6	CN12 PIN 2	YELLOW	FRONT ROOM OUT	LED 21	CN10 PIN 3	RED	PUMP INDICATOR
LED 7	NOT USED	GREEN	NOT USED	LED 22	CN10 PIN 2	RED	READY TO OPERATE
LED 8	NOT USED	GREEN	NOT USED	LED 23	NOT USED	RED	NOT USED
LED 9	NOT USED	GREEN	NOT USED	LED 24	CN10 PIN 7	RED	SYSTEM WAKE UP
LED 10	CN12 PIN 10	GREEN	UPPER FRONT ROOM IN	LED 27	CN11 PIN 8	RED	VACUUM SENSE
LED 11	NOT USED	YELLOW	NOT USED	LED 28	NOT USED	RED	NOT USED
LED 12	NOT USED	YELLOW	NOT USED	LED 29	NOT USED	RED	NOT USED
LED 13	NOT USED	YELLOW	NOT USED	LED 30	NOT USED	RED	NOT USED
LED 14	NOT USED	YELLOW	NOT USED				
LED 15	NOT USED	GREEN	NOT USED				

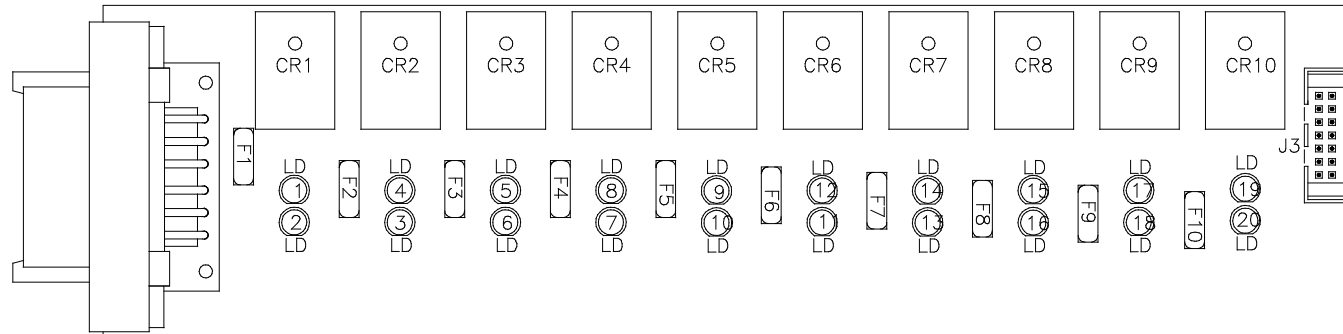

ROOM 1 + 2
LED LAYOUT

LED #	COLOR	INPUT J3	FUSE #	OUTPUT	RELAY #	DESCRIPTION
LED1	YELLOW	PIN 13	---	---	CR1	CYL EXTEND 1 (COIL)
LED2	RED	---	FUSE 1	PIN 1	CR1	CYL EXTEND 1 (CONTACT)
LED3	RED	---	FUSE 2	PIN 2	CR2	CYL RETRACT1 (CONTACT)
LED4	YELLOW	PIN 12	---	---	CR2	CYL RETRACT RM 1 (COIL)
LED5	YELLOW	PIN 11	---	---	CR3	NOT USED
LED6	RED	---	FUSE 3	PIN 3	CR3	NOT USED
LED7	RED	---	FUSE 4	PIN 4	CR4	NOT USED
LED8	YELLOW	PIN 10	---	---	CR4	NOT USED
LED9	YELLOW	PIN 9	---	---	CR5	CYL EXTEND 2 (COIL)
LED10	RED	---	FUSE 5	PIN 5	CR5	CYL EXTEND 2 (CONTACT)
LED11	RED	---	FUSE 6	PIN 6	CR6	CYL RETRACT 2 (CONTACT)
LED12	YELLOW	PIN 8	---	---	CR6	CYL RETRACT 2 (COIL)
LED13	RED	---	FUSE 7	PIN 10	CR7	NOT USED
LED14	YELLOW	PIN 7	---	---	CR7	NOT USED
LED15	YELLOW	PIN 6	---	---	CR8	NOT USED
LED16	RED	---	FUSE8	PIN 9	CR8	NOT USED
LED17	YELLOW	PIN 5	---	---	CR9	AIR SEAL (COIL)
LED18	RED	---	FUSE 9	PIN 7	CR9	AIR SEAL (CONTACT)
LED19	YELLOW	PIN 4	---	---	CR10	VACUUM (COIL)
LED20	RED	---	FUSE 10	PIN 8	CR10	VACUUM (CONTACT)

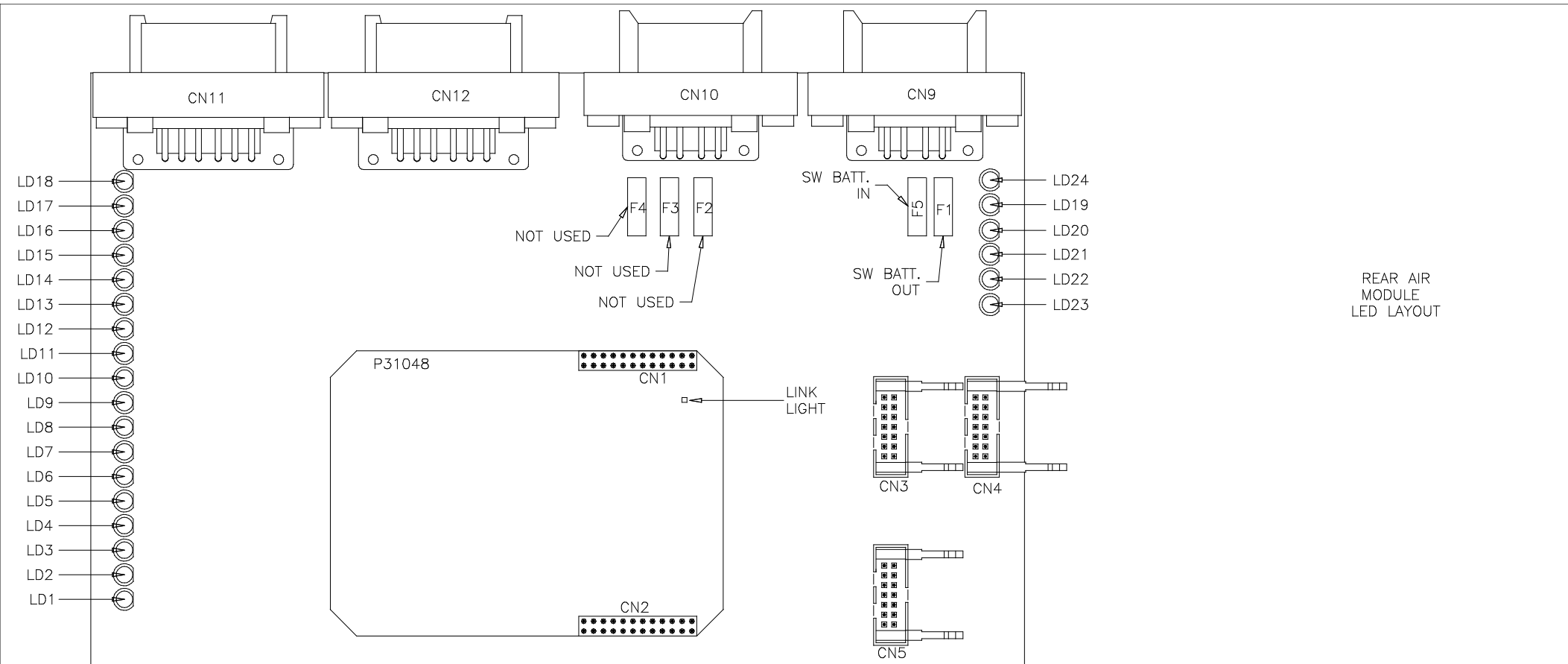

REAR AIR
MODULE
LED LAYOUT

LED #	CONNECTOR	COLOR	DESCRIPTION	LED #	CONNECTOR	COLOR	DESCRIPTION
LED 1	NOT USED	RED	NOT USED	LED 16	NOT USED	GREEN	NOT USED
LED 2	NOT USED	RED	NOT USED	LED 17	NOT USED	GREEN	NOT USED
LED 3	NOT USED	GREEN	NOT USED	LED 18	NOT USED	GREEN	NOT USED
LED 4	NOT USED	YELLOW	NOT USED	LED 19	CN11/CN12 PIN 7	RED	12V OUT
LED 5	CN11 PIN 2	YELLOW	LEFT REAR PRESS. SW.	LED 20	NOT USED	RED	NOT USED
LED 6	NOT USED	YELLOW	NOT USED	LED 21	NOT USED	RED	NOT USED
LED 7	CN11 PIN 3	GREEN	RIGHT REAR PRESS. SW.	LED 22	NOT USED	RED	NOT USED
LED 8	CN12 PIN 3	GREEN	SYSTEM PRESS SW.	LED 23	NOT USED	RED	NOT USED
LED 9	NOT USED	GREEN	NOT USED	LED 24	NOT USED	RED	NOT USED
LED 10	NOT USED	GREEN	NOT USED				
LED 11	NOT USED	YELLOW	NOT USED				
LED 12	NOT USED	YELLOW	NOT USED				
LED 13	NOT USED	YELLOW	NOT USED				
LED 14	NOT USED	YELLOW	NOT USED				
LED 15	NOT USED	GREEN	NOT USED				

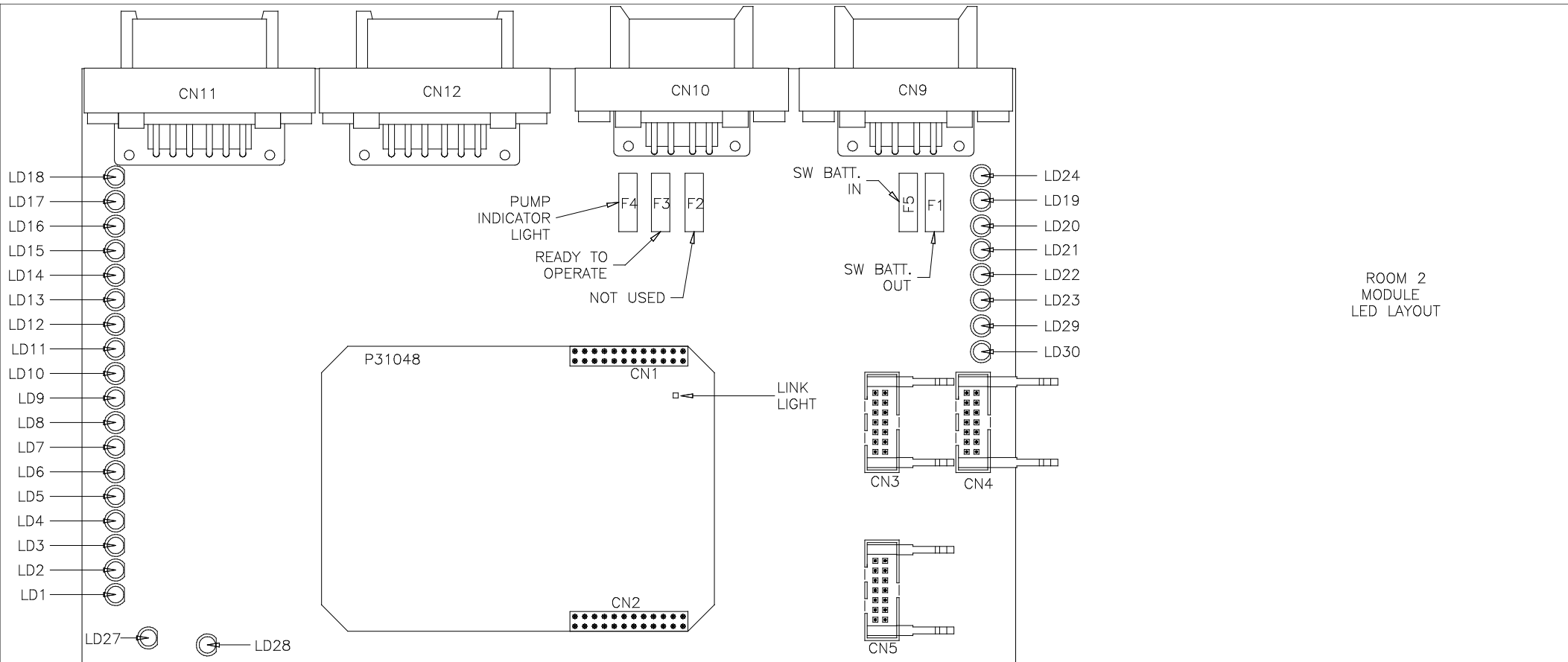

ROOM 2
MODULE
LED LAYOUT

LED #	CONNECTOR	COLOR	DESCRIPTION	LED #	CONNECTOR	COLOR	DESCRIPTION
LED 1	CN10 PIN 4	RED	EXTEND	LED 16	NOT USED	GREEN	NOT USED
LED 2	CN10 PIN 5	RED	RETRACT	LED 17	NOT USED	GREEN	NOT USED
LED 3	NOT USED	GREEN	NOT USED	LED 18	NOT USED	GREEN	NOT USED
LED 4	NOT USED	YELLOW	NOT USED	LED 19	CN11/CN12 PIN 7	RED	12V OUTPUT
LED 5	NOT USED	YELLOW	NOT USED	LED 20	CN9 PIN 3	RED	SW BATT
LED 6	CN12 PIN 2	YELLOW	FRONT ROOM OUT	LED 21	CN10 PIN 3	RED	PUMP INDICATOR
LED 7	NOT USED	GREEN	NOT USED	LED 22	CN10 PIN 2	RED	READY TO OPERATE
LED 8	NOT USED	GREEN	NOT USED	LED 23	NOT USED	RED	NOT USED
LED 9	CN11 PIN 10	GREEN	UPPER REAR ROOM IN	LED 24	CN10 PIN 7	RED	SYSTEM WAKE UP
LED 10	CN12 PIN 10	GREEN	UPPER FRONT ROOM IN	LED 27	NOT USED	RED	NOT USED
LED 11	NOT USED	YELLOW	NOT USED	LED 28	NOT USED	RED	NOT USED
LED 12	NOT USED	YELLOW	NOT USED	LED 29	NOT USED	RED	NOT USED
LED 13	NOT USED	YELLOW	NOT USED	LED 30	NOT USED	RED	NOT USED
LED 14	NOT USED	YELLOW	NOT USED				
LED 15	NOT USED	GREEN	NOT USED				

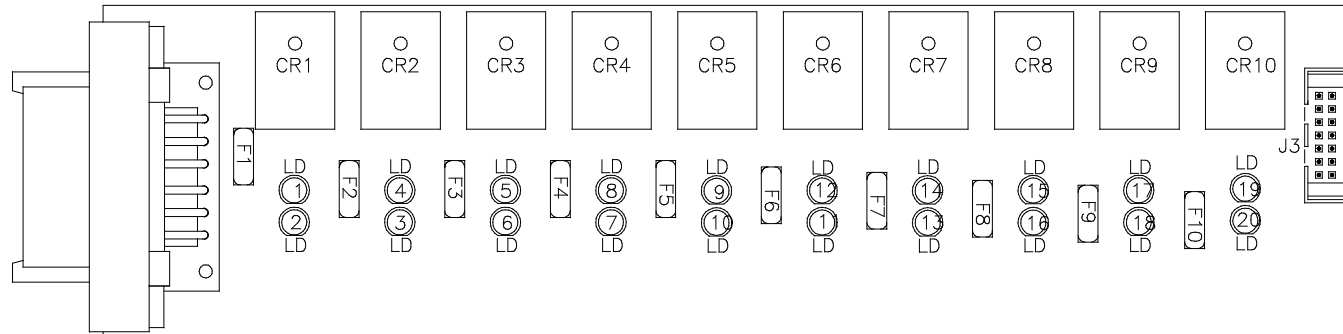

REAR AIR
OUTPUT
LED LAYOUT

LED #	COLOR	INPUT J3	FUSE #	OUTPUT	RELAY #	DESCRIPTION
LED1	YELLOW	PIN 13	---	---	CR1	TAG LIFT (COIL)
LED2	RED	---	FUSE 1	PIN 1	CR1	TAG LIFT (CONTACT)
LED3	RED	---	FUSE 2	PIN 2	CR2	LEFT REAR RAISE (CONTACT)
LED4	YELLOW	PIN 12	---	---	CR2	LEFT REAR RAISE (COIL)
LED5	YELLOW	PIN 11	---	---	CR3	LEFT REAR LOWER (COIL)
LED6	RED	---	FUSE 3	PIN 3	CR3	LEFT REAR LOWER (CONTACT)
LED7	RED	---	FUSE 4	PIN 4	CR4	RIGHT REAR RAISE (CONTACT)
LED8	YELLOW	PIN 10	---	---	CR4	RIGHT REAR RAISE (COIL)
LED9	YELLOW	PIN 9	---	---	CR5	RIGHT REAR LOWER (COIL)
LED10	RED	---	FUSE 5	PIN 5	CR5	RIGHT REAR LOWER (CONTACT)
LED11	RED	---	FUSE 6	PIN 6	CR6	NOT USED
LED12	YELLOW	PIN 8	---	---	CR6	NOT USED
LED13	RED	---	FUSE 7	PIN 10	CR7	TAG LEFT REAR LOWER (CONTACT)
LED14	YELLOW	PIN 7	---	---	CR7	TAG LEFT REAR LOWER (COIL)
LED15	YELLOW	PIN 6	---	---	CR8	TAG RIGHT REAR LOWER (COIL)
LED16	RED	---	FUSE 8	PIN 9	CR8	TAG RIGHT REAR LOWER (CONTACT)
LED17	YELLOW	PIN 5	---	---	CR9	TAG TRAVEL (COIL)
LED18	RED	---	FUSE 9	PIN 7	CR9	TAG TRAVEL (CONTACT)
LED19	YELLOW	PIN 4	---	---	CR10	TRAVEL (COIL)
LED20	RED	---	FUSE 10	PIN 8	CR10	TRAVEL (CONTACT)

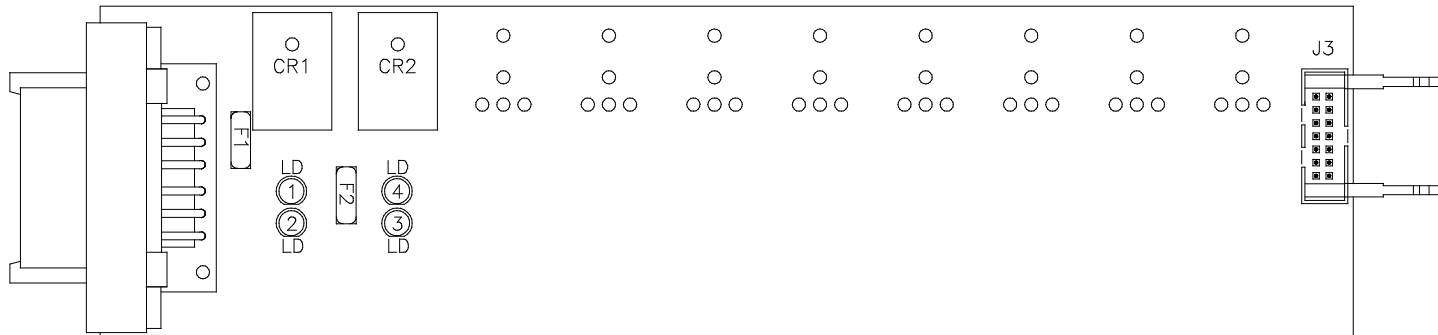

ROOM 2
LED LAYOUT

LED #	COLOR	INPUT J3	FUSE #	OUTPUT	RELAY #	DESCRIPTION
LED1	YELLOW	PIN 13	---	---	CR1	AIR SEAL (COIL)
LED2	RED	---	FUSE 1	PIN 1	CR1	AIR SEAL (CONTACT)
LED3	RED	---	FUSE 2	PIN 2	CR2	VACUUM (CONTACT)
LED4	YELLOW	PIN 12	---	---	CR2	VACUUM (COIL)
LED5	---	---	---	---	---	---
LED6	---	---	---	---	---	---
LED7	---	---	---	---	---	---
LED8	---	---	---	---	---	---
LED9	---	---	---	---	---	---
LED10	---	---	---	---	---	---
LED11	---	---	---	---	---	---
LED12	---	---	---	---	---	---
LED13	---	---	---	---	---	---
LED14	---	---	---	---	---	---
LED15	---	---	---	---	---	---
LED16	---	---	---	---	---	---
LED17	---	---	---	---	---	---
LED18	---	---	---	---	---	---
LED19	---	---	---	---	---	---
LED20	---	---	---	---	---	---