

AP27222
CENTRAL CONTROL/ROOM 1 MODULE

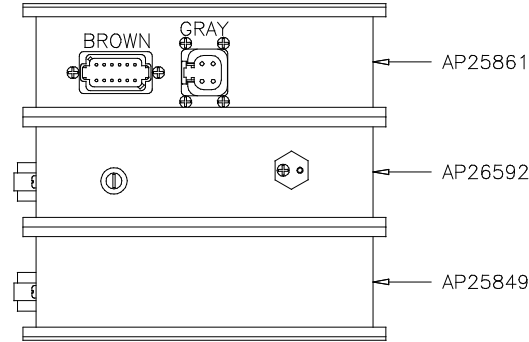
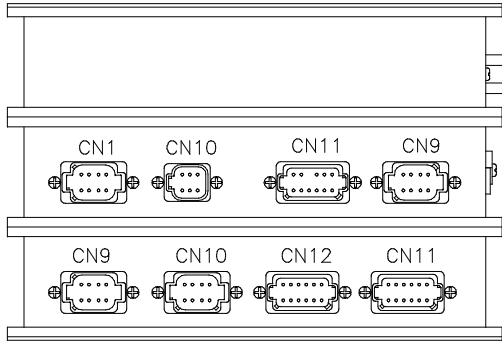

- AP25861 (BROWN)
PIN
- 1 BLK(W5050) CYLINDER EXTEND 1
 - 2 BLK(W5150) CYLINDER RETRACT 1
 - 3 N/C
 - 4 N/C
 - 5 N/C
 - 6 N/C
 - 7 BLK(W5600) AIR SEAL
 - 8 BLK(W5650) VACUUM
 - 9 N/C
 - 10 N/C
 - 11 WHT(W6230) GROUND
 - 12 N/C

- AP25861 (GRAY)
PIN
- 1 RED(W6801) SW BATT
 - 2 RED(W6801) SW BATT
 - 3 GRN(W6230) GND
 - 4 GRN(W6230) GND

- AP26592 CN1 (BLACK)
PIN
- 1 WHT(W7696) SYSTEM WAKE UP
 - 2 N/C
 - 3 RED(W6800) SW BATT
 - 4 GRN(W6230) GND
 - 5 CAN SHIELD
 - 6 RED(W6110) IGNITION
 - 7 GRN CAN LOW
 - 8 YEL CAN HI

- AP26592 CN10 (GRAY)
PIN
- 1 WHT(W7599) SWITCH LIGHT CONTROL
 - 2 WHT(W6100) RESET OUT
 - 3 WHT(W7550) RESET IN
 - 4 WHT(W6121) WARN LIGHT SUPPLY
 - 5 WHT(W6230) SWITCH LIGHT SUPPLY
 - 6 WHT(W7699) WARN LIGHT CONTROL

- AP26592 CN11 (GRAY)
PIN
- 1 RED(W6110) IGNITION
 - 2 N/C
 - 3 N/C
 - 4 N/C
 - 5 RED(W6120) IGNITION
 - 6 RED(W6100) HOUSE BATTERY
 - 7 GRN(W6230) GROUND
 - 8 WHT(W9961) NEUTRAL HOLD
 - 9 WHT(W9955) NEUTRAL HOLD
 - 10 N/C
 - 11 WHT(W9000) PARK BRAKE SWITCH
 - 12 RED(W6101) ENGINE BATTERY

- AP26592 CN9 (GREEN)
PIN
- 1 BLK(W8500) MASTER RELAY CNTRL
 - 2 BLK(W8100) SYSTEM PSW.
 - 3 N/C
 - 4 BLK(W8600) PMP RELAY CNTRL
 - 5 BLK(W9900) SPEED SWITCH
 - 6 BLK(W9901) SW BATT FROM PUMP RELAY
 - 7 N/C
 - 8 N/C

- AP25849 CN9 (BLACK)
PIN
- 1 WHT(W7696) SYSTEM WAKE UP
 - 2 N/C
 - 3 RED(W6800) SW BATTERY
 - 4 GRN(W6230) GROUND
 - 5 CAN SHIELD
 - 6 RED(W6110) IGNITION
 - 7 GRN CAN LOW
 - 8 YEL CAN HI

- AP25849 CN10 (GRAY)
PIN
- 1 N/C
 - 2 WHT(W7510) READY TO OPERATE
 - 3 WHT(W7530) PUMP
 - 4 WHT(W7501) EXTEND
 - 5 WHT(W7502) RETRACT
 - 6 RED(W6805) SW BATTERY
 - 7 WHT(W7631) SYSTEM WAKE UP
 - 8 GRN(W6230) GROUND

- AP25849 CN12 (GRAY)
PIN
- 1 N/C
 - 2 BLK(W5701) FRONT ROOM OUT
 - 3 N/C
 - 4 N/C
 - 5 N/C
 - 6 WHT(W6230) GROUND
 - 7 RED(W6121) SW BATTERY
 - 8 N/C
 - 9 N/C
 - 10 BLK(W5703) UPPER FRONT ROOM IN
 - 11 N/C
 - 12 N/C

- AP25849 CN 11 (GREEN)
PIN
- 1 N/C
 - 2 N/C
 - 3 N/C
 - 4 N/C
 - 5 N/C
 - 6 WHT(W6231) GROUND
 - 7 N/C
 - 8 BLK(W5651) VACUUM SENSE
 - 9 N/C
 - 10 N/C
 - 11 N/C
 - 12 N/C

			HWH I-80 EXIT 267 SOUTH RT 1 MOSCOW, IOWA 52760	
			SCALE 1:3	DATE 09NOV04
			DRAWN BY .	
△	12FEB08	WAS AP27846		
1	12FEB08	ADDED NOTE, WAS A/R		
NO.	DATE	REVISION		
THE INFORMATION DISCLOSED ON THIS DRAWING IS CONFIDENTIAL AND MUST NOT BE DISCLOSED OR USED IN ANY MANNER WHICH WILL BE DETRIMENTAL TO THE HWH CORPORATION			DRAWING NUMBER MP89370 A/P	

SYSTEM SCHEMATIC ELEC

NOTE: INSTALLATION MUST CONFORM TO GOOD SHOP PRACTICES, SAE STANDARDS, RVIA STANDARDS, AND OTHER APPLICABLE STANDARDS.

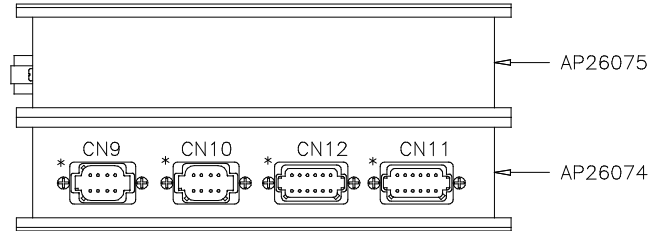
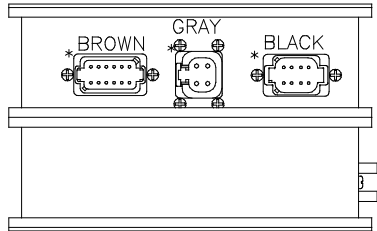

AP24299
FRONT AIR MODULE

* DESIGNATES PIN 1 OF CONNECTORS

AP26075 (BROWN)

- PIN
- 1 N/C
 - 2 BLK(W1500) LEFT FRONT RAISE
 - 3 BLK(W1600) LEFT FRONT LOWER
 - 4 BLK(W2500) RIGHT FRONT RAISE
 - 5 BLK(W2600) RIGHT FRONT LOWER
 - 6 BLK(W9700) COMPRESSOR
 - 7 N/C
 - 8 BLK(W1700) TRAVEL
 - 9 N/C
 - 10 N/C
 - 11 WHT(W6254) GROUND
 - 12 N/C

AP26075 (GRAY)

- PIN
- 1 RED(W6800) SW BATT
 - 2 RED(W6800) SW BATT
 - 3 GRN(W6230) GND
 - 4 GRN(W6230) GND

AP26075 (BLACK)

- PIN
- 1 N/C
 - 2 N/C
 - 3 RED(W6800) SW BATTERY
 - 4 GRN(W6230) GROUND
 - 5 CAN SHIELD
 - 6 N/C
 - 7 GRN CAN LOW
 - 8 YEL CAN HI

AP26074 CN9(BLACK)

- PIN
- 1 WHT(W7696) SYSTEM WAKE UP
 - 2 N/C
 - 3 RED(W6800) SW BATTERY
 - 4 GRN(W6230) GROUND
 - 5 CAN SHIELD
 - 6 RED(W6110) IGNITION
 - 7 GRN CAN LOW
 - 8 YEL CAN HI

AP26074 CN10(GRAY)

- PIN
- 1 N/C
 - 2 N/C
 - 3 N/C
 - 4 N/C
 - 5 N/C
 - 6 N/C
 - 7 N/C
 - 8 N/C

AP26074 CN12(GRAY)

- PIN
- 1 N/C
 - 2 N/C
 - 3 N/C
 - 4 N/C
 - 5 N/C
 - 6 WHT(W6236) GROUND
 - 7 BLK(W6800) SW. BATT
 - 8 N/C
 - 9 N/C
 - 10 BLK(W2210) RIGHT FRONT PSW
 - 11 BLK(W7521) TAG DUMP SW.
 - 12 N/C

AP26074 CN11(GREEN)

- PIN
- 1 N/C
 - 2 N/C
 - 3 N/C
 - 4 N/C
 - 5 N/C
 - 6 WHT(W6235) GROUND
 - 7 N/C
 - 8 N/C
 - 9 N/C
 - 10 BLK(W1210) LEFT FRONT PSW
 - 11 N/C
 - 12 N/C

AP27577
REAR AIR MODULE

AP26108 (BLACK)

PIN	DESCRIPTION
1	BLK(W3800) TAG DUMP
2	BLK(W4500) LEFT REAR RAISE
3	BLK(W4600) LEFT REAR LOWER
4	BLK(W3500) RIGHT REAR RAISE
5	BLK(W3600) RIGHT REAR LOWER
6	N/C
7	BLK(W3701) TAG TRAVEL
8	BLK(W3700) TRAVEL
9	BLK(W3601) TAG RIGHT LOWER
10	BLK(W4601) TAG LEFT LOWER
11	WHT(W6258) GROUND
12	N/C

AP26108 (GRAY)

PIN	DESCRIPTION
1	RED(W6800) SW BATT
2	RED(W6800) SW BATT
3	GRN(W6230) GND
4	GRN(W6230) GND

AP25916 CN9 (BLACK)

PIN	DESCRIPTION
1	WHT(W7696) SYSTEM WAKE UP
2	N/C
3	RED(W6800) SW BATTERY
4	GRN(W6230) GROUND
5	CAN SHIELD
6	RED(W6110) IGNITION
7	GRN CAN LOW
8	YEL CAN HI

AP25916 CN10 (GRAY)

PIN	DESCRIPTION
1	N/C
2	N/C
3	N/C
4	N/C
5	N/C
6	N/C

AP25916 CN12 (GRAY)

PIN	DESCRIPTION
1	BLK(W4211) TAG LEFT PRESS SW.
2	BLK(W3211) TAG RIGHT PRESS SW
3	BLK(W3215) SYSTEM PRESS SW.
4	N/C
5	N/C
6	WHT(W6231) GROUND
7	N/C
8	N/C
9	N/C
10	N/C
11	N/C
12	N/C

AP25916 CN11 (GREEN)

PIN	DESCRIPTION
1	N/C
2	BLK(W4210) LEFT REAR PRESS. SW.
3	BLK(W3210) RIGHT REAR PRESS. SW.
4	N/C
5	N/C
6	WHT(W6232) GROUND
7	N/C
8	N/C
9	N/C
10	N/C
11	N/C
12	N/C

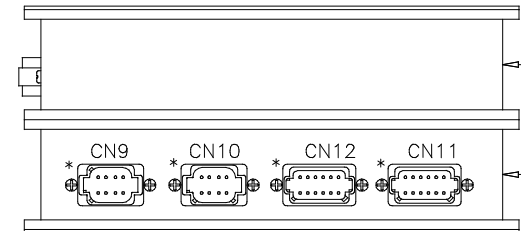
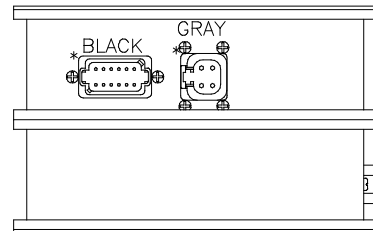

AP26108

AP25916

* DESIGNATES PIN 1 OF CONNECTORS

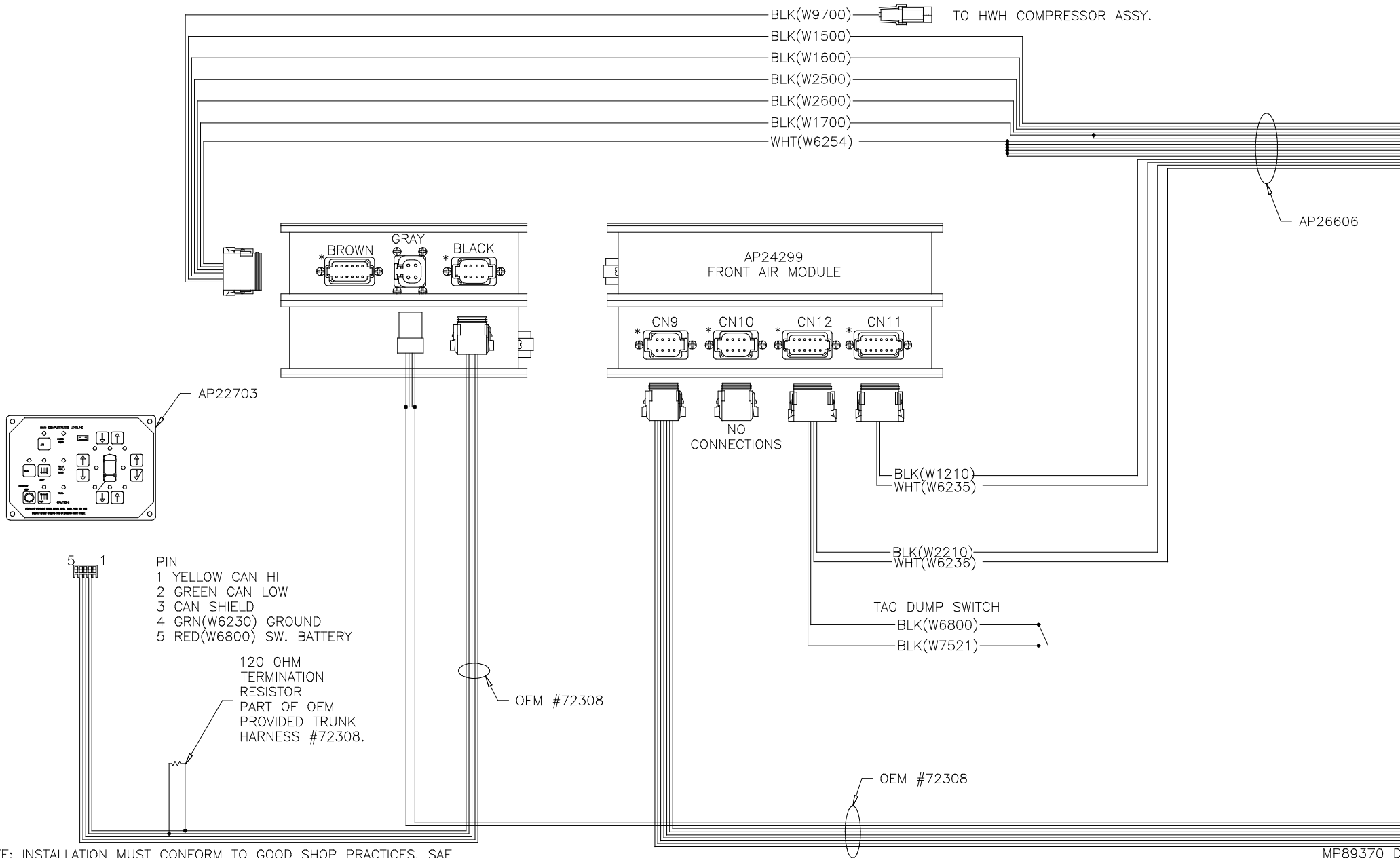

NOTE: INSTALLATION MUST CONFORM TO GOOD SHOP PRACTICES, SAE STANDARDS, RVIA STANDARDS, AND OTHER APPLICABLE STANDARDS.

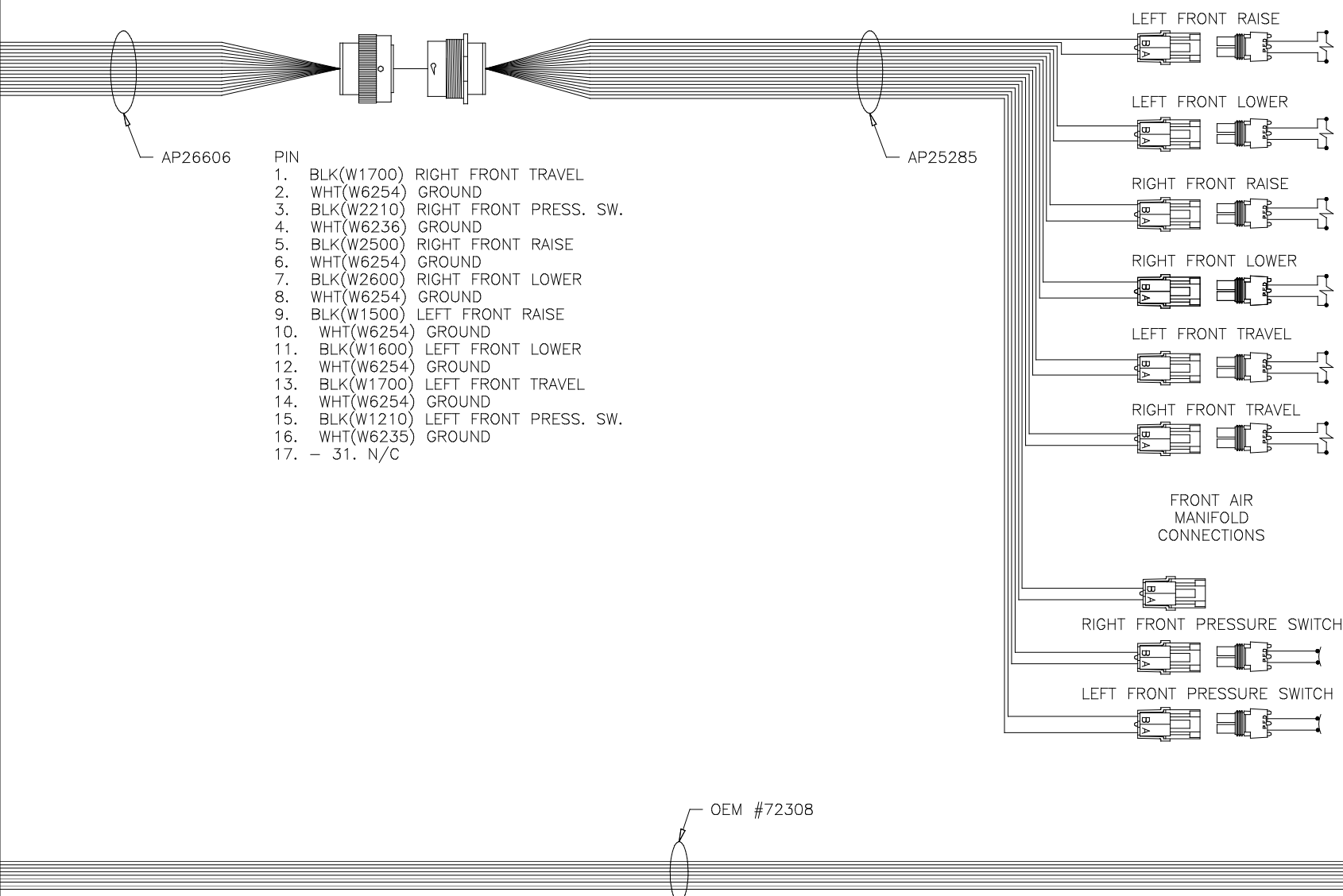

NOTE: INSTALLATION MUST CONFORM TO GOOD SHOP PRACTICES, SAE STANDARDS, RVIA STANDARDS, AND OTHER APPLICABLE STANDARDS.

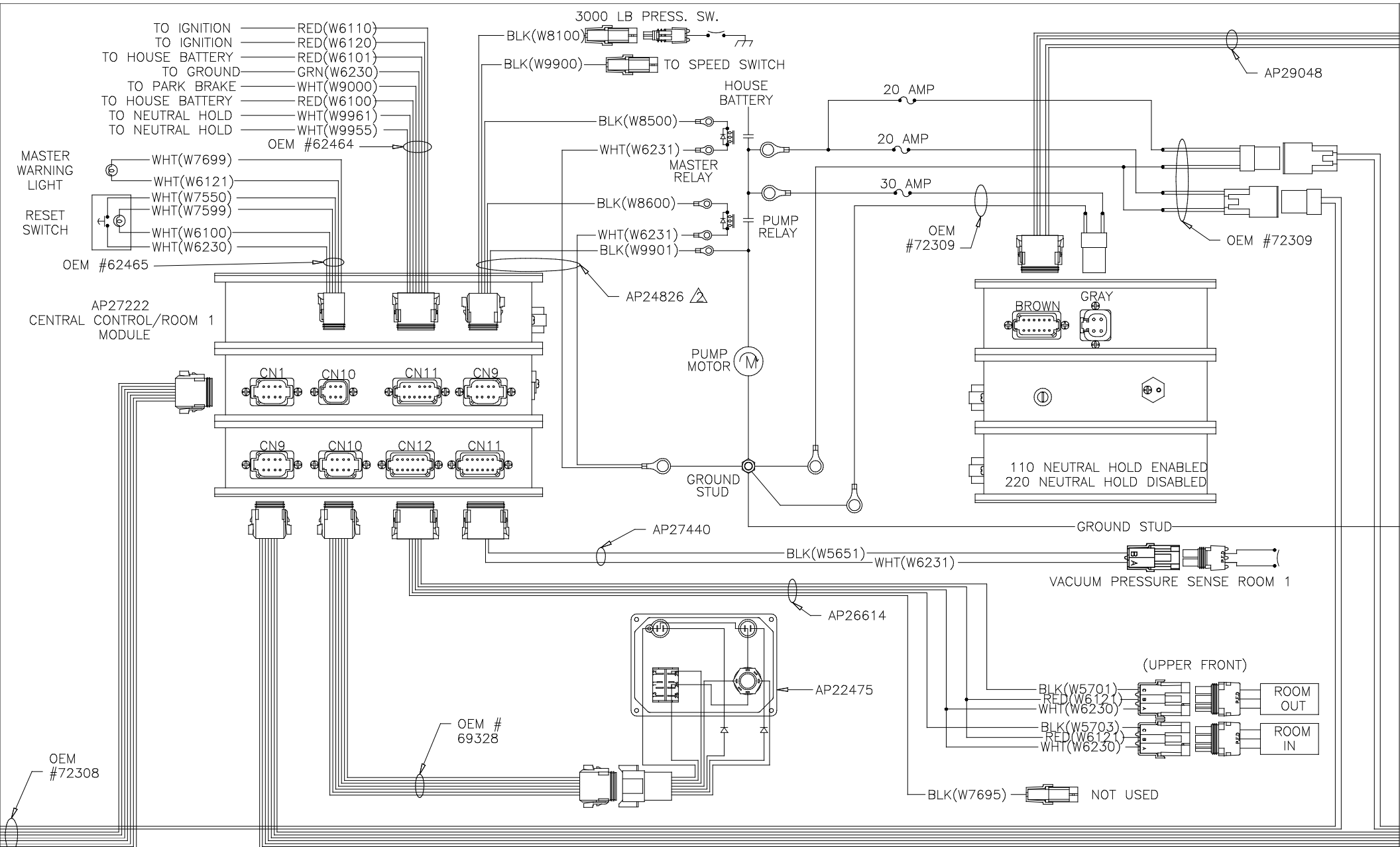

NOTE: INSTALLATION MUST CONFORM TO GOOD SHOP PRACTICES, SAE STANDARDS, RVIA STANDARDS, AND OTHER APPLICABLE STANDARDS.

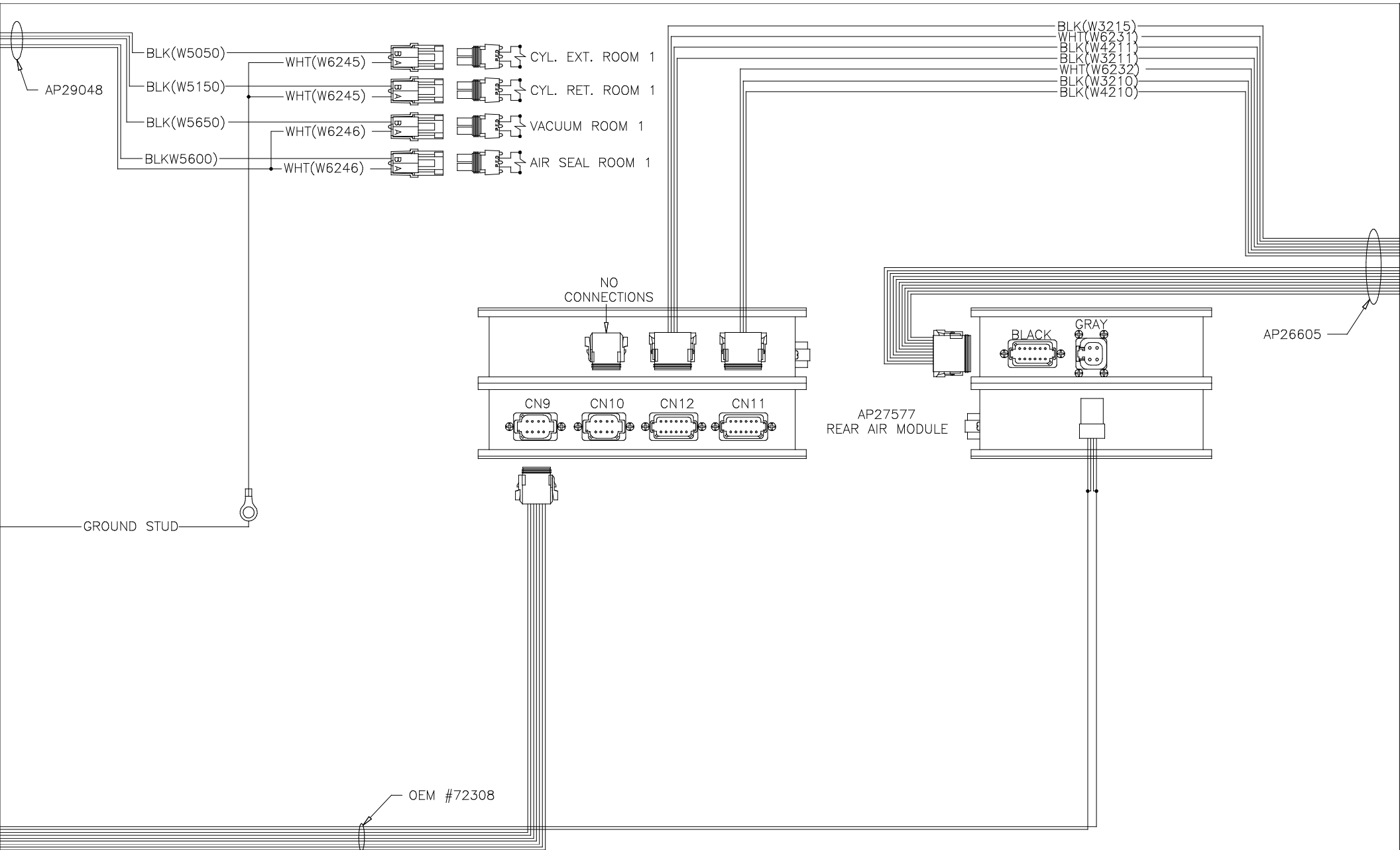

NOTE: INSTALLATION MUST CONFORM TO GOOD SHOP PRACTICES, SAE STANDARDS, RVIA STANDARDS, AND OTHER APPLICABLE STANDARDS.

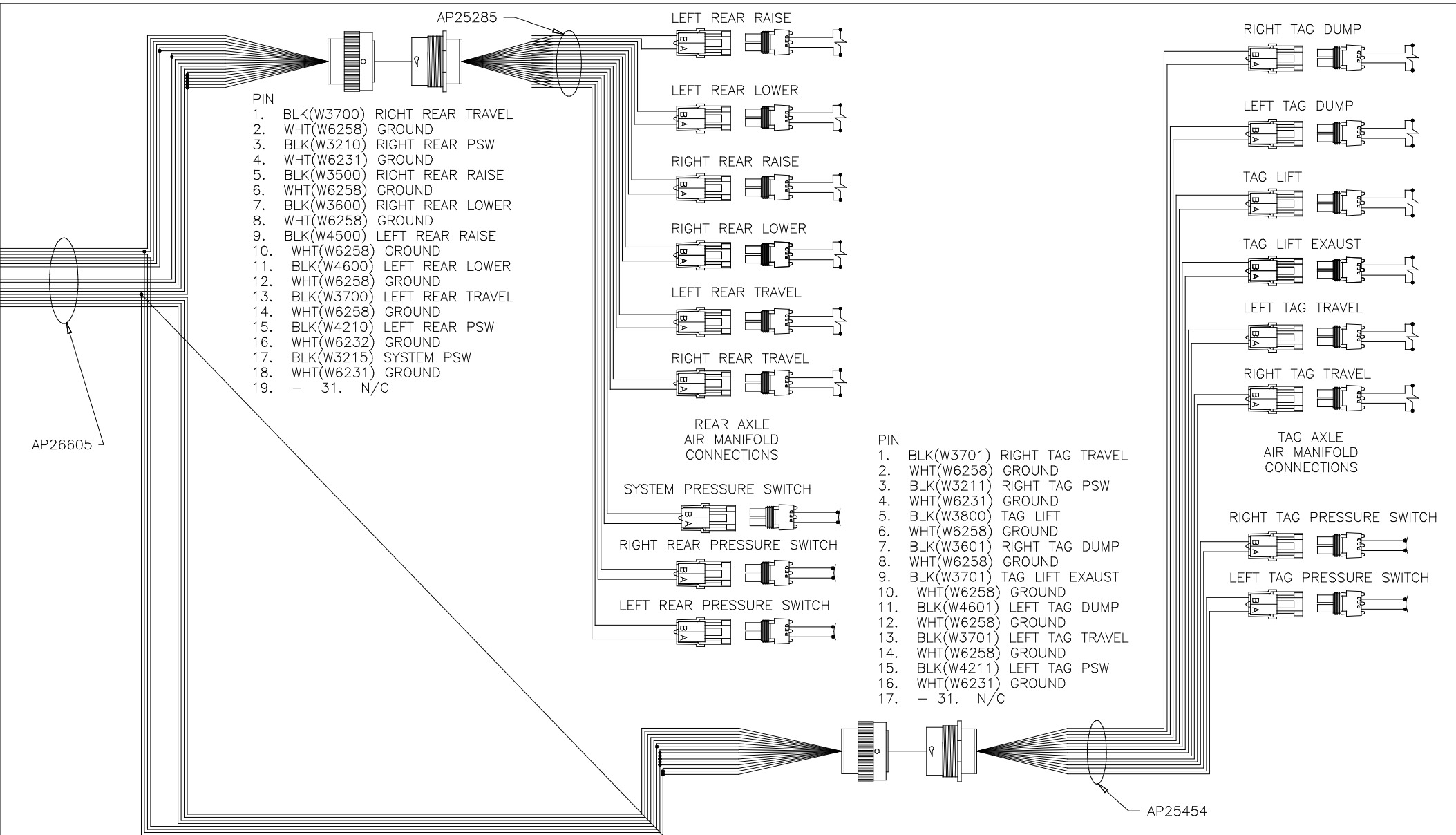

NOTE: INSTALLATION MUST CONFORM TO GOOD SHOP PRACTICES, SAE STANDARDS, RVIA STANDARDS, AND OTHER APPLICABLE STANDARDS.

FRONT AIR
MODULE
LED LAYOUT

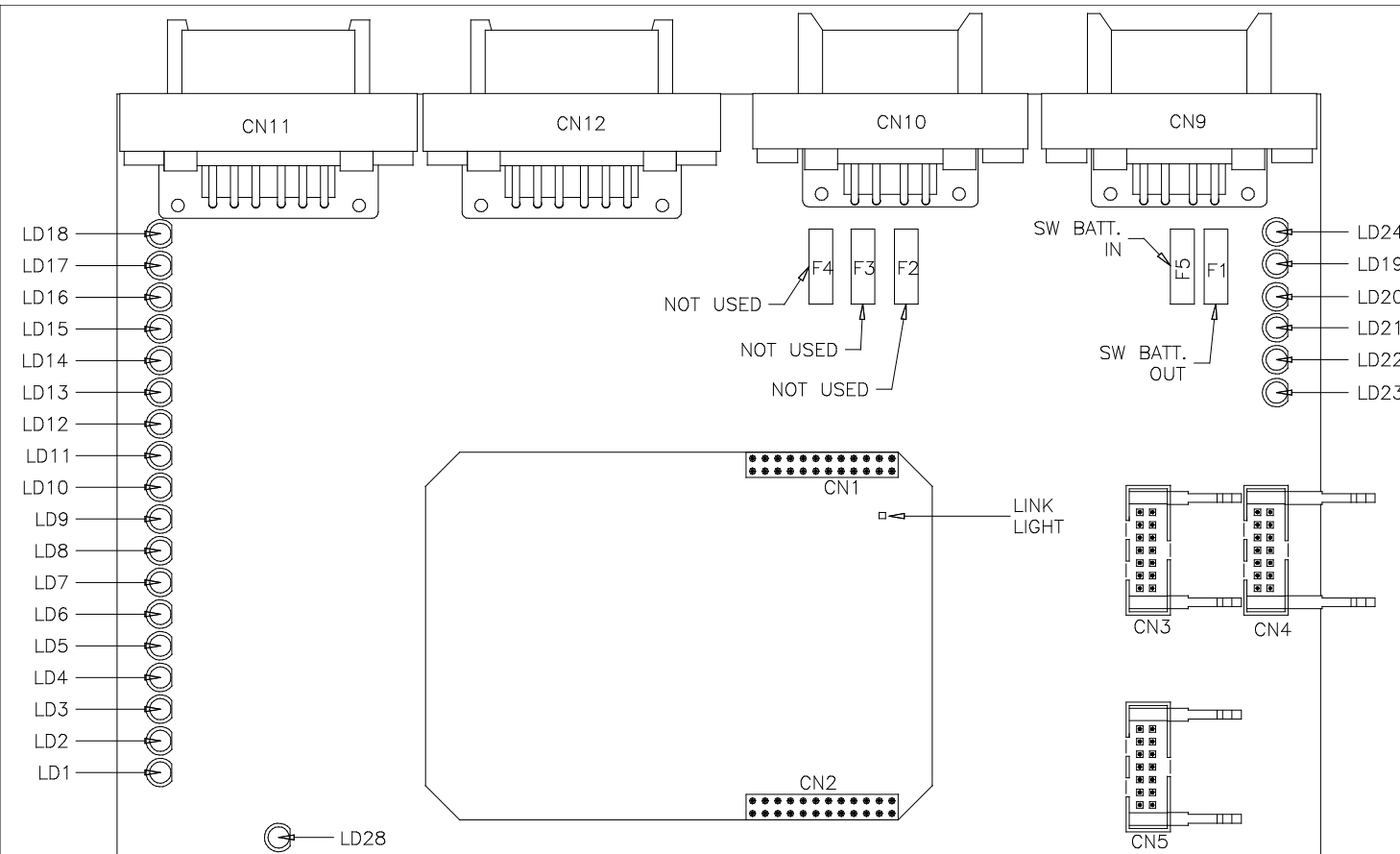

LED #	CONNECTOR	COLOR	DESCRIPTION	LED #	CONNECTOR	COLOR	DESCRIPTION
LED 1	NOT USED	RED	NOT USED	LED 11	NOT USED	YELLOW	NOT USED
LED 2	NOT USED	RED	NOT USED	LED 12	NOT USED	YELLOW	NOT USED
LED 3	NOT USED	GREEN	NOT USED	LED 13	NOT USED	YELLOW	NOT USED
LED 4	NOT USED	YELLOW	NOT USED	LED 14	NOT USED	YELLOW	NOT USED
LED 5	NOT USED	YELLOW	NOT USED	LED 15	NOT USED	GREEN	NOT USED
LED 6	NOT USED	YELLOW	NOT USED	LED 16	NOT USED	GREEN	NOT USED
LED 7	NOT USED	GREEN	NOT USED	LED 17	NOT USED	GREEN	NOT USED
LED 8	NOT USED	GREEN	NOT USED	LED 18	NOT USED	GREEN	NOT USED
LED 9	CN11 PIN 10	GREEN	LEFT FRONT PSW	LED 19	CN11/CN12 PIN 7	RED	12V OUTPUT
LED 10	CN12 PIN 10	GREEN	RIGHT FRONT PSW	LED 20	NOT USED	RED	NOT USED
				LED 21	NOT USED	RED	NOT USED
				LED 22	NOT USED	RED	NOT USED
				LED 23	NOT USED	RED	NOT USED
				LED 24	NOT USED	RED	NOT USED
				LED 28	CN12 PIN 11	RED	TAG DUMP PB

NOTE: INSTALLATION MUST CONFORM TO GOOD SHOP PRACTICES, SAE STANDARDS, RVIA STANDARDS, AND OTHER APPLICABLE STANDARDS.

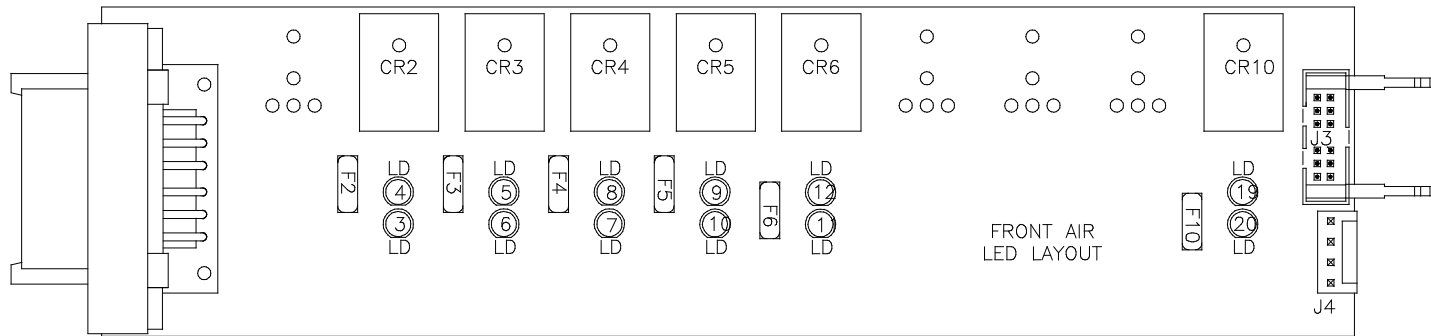

LED #	COLOR	INPUT J3	FUSE #	OUTPUT	RELAY #	DESCRIPTION
LED3	RED	---	FUSE 2	PIN 2	CR2	LEFT FRONT RAISE (CONTACT)
LED4	YELLOW	PIN 12	---	---	CR2	LEFT FRONT RAISE (COIL)
LED5	YELLOW	PIN 11	---	---	CR3	LEFT FRONT LOWER (COIL)
LED6	RED	---	FUSE 3	PIN 3	CR3	LEFT FRONT LOWER (CONTACT)
LED7	RED	---	FUSE 4	PIN 4	CR4	RIGHT FRONT RAISE (CONTACT)
LED8	YELLOW	PIN 10	---	---	CR4	RIGHT FRONT RAISE (COIL)
LED9	YELLOW	PIN 9	---	---	CR5	RIGHT FRONT LOWER (COIL)
LED10	RED	---	FUSE 5	PIN 5	CR5	RIGHT FRONT LOWER (CONTACT)
LED11	RED	---	FUSE 6	PIN 6	CR6	COMPRESSOR (CONTACT)
LED12	YELLOW	PIN 8	---	---	CR6	COMPRESSOR (COIL)
LED19	YELLOW	PIN 4	---	---	CR10	TRAVEL (COIL)
LED20	RED	---	FUSE 10	PIN 8	CR10	TRAVEL (CONTACT)

NOTE: INSTALLATION MUST CONFORM TO GOOD SHOP PRACTICES, SAE STANDARDS, RVIA STANDARDS, AND OTHER APPLICABLE STANDARDS.

MP89370 J
12FEB08

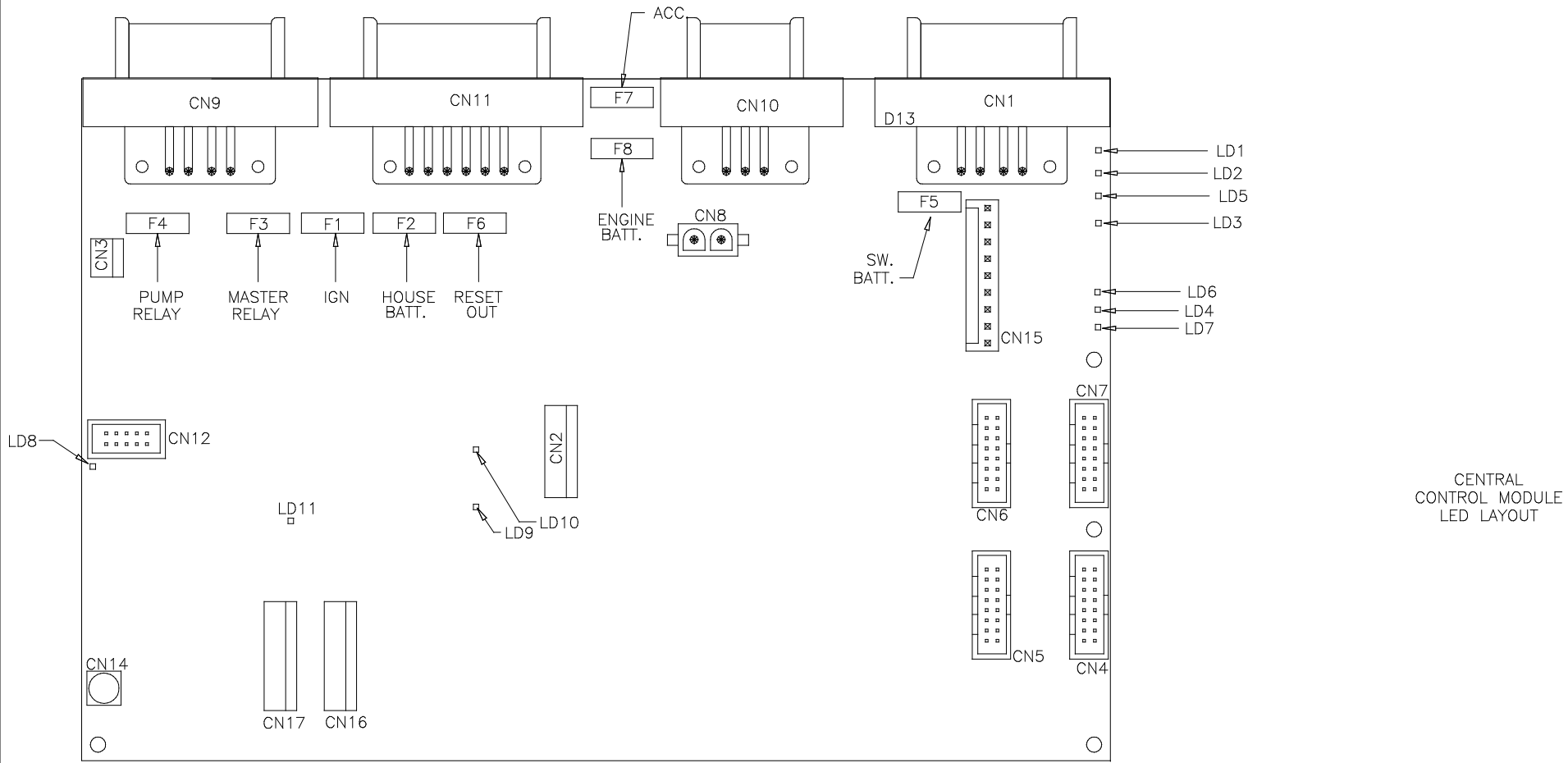

CENTRAL CONTROL MODULE LED LAYOUT

LED #	CONNECTOR	COLOR	DESCRIPTION
LED 1	CN 9 PIN 1	RED	MASTER RELAY
LED 2	CN 9 PIN 4	RED	PUMP RELAY
LED 3	CN 1 PIN 3	RED	SW 12V
LED 4	CN 11 PIN 12	RED	ENGINE BATT
LED 5	CN 9 PIN 5	RED	SPEED SWITCH
LED 6	NOT USED	NOT USED	NOT USED

LED #	CONNECTOR	COLOR	DESCRIPTION
LED 7	CN 1 PIN 7 & 8	RED	LINK LIGHT
LED 8	CN 11 PIN 8 & 9	RED	NEUTRAL HOLD
LED 9	NOT USED	NOT USED	NOT USED
LED 10	CN9 PIN 2	RED	3000 LBS. PSW
LED 11	CN11 PIN 11	RED	PARK BRAKE

NOTE: INSTALLATION MUST CONFORM TO GOOD SHOP PRACTICES, SAE STANDARDS, RVIA STANDARDS, AND OTHER APPLICABLE STANDARDS.

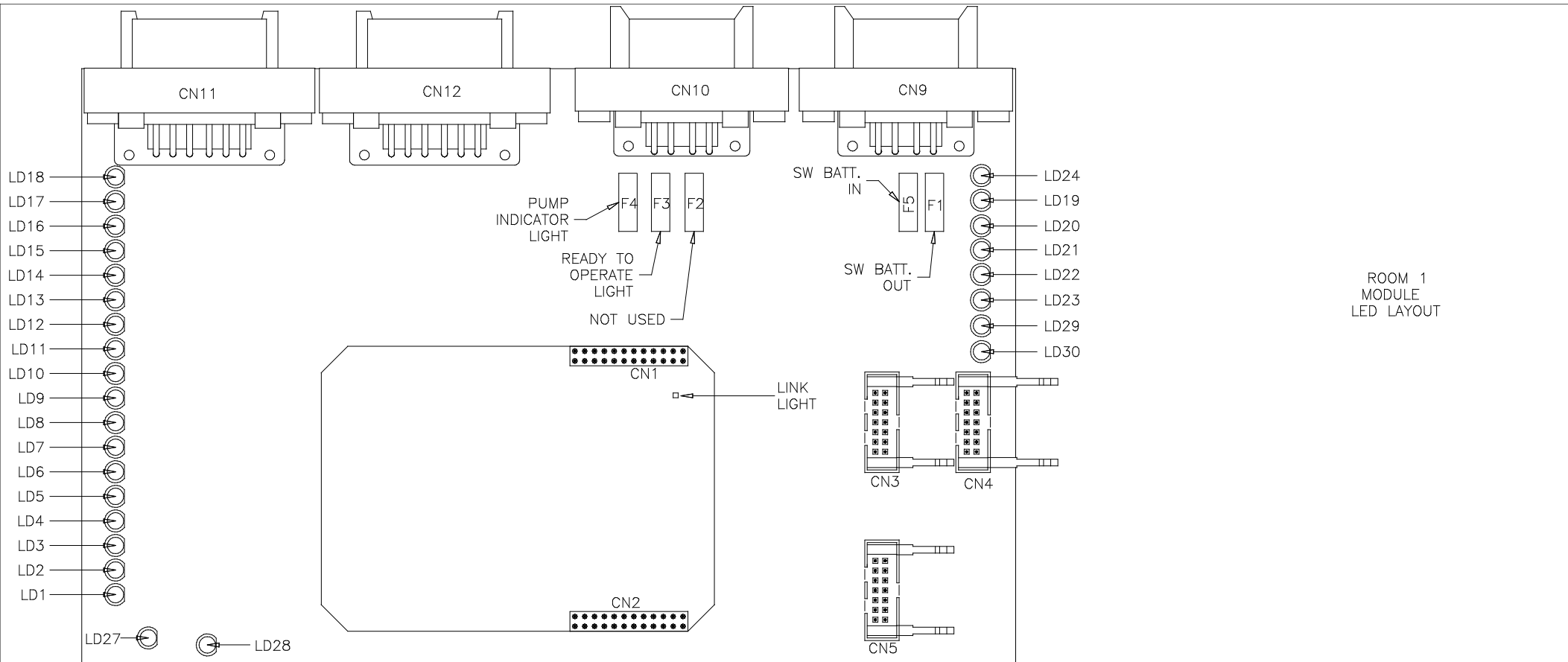

ROOM 1
MODULE
LED LAYOUT

LED #	CONNECTOR	COLOR	DESCRIPTION
LED 1	CN10 PIN 4	RED	EXTEND
LED 2	CN10 PIN 5	RED	RETRACT
LED 3	NOT USED	GREEN	NOT USED
LED 4	NOT USED	YELLOW	NOT USED
LED 5	NOT USED	YELLOW	NOT USED
LED 6	CN12 PIN 2	YELLOW	FRONT ROOM OUT
LED 7	NOT USED	GREEN	NOT USED
LED 8	NOT USED	GREEN	NOT USED
LED 9	NOT USED	GREEN	NOT USED
LED 10	CN12 PIN 10	GREEN	UPPER FRONT ROOM IN
LED 11	NOT USED	YELLOW	NOT USED
LED 12	NOT USED	YELLOW	NOT USED
LED 13	NOT USED	YELLOW	NOT USED

LED #	CONNECTOR	COLOR	DESCRIPTION
LED 14	NOT USED	YELLOW	NOT USED
LED 15	NOT USED	GREEN	NOT USED
LED 16	NOT USED	GREEN	NOT USED
LED 17	NOT USED	GREEN	NOT USED
LED 18	NOT USED	GREEN	NOT USED
LED 19	CN11/CN12 PIN 7	RED	12V OUTPUT
LED 20	CN9 PIN 3	RED	SW BATT
LED 21	CN10 PIN 3	RED	PUMP INDICATOR
LED 22	CN10 PIN 2	RED	READY TO OPERATE
LED 23	NOT USED	RED	NOT USED
LED 24	CN10 PIN 7	RED	SYSTEM WAKE UP
LED 27	CN11 PIN 8	RED	VACUUM SENSE
LED 28	NOT USED	RED	NOT USED
LED 29	CN6 PIN 1	RED	AIR SEAL OUTPUT
LED 30	NOT USED	RED	NOT USED

NOTE: INSTALLATION MUST CONFORM TO GOOD SHOP PRACTICES, SAE STANDARDS, RVIA STANDARDS, AND OTHER APPLICABLE STANDARDS.

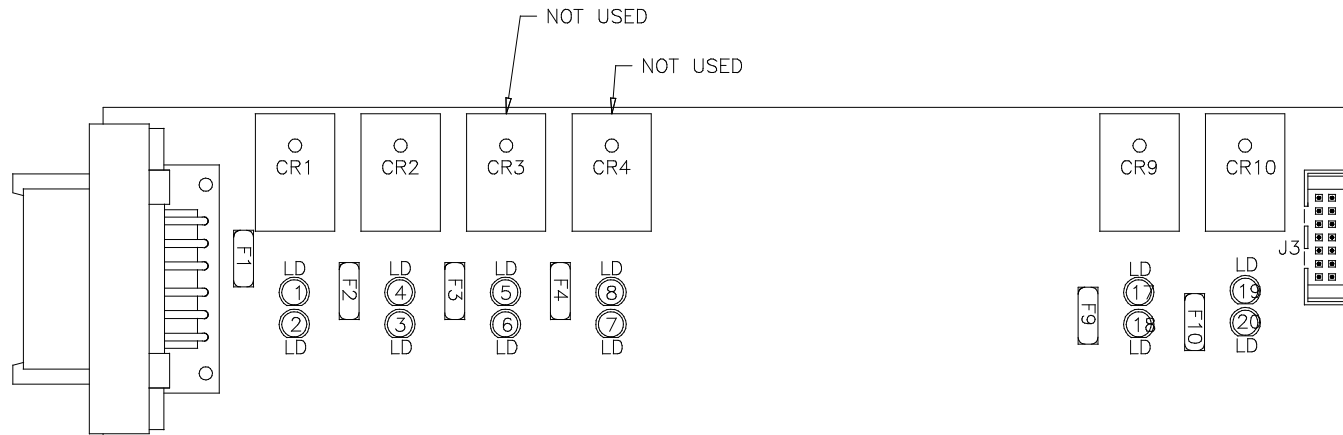

ROOM 1
LED LAYOUT

LED #	COLOR	INPUT J3	FUSE #	OUTPUT	RELAY #	DESCRIPTION
LED1	YELLOW	PIN 13	---	---	CR1	CYL EXTEND 1 (COIL)
LED2	RED	---	FUSE 1	PIN 1	CR1	CYL EXTEND 1 (CONTACT)
LED3	RED	---	FUSE 2	PIN 2	CR2	CYL RETRACT 1 (CONTACT)
LED4	YELLOW	PIN 12	---	---	CR2	CYL RETRACT RM 1 (COIL)
LED17	YELLOW	PIN 5	---	---	CR9	AIR SEAL (COIL)
LED18	RED	---	FUSE 9	PIN 7	CR9	AIR SEAL (CONTACT)
LED19	YELLOW	PIN 4	---	---	CR10	VACUUM (COIL)
LED20	RED	---	FUSE 10	PIN 8	CR10	VACUUM (CONTACT)

NOTE: INSTALLATION MUST CONFORM TO GOOD SHOP PRACTICES, SAE STANDARDS, RVIA STANDARDS, AND OTHER APPLICABLE STANDARDS.

MP89370 M
12FEB08

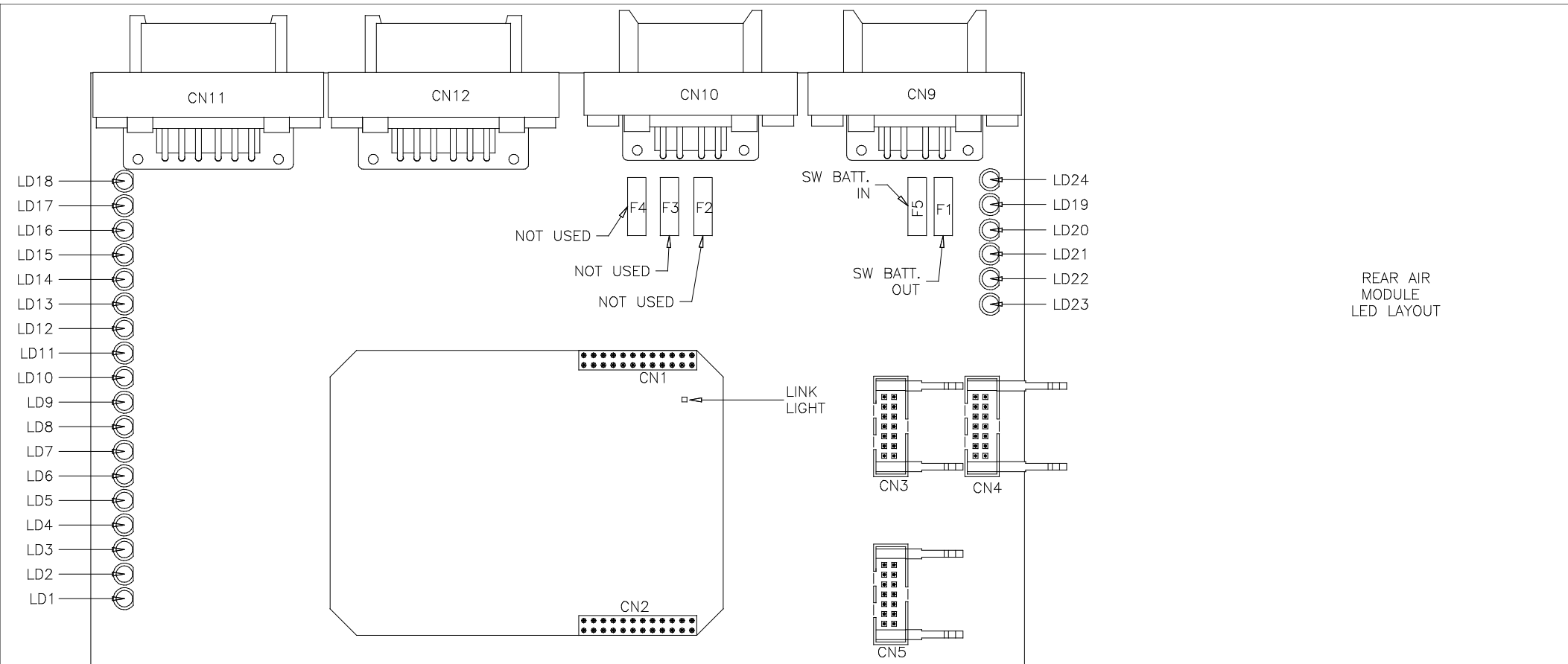

REAR AIR
MODULE
LED LAYOUT

LED #	CONNECTOR	COLOR	DESCRIPTION	LED #	CONNECTOR	COLOR	DESCRIPTION
LED 1	NOT USED	RED	NOT USED	LED 10	NOT USED	GREEN	NOT USED
LED 2	NOT USED	RED	NOT USED	LED 11	NOT USED	YELLOW	NOT USED
LED 3	NOT USED	GREEN	NOT USED	LED 12	CN12 PIN 1	YELLOW	LEFT TAG PRESS. SW
LED 4	NOT USED	YELLOW	NOT USED	LED 13	NOT USED	YELLOW	NOT USED
LED 5	CN11 PIN 2	YELLOW	LEFT REAR PRESS. SW.	LED 14	NOT USED	YELLOW	NOT USED
LED 6	CN12 PIN 2	YELLOW	RIGHT TAG PRESS. SW.	LED 15	NOT USED	GREEN	NOT USED
LED 7	CN11 PIN 3	GREEN	RIGHT REAR PRESS. SW.	LED 16	NOT USED	GREEN	NOT USED
LED 8	CN12 PIN 3	GREEN	SYSTEM PRESS SW.	LED 17	NOT USED	GREEN	NOT USED
LED 9	NOT USED	GREEN	NOT USED	LED 18	NOT USED	GREEN	NOT USED
				LED 19	CN11/CN12 PIN 7	RED	12V OUT
				LED 20	NOT USED	RED	NOT USED
				LED 21	NOT USED	RED	NOT USED
				LED 22	NOT USED	RED	NOT USED
				LED 23	NOT USED	RED	NOT USED
				LED 24	NOT USED	RED	NOT USED

NOTE: INSTALLATION MUST CONFORM TO GOOD SHOP PRACTICES, SAE STANDARDS, RVIA STANDARDS, AND OTHER APPLICABLE STANDARDS.

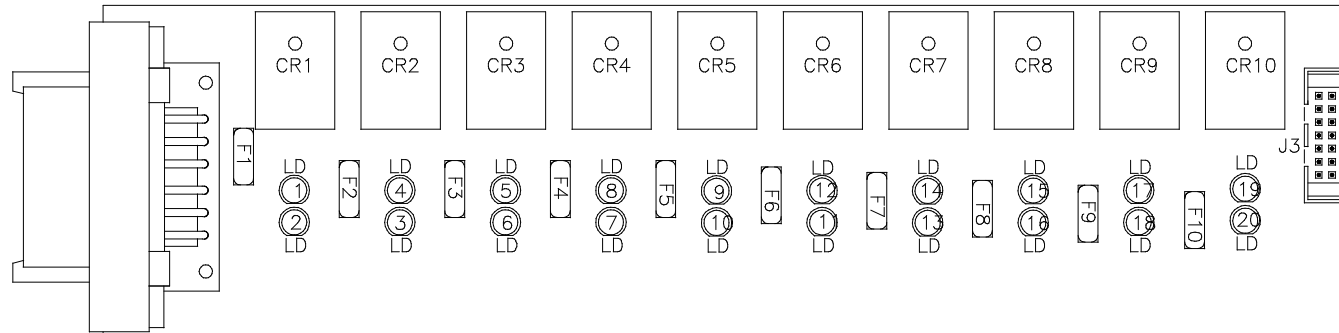

REAR AIR
LED LAYOUT

LED #	COLOR	INPUT J3	FUSE #	OUTPUT	RELAY #	DESCRIPTION
LED1	YELLOW	PIN 13	---	---	CR1	TAG LIFT (COIL)
LED2	RED	---	FUSE 1	PIN 1	CR1	TAG LIFT (CONTACT)
LED3	RED	---	FUSE 2	PIN 2	CR2	LEFT REAR RAISE (CONTACT)
LED4	YELLOW	PIN 12	---	---	CR2	LEFT REAR RAISE (COIL)
LED5	YELLOW	PIN 11	---	---	CR3	LEFT REAR LOWER (COIL)
LED6	RED	---	FUSE 3	PIN 3	CR3	LEFT REAR LOWER (CONTACT)
LED7	RED	---	FUSE 4	PIN 4	CR4	RIGHT REAR RAISE (CONTACT)
LED8	YELLOW	PIN 10	---	---	CR4	RIGHT REAR RAISE (COIL)
LED9	YELLOW	PIN 9	---	---	CR5	RIGHT REAR LOWER (COIL)
LED10	RED	---	FUSE 5	PIN 5	CR5	RIGHT REAR LOWER (CONTACT)
LED11	RED	---	FUSE 6	PIN 6	CR6	NOT USED
LED12	YELLOW	PIN 8	---	---	CR6	NOT USED
LED13	RED	---	FUSE 7	PIN 10	CR7	TAG LEFT REAR LOWER (CONTACT)
LED14	YELLOW	PIN 7	---	---	CR7	TAG LEFT REAR LOWER (COIL)
LED15	YELLOW	PIN 6	---	---	CR8	TAG RIGHT REAR LOWER (COIL)
LED16	RED	---	FUSE 8	PIN 9	CR8	TAG RIGHT REAR LOWER (CONTACT)
LED17	YELLOW	PIN 5	---	---	CR9	TAG TRAVEL (COIL)
LED18	RED	---	FUSE 9	PIN 7	CR9	TAG TRAVEL (CONTACT)
LED19	YELLOW	PIN 4	---	---	CR10	TRAVEL (COIL)
LED20	RED	---	FUSE 10	PIN 8	CR10	TRAVEL (CONTACT)

NOTE: INSTALLATION MUST CONFORM TO GOOD SHOP PRACTICES, SAE STANDARDS, RVIA STANDARDS, AND OTHER APPLICABLE STANDARDS.

MP89370 0
12FEB08

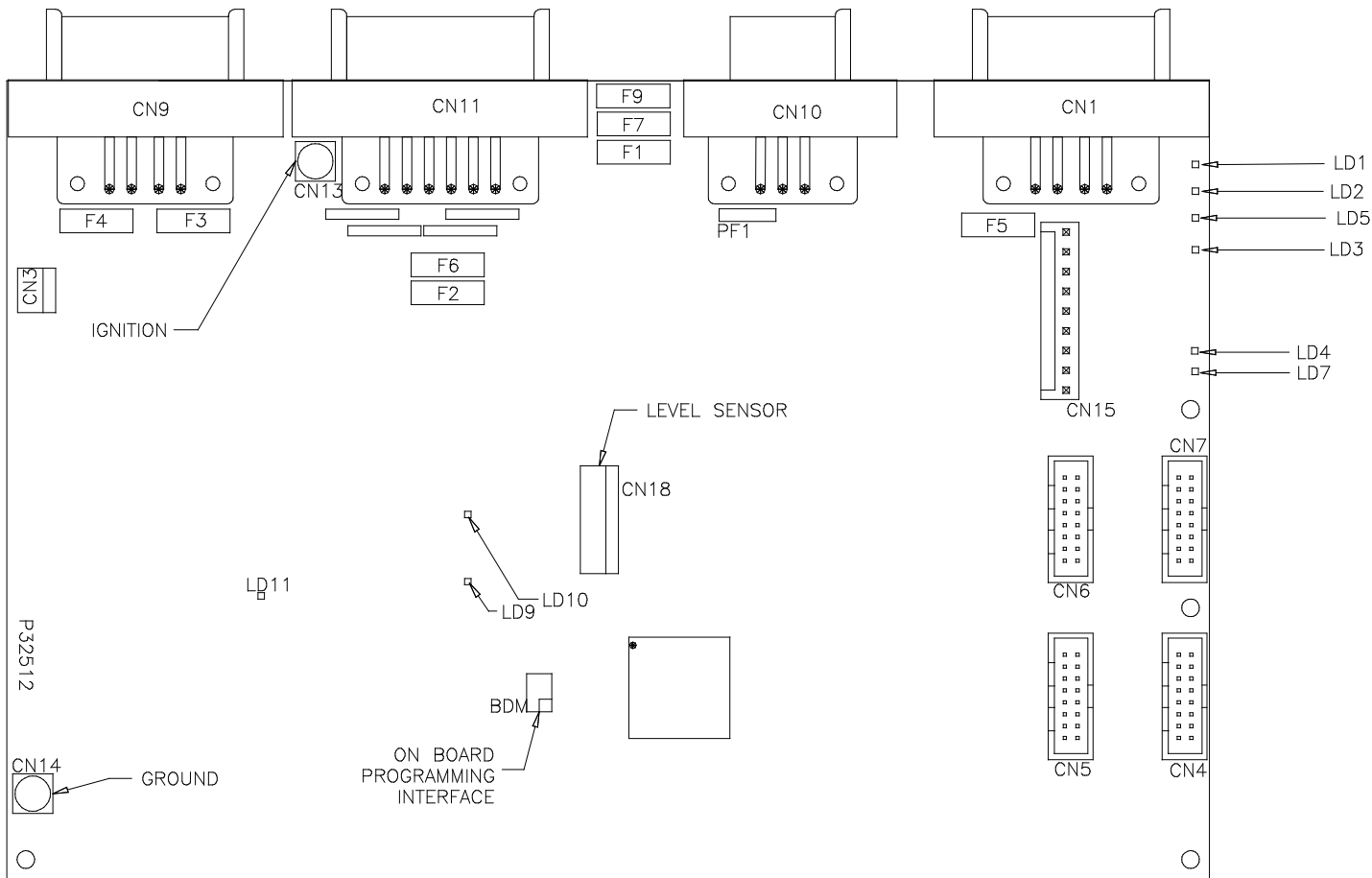

CENTRAL
CONTROL MODULE
LED LAYOUT
EFFECTIVE APPROXIMATELY
SEPTEMBER, 2005

LED #	CONNECTOR	COLOR	DESCRIPTION
LED 1	CN 9 PIN 1	RED	MASTER RELAY
LED 2	CN 9 PIN 4	RED	PUMP RELAY
LED 3	CN 1 PIN 3	RED	SW 12V
LED 4	CN 11 PIN 12	RED	ENGINE BATT
LED 5	CN 9 PIN 5	RED	SPEED SWITCH
LED 7	CN 1 PIN 7 & 8	RED	LINK LIGHT
LED 8	CN 11 PIN 8 & 9	RED	NEUTRAL HOLD
LED 9	NOT USED	RED	NOT USED
LED 10	CN9 PIN 2	RED	3000 LBS. PSW
LED 11	CN11 PIN 11	RED	PARK BRAKE

FUSE #	DESCRIPTION
PF1	RESET OUT
F7	ACCESSORY
F1	IGNITION
F2	HOUSE BATTERY
F3	MASTER RELAY
F4	PUMP RELAY
F5	SW. BATT TO CAN MODULES
F6	ENGINE BATTERY
F9	NOT USED

NOTE: INSTALLATION MUST CONFORM TO GOOD SHOP PRACTICES, SAE STANDARDS, RVIA STANDARDS, AND OTHER APPLICABLE STANDARDS.