

△
AP42581
FRONT ACTIVE AIR INPUT/OUTPUT MODULE

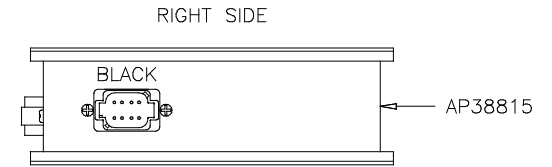
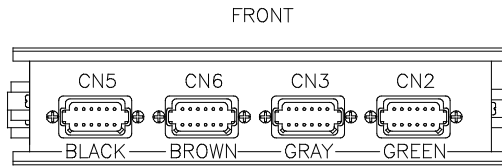
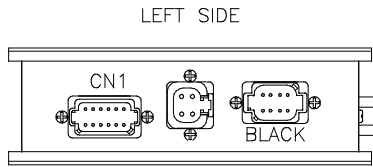

AP38815 CN1 (BROWN)

- PIN
- 1 BLK(W1500) LEFT FRONT RAISE
 - 2 BLK(W1600) LEFT FRONT LOWER
 - 3 BLK(W2500) RIGHT FRONT RAISE
 - 4 BLK(W2600) RIGHT FRONT LOWER
 - 5 BLK(W9700) COMPRESSOR
 - 6 N/C
 - 7 N/C
 - 8 N/C
 - 9 N/C
 - 10 N/C
 - 11 WHT(W6254) GROUND
 - 12 N/C

AP38815 (GRAY)

- PIN
- 1 RED(W6800) SW BATT
 - 2 RED(W6800) SW BATT
 - 3 GRN(W6230) GND
 - 4 GRN(W6230) GND

AP38815 RIGHT SIDE (BLACK)

- PIN
- 1 N/C
 - 2 N/C
 - 3 RED(W6800) SW BATTERY
 - 4 GRN(W6230) GROUND
 - 5 CAN SHIELD
 - 6 N/C
 - 7 GRN CAN LOW
 - 8 YEL CAN HI

AP38815 LEFT SIDE (BLACK)

- PIN
- 1 WHT(W7696) SYSTEM WAKE UP
 - 2 N/C
 - 3 RED(W6800) SW BATTERY
 - 4 GRN(W6230) GROUND
 - 5 CAN SHIELD
 - 6 RED(W6110) IGNITION
 - 7 GRN CAN LOW
 - 8 YEL CAN HI

AP38815 CN5 (BLACK)

- PIN
- 1 BLK(W5703) ROOM 1 ROOM IN
 - 2 BLK(W5701) ROOM 1 ROOM OUT
 - 3 BLK(W5651) ROOM 1 VACUUM SENSOR
 - 4 BLK(W5702) ROOM 4 ROOM IN
 - 5 BLK(W5700) ROOM 4 ROOM OUT
 - 6 WHT(W7501) EXTEND (ROOM 1 AND 4)
 - 7 WHT(W7502) RETRACT (ROOM 1 AND 4)
 - 8 BLK(W5652) ROOM 4 VACUUM SENSOR
 - 9 N/C
 - 10 N/C
 - 11 N/C
 - 12 N/C

AP38815 CN6 (BROWN)

- PIN
- 1 BLK(W6800) SW. +12V
 - 2 N/C
 - 3 N/C
 - 4 BLK(W7510) READY TO OPERATE
 - 5 BLK(W7530) PUMP
 - 6 WHT(W6236) GROUND
 - 7 BLK(W6805) SW BATTERY
 - 8 BLK(W7696) SYSTEM WAKE UP
 - 9 N/C
 - 10 N/C
 - 11 N/C
 - 12 N/C

AP38815 CN3 (GRAY)

- PIN
- 1 BLK(W1100) RIDE HEIGHT LOW
 - 2 BLK(W1101) RIDE HEIGHT MEDIUM
 - 3 BLK(W1102) RIDE HEIGHT HIGH
 - 4 BLK(W1103) ENCODE A
 - 5 BLK(W1104) ENCODE B
 - 6 N/C
 - 7 N/C
 - 8 BLK(W7400) STEERING A
 - 9 BLK(W7401) STEERING B
 - 10 BLK(W7521) TAG DUMP
 - 11 N/C
 - 12 BLK(W6806) ROOM SELECT

AP38815 CN2 (GREEN)

- PIN
- 1 RED(W6120) SW. BATT
 - 2 BLK(W6900) +5V OUTPUT
 - 3 BLK(W6901) +5V OUTPUT
 - 4 N/C
 - 5 N/C
 - 6 WHT(W6235) GROUND
 - 7 RED(W6121) SW. BATT
 - 8 N/C
 - 9 N/C
 - 10 N/C
 - 11 BLK(W2220) RIGHT FRONT TRANSDUCER
 - 12 BLK(W1220) LEFT FRONT TRANSDUCER

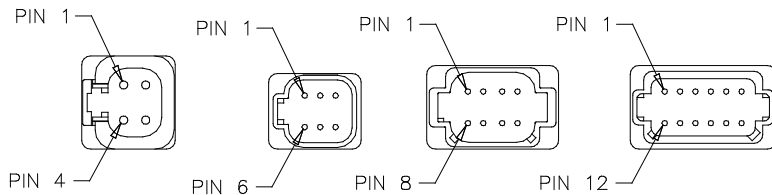

NOTE: DEUTSCH PIN NUMBERS TYPICAL UNLESS OTHERWISE NOTED

NOTE: INSTALLATION MUST CONFORM TO GOOD SHOP PRACTICES, SAE STANDARDS, RVIA STANDARDS, AND OTHER APPLICABLE STANDARDS.

		HWH 1-80 EXIT 267 SOUTH RT 1 MOSCOW, IOWA 52760	
△	15SEP09	WAS AP41529	SCALE 1:3 DATE 16JUN08 DRAWN BY .
△	20NOV08	WAS AP39347	SYSTEM SCHEMATIC ELEC
NO.	DATE	REVISION	
THE INFORMATION DISCLOSED ON THIS DRAWING IS CONFIDENTIAL AND MUST NOT BE DISCLOSED OR USED IN ANY MANNER WHICH WILL BE DETRIMENTAL TO THE HWH CORPORATION			DRAWING NUMBER MP90174 A/R

AP42904
CENTRAL CONTROL
MODULES

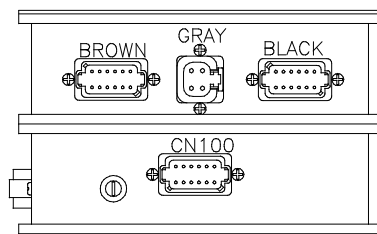
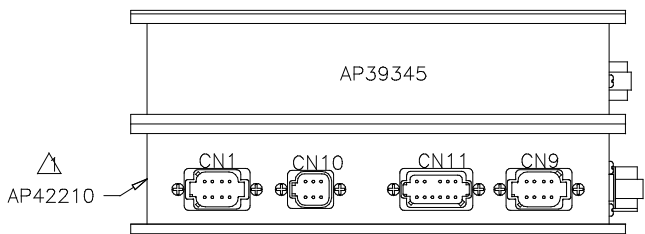

110 NEUTRAL HOLD ENABLED
220 NEUTRAL HOLD DISABLED

AP39345 (BROWN)

PIN	DESCRIPTION
1	BLK(W5050) CYLINDER EXTEND 1
2	BLK(W5150) CYLINDER RETRACT 1
3	BLK(W5600) AIR SEAL ROOM 1
4	BLK(W5650) VACUUM ROOM 1
5	BLK(W5053) CYLINDER EXTEND 4
6	BLK(W5153) CYLINDER RETRACT 4
7	BLK(W5603) AIR SEAL ROOM 4
8	BLK(W5653) VACCUM ROOM 4
9	BLK(W5054) CYLINDER EXTEND GEN
10	BLK(W5154) CYLINDER RETRACT GEN
11	WHT(W6230) GROUND
12	N/C

AP39345 (BLACK)

PIN	DESCRIPTION
1	BLK(W5051) CYLINDER EXTEND 2
2	BLK(W5151) CYLINDER RETRACT 2
3	BLK(W5602) AIR SEAL ROOM 2
4	BLK(W5652) VACUUM ROOM 2
5	N/C
6	N/C
7	N/C
8	N/C
9	N/C
10	N/C
11	WHT(W6231) GROUND
12	N/C

AP42210 CN100(GRAY)

PIN	DESCRIPTION
1	BLK(W5000) GEN SLIDE EXTEND
2	N/C
3	N/C
4	N/C
5	N/C
6	WHT(W6230) GROUND
7	N/C
8	N/C
9	N/C
10	N/C
11	N/C
12	BLK(W5100) GEN SLIDE RETRACT

AP39345 (GRAY)

PIN	DESCRIPTION
1	RED(W6800) SW BATT
2	RED(W6800) SW BATT
3	GRN(W6230) GROUND
4	GRN(W6230) GROUND

AP42210 CN1(BLACK)

PIN	DESCRIPTION
1	WHT(W7696) SYSTEM WAKE UP
2	N/C
3	RED(W6800) SW BATT
4	GRN(W6230) GND
5	CAN SHIELD
6	RED(W6110) IGNITION
7	GRN CAN LOW
8	YEL CAN HI

AP42210 CN10(GRAY)

PIN	DESCRIPTION
1	BLK(W7599) SWITCH LIGHT CONTROL
2	RED(W6100) RESET OUT
3	BLK(W7550) RESET IN
4	RED(W6121) WARN LIGHT SUPPLY
5	WHT(W6230) SWITCH LIGHT SUPPLY
6	BLK(W7699) WARN LIGHT/BUZZER CONTROL

AP42210 CN11(GRAY)

PIN	DESCRIPTION
1	RED(W6110) IGNITION
2	N/C
3	N/C
4	N/C
5	RED(W6120) IGNITION
6	RED(W6100) HOUSE BATTERY
7	GRN(W6230) GROUND
8	WHT(W9961) NEUTRAL HOLD
9	WHT(W9955) NEUTRAL HOLD
10	N/C
11	WHT(W9000) PARK BRAKE SWITCH
12	RED(W6101) HOUSE BATTERY

AP42210 CN9(GREEN)

PIN	DESCRIPTION
1	BLK(W8500) MASTER RELAY CNTRL
2	BLK(W8100) SYSTEM PSW.
3	N/C
4	BLK(W8600) PMP RELAY CNTRL
5	BLK(W9900) SPEED SWITCH
6	BLK(W9901) SW BATT FROM PUMP RELAY
7	N/C
8	N/C

NOTE: INSTALLATION MUST CONFORM TO GOOD SHOP PRACTICES, SAE STANDARDS, RVIA STANDARDS, AND OTHER APPLICABLE STANDARDS.

AP41855
REAR ACTIVE AIR INPUT/OUTPUT MODULE

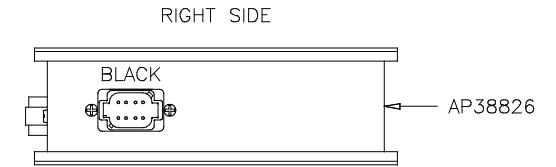
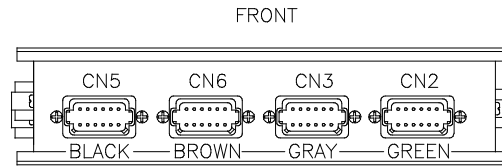
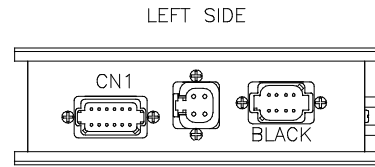

AP38826 CN1 BROWN
PIN

1	BLK(W4500)	LR RAISE
2	BLK(W4600)	LR LOWER
3	BLK(W4550)	LR HIGH VOLUME RAISE
4	BLK(W4601)	LR TAG LOWER
5	BLK(W3500)	RR RAISE
6	BLK(W3600)	RR LOWER
7	BLK(W3550)	RR HIGH VOLUME RAISE
8	BLK(W3601)	RR TAG LOWER
9	BLK(W3800)	TAG LIFT
10	BLK(W3701)	TAG ENABLE
11	WHT(W6258)	GROUND
12	N/C	

AP38826 (GRAY)
PIN

1	RED (W6800)	SW BATT
2	RED (W6800)	SW BATT
3	GRN (W6230)	GND
4	GRN (W6230)	GND

AP38826 BLACK (LEFT SIDE)
PIN

1	WHT(W7696)	SYSTEM WAKE UP
2	N/C	
3	RED(W6800)	SW BATTERY
4	GRN(W6230)	GROUND
5	CAN SHIELD	
6	RED(W6110)	IGNITION
7	GRN CAN LOW	
8	YEL CAN HI	

AP38826 BLACK (RIGHT SIDE)
PIN

1	N/C	
2	N/C	
3	N/C	
4	N/C	
5	N/C	
6	N/C	
7	BLACK 120 ?	RESISTOR
8	BLACK 120 ?	RESISTOR

AP38826 CN5(BLACK)
PIN

1	BLK(W3100)	RR RIDE HEIGHT LOW
2	BLK(W3101)	RR RIDE HEIGHT MEDIUM
3	BLK(W3102)	RR RIDE HEIGHT HIGH
4	BLK(W3103)	RR ENCODE A
5	BLK(W3104)	RR ENCODE B
6	N/C	
7	N/C	
8	N/C	
9	N/C	
10	N/C	
11	N/C	
12	N/C	

AP38826 CN6(BROWN)
PIN

1	RED(W6121)	SW. BATT.
2	BLK(W6908)	+5V OUTPUT
3	BLK(W6909)	+5V OUTPUT
4	N/C	
5	N/C	
6	WHT(W6232)	GROUND
7	RED(W6805)	SW BATTERY
8	N/C	
9	N/C	
10	BLK(W3225)	SYSTEM TRANSDUCER
11	BLK(W3221)	RR TAG TRANSDUCER
12	BLK(W3220)	RR TRANSDUCER

AP38826 CN3(GRAY)
PIN

1	BLK(W4100)	LR RIDE HEIGHT LOW
2	BLK(W4101)	LR RIDE HEIGHT MEDIUM
3	BLK(W4102)	LR RIDE HEIGHT HIGH
4	BLK(W4103)	LR ENCODE A
5	BLK(W4104)	LR ENCODE B
6	BLK(W7501)	EXTEND (ROOM 2)
7	BLK(W7502)	RETRACT (ROOM 2)
8	N/C	
9	N/C	
10	BLK(W5703)	ROOM 2 ROOM IN
11	BLK(W5701)	ROOM 2 ROOM OUT
12	BLK(W5651)	ROOM 2 VACUUM SENSOR

AP38826 CN2(GREEN)
PIN

1	RED(W6120)	SW. BATT
2	BLK(W6912)	+5V OUTPUT
3	BLK(W6913)	+5V OUTPUT
4	BLK(W7510)	READY TO OPERATE
5	BLK(W7530)	PUMP
6	WHT(W6233)	GROUND
7	BLK(W6800)	SW. +12V
8	WHT(W7696)	SYSTEM WAKE UP
9	N/C	
10	N/C	
11	BLK(W4221)	LR TAG TRANSDUCER
12	BLK(W4220)	LR TRANSDUCER

NOTE: INSTALLATION MUST CONFORM TO GOOD SHOP PRACTICES, SAE STANDARDS, RVIA STANDARDS, AND OTHER APPLICABLE STANDARDS.

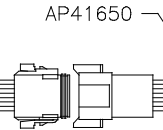
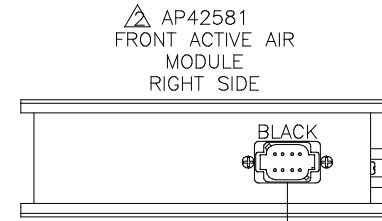
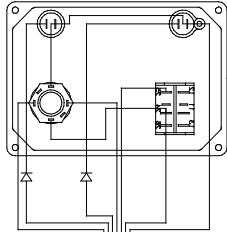
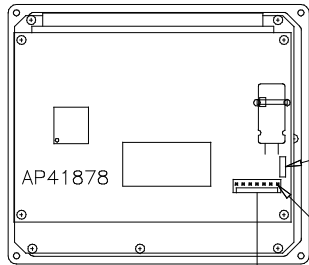
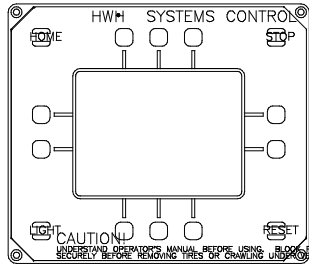

- 7 PIN
1. WHT(W6100) RESET OUT
 2. WHT(W7550) RESET IN
 3. YELLOW CAN HIGH
 4. GREEN CAN LOW
 5. CAN SHIELD
 6. GRN(W6230) GROUND
 7. BLK(W6800) SW. BATTERY

120 OHM
TERMINATION
RESISTOR
PART OF OEM
PROVIDED TRUNK
HARNESS

OEM PROVIDED

OEM PROVIDED

NOTE: INSTALLATION MUST CONFORM TO GOOD SHOP PRACTICES, SAE STANDARDS, RVIA STANDARDS, AND OTHER APPLICABLE STANDARDS.

MP90174 D
15SEP09

AP42581
FRONT ACTIVE AIR MODULE
FRONT SIDE

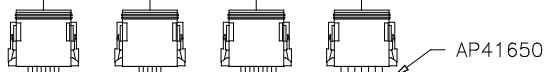
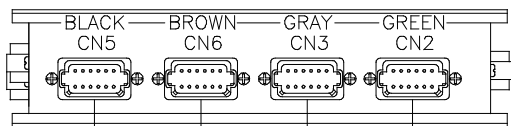

BLK(W1220)
BLK(W6900)
BLK(W2220)

WHT(W6235)
BLK(W6901)

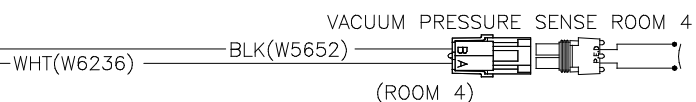

(ROOM 4)

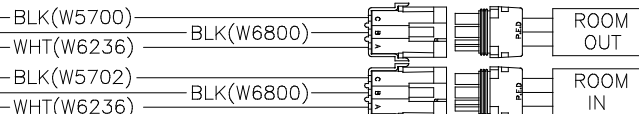

(ROOM 1)

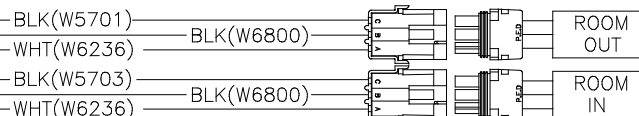

TAG DUMP SWITCH

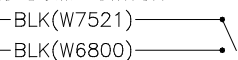

PIN

1. BLK(W7400) STEERING A
2. BLK(W7401) STEERING B
3. RED(W6121) SW. BATT
4. RED(W6120) SW BATT
5. WHT(W6235) GROUND
6. WHT(W6235) GROUND
7. N/C
8. N/C

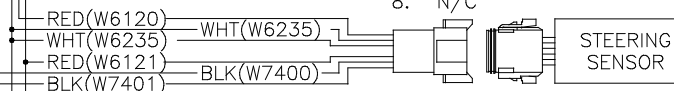

STEERING
SENSOR

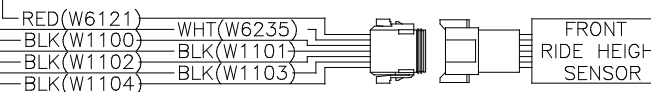

FRONT
RIDE HEIGHT
SENSOR

PIN

1. WHT(W6235) GROUND
2. BLK(W1101) RIDE HEIGHT MED
3. BLK(W1102) RIDE HEIGHT HIGH
4. RED(W6121) SW. BATT
5. BLK(W1100) RIDE HEIGHT LOW
6. BLK(W1103) ENCODE A
7. BLK(W1104) ENCODE B
8. N/C

OEM PROVIDED

NOTE: INSTALLATION MUST CONFORM TO GOOD SHOP PRACTICES, SAE STANDARDS, RVIA STANDARDS, AND OTHER APPLICABLE STANDARDS.

MP90174 E
15SEP09

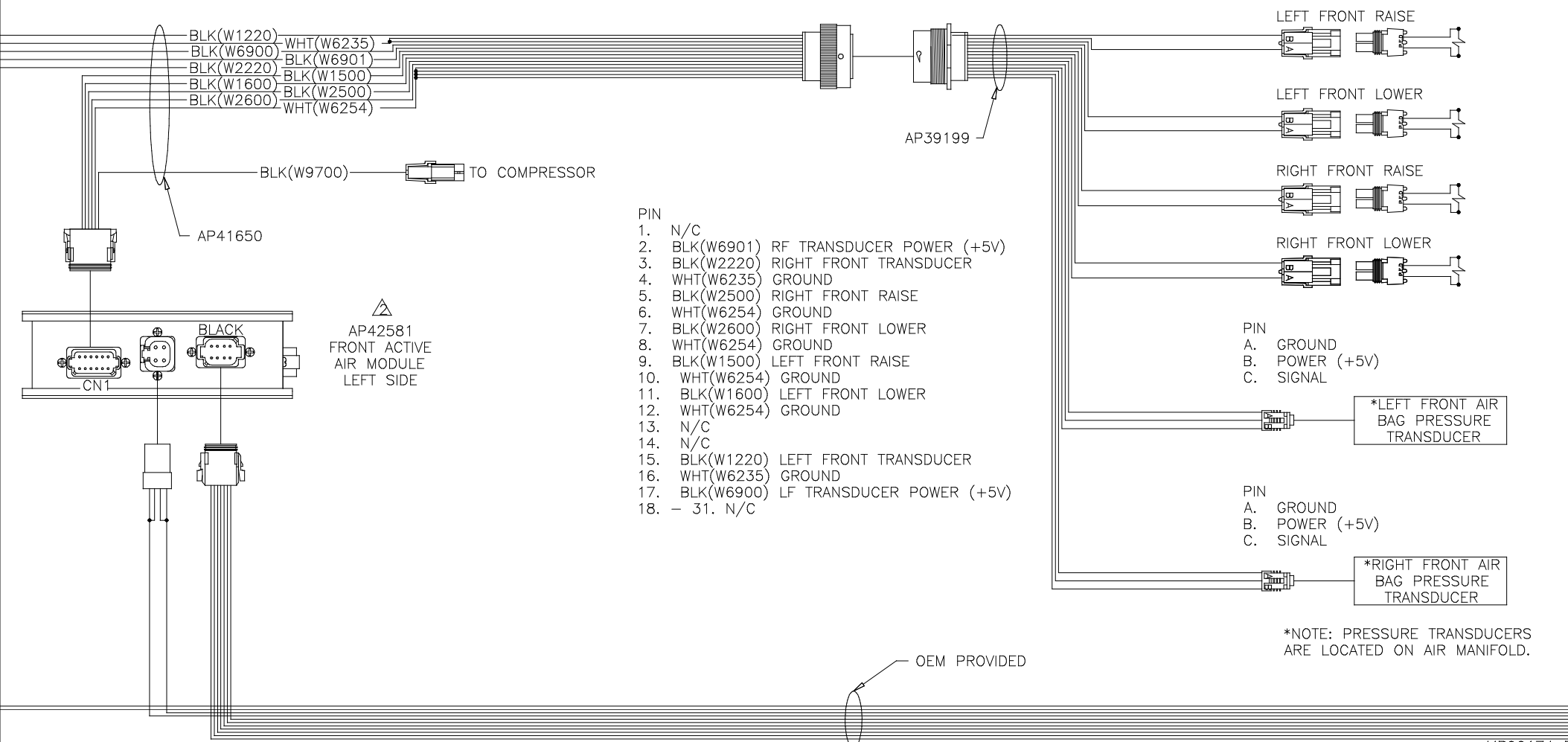

NOTE: INSTALLATION MUST CONFORM TO GOOD SHOP PRACTICES, SAE STANDARDS, RVIA STANDARDS, AND OTHER APPLICABLE STANDARDS.

- TO IGNITION — RED(W6110)
- TO IGNITION — RED(W6120)
- TO HOUSE BATTERY — RED(W6101)
- TO GROUND — GRN(W6230)
- TO PARK BRAKE — WHT(W9000)
- TO HOUSE BATTERY — RED(W6100)
- TO NEUTRAL HOLD — WHT(W9961)
- TO NEUTRAL HOLD — WHT(W9955)

OEM #62464

3000 LB PRESS. SW.

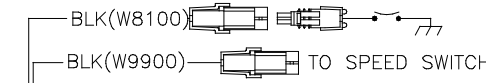

HOUSE BATTERY

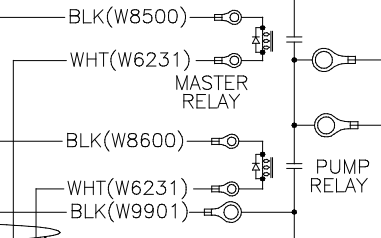

PUMP MOTOR

GROUND STUD

AP42904
CENTRAL CONTROL MODULE
FRONT VIEW

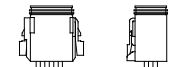
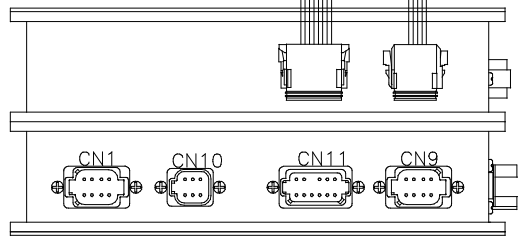

MASTER WARNING LIGHT

GEN SLIDE

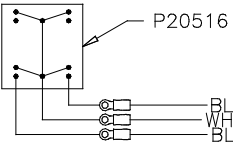

110 NEUTRAL HOLD ENABLED
220 NEUTRAL HOLD DISABLED

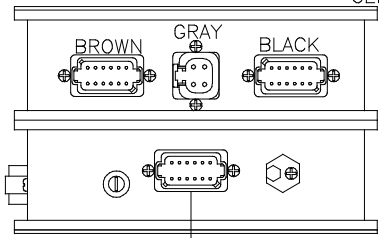

AP42904
CENTRAL CONTROL MODULE
RIGHT VIEW

GROUND STUD

AP41728

AP42884

AP37839

OEM PROVIDED

NOTE: INSTALLATION MUST CONFORM TO GOOD SHOP PRACTICES, SAE STANDARDS, RVIA STANDARDS, AND OTHER APPLICABLE STANDARDS.

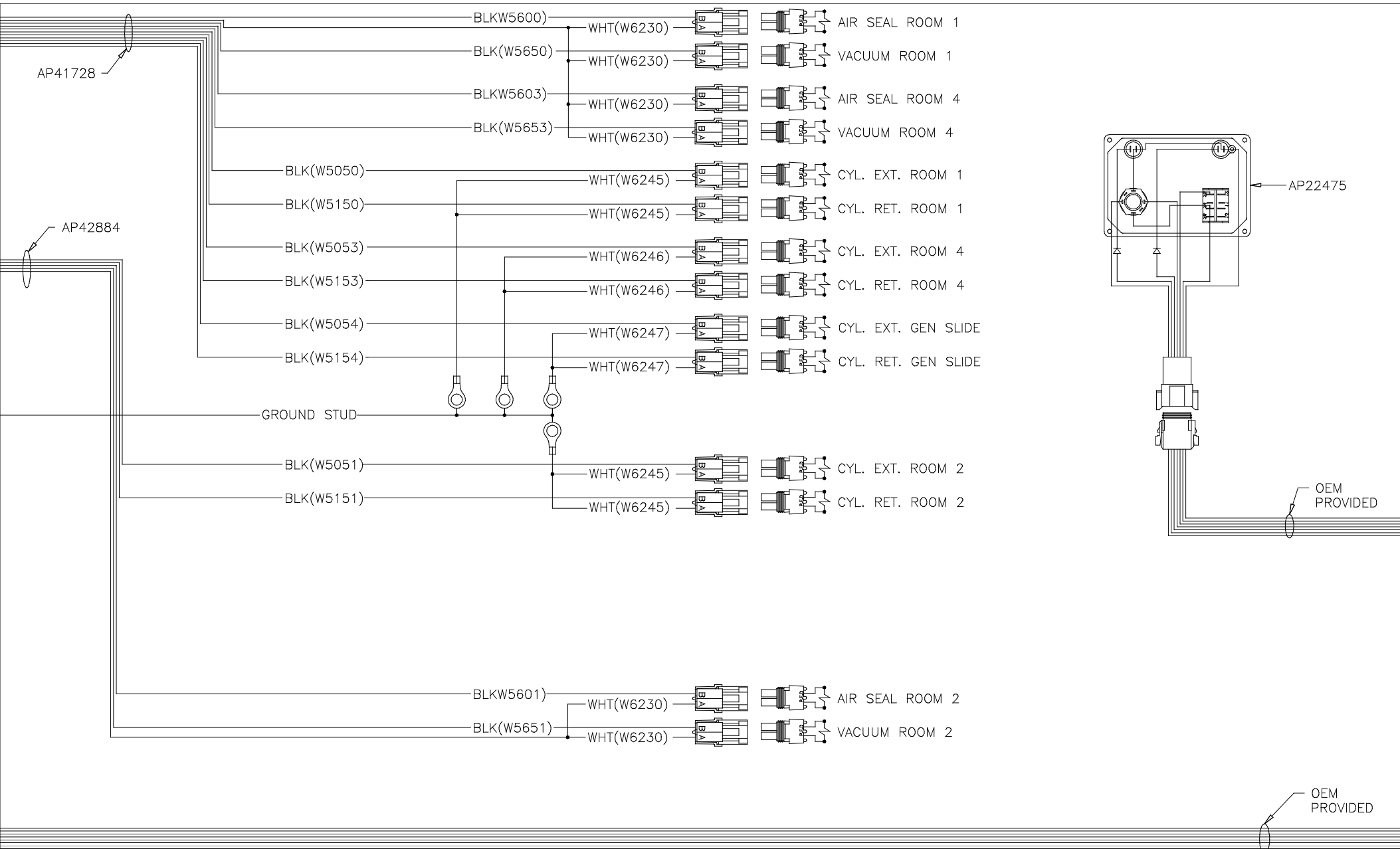

NOTE: INSTALLATION MUST CONFORM TO GOOD SHOP PRACTICES, SAE STANDARDS, RVIA STANDARDS, AND OTHER APPLICABLE STANDARDS.

AP41855
REAR ACTIVE AIR MODULE
FRONT SIDE

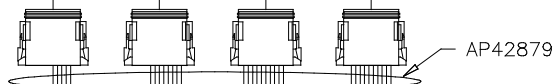
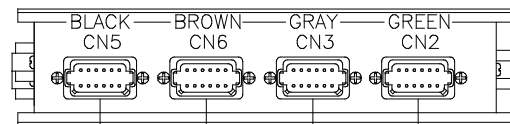

- BLK(W6913) — BLK(W3221)
- BLK(W4220) — BLK(W4221)
- BLK(W6912) — WHT(W6233)
- BLK(W3225) — BLK(W6909)
- WHT(W6232) — BLK(W6908)
- BLK(W3220)

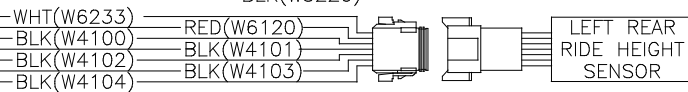

- PIN
- | | |
|-----------------------------------|---------------------------------|
| 1. WHT(W6233) GROUND | 5. BLK(4100) LR RIDE HEIGHT LOW |
| 2. BLK(W4101) LR RIDE HEIGHT MED | 6. BLK(4103) LR ENCODE A |
| 3. BLK(W4102) LR RIDE HEIGHT HIGH | 7. BLK(4104) LR ENCODE B |
| 4. RED(W6120) SW. BATT | 8. N/C |

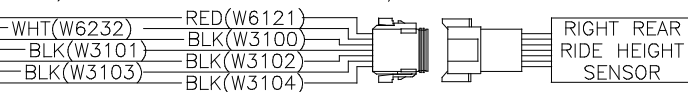

- PIN
- | | |
|----------------------------------|----------------------------------|
| 1. WHT(W6232) GROUND | 5. RED(W3100) RR RIDE HEIGHT LOW |
| 2. BLK(W3101) RR RIDE HEIGHT MED | 6. BLK(W3103) RR ENCODE A |
| 3. BLK(W3102) RR RIDE HEIGHT HI | 7. BLK(W3104) RR ENCODE B |
| 4. RED(W6121) SW. BATT | 8. N/C |

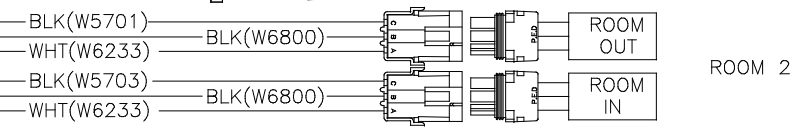
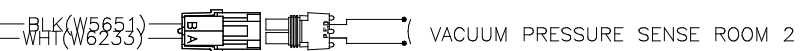

OEM PROVIDED

OEM PROVIDED

NOTE: INSTALLATION MUST CONFORM TO GOOD SHOP PRACTICES, SAE STANDARDS, RVIA STANDARDS, AND OTHER APPLICABLE STANDARDS.

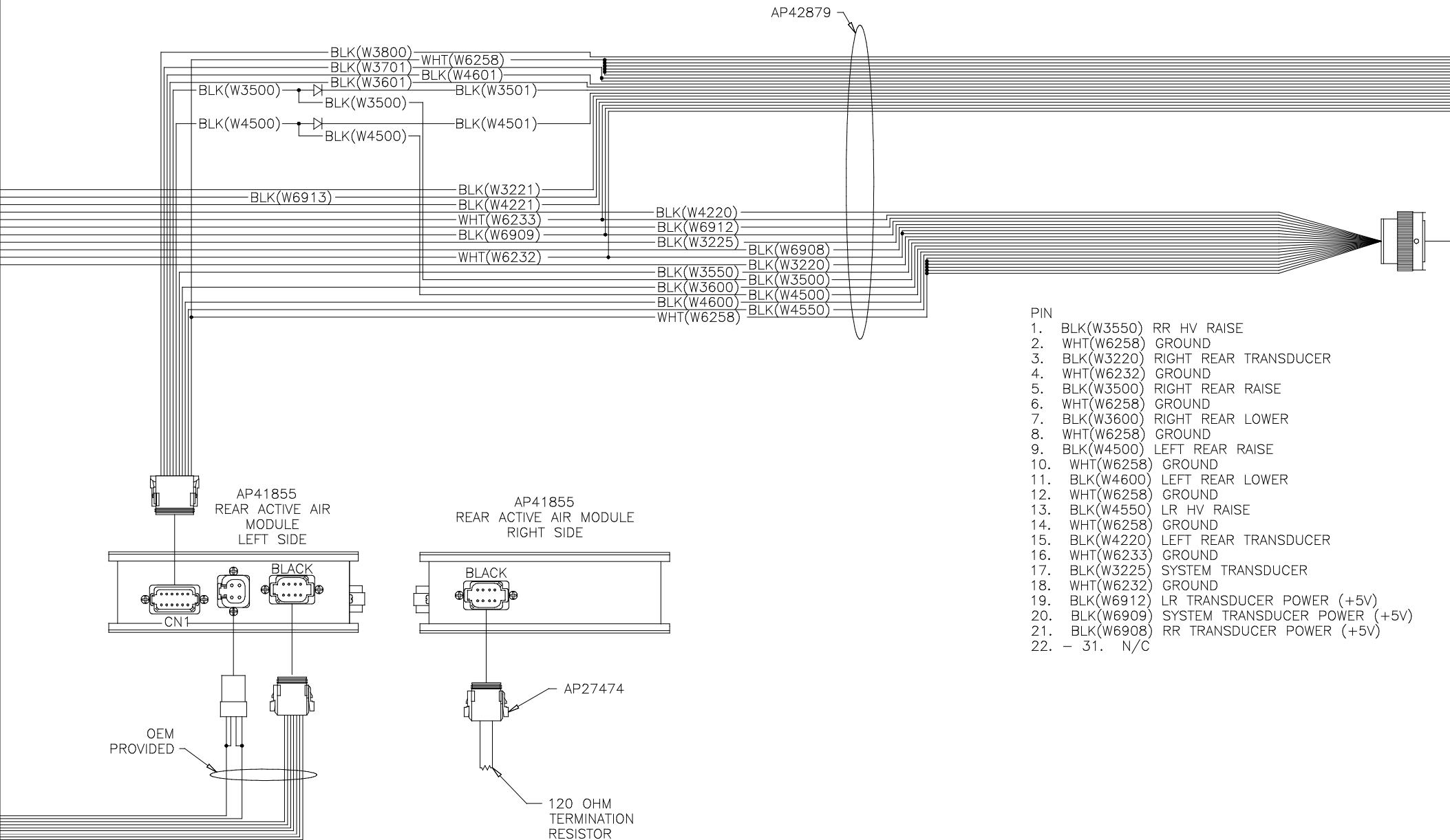

NOTE: INSTALLATION MUST CONFORM TO GOOD SHOP PRACTICES, SAE STANDARDS, RVIA STANDARDS, AND OTHER APPLICABLE STANDARDS.

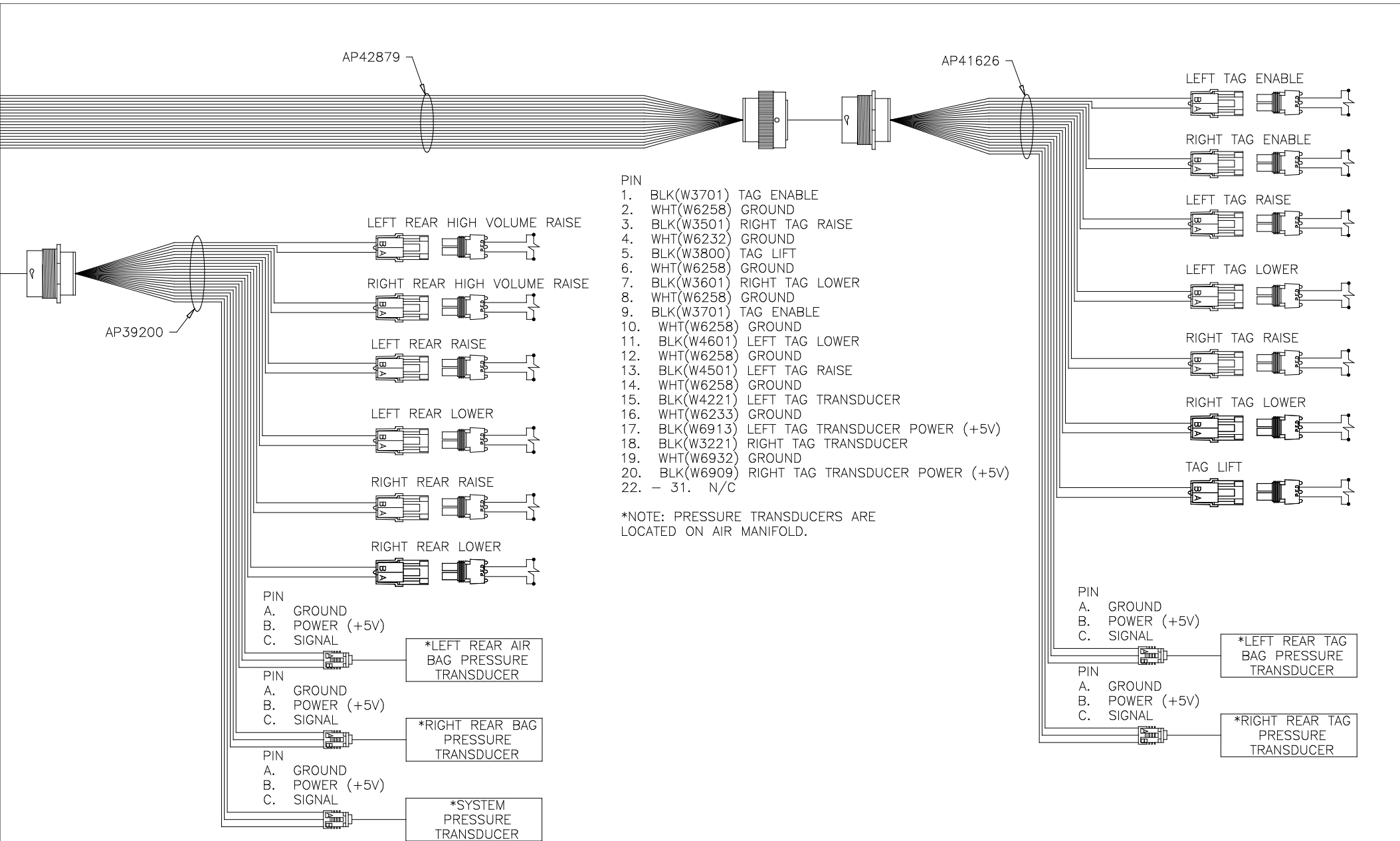

NOTE: INSTALLATION MUST CONFORM TO GOOD SHOP PRACTICES, SAE STANDARDS, RVIA STANDARDS, AND OTHER APPLICABLE STANDARDS.

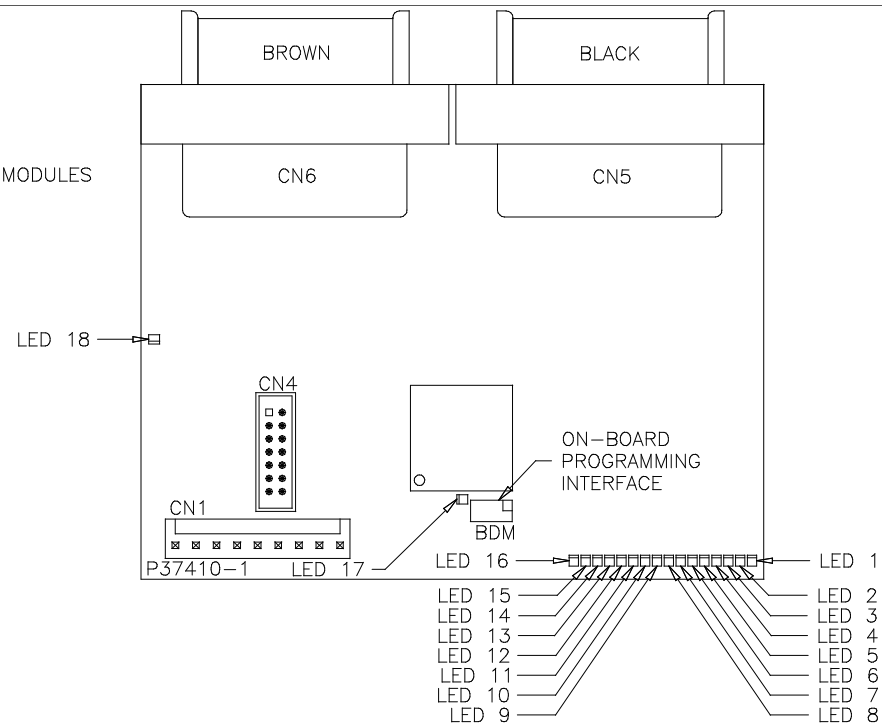
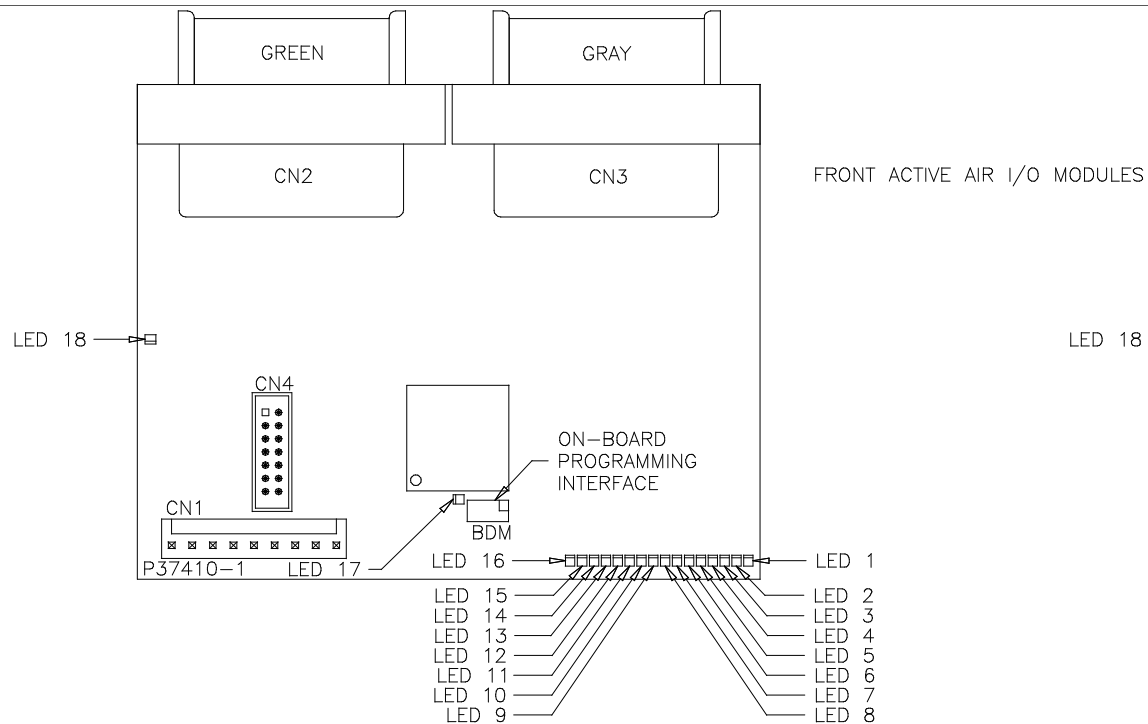

LED #	CONNECTOR	COLOR	DESCRIPTION
LED 1	CN3 PIN 1	RED	FRONT RIDE HEIGHT LOW
LED 2	CN3 PIN 2	GREEN	FRONT RIDE HEIGHT MED
LED 3	CN3 PIN 3	YELLOW	FRONT RIDE HEIGHT HIGH
LED 4	CN3 PIN 4	RED	ENCODE A
LED 5	CN3 PIN 5	GREEN	ENCODE B
LED 6	NOT USED	YELLOW	NOT USED
LED 7	NOT USED	RED	NOT USED
LED 8	CN3 PIN 8	GREEN	STEERING A
LED 9	CN3 PIN 9	YELLOW	STEERING B
LED 10	CN3 PIN 10	RED	TAG DUMP
LED 11	NOT USED	GREEN	NOT USED
LED 12	CN3 PIN 12	YELLOW	ROOM SELECT
LED 13	NOT USED	RED	NOT USED
LED 14	NOT USED	GREEN	NOT USED
LED 15	NOT USED	YELLOW	NOT USED
LED 16	NOT USED	RED	NOT USED
LED 17	NOT APPLICABLE	RED	LINK LIGHT
LED 18	NOT APPLICABLE	RED	POWER TO CAN MODULES

LED #	CONNECTOR	COLOR	DESCRIPTION
LED 1	CN5 PIN 1	RED	ROOM 1 ROOM IN
LED 2	CN5 PIN 2	GREEN	ROOM 1 ROOM OUT
LED 3	CN5 PIN 3	YELLOW	ROOM 1 VACUUM SENSOR
LED 4	CN5 PIN 4	RED	ROOM 4 ROOM IN
LED 5	CN5 PIN 5	GREEN	ROOM 4 ROOM OUT
LED 6	CN5 PIN 6	YELLOW	EXTEND (ROOM 1 AND 4)
LED 7	CN5 PIN 7	RED	RETRACT (ROOM 1 AND 4)
LED 8	CN5 PIN 8	GREEN	ROOM 4 VACUUM SENSOR
LED 9	NOT USED	YELLOW	NOT USED
LED 10	NOT USED	RED	NOT USED
LED 11	NOT USED	GREEN	NOT USED
LED 12	NOT USED	YELLOW	NOT USED
LED 13	NOT USED	RED	NOT USED
LED 14	NOT USED	GREEN	NOT USED
LED 15	NOT USED	YELLOW	NOT USED
LED 16	CN6 PIN 8	RED	SYSTEM WAKE UP
LED 17	NOT APPLICABLE	RED	LINK LIGHT
LED 18	NOT APPLICABLE	RED	POWER TO CAN MODULES

NOTE: INSTALLATION MUST CONFORM TO GOOD SHOP PRACTICES, SAE STANDARDS, RVIA STANDARDS, AND OTHER APPLICABLE STANDARDS.

MP90174 L
16JUN08

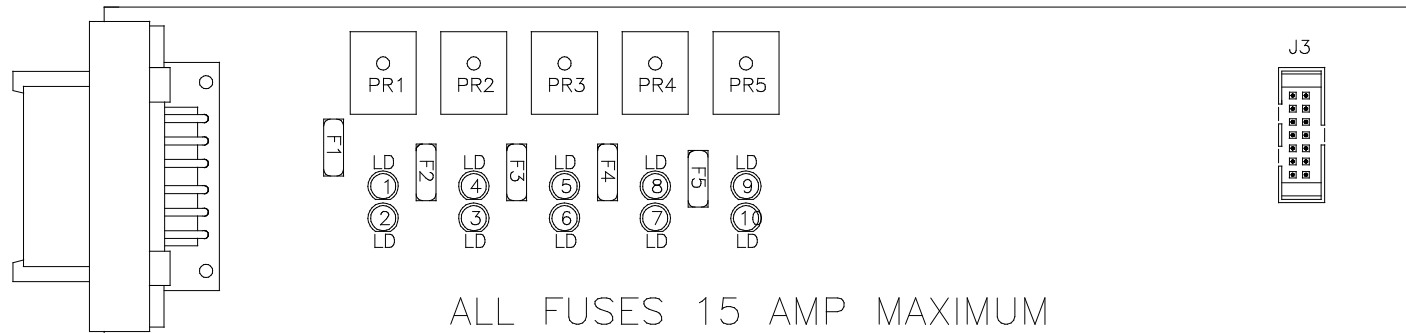

FRONT AIR
LED LAYOUT

LED #	COLOR	FUSE #	OUTPUT	RELAY #	DESCRIPTION
LED1	YELLOW	---	---	PR1	LEFT FRONT RAISE (CONTACT)
LED2	RED	FUSE 1	PIN 1	PR1	LEFT FRONT RAISE (COIL)
LED3	RED	FUSE 2	PIN 2	PR2	LEFT FRONT LOWER (COIL)
LED4	YELLOW	---	---	PR2	LEFT FRONT LOWER (CONTACT)
LED5	YELLOW	---	---	PR3	RIGHT FRONT RAISE (CONTACT)
LED6	RED	FUSE 3	PIN 3	PR3	RIGHT FRONT RAISE (COIL)
LED7	RED	FUSE 4	PIN 4	PR4	RIGHT FRONT LOWER (COIL)
LED8	YELLOW	---	---	PR4	RIGHT FRONT LOWER (CONTACT)
LED9	YELLOW	---	---	PR5	COMPRESSOR (CONTACT)
LED10	RED	FUSE 5	PIN 5	PR5	COMPRESSOR (COIL)

GENERATOR SLIDE/STEP COVER
REED SWITCH
LAYOUT

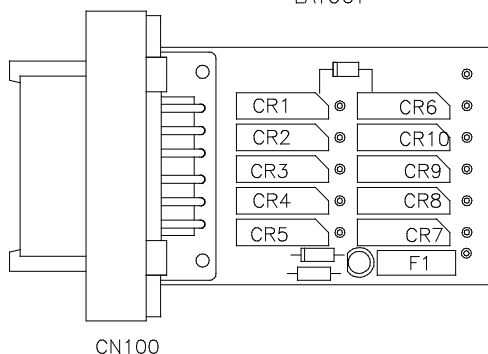

CONNECTOR	REED SWITCH	DESCRIPTION
CN 100 PIN 1	CR1	GEN SLIDE EXTEND
CN 100 PIN 2	CR2	NOT USED
CN 100 PIN 3	CR3	NOT USED
CN 100 PIN 4	CR4	NOT USED
CN 100 PIN 5	CR5	NOT USED
CN 100 PIN 6	---	GROUND
CN 100 PIN 7	---	NOT USED
CN 100 PIN 8	CR7	NOT USED
CN 100 PIN 9	CR8	NOT USED
CN 100 PIN 10	CR9	NOT USED
CN 100 PIN 11	CR10	NOT USED
CN 100 PIN 12	CR6	GEN SLIDE RETRACT

NOTE: INSTALLATION MUST CONFORM TO GOOD SHOP PRACTICES, SAE STANDARDS, RVIA STANDARDS, AND OTHER APPLICABLE STANDARDS.

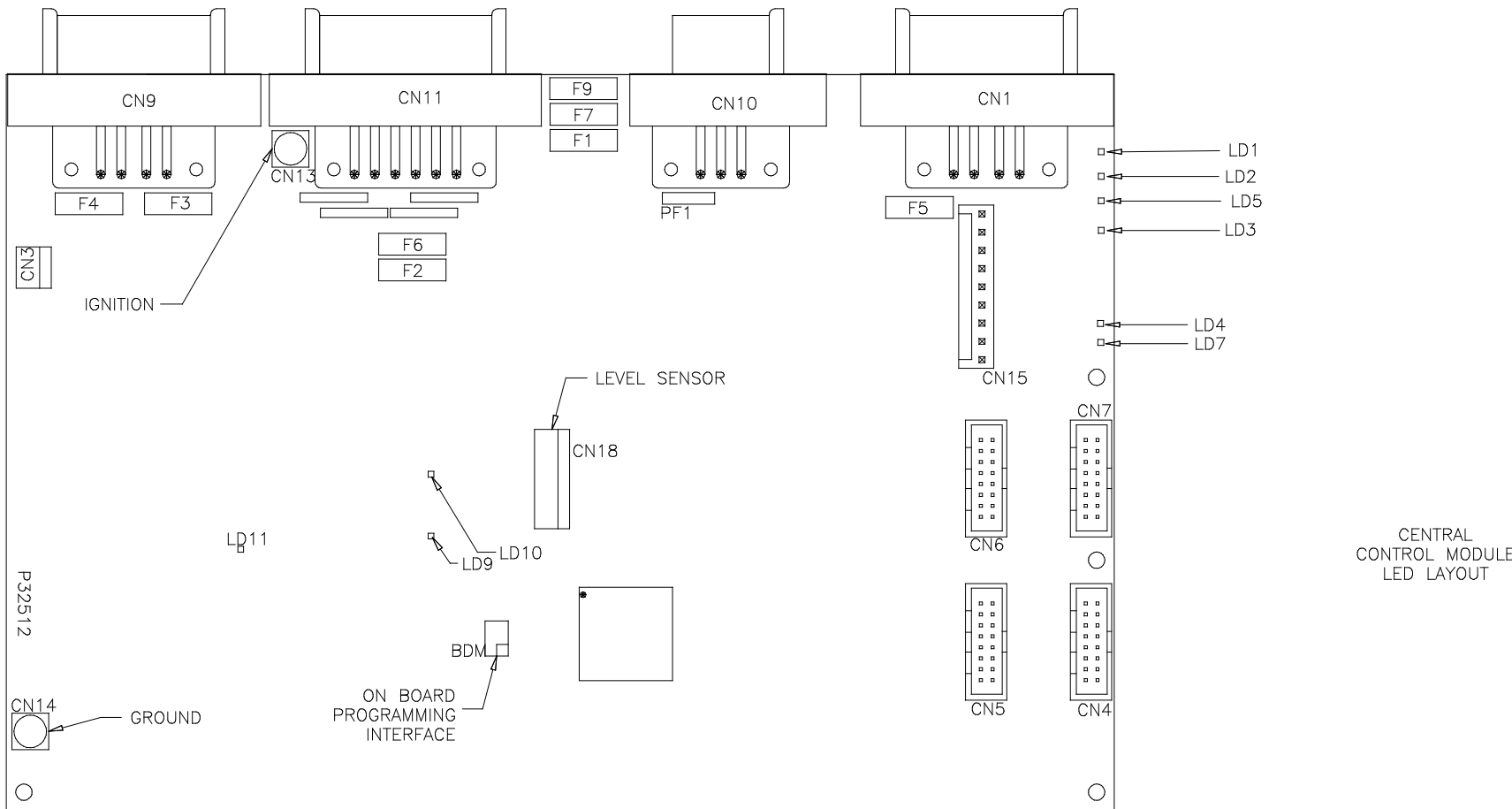

CENTRAL CONTROL MODULE LED LAYOUT

LED #	CONNECTOR	COLOR	DESCRIPTION
LED 1	CN 9 PIN 1	RED	MASTER RELAY
LED 2	CN 9 PIN 4	RED	PUMP RELAY
LED 3	CN 1 PIN 3	RED	SW 12V
LED 4	CN 11 PIN 12	RED	ENGINE BATT
LED 5	CN 9 PIN 5	RED	SPEED SWITCH
LED 7	CN 1 PIN 7 & 8	RED	LINK LIGHT
LED 8	CN 11 PIN 8 & 9	RED	NEUTRAL HOLD
LED 9	NOT USED	NOT USED	NOT USED
LED 10	CN9 PIN 2	RED	3000 LBS. PSW
LED 11	CN11 PIN 11	RED	PARK BRAKE

FUSE #	DESCRIPTION
PF1	RESET OUT
F7	ACCESSORY
F1	IGNITION
F2	HOUSE BATTERY
F3	MASTER RELAY
F4	PUMP RELAY
F5	SW. BATT TO CAN MODULES
F6	ENGINE BATTERY
F9	POWER TO CN100

NOTE: INSTALLATION MUST CONFORM TO GOOD SHOP PRACTICES, SAE STANDARDS, RVIA STANDARDS, AND OTHER APPLICABLE STANDARDS.

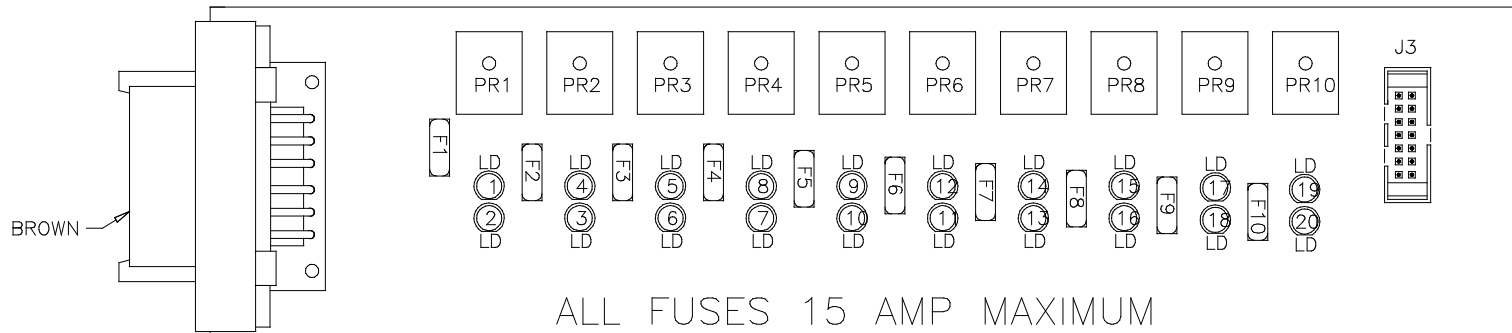

ROOM OUTPUTS
LED LAYOUT

LED #	COLOR	FUSE #	OUTPUT	RELAY #	DESCRIPTION
LED1	YELLOW	---	---	PR1	CYLINDER EXTEND 1 (COIL)
LED2	RED	FUSE 1	PIN 1	PR1	CYLINDER EXTEND 1 (CONTACT)
LED3	RED	FUSE 2	PIN 2	PR2	CYLINDER RETRACT 1 (CONTACT)
LED4	YELLOW	---	---	PR2	CYLINDER RETRACT 1 (COIL)
LED5	YELLOW	---	---	PR3	AIR SEAL ROOM 1 (COIL)
LED6	RED	FUSE 3	PIN 3	PR3	AIR SEAL ROOM 1 (CONTACT)
LED7	RED	FUSE 4	PIN 4	PR4	VACUUM ROOM 1 (CONTACT)
LED8	YELLOW	---	---	PR4	VACUUM ROOM 1 (COIL)
LED9	YELLOW	---	---	PR5	CYLINDER EXTEND 4 (COIL)
LED10	RED	FUSE 5	PIN 5	PR5	CYLINDER EXTEND 4 (CONTACT)
LED11	RED	FUSE 6	PIN 6	PR6	CYLINDER RETRACT 4 (CONTACT)
LED12	YELLOW	---	---	PR6	CYLINDER RETRACT 4 (COIL)
LED13	RED	FUSE 7	PIN 7	PR7	AIR SEAL ROOM 4 (COIL)
LED14	YELLOW	---	---	PR7	AIR SEAL ROOM 4 (CONTACT)
LED15	YELLOW	---	---	PR8	VACCUM ROOM 4 (CONTACT)
LED16	RED	FUSE 8	PIN 8	PR8	VACCUM ROOM 4 (COIL)
LED17	YELLOW	---	---	PR9	CYLINDER EXTEND GEN (COIL)
LED18	RED	FUSE 9	PIN 9	PR9	CYLINDER EXTEND GEN (CONTACT)
LED19	YELLOW	---	---	PR10	CYLINDER RETRACT GEN (CONTACT)
LED20	RED	FUSE 10	PIN 10	PR10	CYLINDER RETRACT GEN (COIL)

NOTE: INSTALLATION MUST CONFORM TO GOOD SHOP PRACTICES, SAE STANDARDS, RVIA STANDARDS, AND OTHER APPLICABLE STANDARDS.

MP90174 0
16JUN08

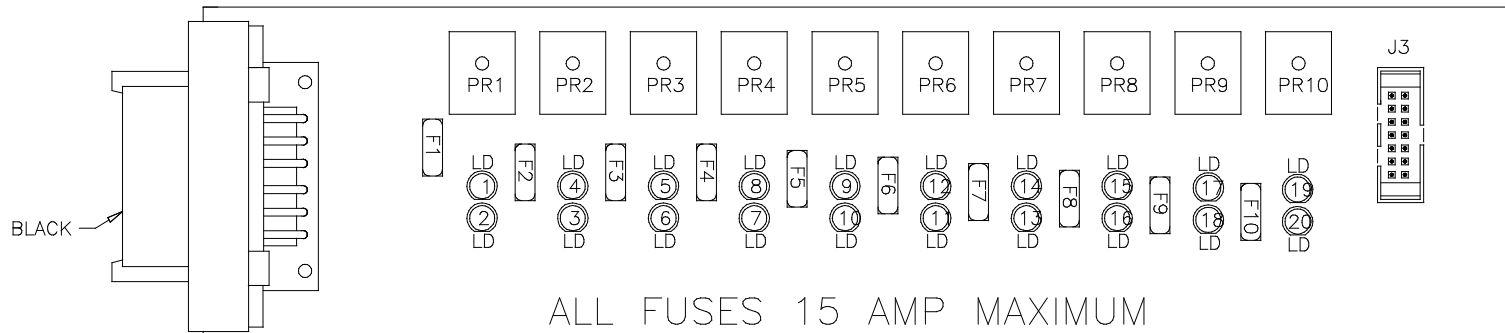

ROOM OUTPUTS
LED LAYOUT

LED #	COLOR	FUSE #	OUTPUT	RELAY #	DESCRIPTION
LED1	YELLOW	---	---	PR1	CYLINDER EXTEND 2 (COIL)
LED2	RED	FUSE 1	PIN 1	PR1	CYLINDER EXTEND 2 (CONTACT)
LED3	RED	FUSE 2	PIN 2	PR2	CYLINDER RETRACT 2 (CONTACT)
LED4	YELLOW	---	---	PR2	CYLINDER RETRACT 2 (COIL)
LED5	YELLOW	---	---	PR3	AIR SEAL ROOM 2 (COIL)
LED6	RED	FUSE 3	PIN 3	PR3	AIR SEAL ROOM 2 (CONTACT)
LED7	RED	FUSE 4	PIN 4	PR4	VACUUM ROOM 2 (CONTACT)
LED8	YELLOW	---	---	PR4	VACUUM ROOM 2 (COIL)
LED9	YELLOW	---	---	PR5	NOT USED
LED10	RED	FUSE 5	PIN 5	PR5	NOT USED
LED11	RED	FUSE 6	PIN 6	PR6	NOT USED
LED12	YELLOW	---	---	PR6	NOT USED
LED13	RED	FUSE 7	PIN 7	PR7	NOT USED
LED14	YELLOW	---	---	PR7	NOT USED
LED15	YELLOW	---	---	PR8	NOT USED
LED16	RED	FUSE 8	PIN 8	PR8	NOT USED
LED17	YELLOW	---	---	PR9	NOT USED
LED18	RED	FUSE 9	PIN 9	PR9	NOT USED
LED19	YELLOW	---	---	PR10	NOT USED
LED20	RED	FUSE 10	PIN 10	PR10	NOT USED

NOTE: INSTALLATION MUST CONFORM TO GOOD SHOP PRACTICES, SAE STANDARDS, RVIA STANDARDS, AND OTHER APPLICABLE STANDARDS.

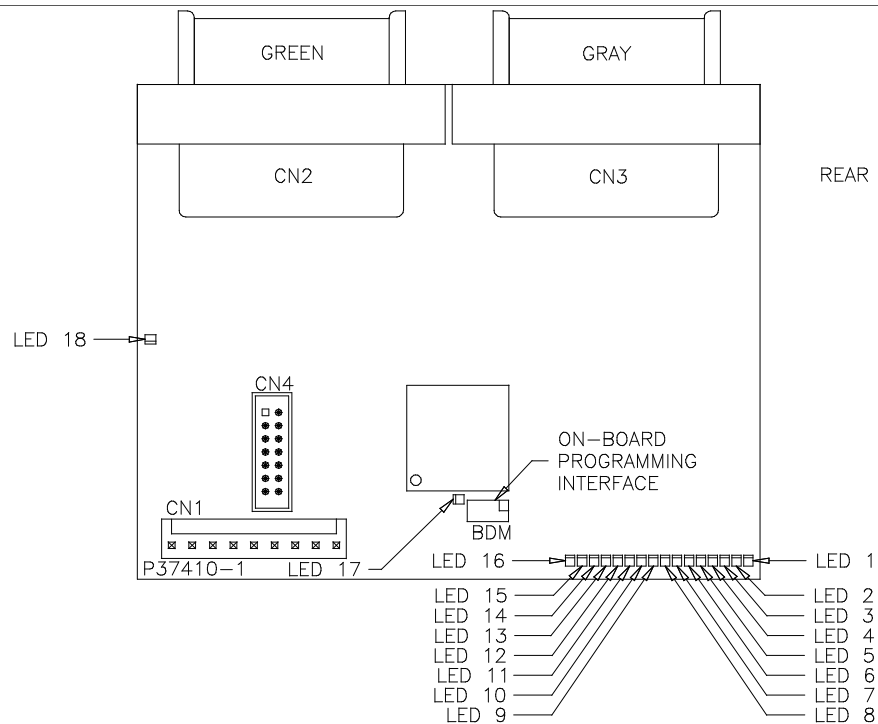

REAR ACTIVE AIR I/O MODULES

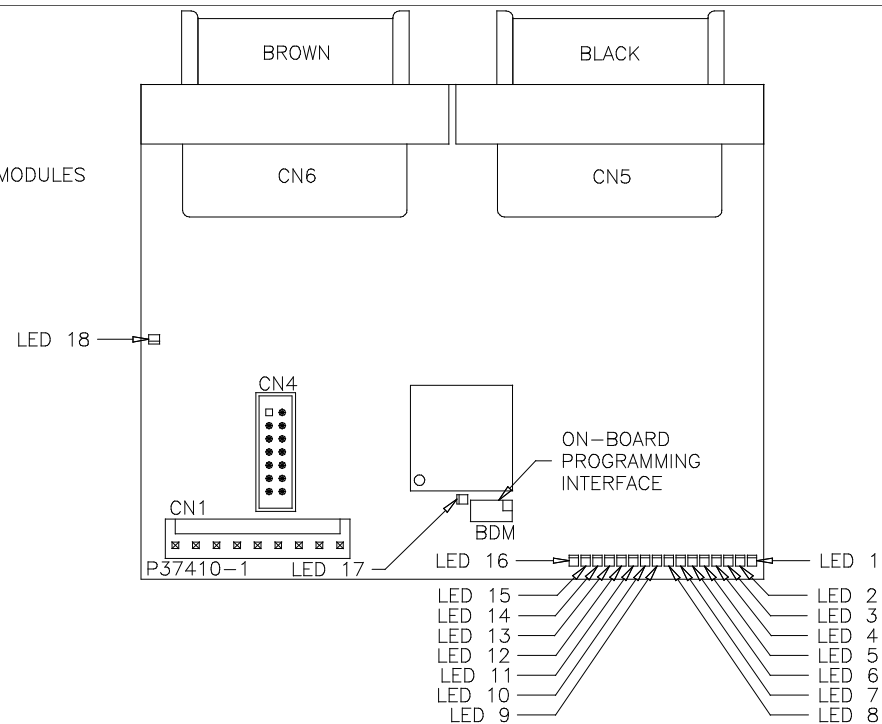

LED #	CONNECTOR	COLOR	DESCRIPTION
LED 1	CN3 PIN 1	RED	LR RIDE HEIGHT LOW
LED 2	CN3 PIN 2	GREEN	LR RIDE HEIGHT MED
LED 3	CN3 PIN 3	YELLOW	LR RIDE HEIGHT HIGH
LED 4	CN3 PIN 4	RED	LR ENCODE A
LED 5	CN3 PIN 5	GREEN	LR ENCODE B
LED 6	CN3 PIN 6	YELLOW	EXTEND (ROOM 2)
LED 7	CN3 PIN 7	RED	RETRACT (ROOM 2)
LED 8	NOT USED	GREEN	NOT USED
LED 9	NOT USED	YELLOW	NOT USED
LED 10	CN3 PIN 10	RED	ROOM 2 ROOM IN
LED 11	CN3 PIN 11	GREEN	ROOM 2 ROOM OUT
LED 12	CN3 PIN 12	YELLOW	ROOM 2 VACUUM SENSOR
LED 13	NOT USED	RED	NOT USED
LED 14	NOT USED	GREEN	NOT USED
LED 15	NOT USED	YELLOW	NOT USED
LED 16	CN2 PIN 8	RED	SYSTEM WAKE UP
LED 17	NOT APPLICABLE	RED	LINK LIGHT
LED 18	NOT APPLICABLE	RED	POWER TO CAN MODULES

LED #	CONNECTOR	COLOR	DESCRIPTION
LED 1	CN5 PIN 1	RED	RR RIDE HEIGHT LOW
LED 2	CN5 PIN 2	GREEN	RR RIDE HEIGHT MED
LED 3	CN5 PIN 3	YELLOW	RR RIDE HEIGHT HIGH
LED 4	CN5 PIN 4	RED	RR ENCODE A
LED 5	CN5 PIN 5	GREEN	RR ENCODE B
LED 6	NOT USED	YELLOW	NOT USED
LED 7	NOT USED	RED	NOT USED
LED 8	NOT USED	GREEN	NOT USED
LED 9	NOT USED	YELLOW	NOT USED
LED 10	NOT USED	RED	NOT USED
LED 11	NOT USED	GREEN	NOT USED
LED 12	NOT USED	YELLOW	NOT USED
LED 13	NOT USED	RED	NOT USED
LED 14	NOT USED	GREEN	NOT USED
LED 15	NOT USED	YELLOW	NOT USED
LED 16	NOT USED	RED	NOT USED
LED 17	NOT APPLICABLE	RED	LINK LIGHT
LED 18	NOT APPLICABLE	RED	POWER TO CAN MODULES

NOTE: INSTALLATION MUST CONFORM TO GOOD SHOP PRACTICES, SAE STANDARDS, RVIA STANDARDS, AND OTHER APPLICABLE STANDARDS.

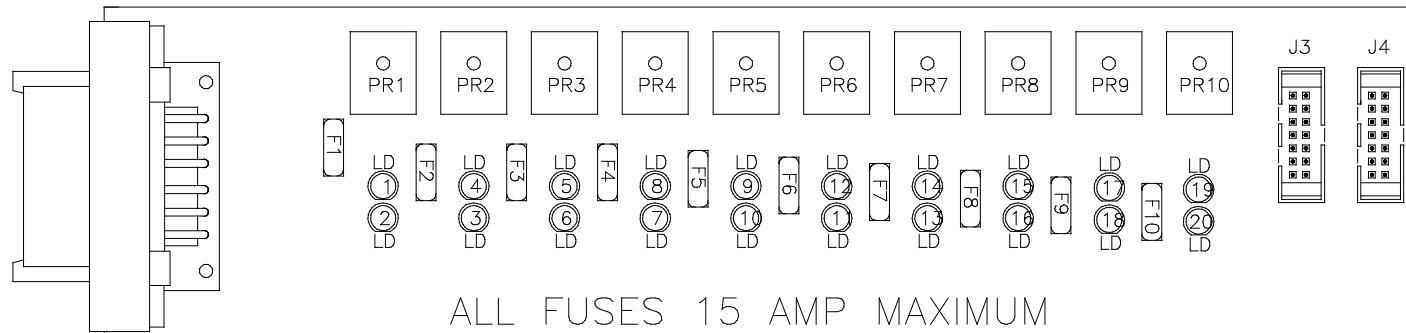

REAR AIR
LED LAYOUT

LED #	COLOR	FUSE #	OUTPUT	RELAY #	DESCRIPTION
LED1	YELLOW	---	---	PR1	LEFT REAR RAISE (COIL)
LED2	RED	FUSE 1	PIN 1	PR1	LEFT REAR RAISE (CONTACT)
LED3	RED	FUSE 2	PIN 2	PR2	LEFT REAR LOWER (CONTACT)
LED4	YELLOW	---	---	PR2	LEFT REAR LOWER (COIL)
LED5	YELLOW	---	---	PR3	LEFT REAR HIGH VOL RAISE (COIL)
LED6	RED	FUSE 3	PIN 3	PR3	LEFT REAR HIGH VOL RAISE (CONTACT)
LED7	RED	FUSE 4	PIN 4	PR4	LEFT REAR TAG LOWER (CONTACT)
LED8	YELLOW	---	---	PR4	LEFT REAR TAG LOWER (COIL)
LED9	YELLOW	---	---	PR5	RIGHT REAR RAISE (COIL)
LED10	RED	FUSE 5	PIN 5	PR5	RIGHT REAR RAISE (CONTACT)
LED11	RED	FUSE 6	PIN 6	PR6	RIGHT REAR LOWER (CONTACT)
LED12	YELLOW	---	---	PR6	RIGHT REAR LOWER (COIL)
LED13	RED	FUSE 7	PIN 7	PR7	RIGHT REAR HIGH VOL RAISE (COIL)
LED14	YELLOW	---	---	PR7	RIGHT REAR HIGH VOL RAISE (CONTACT)
LED15	YELLOW	---	---	PR8	RIGHT REAR TAG LOWER (CONTACT)
LED16	RED	FUSE 8	PIN 8	PR8	RIGHT REAR TAG LOWER (COIL)
LED17	YELLOW	---	---	PR9	TAG DUMP (COIL)
LED18	RED	FUSE 9	PIN 9	PR9	TAG DUMP (CONTACT)
LED19	YELLOW	---	---	PR10	TAG ENABLE (CONTACT)
LED20	RED	FUSE 10	PIN 10	PR10	TAG ENABLE (COIL)

NOTE: INSTALLATION MUST CONFORM TO GOOD SHOP PRACTICES, SAE STANDARDS, RVIA STANDARDS, AND OTHER APPLICABLE STANDARDS.

MP90174 R
16JUN08