

DETAIL 'A'

- PIN
- A) WHITE - EXTEND ROOM (FORWARD)
 - B) BLACK - SWITCHED BATTERY EXTEND
 - C) GREEN - RETRACT ROOM (REVERSE)
 - D) ORANGE - SWITCHED BATTERY RETRACT
 - E) BLUE - PUMP
 - F) RED - BATTERY

PINS NOT NOTED ARE UNUSED

			HWH			I-80 EXIT 267 SOUTH RT 1 MOSCOW, IOWA 52760		
			SCALE 1:3	DATE 16JUN11	DRAWN BY .			
			SYSTEM SCHEMATIC ELEC					
NO.	DATE	REVISION						
THE INFORMATION DISCLOSED ON THIS DRAWING IS CONFIDENTIAL AND MUST NOT BE DISCLOSED OR USED IN ANY MANNER WHICH WILL BE DETRIMENTAL TO THE HWH CORPORATION						DRAWING NUMBER MP90635 A/B		

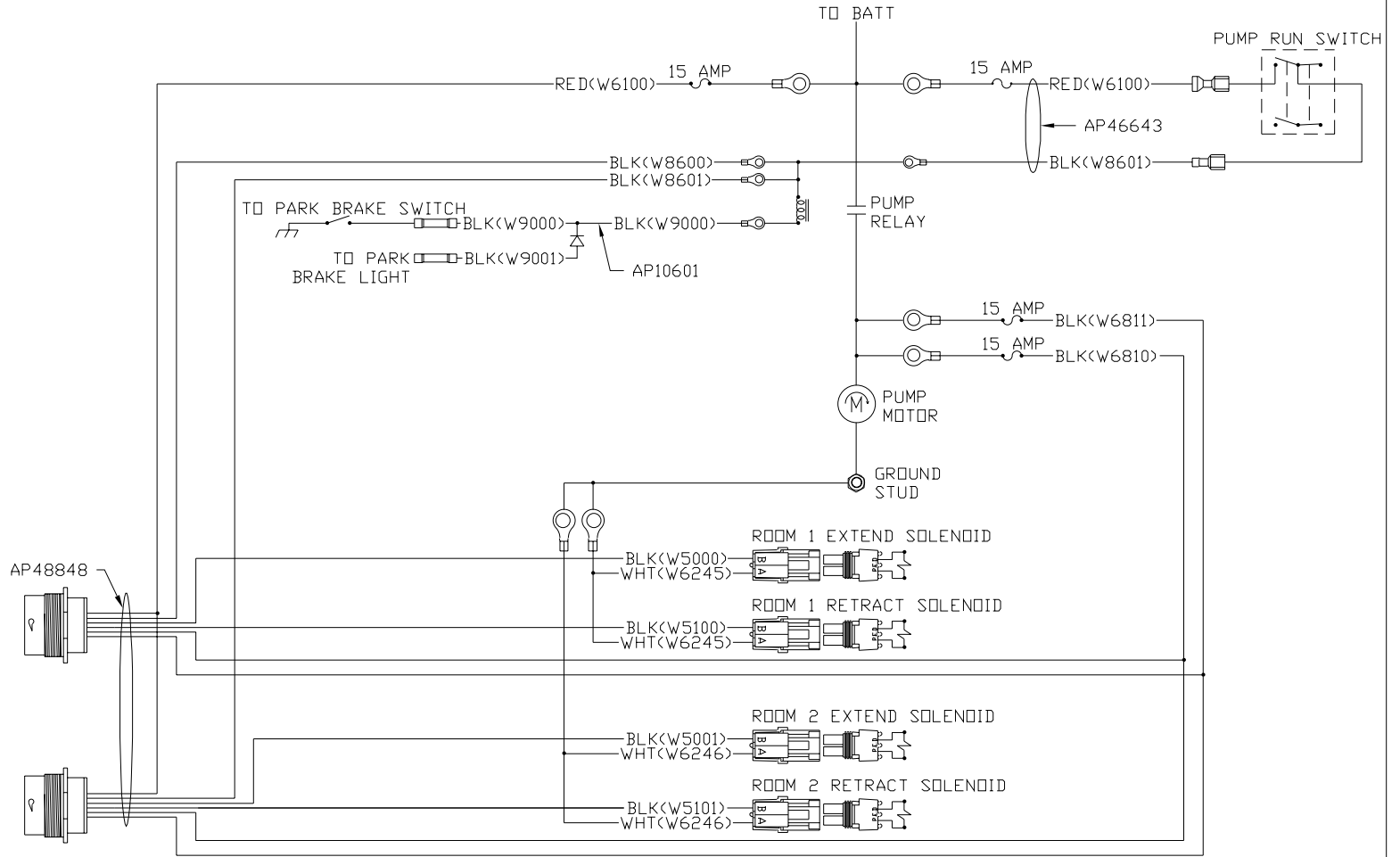

- PIN
- A) BLK(W5000) - EXTEND ROOM 1
 - B) BLK(W6810) - SW. BATTERY EXTEND
 - C) BLK(W5100) - RETRACT ROOM 1
 - D) BLK(W6811) - SW. BATTERY RETRACT
 - E) BLK(W8600) - PUMP
 - F) RED(W6100) - BATTERY

- PIN
- A) BLK(W5001) - EXTEND ROOM 2
 - B) BLK(W6810) - SW. BATTERY EXTEND
 - C) BLK(W5101) - RETRACT ROOM 2
 - D) BLK(W6811) - SW. BATTERY RETRACT
 - E) BLK(W8601) - PUMP
 - F) RED(W6100) - BATTERY

NOTE: INSTALLATION MUST CONFORM TO GOOD SHOP PRACTICES, SAE STANDARDS, RVIA STANDARDS, AND OTHER APPLICABLE STANDARDS.