

AP42581
FRONT ACTIVE AIR INPUT/OUTPUT MODULE

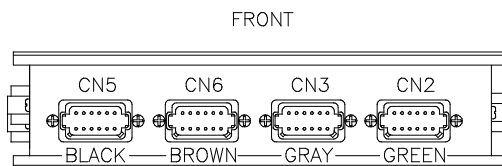
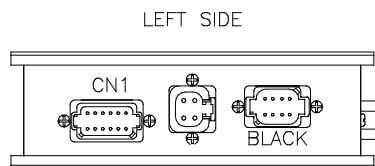

AP38815 CN1 (BROWN)

- PIN
- 1 BLK(W1500) LEFT FRONT RAISE
 - 2 BLK(W1600) LEFT FRONT LOWER
 - 3 BLK(W2500) RIGHT FRONT RAISE
 - 4 BLK(W2600) RIGHT FRONT LOWER
 - 5 BLK(W9700) COMPRESSOR
 - 6 N/C
 - 7 N/C
 - 8 N/C
 - 9 N/C
 - 10 N/C
 - 11 WHT(W6254) GROUND
 - 12 N/C

AP38815 (GRAY)

- PIN
- 1 RED(W6800) SW BATT
 - 2 RED(W6800) SW BATT
 - 3 GRN(W6230) GND
 - 4 GRN(W6230) GND

AP38815 RIGHT SIDE (BLACK)

- PIN
- 1 N/C
 - 2 N/C
 - 3 RED(W6800) SW BATTERY
 - 4 GRN(W6230) GROUND
 - 5 CAN SHIELD
 - 6 N/C
 - 7 GRN CAN LOW
 - 8 YEL CAN HI

AP38815 LEFT SIDE (BLACK)

- PIN
- 1 WHT(W7696) SYSTEM WAKE UP
 - 2 N/C
 - 3 RED(W6800) SW BATTERY
 - 4 GRN(W6230) GROUND
 - 5 CAN SHIELD
 - 6 N/C
 - 7 GRN CAN LOW
 - 8 YEL CAN HI

AP38815 CN5 (BLACK)

- PIN
- 1 BLK(W5703) ROOM 1 ROOM IN
 - 2 BLK(W5701) ROOM 1 ROOM OUT
 - 3 BLK(W5651) ROOM 1 VACUUM SENSOR
 - 4 N/C
 - 5 N/C
 - 6 WHT(W7501) EXTEND
 - 7 WHT(W7502) RETRACT
 - 8 N/C
 - 9 N/C
 - 10 N/C
 - 11 N/C
 - 12 N/C

AP38815 CN6 (BROWN)

- PIN
- 1 BLK(W6800) SW. +12V
 - 2 N/C
 - 3 N/C
 - 4 BLK(W7510) READY TO OPERATE
 - 5 BLK(W7530) PUMP
 - 6 WHT(W6236) GROUND
 - 7 BLK(W6805) SW BATTERY
 - 8 BLK(W7696) SYSTEM WAKE UP
 - 9 N/C
 - 10 N/C
 - 11 N/C
 - 12 N/C

AP38815 CN3 (GRAY)

- PIN
- 1 BLK(W1100) RIDE HEIGHT LOW
 - 2 BLK(W1101) RIDE HEIGHT MEDIUM
 - 3 BLK(W1102) RIDE HEIGHT HIGH
 - 4 BLK(W1103) ENCODE A
 - 5 BLK(W1104) ENCODE B
 - 6 N/C
 - 7 N/C
 - 8 BLK(W7400) STEERING A
 - 9 BLK(W7401) STEERING B
 - 10 N/C
 - 11 N/C
 - 12 N/C

AP38815 CN2 (GREEN)

- PIN
- 1 RED(W6120) SW. BATT
 - 2 BLK(W6900) +5V OUTPUT
 - 3 BLK(W6901) +5V OUTPUT
 - 4 N/C
 - 5 N/C
 - 6 WHT(W6235) GROUND
 - 7 RED(W6121) SW. BATT
 - 8 N/C
 - 9 N/C
 - 10 N/C
 - 11 BLK(W2220) RIGHT FRONT TRANSDUCER
 - 12 BLK(W1220) LEFT FRONT TRANSDUCER

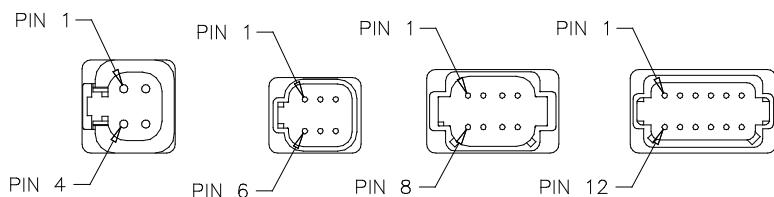

NOTE: DEUTSCH PIN NUMBERS TYPICAL UNLESS OTHERWISE NOTED

NOTE: INSTALLATION MUST CONFORM TO GOOD SHOP PRACTICES, SAE STANDARDS, RVIA STANDARDS, AND OTHER APPLICABLE STANDARDS.

		HWH		I-80 EXIT 267 SOUTH RT 1 MOSCOW, IOWA 52760	
		SCALE 1:3	DATE 06FEB13	DRAWN BY .	
		SYSTEM SCHEMATIC ELEC			
NO.	DATE				
		THE INFORMATION DISCLOSED ON THIS DRAWING IS CONFIDENTIAL AND MUST NOT BE DISCLOSED OR USED IN ANY MANNER WHICH WILL BE DETRIMENTAL TO THE HWH CORPORATION			
		DRAWING NUMBER MP90847 A/Q			

AP51403
CENTRAL CONTROL
MODULES

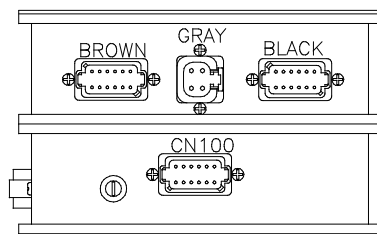
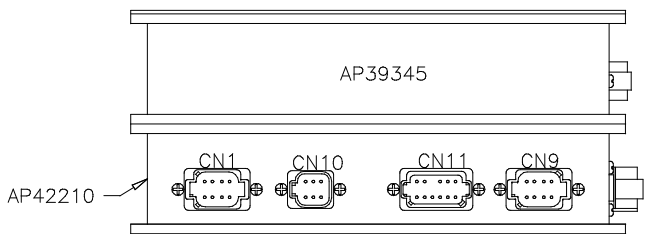

110 NEUTRAL HOLD ENABLED
220 NEUTRAL HOLD DISABLED

AP39345 (BROWN)

PIN	FUNCTION
1	BLK(W5050) CYLINDER EXTEND 1
2	BLK(W5150) CYLINDER RETRACT 1
3	BLK(W5600) AIR SEAL ROOM 1
4	BLK(W5650) VACUUM ROOM 1
5	N/C
6	N/C
7	N/C
8	N/C
9	BLK(W5054) CYLINDER EXTEND GEN
10	BLK(W5154) CYLINDER RETRACT GEN
11	WHT(W6230) GROUND
12	N/C

AP39345 (BLACK)

PIN	FUNCTION
1	BLK(W5051) CYLINDER EXTEND 2
2	BLK(W5151) CYLINDER RETRACT 2
3	BLK(W5601) AIR SEAL ROOM 2
4	BLK(W5651) VACUUM ROOM 2
5	N/C
6	N/C
7	N/C
8	N/C
9	N/C
10	N/C
11	WHT(W6230) GROUND
12	N/C

AP42210 CN100(GRAY)

PIN	FUNCTION
1	BLK(W5000) GEN SLIDE EXTEND
2	N/C
3	N/C
4	N/C
5	N/C
6	WHT(W6230) GROUND
7	N/C
8	N/C
9	N/C
10	N/C
11	N/C
12	BLK(W5100) GEN SLIDE RETRACT

AP39345 (GRAY)

PIN	FUNCTION
1	RED(W6800) SW BATT
2	RED(W6800) SW BATT
3	GRN(W6230) GROUND
4	GRN(W6230) GROUND

AP42210 CN1(BLACK)

PIN	FUNCTION
1	WHT(W7696) SYSTEM WAKE UP
2	N/C
3	RED(W6800) SW BATT
4	GRN(W6230) GND
5	CAN SHIELD
6	N/C
7	GRN CAN LOW
8	YEL CAN HI

AP42210 CN10(GRAY)

PIN	FUNCTION
1	BLK(W7599) SWITCH LIGHT CONTROL
2	RED(W6100) RESET OUT
3	BLK(W7550) RESET IN
4	RED(W6121) WARN LIGHT SUPPLY
5	WHT(W6230) SWITCH LIGHT SUPPLY
6	BLK(W7699) WARN LIGHT/BUZZER CONTROL

AP42210 CN11(GRAY)

PIN	FUNCTION
1	RED(W6110) IGNITION
2	N/C
3	N/C
4	N/C
5	RED(W6120) IGNITION
6	RED(W6100) HOUSE BATTERY
7	GRN(W6230) GROUND
8	WHT(W9961) NEUTRAL HOLD
9	WHT(W9955) NEUTRAL HOLD
10	N/C
11	WHT(W9000) PARK BRAKE SWITCH
12	RED(W6101) HOUSE BATTERY

AP42210 CN9(GREEN)

PIN	FUNCTION
1	BLK(W8500) MASTER RELAY CONTROL
2	BLK(W8100) SYSTEM PSW.
3	N/C
4	BLK(W8600) PUMP RELAY CONTROL
5	BLK(W9900) SPEED SWITCH
6	BLK(W9901) PUMP MONITOR
7	N/C
8	N/C

AP50486
REAR ACTIVE AIR INPUT/OUTPUT MODULE

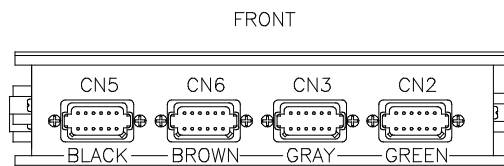
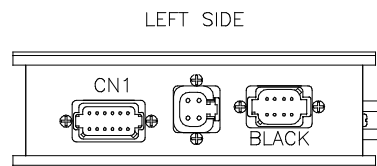

AP43341 CN1 BROWN
PIN

1	BLK(W4500)	LR RAISE
2	BLK(W4600)	LR LOWER
3	BLK(W4550)	LR HIGH VOLUME RAISE
4	N/C	
5	BLK(W3500)	RR RAISE
6	BLK(W3600)	RR LOWER
7	BLK(W3550)	RR HIGH VOLUME RAISE
8	N/C	
9	N/C	
10	N/C	
11	WHT(W6258)	GROUND
12	N/C	

AP43341 (GRAY)
PIN

1	RED (W6800)	SW BATT
2	RED (W6800)	SW BATT
3	GRN (W6230)	GND
4	GRN (W6230)	GND

AP43341 BLACK (LEFT SIDE)
PIN

1	WHT(W7696)	SYSTEM WAKE UP
2	N/C	
3	RED(W6800)	SW BATTERY
4	GRN(W6230)	GROUND
5	CAN SHIELD	
6	N/C	
7	GRN CAN LOW	
8	YEL CAN HI	

AP43341 BLACK (RIGHT SIDE)
PIN

1	N/C	
2	N/C	
3	N/C	
4	N/C	
5	N/C	
6	N/C	
7	BLACK 120 ?	RESISTOR
8	BLACK 120 ?	RESISTOR

AP43341 CN5(BLACK)
PIN

1	BLK(W3100)	RR RIDE HEIGHT LOW
2	BLK(W3101)	RR RIDE HEIGHT MEDIUM
3	BLK(W3102)	RR RIDE HEIGHT HIGH
4	BLK(W3103)	RR ENCODE A
5	BLK(W3104)	RR ENCODE B
6	N/C	
7	N/C	
8	N/C	
9	N/C	
10	N/C	
11	N/C	
12	N/C	

AP43341 CN6(BROWN)
PIN

1	RED(W6121)	SW. BATT.
2	BLK(W6908)	+5V OUTPUT
3	BLK(W6909)	+5V OUTPUT
4	N/C	
5	N/C	
6	WHT(W6232)	GROUND
7	RED(W6805)	SW BATTERY
8	N/C	
9	N/C	
10	BLK(W3225)	SYSTEM TRANSDUCER
11	WHT(W6232)	GROUND
12	BLK(W3220)	RR TRANSDUCER

AP43341 CN3(GRAY)
PIN

1	BLK(W4100)	LR RIDE HEIGHT LOW
2	BLK(W4101)	LR RIDE HEIGHT MEDIUM
3	BLK(W4102)	LR RIDE HEIGHT HIGH
4	BLK(W4103)	LR ENCODE A
5	BLK(W4104)	LR ENCODE B
6	BLK(W7501)	EXTEND (ROOM 2 AND 3)
7	BLK(W7502)	RETRACT (ROOM 2 AND 3)
8	N/C	
9	N/C	
10	BLK(W5703)	ROOM 2 ROOM IN
11	BLK(W5701)	ROOM 2 ROOM OUT
12	BLK(W5651)	ROOM 2 VACUUM SENSOR

AP43341 CN2(GREEN)
PIN

1	RED(W6120)	SW. BATT
2	BLK(W6912)	+5V OUTPUT
3	N/C	
4	BLK(W7510)	READY TO OPERATE
5	BLK(W7530)	PUMP
6	WHT(W6233)	GROUND
7	BLK(W6800)	SW. +12V
8	WHT(W7696)	SYSTEM WAKE UP
9	N/C	
10	N/C	
11	WHT(W6233)	GROUND
12	BLK(W4220)	LR TRANSDUCER

NOTE: INSTALLATION MUST CONFORM TO GOOD SHOP PRACTICES, SAE STANDARDS, RVIA STANDARDS, AND OTHER APPLICABLE STANDARDS.

MP90847 C
06FEB13

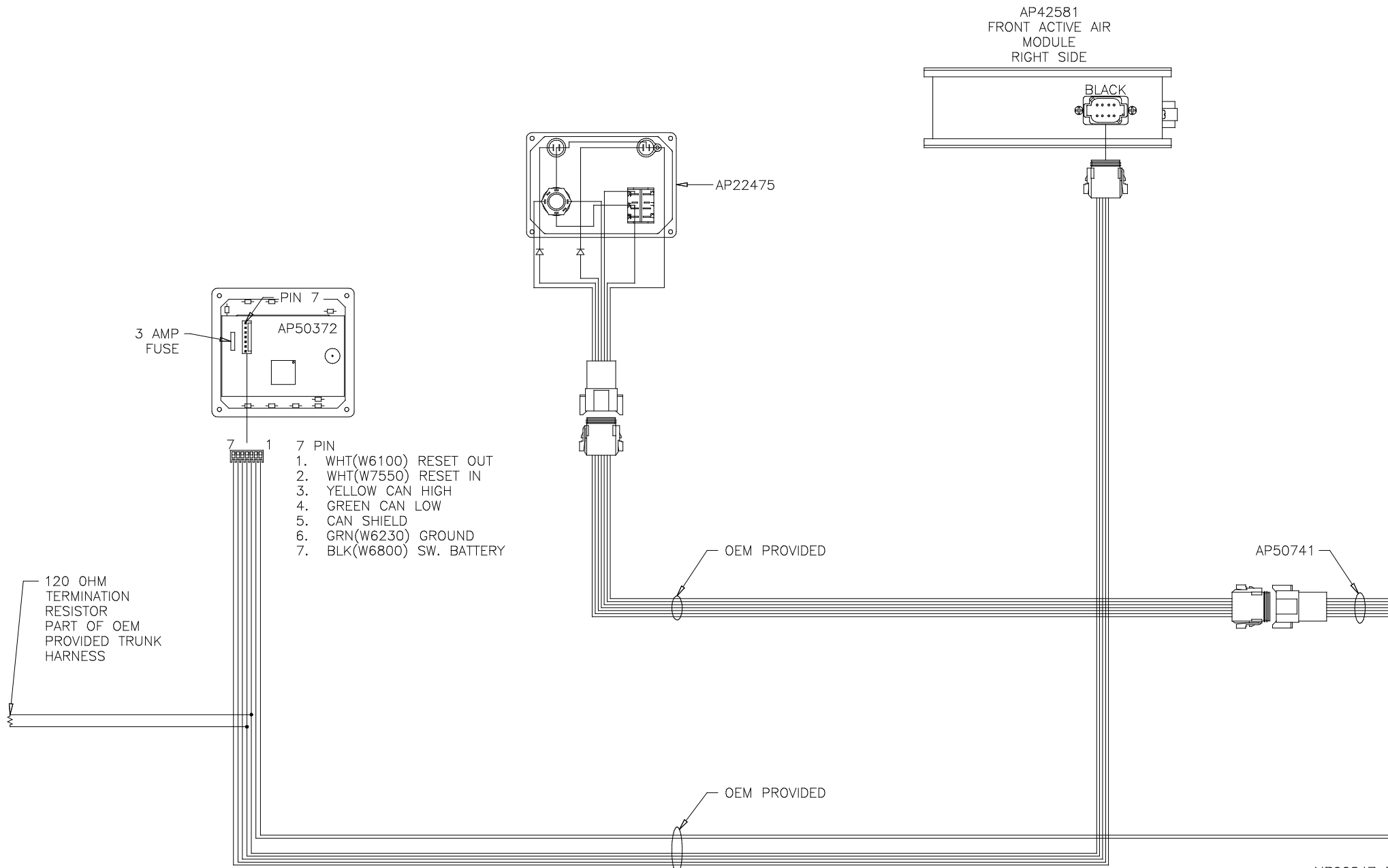

NOTE: INSTALLATION MUST CONFORM TO GOOD SHOP PRACTICES, SAE STANDARDS, RVIA STANDARDS, AND OTHER APPLICABLE STANDARDS.

AP42581
FRONT ACTIVE AIR MODULE
FRONT SIDE

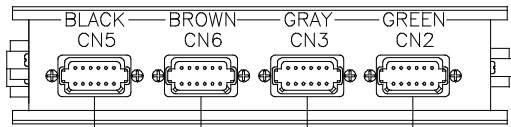

AP50741

BLK(W1220)
BLK(W6900)
BLK(W2220)

WHT(W6235)
BLK(W6901)

- PIN
1. BLK(W7400) STEERING A
 2. BLK(W7401) STEERING B
 3. RED(W6121) SW. BATT
 4. RED(W6120) SW BATT
 5. WHT(W6235) GROUND
 6. WHT(W6235) GROUND
 7. N/C
 8. N/C

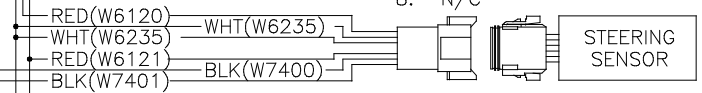

STEERING
SENSOR

RED(W6121)
BLK(W1100)
BLK(W1102)
BLK(W1104)

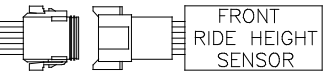

FRONT
RIDE HEIGHT
SENSOR

- PIN
1. WHT(W6235) GROUND
 2. BLK(W1101) RIDE HEIGHT MED
 3. BLK(W1102) RIDE HEIGHT HIGH
 4. RED(W6121) SW. BATT
 5. BLK(W1100) RIDE HEIGHT LOW
 6. BLK(W1103) ENCODE A
 7. BLK(W1104) ENCODE B
 8. N/C

WHT(W6236)

BLK(W5651)

VACUUM PRESSURE SENSE ROOM 1

(ROOM 1)

BLK(W5701)

BLK(W6800)

ROOM
OUT

WHT(W6236)

BLK(W5703)

BLK(W6800)

ROOM
IN

WHT(W6236)

OEM PROVIDED

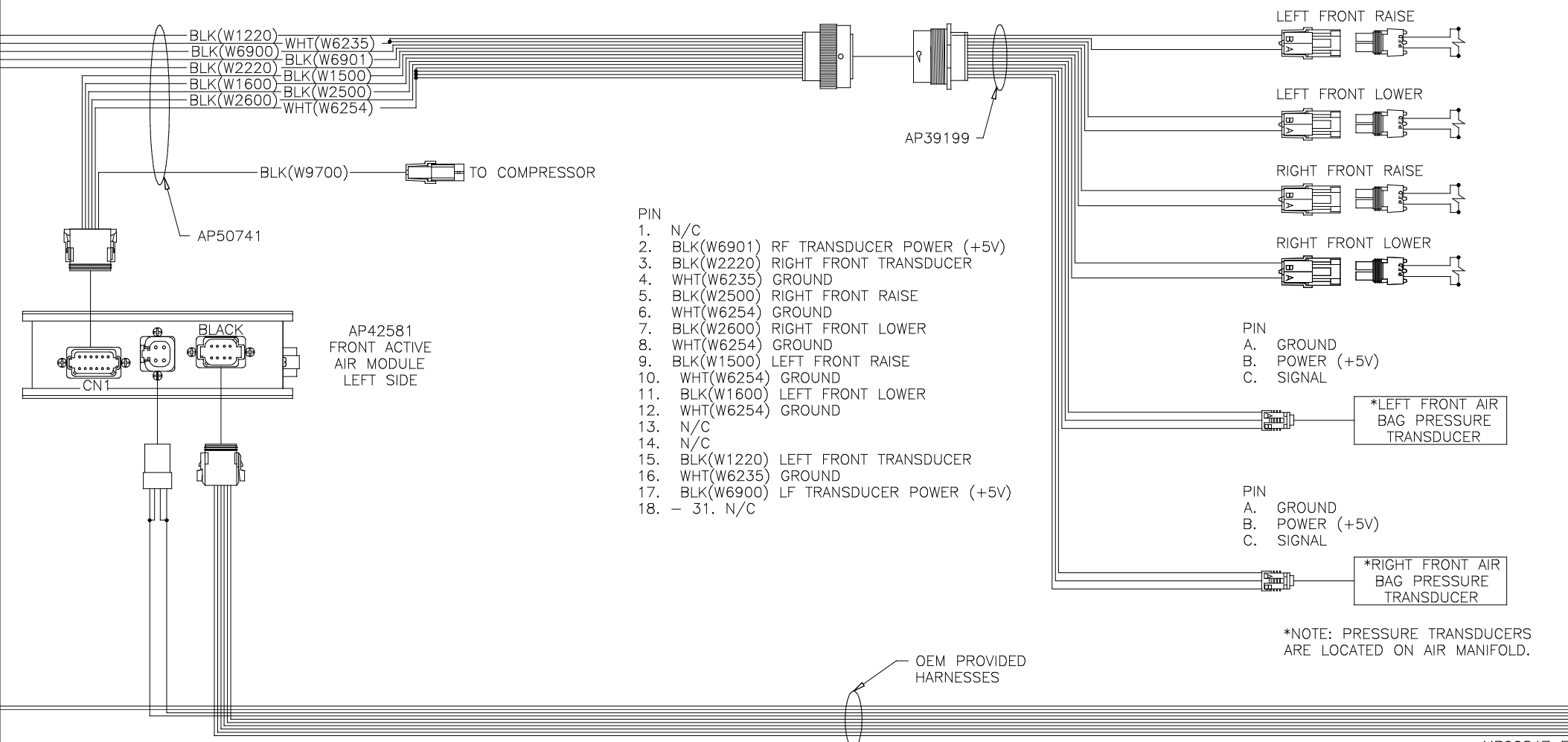

NOTE: INSTALLATION MUST CONFORM TO GOOD SHOP PRACTICES, SAE STANDARDS, RVIA STANDARDS, AND OTHER APPLICABLE STANDARDS.

TO IGNITION — RED(W6110)
 TO IGNITION — RED(W6120)
 TO HOUSE BATTERY — RED(W6101)
 TO GROUND — GRN(W6230)
 TO PARK BRAKE — WHT(W9000)
 TO HOUSE BATTERY — RED(W6100)
 TO NEUTRAL HOLD — WHT(W9961)
 TO NEUTRAL HOLD — WHT(W9955)
 OEM PROVIDED

AP51403
 CENTRAL CONTROL MODULE
 FRONT VIEW

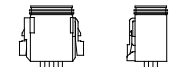
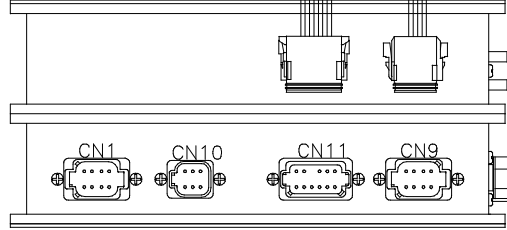

WHT(W7699) — MASTER WARNING LIGHT
 WHT(W6121) —

3000 LB PRESS. SW.
 BLK(W8100) —
 BLK(W9900) — TO SPEED SWITCH

HOUSE BATTERY
 BLK(W8500) —
 WHT(W6231) — MASTER RELAY
 BLK(W8600) —
 WHT(W6231) — PUMP RELAY
 BLK(W9901) —



GROUND STUD

AP24826

110 NEUTRAL HOLD ENABLED
 220 NEUTRAL HOLD DISABLED

GEN SLIDE — P20516

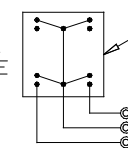

BLK(W5000)
 WHT(W6230)
 BLK(W5100)

20 AMP
 20 AMP
 30 AMP

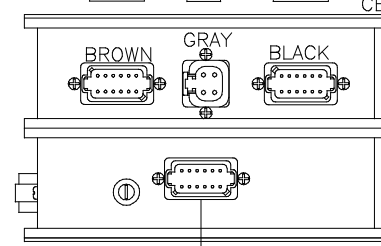

AP42906

AP42884

AP51403
 CENTRAL CONTROL MODULE
 RIGHT VIEW

GROUND STUD

AP37839

OEM PROVIDED HARNESSSES

NOTE: INSTALLATION MUST CONFORM TO GOOD SHOP PRACTICES, SAE STANDARDS, RVIA STANDARDS, AND OTHER APPLICABLE STANDARDS.

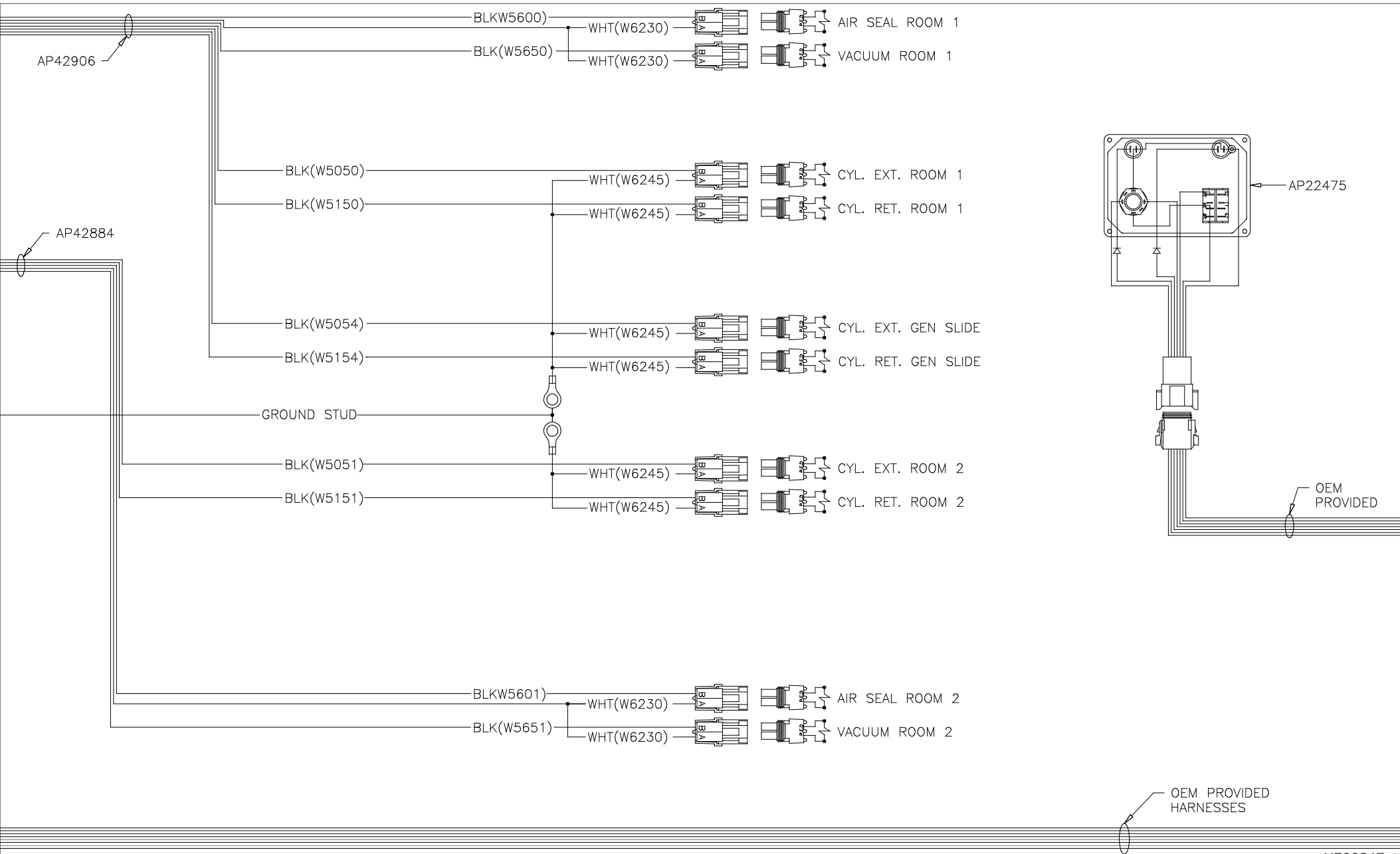

NOTE: INSTALLATION MUST CONFORM TO GOOD SHOP PRACTICES, SAE STANDARDS, RVIA STANDARDS, AND OTHER APPLICABLE STANDARDS.

MP90847 H
06FEB13

AP50486
REAR ACTIVE AIR MODULE
FRONT SIDE

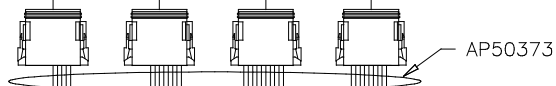
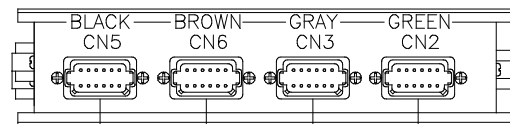

- BLK(W4220) — WHT(W6233)
- BLK(W6912) — BLK(W6909)
- BLK(W3225) — BLK(W6908)
- WHT(W6232) — BLK(W3220)

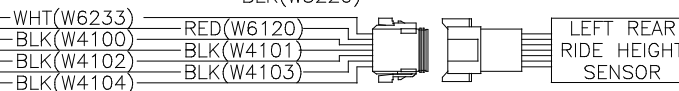

- PIN
- | | |
|-----------------------------------|---------------------------------|
| 1. WHT(W6233) GROUND | 5. BLK(4100) LR RIDE HEIGHT LOW |
| 2. BLK(W4101) LR RIDE HEIGHT MED | 6. BLK(4103) LR ENCODE A |
| 3. BLK(W4102) LR RIDE HEIGHT HIGH | 7. BLK(4104) LR ENCODE B |
| 4. RED(W6120) SW. BATT | 8. N/C |

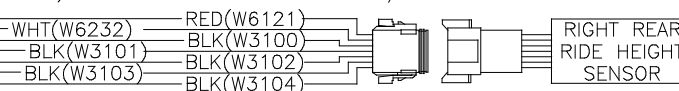

- PIN
- | | |
|----------------------------------|----------------------------------|
| 1. WHT(W6232) GROUND | 5. RED(W3100) RR RIDE HEIGHT LOW |
| 2. BLK(W3101) RR RIDE HEIGHT MED | 6. BLK(W3103) RR ENCODE A |
| 3. BLK(W3102) RR RIDE HEIGHT HI | 7. BLK(W3104) RR ENCODE B |
| 4. RED(W6121) SW. BATT | 8. N/C |

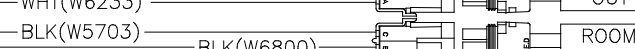
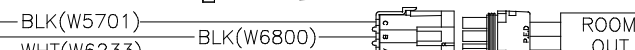
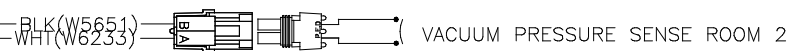

- OEM PROVIDED
- PIN
- | |
|-------------------------------|
| 1 N/C |
| 2 BLK(W7510) READY TO OPERATE |
| 3 BLK(W7530) PUMP |
| 4 WHT(W7501) EXTEND |
| 5 WHT(W7502) RETRACT |
| 6 BLK(W6805) SW BATTERY |
| 7 BLK(W7631) SYS WAKE UP |
| 8 WHT(W6230) GROUND |

OEM PROVIDED HARNESSSES

NOTE: INSTALLATION MUST CONFORM TO GOOD SHOP PRACTICES, SAE STANDARDS, RVIA STANDARDS, AND OTHER APPLICABLE STANDARDS.

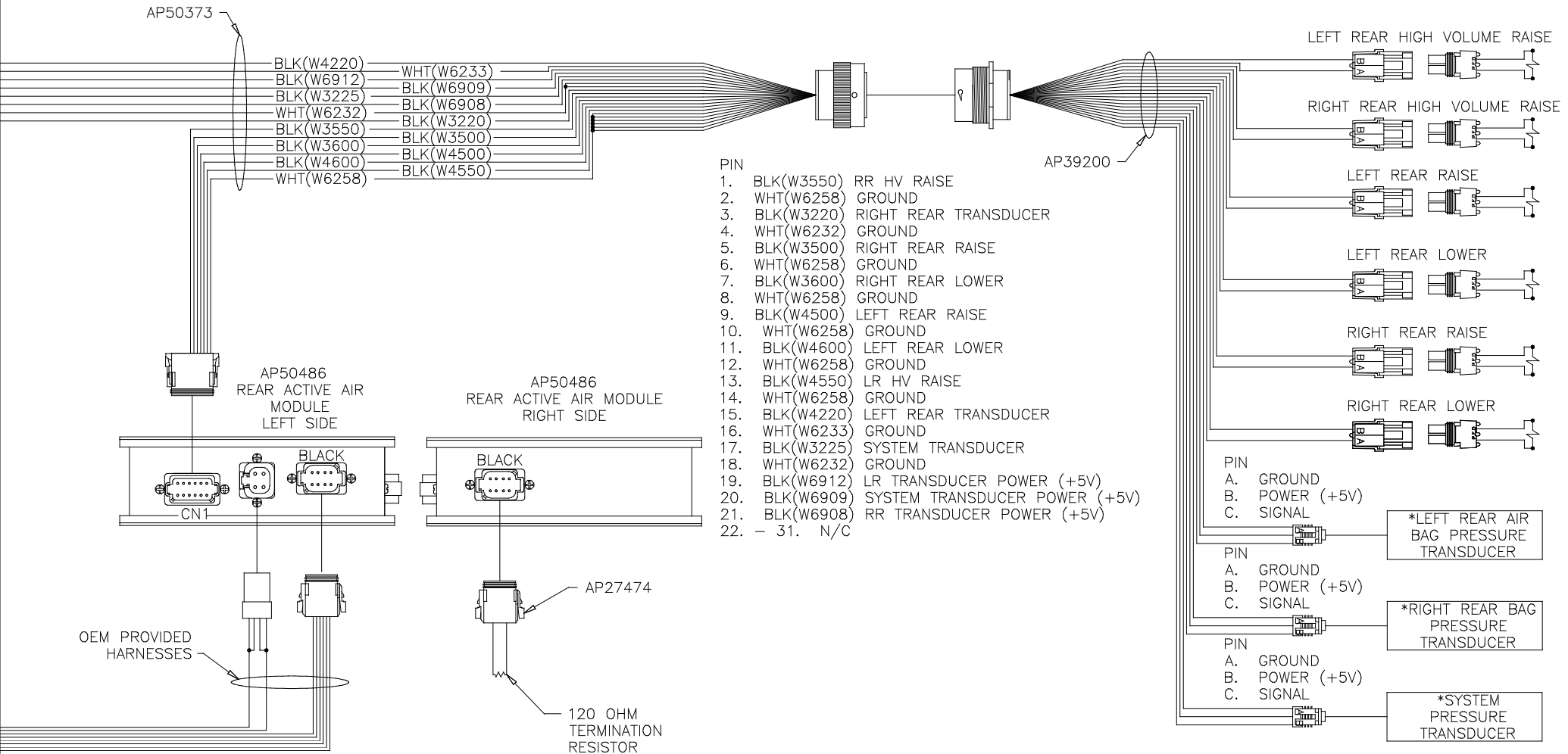

NOTE: INSTALLATION MUST CONFORM TO GOOD SHOP PRACTICES, SAE STANDARDS, RVIA STANDARDS, AND OTHER APPLICABLE STANDARDS.

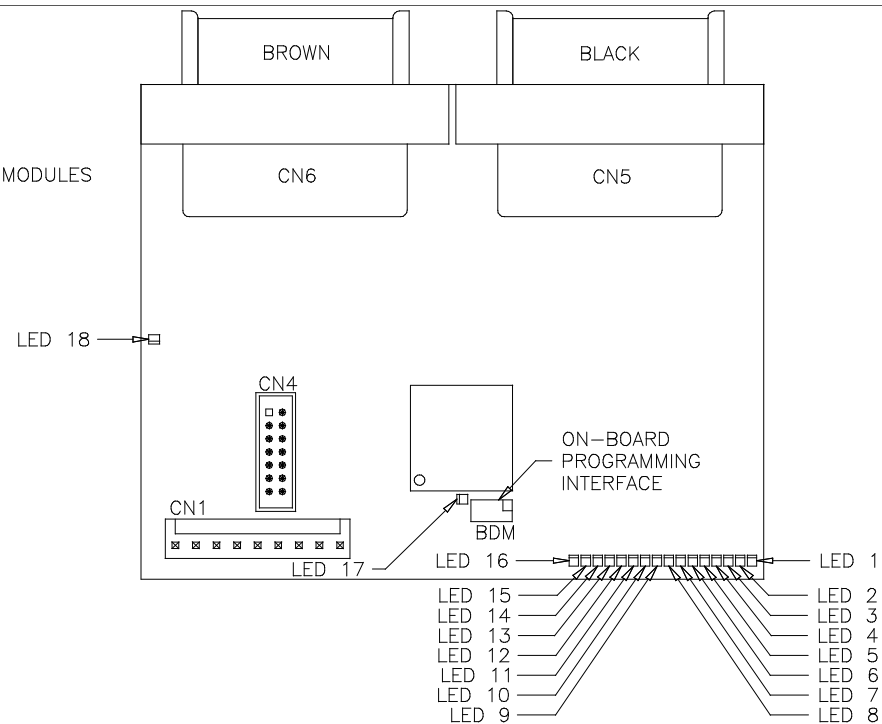
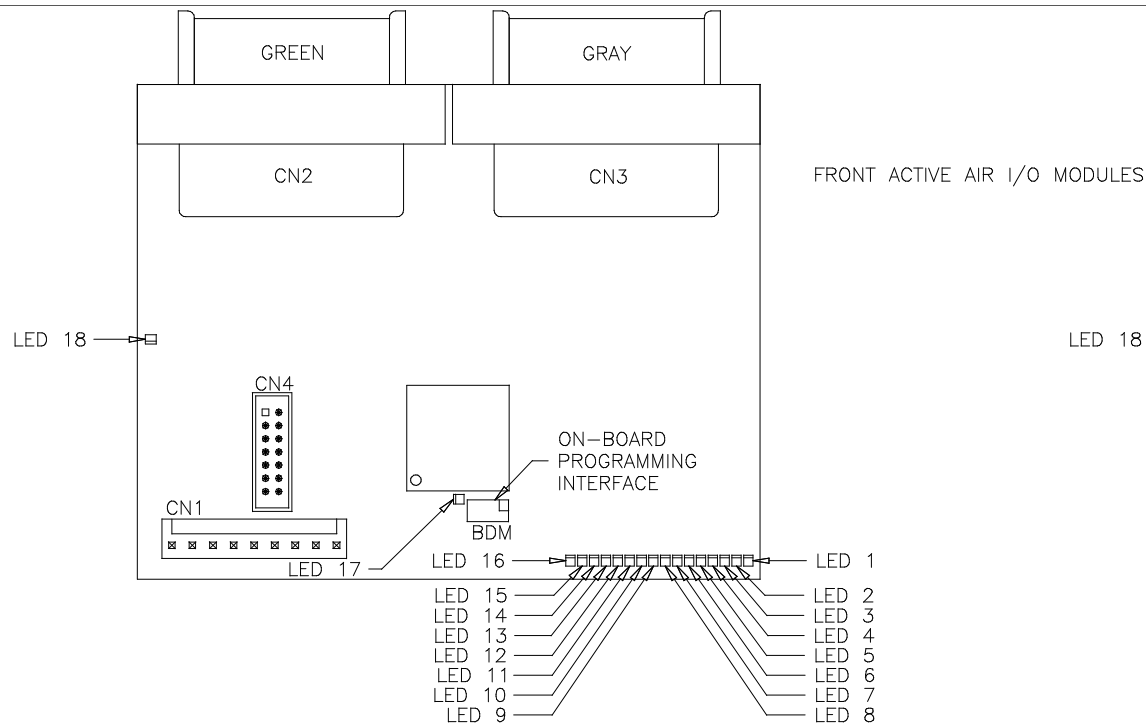

LED #	CONNECTOR	COLOR	DESCRIPTION
LED 1	CN3 PIN 1	RED	FRONT RIDE HEIGHT LOW
LED 2	CN3 PIN 2	GREEN	FRONT RIDE HEIGHT MED
LED 3	CN3 PIN 3	YELLOW	FRONT RIDE HEIGHT HIGH
LED 4	CN3 PIN 4	RED	ENCODE A
LED 5	CN3 PIN 5	GREEN	ENCODE B
LED 6	NOT USED	YELLOW	NOT USED
LED 7	NOT USED	RED	NOT USED
LED 8	CN3 PIN 8	GREEN	STEERING A
LED 9	CN3 PIN 9	YELLOW	STEERING B
LED 10	NOT USED	RED	NOT USED
LED 11	NOT USED	GREEN	NOT USED
LED 12	NOT USED	YELLOW	NOT USED
LED 13	NOT USED	RED	NOT USED
LED 14	NOT USED	GREEN	NOT USED
LED 15	NOT USED	YELLOW	NOT USED
LED 16	NOT USED	RED	NOT USED
LED 17	NOT APPLICABLE	RED	LINK LIGHT
LED 18	NOT APPLICABLE	RED	POWER TO CAN MODULES

LED #	CONNECTOR	COLOR	DESCRIPTION
LED 1	CN5 PIN 1	RED	ROOM 1 ROOM IN
LED 2	CN5 PIN 2	GREEN	ROOM 1 ROOM OUT
LED 3	CN5 PIN 3	YELLOW	ROOM 1 VACUUM SENSOR
LED 4	NOT USED	RED	NOT USED
LED 5	NOT USED	GREEN	NOT USED
LED 6	CN5 PIN 6	YELLOW	EXTEND
LED 7	CN5 PIN 7	RED	RETRACT
LED 8	NOT USED	GREEN	NOT USED
LED 9	NOT USED	YELLOW	NOT USED
LED 10	NOT USED	RED	NOT USED
LED 11	NOT USED	GREEN	NOT USED
LED 12	NOT USED	YELLOW	NOT USED
LED 13	NOT USED	RED	NOT USED
LED 14	NOT USED	GREEN	NOT USED
LED 15	NOT USED	YELLOW	NOT USED
LED 16	CN6 PIN 8	RED	SYSTEM WAKE UP
LED 17	NOT APPLICABLE	RED	LINK LIGHT
LED 18	NOT APPLICABLE	RED	POWER TO CAN MODULES

NOTE: INSTALLATION MUST CONFORM TO GOOD SHOP PRACTICES, SAE STANDARDS, RVIA STANDARDS, AND OTHER APPLICABLE STANDARDS.

MP90847 K
06FEB13

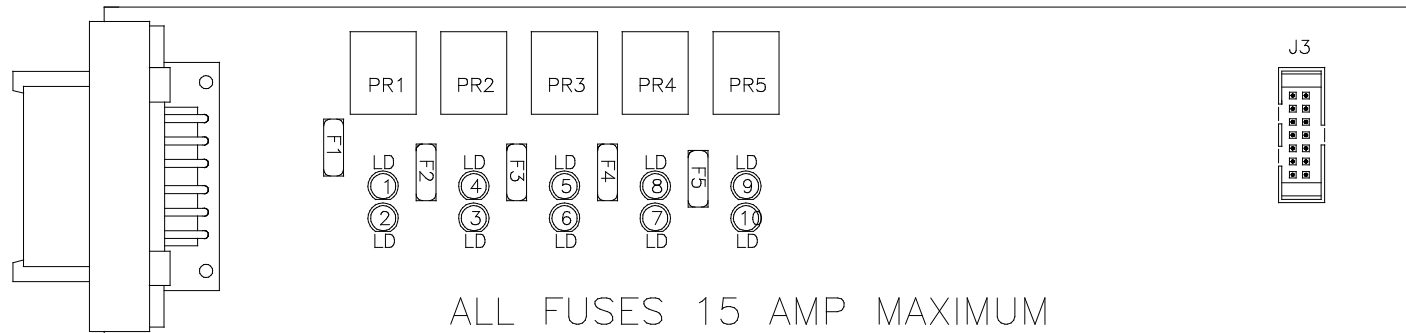

FRONT AIR
LED LAYOUT

LED #	COLOR	FUSE #	OUTPUT	RELAY #	DESCRIPTION
LED1	YELLOW	---	---	PR1	LEFT FRONT RAISE (COIL)
LED2	RED	FUSE 1	PIN 1	PR1	LEFT FRONT RAISE (CONTACT)
LED3	RED	FUSE 2	PIN 2	PR2	LEFT FRONT LOWER (CONTACT)
LED4	YELLOW	---	---	PR2	LEFT FRONT LOWER (COIL)
LED5	YELLOW	---	---	PR3	RIGHT FRONT RAISE (COIL)
LED6	RED	FUSE 3	PIN 3	PR3	RIGHT FRONT RAISE (CONTACT)
LED7	RED	FUSE 4	PIN 4	PR4	RIGHT FRONT LOWER (CONTACT)
LED8	YELLOW	---	---	PR4	RIGHT FRONT LOWER (COIL)
LED9	YELLOW	---	---	PR5	COMPRESSOR (COIL)
LED10	RED	FUSE 5	PIN 5	PR5	COMPRESSOR (CONTACT)

GENERATOR SLIDE/STEP COVER
REED SWITCH
LAYOUT

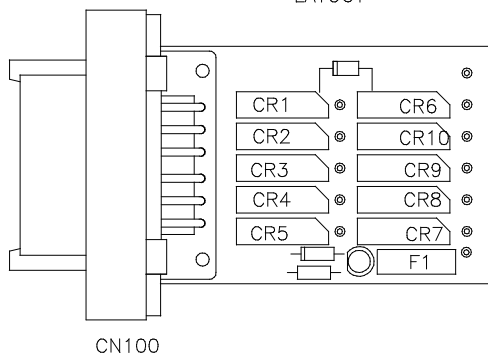

CN100

CONNECTOR	REED SWITCH	DESCRIPTION
CN 100 PIN 1	CR1	GEN SLIDE EXTEND
CN 100 PIN 2	CR2	NOT USED
CN 100 PIN 3	CR3	NOT USED
CN 100 PIN 4	CR4	NOT USED
CN 100 PIN 5	CR5	NOT USED
CN 100 PIN 6	---	GROUND
CN 100 PIN 7	---	NOT USED
CN 100 PIN 8	CR7	NOT USED
CN 100 PIN 9	CR8	NOT USED
CN 100 PIN 10	CR9	NOT USED
CN 100 PIN 11	CR10	NOT USED
CN 100 PIN 12	CR6	GEN SLIDE RETRACT

NOTE: INSTALLATION MUST CONFORM TO GOOD SHOP PRACTICES, SAE STANDARDS, RVIA STANDARDS, AND OTHER APPLICABLE STANDARDS.

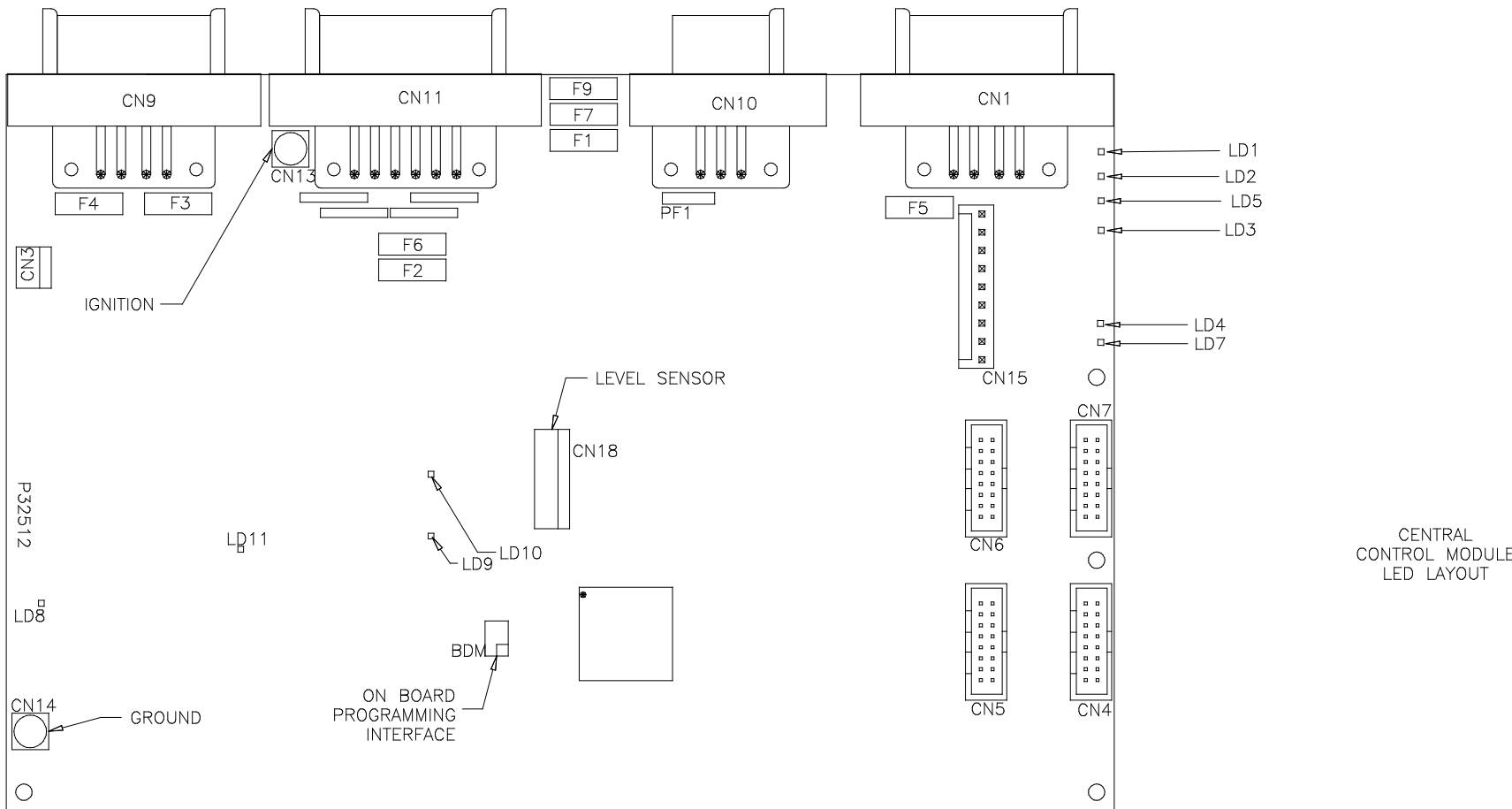

CENTRAL CONTROL MODULE LED LAYOUT

LED #	CONNECTOR	COLOR	DESCRIPTION
LED 1	CN 9 PIN 1	RED	MASTER RELAY
LED 2	CN 9 PIN 4	RED	PUMP RELAY
LED 3	CN 1 PIN 3	RED	SW 12V
LED 4	CN 11 PIN 12	RED	ENGINE BATT
LED 5	CN 9 PIN 5	RED	SPEED SWITCH
LED 7	CN 1 PIN 7 & 8	RED	LINK LIGHT
LED 8	CN 11 PIN 8 & 9	RED	NEUTRAL HOLD
LED 9	NOT USED	NOT USED	NOT USED
LED 10	CN9 PIN 2	RED	3000 LBS. PSW
LED 11	CN11 PIN 11	RED	PARK BRAKE

FUSE #	DESCRIPTION
PF1	RESET OUT
F7	ACCESSORY
F1	IGNITION
F2	HOUSE BATTERY
F3	MASTER RELAY
F4	PUMP RELAY
F5	SW. BATT TO CAN MODULES
F6	ENGINE BATTERY
F9	POWER TO CN100

NOTE: INSTALLATION MUST CONFORM TO GOOD SHOP PRACTICES, SAE STANDARDS, RVIA STANDARDS, AND OTHER APPLICABLE STANDARDS.

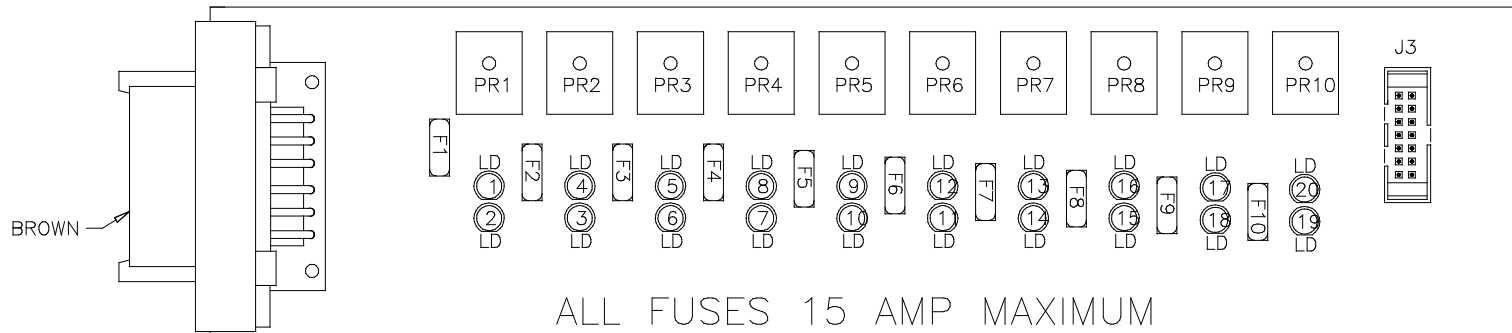

ROOM OUTPUTS
LED LAYOUT

LED #	COLOR	FUSE #	OUTPUT	RELAY #	DESCRIPTION
LED1	YELLOW	---	---	PR1	CYLINDER EXTEND 1 (COIL)
LED2	RED	FUSE 1	PIN 1	PR1	CYLINDER EXTEND 1 (CONTACT)
LED3	RED	FUSE 2	PIN 2	PR2	CYLINDER RETRACT 1 (CONTACT)
LED4	YELLOW	---	---	PR2	CYLINDER RETRACT 1 (COIL)
LED5	YELLOW	---	---	PR3	AIR SEAL ROOM 1 (COIL)
LED6	RED	FUSE 3	PIN 3	PR3	AIR SEAL ROOM 1 (CONTACT)
LED7	RED	FUSE 4	PIN 4	PR4	VACUUM ROOM 1 (CONTACT)
LED8	YELLOW	---	---	PR4	VACUUM ROOM 1 (COIL)
LED9	YELLOW	---	---	PR5	NOT USED
LED10	RED	FUSE 5	PIN 5	PR5	NOT USED
LED11	RED	FUSE 6	PIN 6	PR6	NOT USED
LED12	YELLOW	---	---	PR6	NOT USED
LED13	YELLOW	---	---	PR7	NOT USED
LED14	RED	FUSE 7	PIN 7	PR7	NOT USED
LED15	RED	FUSE 8	PIN 8	PR8	NOT USED
LED16	YELLOW	---	---	PR8	NOT USED
LED17	YELLOW	---	---	PR9	CYLINDER EXTEND GEN (COIL)
LED18	RED	FUSE 9	PIN 9	PR9	CYLINDER EXTEND GEN (CONTACT)
LED19	RED	FUSE 10	PIN 10	PR10	CYLINDER RETRACT GEN (CONTACT)
LED20	YELLOW	---	---	PR10	CYLINDER RETRACT GEN (COIL)

NOTE: INSTALLATION MUST CONFORM TO GOOD SHOP PRACTICES, SAE STANDARDS, RVIA STANDARDS, AND OTHER APPLICABLE STANDARDS.

MP90847 N
06FEB13

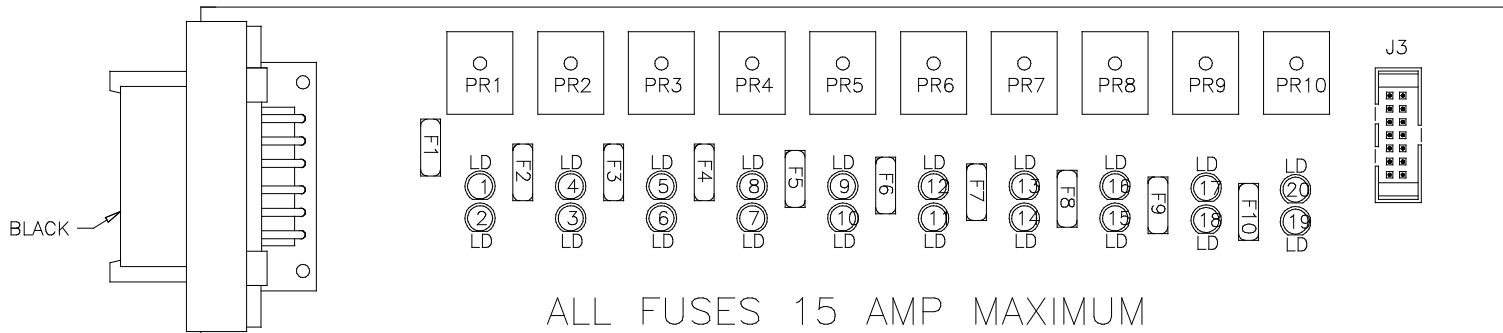

ROOM OUTPUTS
LED LAYOUT

LED #	COLOR	FUSE #	OUTPUT	RELAY #	DESCRIPTION
LED1	YELLOW	---	---	PR1	CYLINDER EXTEND 2 (COIL)
LED2	RED	FUSE 1	PIN 1	PR1	CYLINDER EXTEND 2 (CONTACT)
LED3	RED	FUSE 2	PIN 2	PR2	CYLINDER RETRACT 2 (CONTACT)
LED4	YELLOW	---	---	PR2	CYLINDER RETRACT 2 (COIL)
LED5	YELLOW	---	---	PR3	AIR SEAL ROOM 2 (COIL)
LED6	RED	FUSE 3	PIN 3	PR3	AIR SEAL ROOM 2 (CONTACT)
LED7	RED	FUSE 4	PIN 4	PR4	VACUUM ROOM 2 (CONTACT)
LED8	YELLOW	---	---	PR4	VACUUM ROOM 2 (COIL)
LED9	YELLOW	---	---	PR5	NOT USED
LED10	RED	FUSE 5	PIN 5	PR5	NOT USED
LED11	RED	FUSE 6	PIN 6	PR6	NOT USED
LED12	YELLOW	---	---	PR6	NOT USED
LED13	YELLOW	---	---	PR7	NOT USED
LED14	RED	FUSE 7	PIN 7	PR7	NOT USED
LED15	RED	FUSE 8	PIN 8	PR8	NOT USED
LED16	YELLOW	---	---	PR8	NOT USED
LED17	YELLOW	---	---	PR9	NOT USED
LED18	RED	FUSE 9	PIN 9	PR9	NOT USED
LED19	RED	FUSE 10	PIN 10	PR10	NOT USED
LED20	YELLOW	---	---	PR10	NOT USED

NOTE: INSTALLATION MUST CONFORM TO GOOD SHOP PRACTICES, SAE STANDARDS, RVIA STANDARDS, AND OTHER APPLICABLE STANDARDS.

MP90847 0
06FEB13

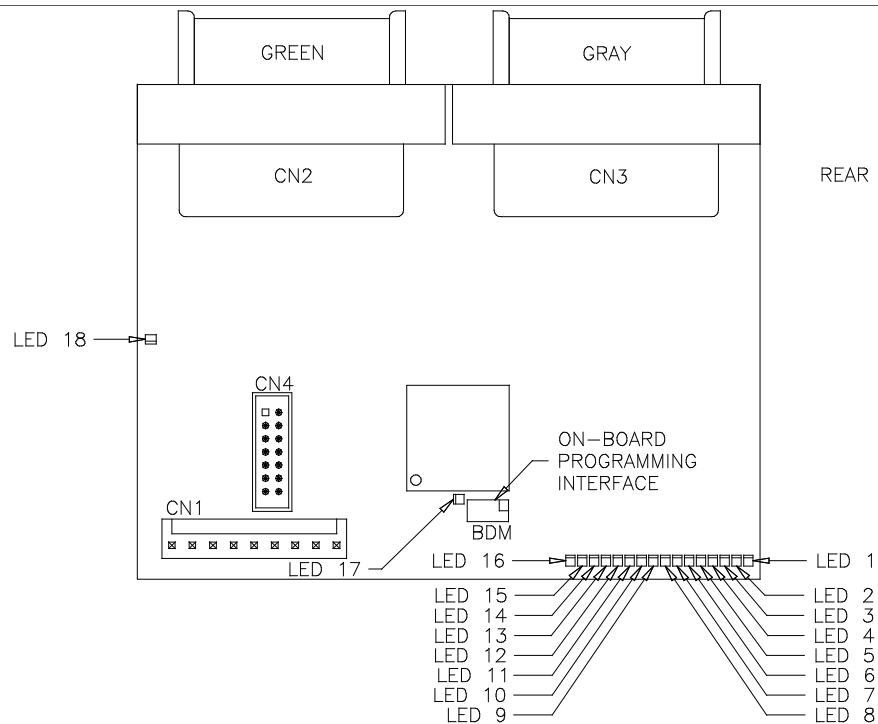

REAR ACTIVE AIR I/O MODULES

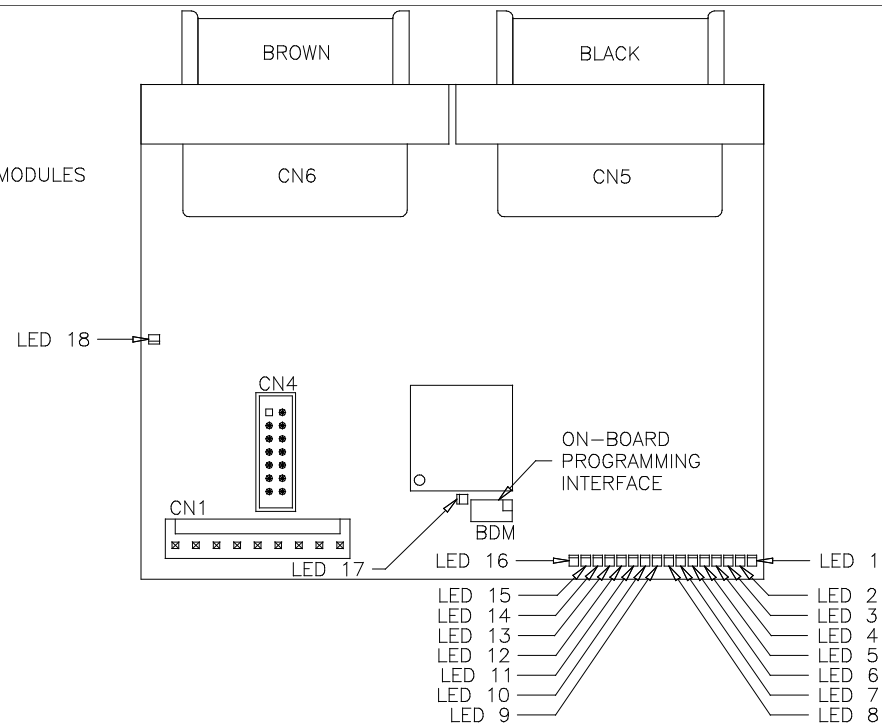

LED #	CONNECTOR	COLOR	DESCRIPTION
LED 1	CN3 PIN 1	RED	LR RIDE HEIGHT LOW
LED 2	CN3 PIN 2	GREEN	LR RIDE HEIGHT MED
LED 3	CN3 PIN 3	YELLOW	LR RIDE HEIGHT HIGH
LED 4	CN3 PIN 4	RED	LR ENCODE A
LED 5	CN3 PIN 5	GREEN	LR ENCODE B
LED 6	CN3 PIN 6	YELLOW	EXTEND
LED 7	CN3 PIN 7	RED	RETRACT
LED 8	NOT USED	GREEN	NOT USED
LED 9	NOT USED	YELLOW	NOT USED
LED 10	CN3 PIN 10	RED	ROOM 2 ROOM IN
LED 11	CN3 PIN 11	GREEN	ROOM 2 ROOM OUT
LED 12	CN3 PIN 12	YELLOW	ROOM 2 VACUUM SENSOR
LED 13	NOT USED	RED	NOT USED
LED 14	NOT USED	GREEN	NOT USED
LED 15	NOT USED	YELLOW	NOT USED
LED 16	CN2 PIN 8	RED	SYSTEM WAKE UP
LED 17	NOT APPLICABLE	RED	LINK LIGHT
LED 18	NOT APPLICABLE	RED	POWER TO CAN MODULES

LED #	CONNECTOR	COLOR	DESCRIPTION
LED 1	CN5 PIN 1	RED	RR RIDE HEIGHT LOW
LED 2	CN5 PIN 2	GREEN	RR RIDE HEIGHT MED
LED 3	CN5 PIN 3	YELLOW	RR RIDE HEIGHT HIGH
LED 4	CN5 PIN 4	RED	RR ENCODE A
LED 5	CN5 PIN 5	GREEN	RR ENCODE B
LED 6	NOT USED	YELLOW	NOT USED
LED 7	NOT USED	RED	NOT USED
LED 8	NOT USED	GREEN	NOT USED
LED 9	NOT USED	YELLOW	NOT USED
LED 10	NOT USED	RED	NOT USED
LED 11	NOT USED	GREEN	NOT USED
LED 12	NOT USED	YELLOW	NOT USED
LED 13	NOT USED	RED	NOT USED
LED 14	NOT USED	GREEN	NOT USED
LED 15	NOT USED	YELLOW	NOT USED
LED 16	NOT USED	RED	NOT USED
LED 17	NOT APPLICABLE	RED	LINK LIGHT
LED 18	NOT APPLICABLE	RED	POWER TO CAN MODULES

NOTE: INSTALLATION MUST CONFORM TO GOOD SHOP PRACTICES, SAE STANDARDS, RVIA STANDARDS, AND OTHER APPLICABLE STANDARDS.

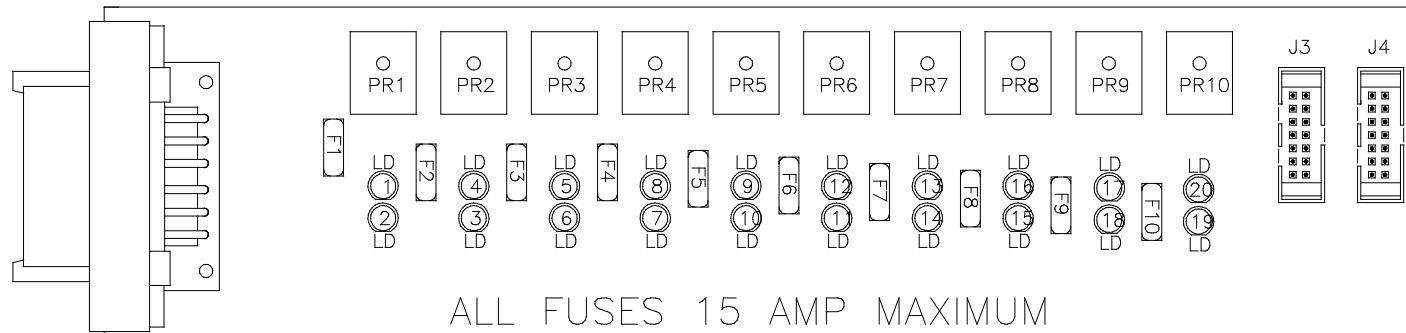

REAR AIR
LED LAYOUT

LED #	COLOR	FUSE #	OUTPUT	RELAY #	DESCRIPTION
LED1	YELLOW	---	---	PR1	LEFT REAR RAISE (COIL)
LED2	RED	FUSE 1	PIN 1	PR1	LEFT REAR RAISE (CONTACT)
LED3	RED	FUSE 2	PIN 2	PR2	LEFT REAR LOWER (CONTACT)
LED4	YELLOW	---	---	PR2	LEFT REAR LOWER (COIL)
LED5	YELLOW	---	---	PR3	LEFT REAR HIGH VOL RAISE (COIL)
LED6	RED	FUSE 3	PIN 3	PR3	LEFT REAR HIGH VOL RAISE (CONTACT)
LED7	RED	FUSE 4	PIN 4	PR4	NOT USED
LED8	YELLOW	---	---	PR4	NOT USED
LED9	YELLOW	---	---	PR5	RIGHT REAR RAISE (COIL)
LED10	RED	FUSE 5	PIN 5	PR5	RIGHT REAR RAISE (CONTACT)
LED11	RED	FUSE 6	PIN 6	PR6	RIGHT REAR LOWER (CONTACT)
LED12	YELLOW	---	---	PR6	RIGHT REAR LOWER (COIL)
LED13	YELLOW	---	---	PR7	RIGHT REAR HIGH VOL RAISE (COIL)
LED14	RED	FUSE 7	PIN 7	PR7	RIGHT REAR HIGH VOL RAISE (CONTACT)
LED15	RED	FUSE 8	PIN 8	PR8	NOT USED
LED16	YELLOW	---	---	PR8	NOT USED
LED17	YELLOW	---	---	PR9	NOT USED
LED18	RED	FUSE 9	PIN 9	PR9	NOT USED
LED19	RED	FUSE 10	PIN 10	PR10	NOT USED
LED20	YELLOW	---	---	PR10	NOT USED

NOTE: INSTALLATION MUST CONFORM TO GOOD SHOP PRACTICES, SAE STANDARDS, RVIA STANDARDS, AND OTHER APPLICABLE STANDARDS.

MP90847 Q
06FEB13