

FRONT VIEW - AP49063

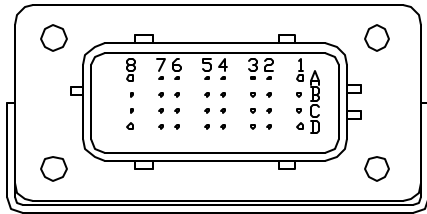

- PIN
- A1. BLK(W8601) - PUMP REQUEST
 - A2. YELLOW - CAN HIGH
 - A3. N/C
 - A4. N/C
 - A5. BLK(W2000) - RIGHT FRONT JACK WARNING SWITCH
 - A6. BLK(W2200) - RIGHT FRONT JACK PRESSURE SWITCH
 - A7. BLK(W3200) - RIGHT REAR JACK PRESSURE SWITCH
 - A8. BLK(W8101) - NOT USED
 - B1. RED(W6800) - TOUCH PANEL POWER
 - B2. GREEN - CAN LOW
 - B3. WHT(W6230) - TOUCH PANEL GROUND
 - B4. N/C
 - B5. BLK(W3000) - RIGHT REAR JACK WARNING SWITCH
 - B6. BLK(W4200) - LEFT REAR JACK PRESSURE SWITCH
 - B7. N/C
 - B8. BLK(W8100) - 3000 LB. PRESSURE SWITCH
 - C1. RED(W6121) - LEVEL SENSOR POWER
 - C2. CAN SHIELD
 - C3. WHT(W6231) - LEVEL SENSOR GROUND
 - C4. BLK(W0400) - REAR SENSE
 - C5. BLK(W4000) - LEFT REAR JACK WARNING SWITCH
 - C6. N/C
 - C7. N/C
 - C8. BLK(W0300) - RIGHT SIDE SENSE
 - D1. RED(W6120) - ACCESSORY
 - D2. WHT(W6235) - WARNING SWITCH GROUND
 - D3. N/C
 - D4. BLK(W1000) - LEFT FRONT JACK WARNING SWITCH
 - D5. BLK(W1200) - LEFT FRONT JACK PRESSURE SWITCH
 - D6. BLK(W0100) - LEFT SIDE SENSE
 - D7. BLK(W0200) - FRONT SENSE
 - D8. BLK(W9000) - PARK BRAKE
- NOTE: WIRE NUMBERS ON THIS SHEET ARE REFERENCED TO HARNESS PLUGS.

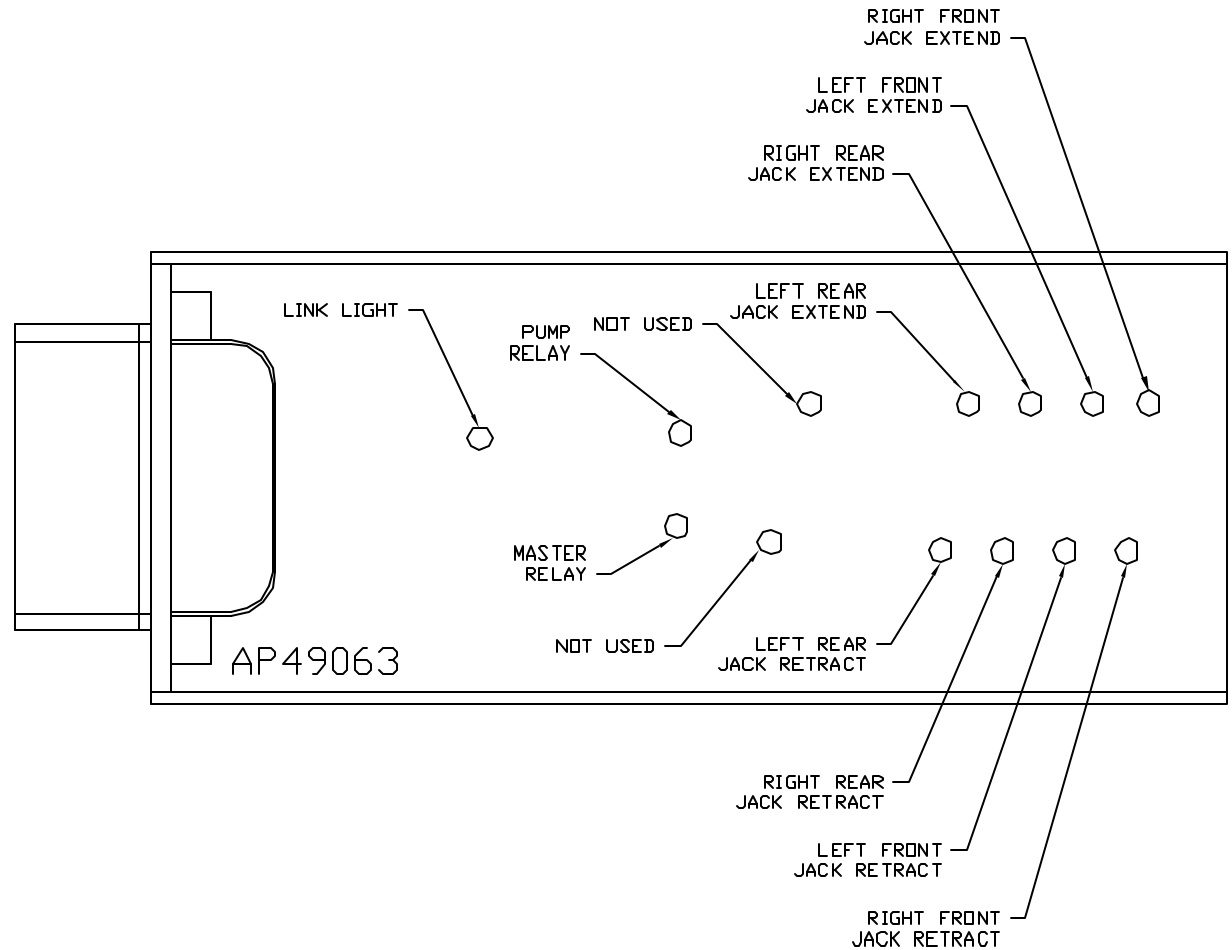

		HWH		I-80 EXIT 267 SOUTH RT 1 MOSCOW, IOWA 52760	
		SCALE 1:3	DATE 09JUN15	DRAWN BY .	
		SYSTEM SCHEMATIC ELEC			
NO.	DATE	REVISION			
THE INFORMATION DISCLOSED ON THIS DRAWING IS CONFIDENTIAL AND MUST NOT BE DISCLOSED OR USED IN ANY MANNER WHICH WILL BE DETRIMENTAL TO THE HWH CORPORATION				DRAWING NUMBER MP91144 A/E	

NOTE: INSTALLATION MUST CONFORM TO GOOD SHOP PRACTICES, SAE STANDARDS, RVIA STANDARDS, AND OTHER APPLICABLE STANDARDS.

PIN

1. BLK(W6810) SW. BATTERY FROM PUMP RELAY
2. BLK(W6800) SW. BATTERY FROM MASTER RELAY
3. BLK(W8601) PUMP (HAS DIODE)
4. WHT(W6230) GROUND

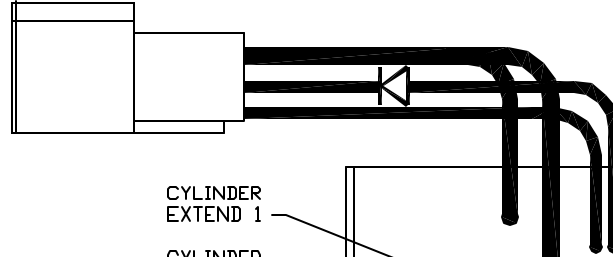
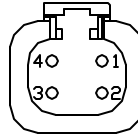

CYLINDER
EXTEND 1

CYLINDER
RETRACT 1

NOT USED

NOT USED

PUMP

PIN

1. BLK(W5000) EXTEND ROOM 1
2. BLK(W5100) RETRACT ROOM 1
3. N/C
4. N/C
5. N/C
6. N/C
7. RED(W6805) +12V TO ROOM SWITCHES
8. N/C
9. N/C
10. N/C
11. N/C
12. N/C

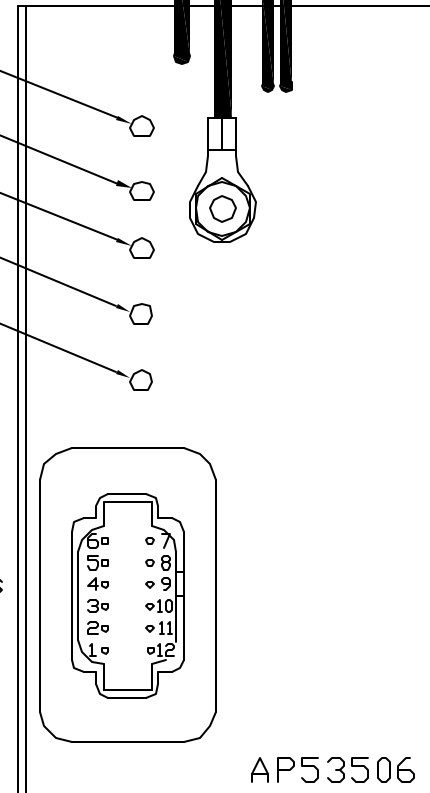

NOTE: INSTALLATION MUST CONFORM TO GOOD SHOP PRACTICES, SAE STANDARDS, RVIA STANDARDS, AND OTHER APPLICABLE STANDARDS.

MP91144 B
09JUN15

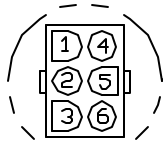

DETAIL A

- PIN
 1. N/C
 2. N/C
 3. N/C
 4. N/C
 5. BLK(W7699) WARNING LED/ALARM CONTROL
 6. N/C

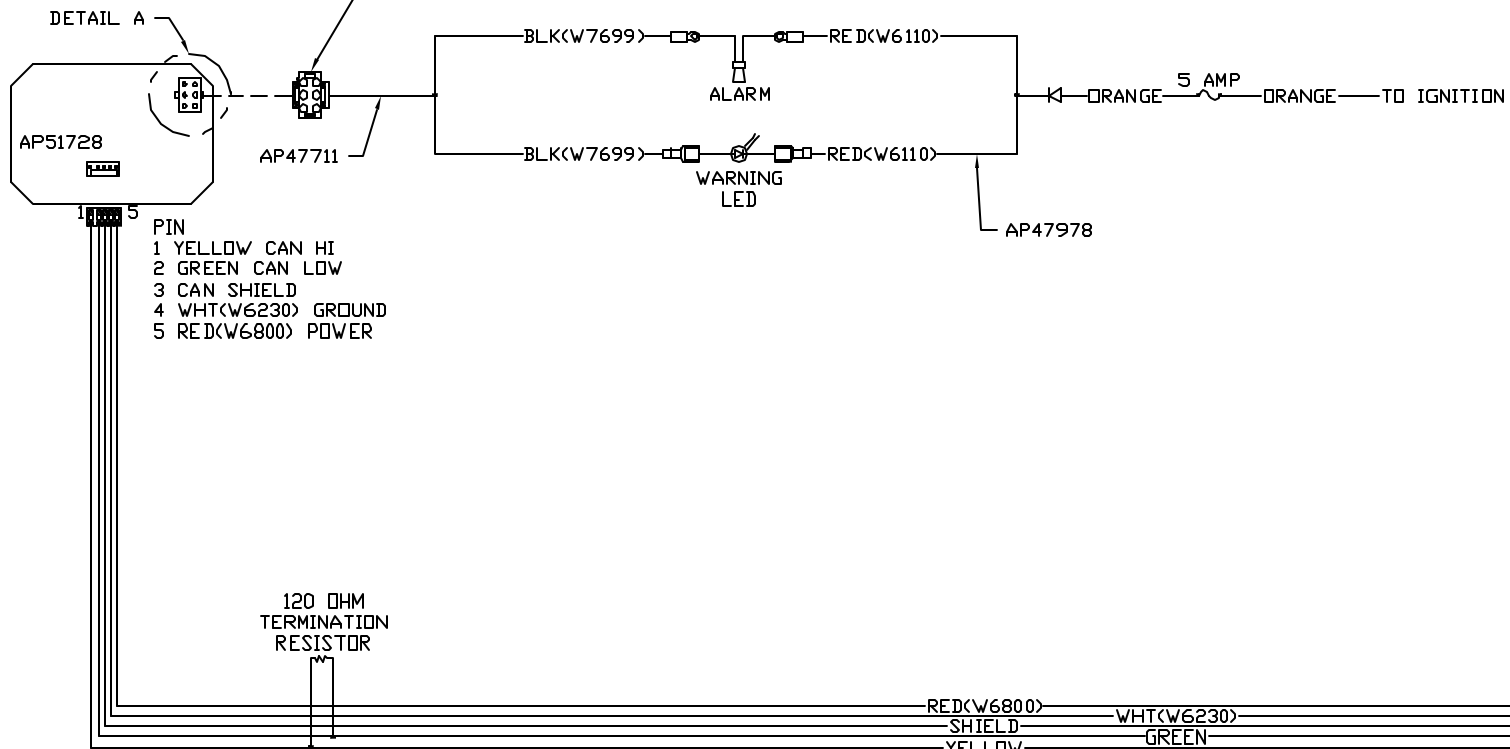

- PIN
 1 YELLOW CAN HI
 2 GREEN CAN LOW
 3 CAN SHIELD
 4 WHT(W6230) GROUND
 5 RED(W6800) POWER

120 OHM
 TERMINATION
 RESISTOR

RED(W6800)
 SHIELD
 YELLOW
 WHT(W6230)
 GREEN

NOTE: INSTALLATION MUST CONFORM TO GOOD SHOP PRACTICES, SAE STANDARDS, RVIA STANDARDS, AND OTHER APPLICABLE STANDARDS.

AP54453

MP91144 C
 09JUN15

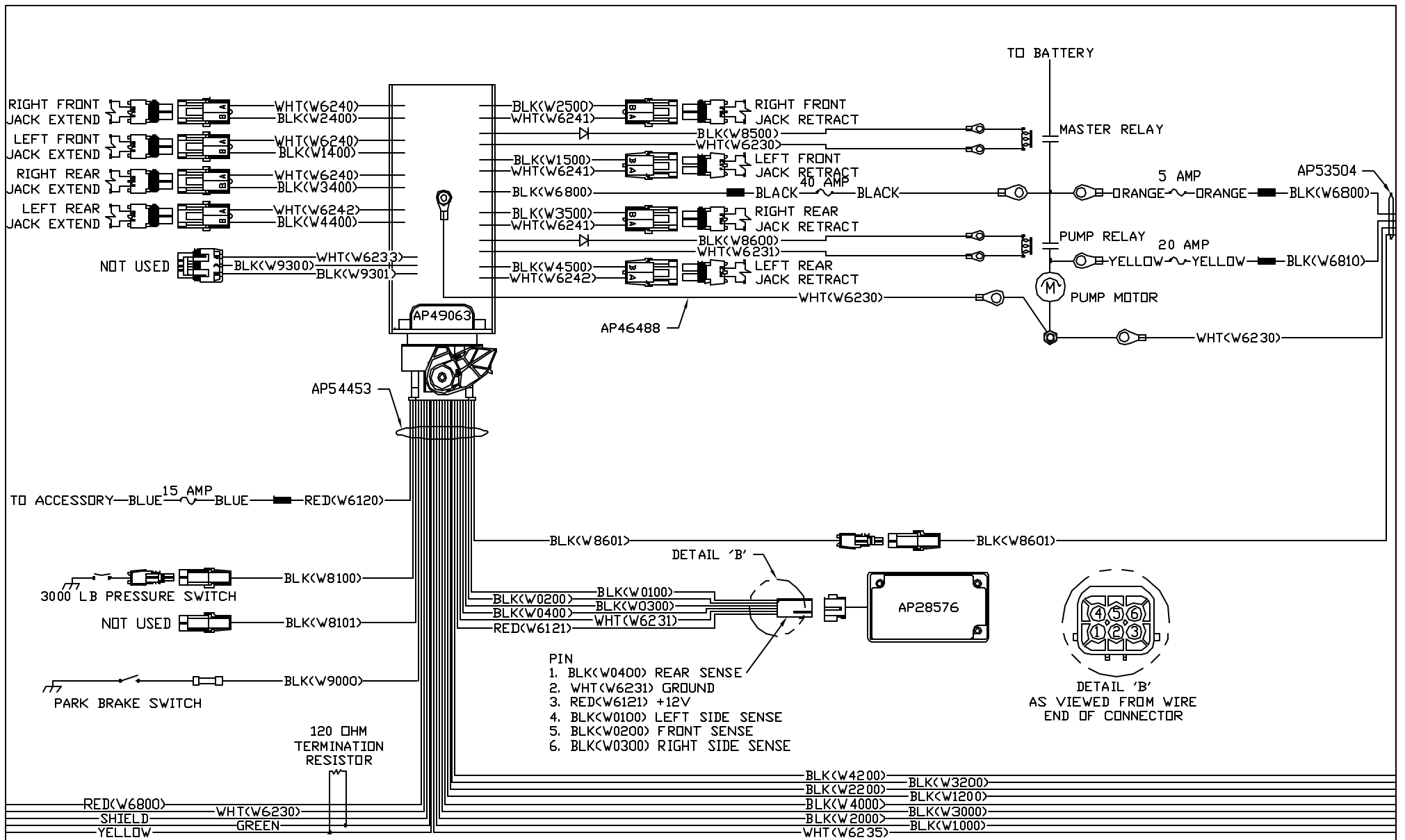

NOTE: INSTALLATION MUST CONFORM TO GOOD SHOP PRACTICES, SAE STANDARDS, RVIA STANDARDS, AND OTHER APPLICABLE STANDARDS.

MP91144 D
09JUN15

