

FRONT VIEW - AP48445

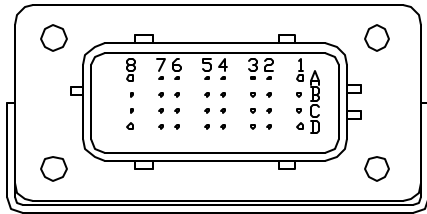

- PIN
- A1. RED(W6120) - ACCESSORY
  - A2. YELLOW - CAN HIGH
  - A3. N/C
  - A4. N/C
  - A5. N/C
  - A6. BLK(W2210) - RIGHT FRONT AIR PRESSURE SWITCH
  - A7. N/C
  - A8. N/C
  - B1. RED(W6122) - TOUCH PANEL POWER
  - B2. GREEN - CAN LOW
  - B3. N/C
  - B4. N/C
  - B5. N/C
  - B6. N/C
  - B7. N/C
  - B8. N/C
  - C1. RED(W6121) - LEVEL SENSOR POWER
  - C2. CAN SHIELD
  - C3. WHT(W6231) - LEVEL SENSOR GROUND
  - C4. BLK(W0400) - REAR SENSE
  - C5. N/C
  - C6. BLK(W9900) - SPEED SWITCH
  - C7. N/C
  - C8. BLK(W0300) - RIGHT SIDE SENSE
  - D1. RED(W6102) - SW. BATTERY
  - D2. WHT(W6232) - PRESSURE SWITCH GROUND
  - D3. WHT(W6230) - SYSTEM GROUND
  - D4. N/C
  - D5. BLK(W1210) - LEFT FRONT AIR PRESSURE SWITCH
  - D6. BLK(W0100) - LEFT SIDE SENSE
  - D7. BLK(W0200) - FRONT SENSE
  - D8. BLK(W9000) - PARK BRAKE

NOTE: WIRE NUMBERS ON THIS SHEET ARE REFERENCED TO HARNESS PLUGS.

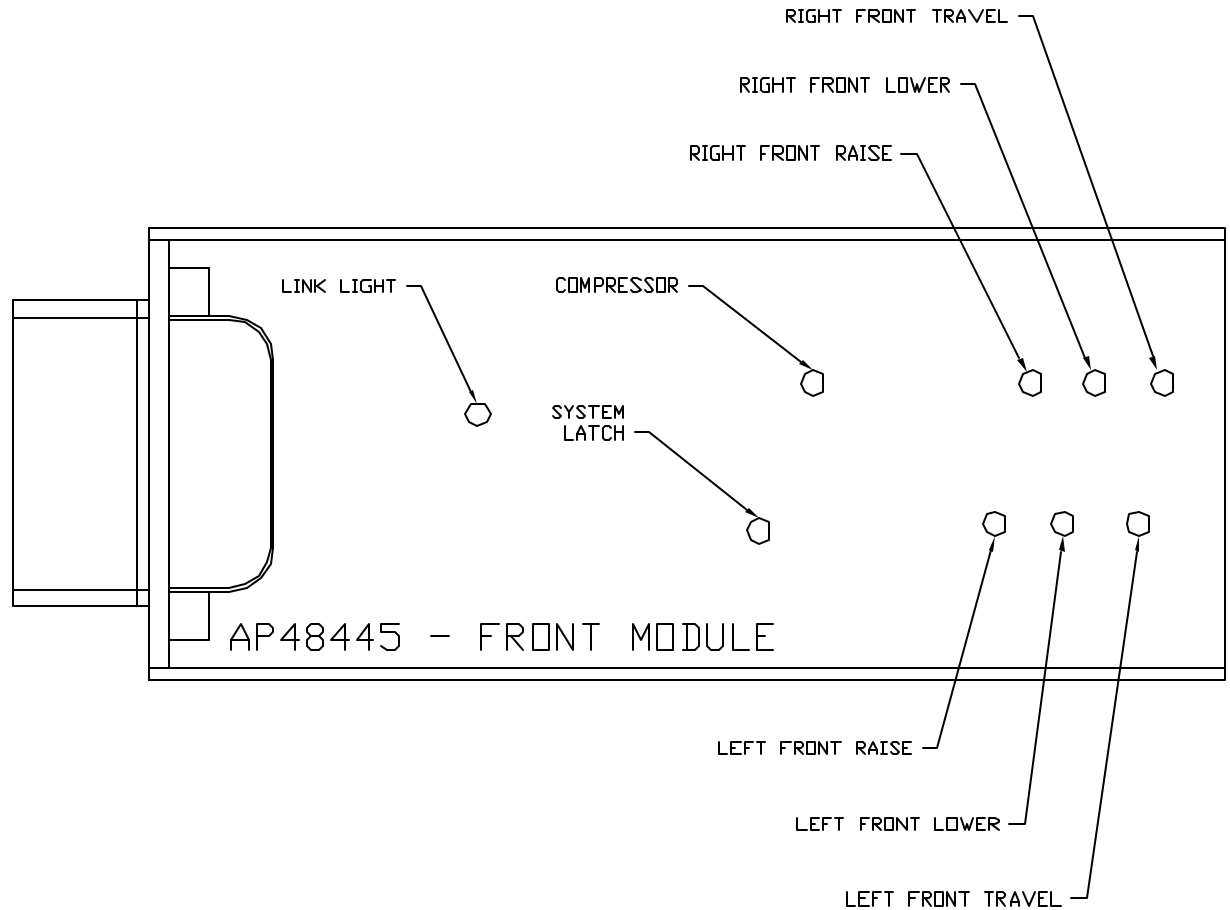

NOTE: INSTALLATION MUST CONFORM TO GOOD SHOP PRACTICES, SAE STANDARDS, RVIA STANDARDS, AND OTHER APPLICABLE STANDARDS.

		<b>HWH</b>		I-80 EXIT 267 SOUTH RT 1 MOSCOW, IOWA 52760	
		SCALE 1:3	DATE 23NOV15	DRAWN BY .	
		SYSTEM SCHEMATIC ELEC			
NO.	DATE	REVISION			
		THE INFORMATION DISCLOSED ON THIS DRAWING IS CONFIDENTIAL AND MUST NOT BE DISCLOSED OR USED IN ANY MANNER WHICH WILL BE DETRIMENTAL TO THE HWH CORPORATION			
				DRAWING NUMBER MP91181 A/F	

FRONT VIEW - AP48446

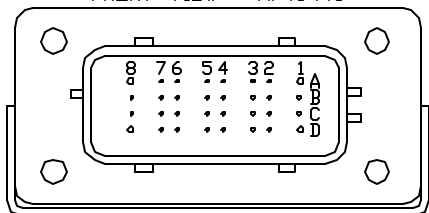

- PIN
- A1. N/C
  - A2. YELLOW - CAN HIGH
  - A3. N/C
  - A4. N/C
  - A5. N/C
  - A6. BLK(W3210) - RIGHT REAR AIR PRESSURE SWITCH
  - A7. N/C
  - A8. N/C
  - B1. N/C
  - B2. GREEN - CAN LOW
  - B3. N/C
  - B4. N/C
  - B5. N/C
  - B6. N/C
  - B7. N/C
  - B8. BLK(W3215) - SYSTEM AIR PRESSURE SWITCH
  - C1. N/C
  - C2. CAN SHIELD
  - C3. N/C
  - C4. N/C
  - C5. N/C
  - C6. N/C
  - C7. N/C
  - C8. N/C
  - D1. RED(W6122) - SW. BATTERY
  - D2. WHT(W6233) - PRESSURE SWITCH GROUND
  - D3. WHT(W6230) - SYSTEM GROUND
  - D4. N/C
  - D5. BLK(W4210) - LEFT REAR AIR PRESSURE SWITCH
  - D6. N/C
  - D7. N/C
  - D8. N/C

NOTE: WIRE NUMBERS ON THIS SHEET ARE REFERENCED TO HARNESS PLUGS.

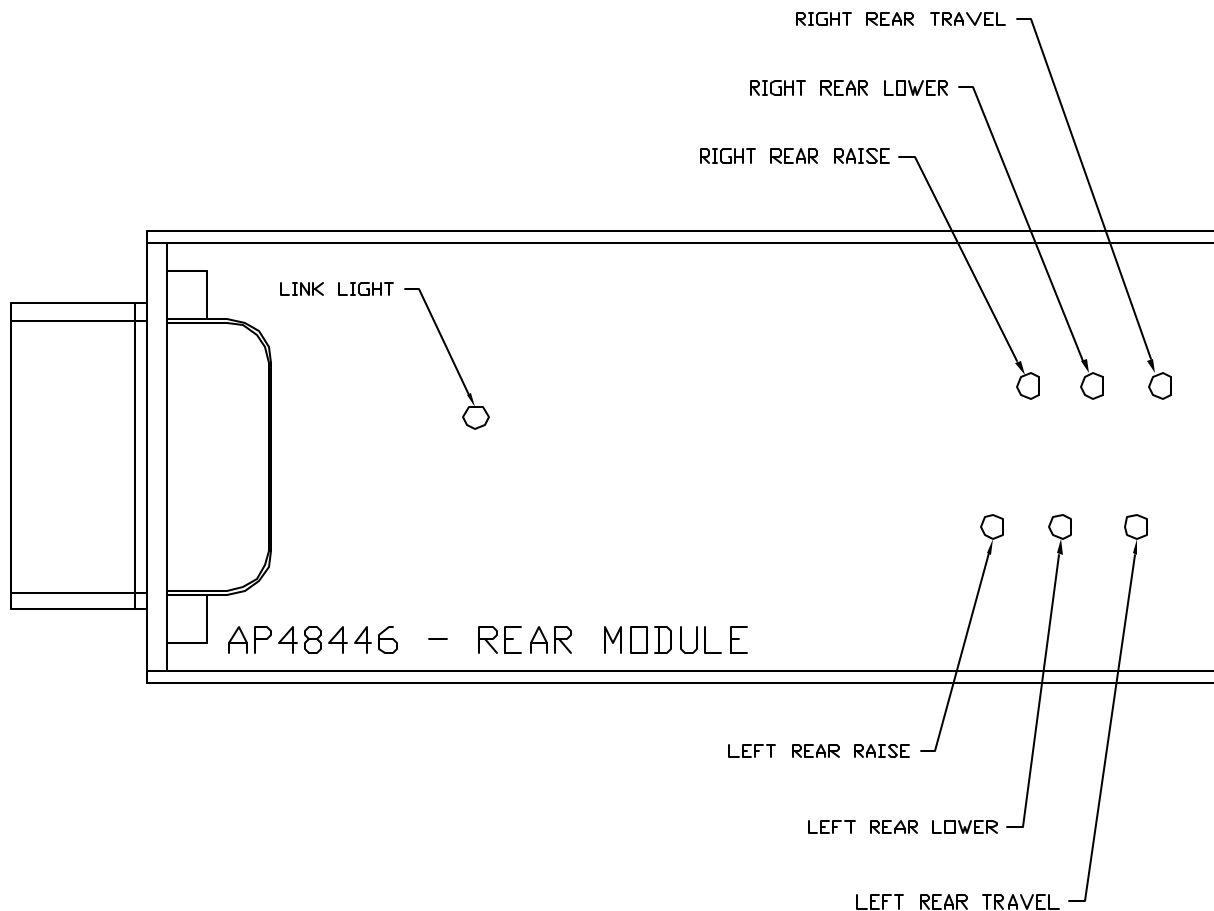

NOTE: INSTALLATION MUST CONFORM TO GOOD SHOP PRACTICES, SAE STANDARDS, RVIA STANDARDS, AND OTHER APPLICABLE STANDARDS.

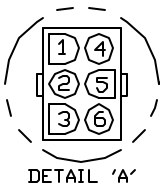

- PIN
- 1. N/C
  - 2. RED(W6110) WARNING LED SUPPLY
  - 3. N/C
  - 4. N/C
  - 5. BLK(W7699) WARNING LED CONTROL
  - 6. N/C

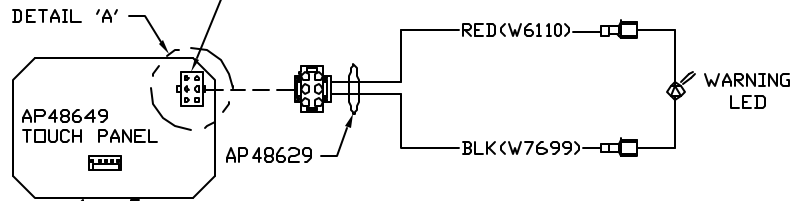

- PIN
- 1 YELLOW CAN HI
  - 2 GREEN CAN LOW
  - 3 CAN SHIELD
  - 4 WHT(W6230) GROUND
  - 5 RED(W6800) POWER

120 OHM  
TERMINATION  
RESISTOR

RED(W6122)  
SHIELD  
YELLOW

WHT(W6230)  
GREEN

AP 48602

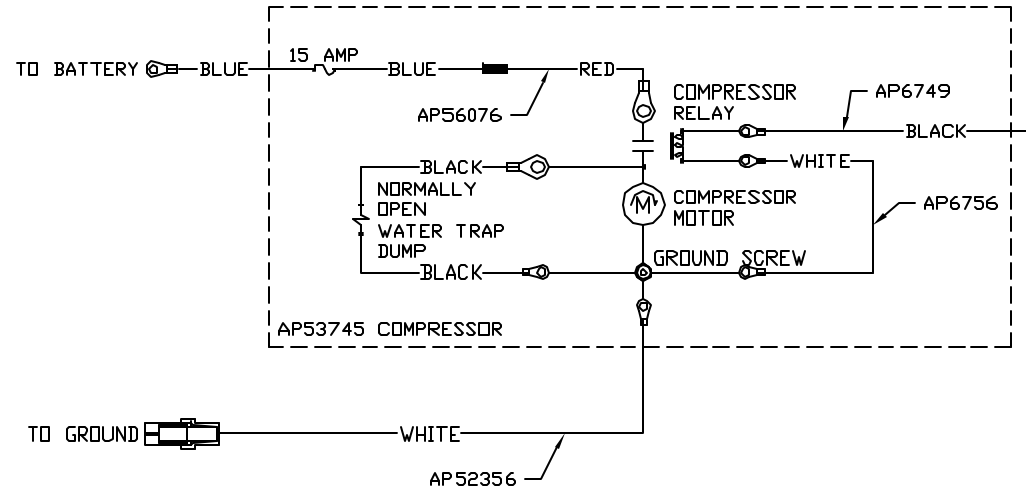

NOTE: INSTALLATION MUST CONFORM TO GOOD SHOP PRACTICES, SAE STANDARDS, RVIA STANDARDS, AND OTHER APPLICABLE STANDARDS.

MP91181 C  
23NOV15

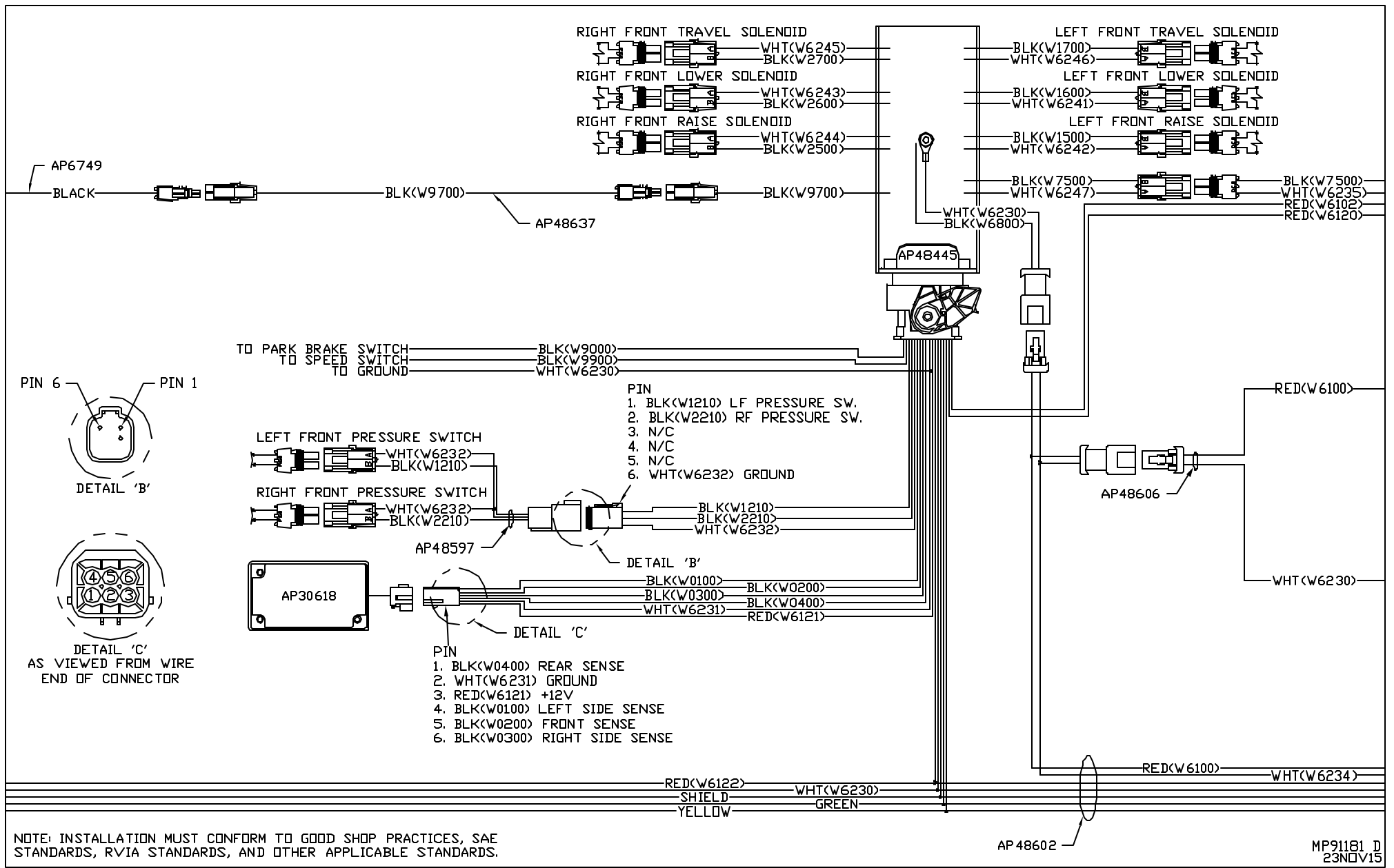

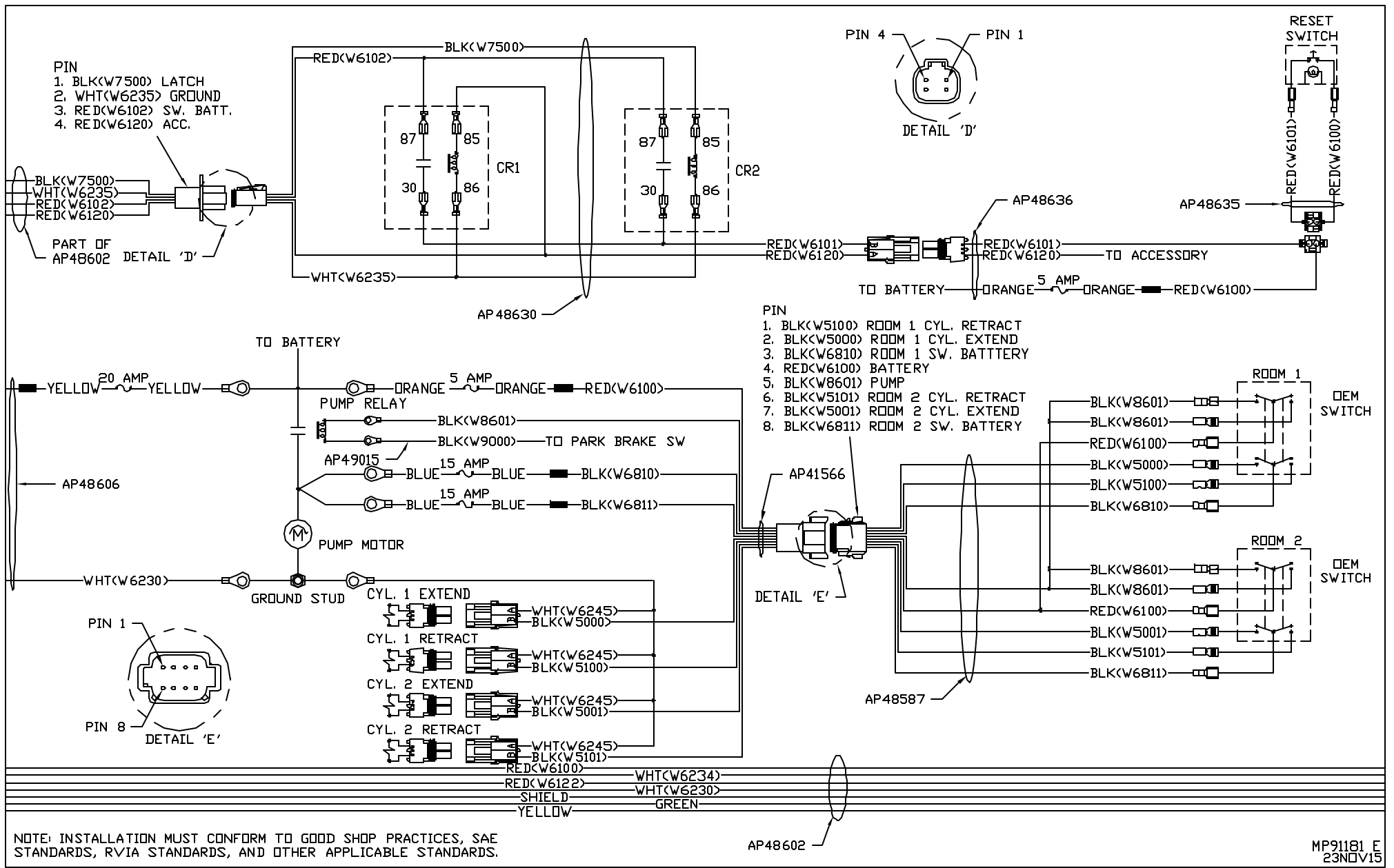

NOTE: INSTALLATION MUST CONFORM TO GOOD SHOP PRACTICES, SAE STANDARDS, RVIA STANDARDS, AND OTHER APPLICABLE STANDARDS.

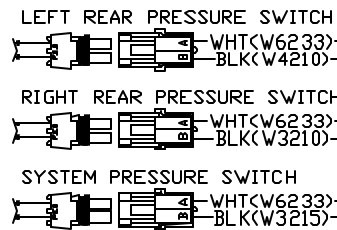
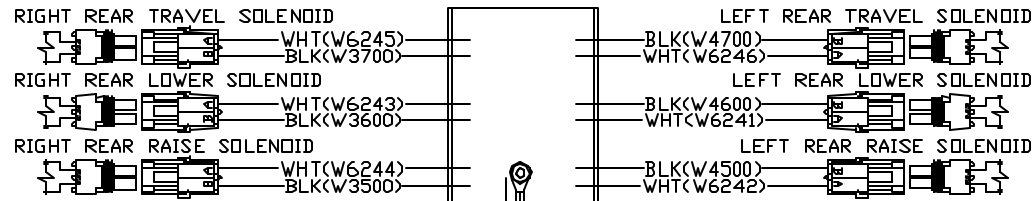
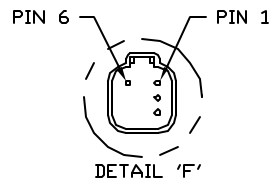

- PIN
1. BLK(W4210) LR PRESSURE SW.
  2. BLK(W3210) RR PRESSURE SW.
  3. BLK(W3215) SYS PRESSURE SW.
  4. N/C
  5. N/C
  6. WHT(W6233) GROUND

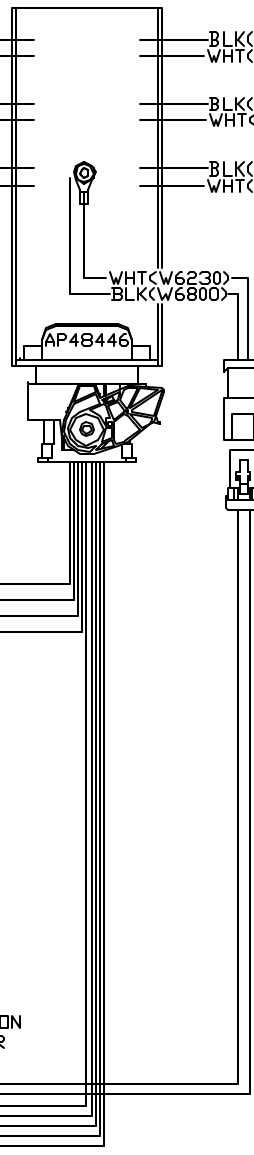
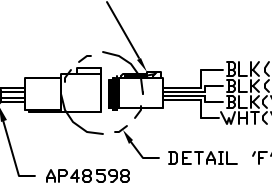

NOTE: INSTALLATION MUST CONFORM TO GOOD SHOP PRACTICES, SAE STANDARDS, RVIA STANDARDS, AND OTHER APPLICABLE STANDARDS.