

FRONT VIEW - AP49063

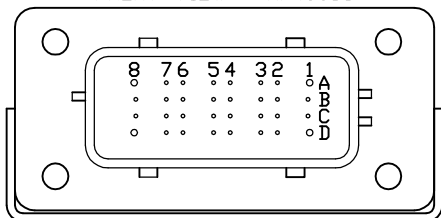

- PIN
- A1. BLK(W8601) - PUMP REQUEST
 - A2. YELLOW - CAN HIGH
 - A3. N/C
 - A4. N/C
 - A5. BLK(W2000) - RIGHT FRONT JACK WARNING SWITCH
 - A6. BLK(W2200) - RIGHT FRONT JACK PRESSURE SWITCH
 - A7. BLK(W3200) - RIGHT REAR JACK PRESSURE SWITCH
 - A8. BLK(W8101) - NOT USED
 - B1. RED(W6800) - TOUCH PANEL POWER
 - B2. GREEN - CAN LOW
 - B3. WHT(W6230) - TOUCH PANEL GROUND
 - B4. N/C
 - B5. BLK(W3000) - RIGHT REAR JACK WARNING SWITCH
 - B6. BLK(W4200) - LEFT REAR JACK PRESSURE SWITCH
 - B7. N/C
 - B8. BLK(W8100) - 3000 LB. PRESSURE SWITCH
 - C1. RED(W6121) - LEVEL SENSOR POWER
 - C2. CAN SHIELD
 - C3. WHT(W6231) - LEVEL SENSOR GROUND
 - C4. BLK(W0400) - REAR SENSE
 - C5. BLK(W4000) - LEFT REAR JACK WARNING SWITCH
 - C6. N/C
 - C7. N/C
 - C8. BLK(W0300) - RIGHT SIDE SENSE
 - D1. RED(W6120) - ACCESSORY
 - D2. WHT(W6235) - WARNING SWITCH GROUND
 - D3. N/C
 - D4. BLK(W1000) - LEFT FRONT JACK WARNING SWITCH
 - D5. BLK(W1200) - LEFT FRONT JACK PRESSURE SWITCH
 - D6. BLK(W0100) - LEFT SIDE SENSE
 - D7. BLK(W0200) - FRONT SENSE
 - D8. BLK(W9000) - PARK BRAKE

NOTE: WIRE NUMBERS ON THIS SHEET ARE REFERENCED TO HARNESS PLUGS.

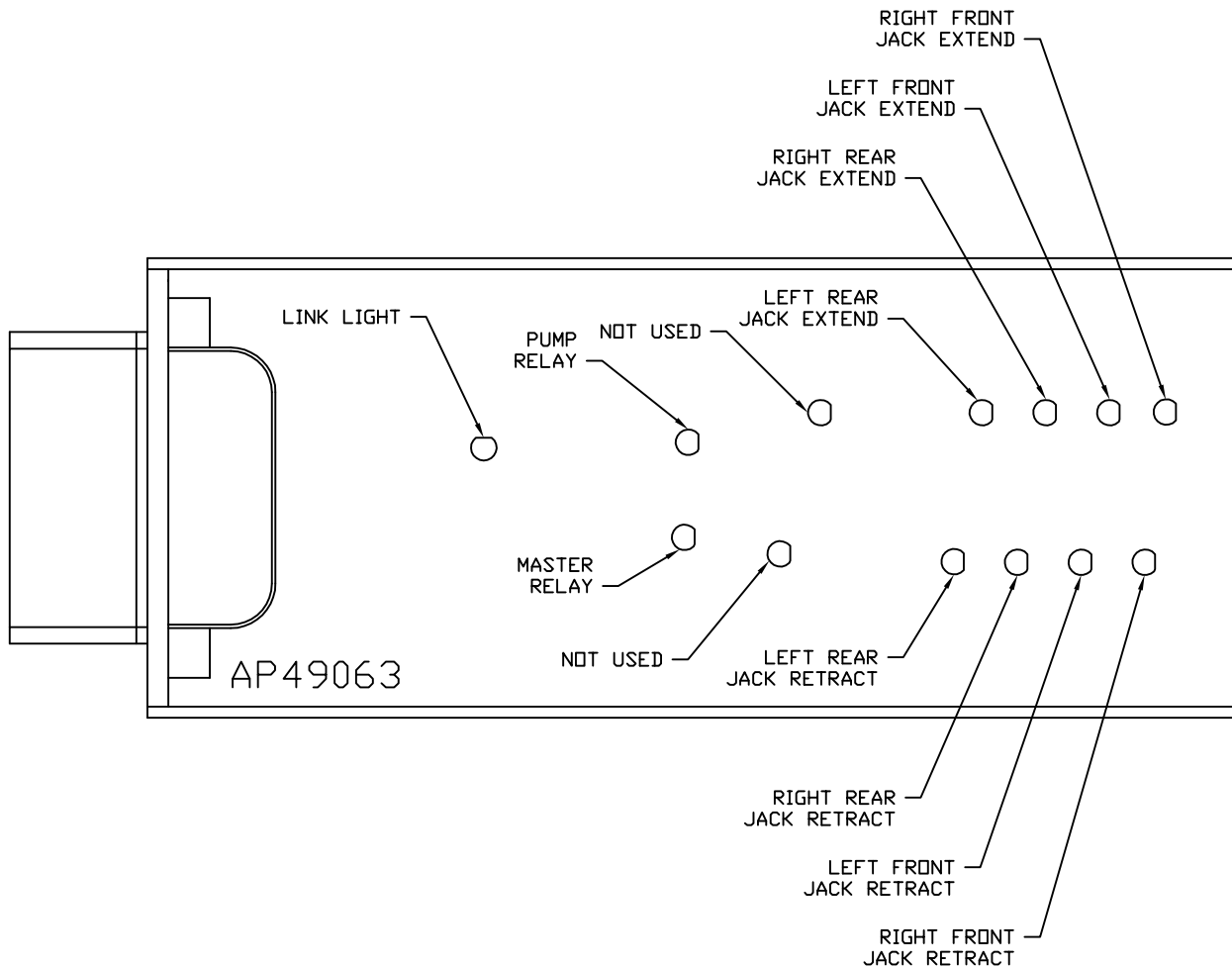

NOTE: INSTALLATION MUST CONFORM TO GOOD SHOP PRACTICES, SAE STANDARDS, RVIA STANDARDS, AND OTHER APPLICABLE STANDARDS.

		HWH		I-80 EXIT 267 SOUTH RT 1 MOSCOW, IOWA 52760	
		SCALE 1:3	DATE 28SEP17	DRAWN BY .	
		SYSTEM SCHEMATIC ELEC			
NO.	DATE	REVISION			
THE INFORMATION DISCLOSED ON THIS DRAWING IS CONFIDENTIAL AND MUST NOT BE DISCLOSED OR USED IN ANY MANNER WHICH WILL BE DETRIMENTAL TO THE HWH CORPORATION			DRAWING NUMBER MP91317 A/E		

PIN

1. BLK(W6810) SW. BATTERY FROM PUMP RELAY
2. BLK(W6800) SW. BATTERY FROM MASTER RELAY
3. BLK(W8601) PUMP (HAS DIODE)
4. WHT(W6230) GROUND

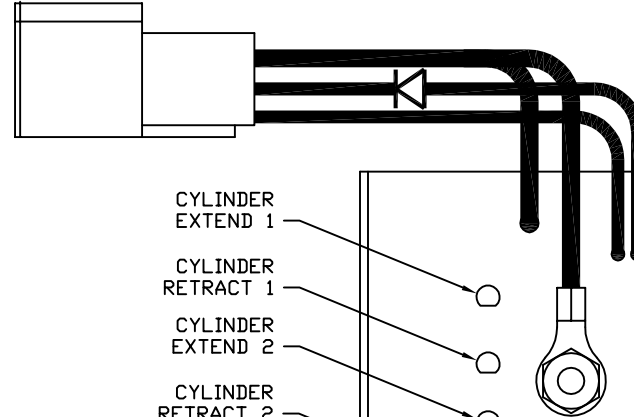
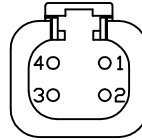

- CYLINDER EXTEND 1
- CYLINDER RETRACT 1
- CYLINDER EXTEND 2
- CYLINDER RETRACT 2
- PUMP

PIN

1. BLK(W5000) EXTEND ROOM 1
2. BLK(W5100) RETRACT ROOM 1
3. BLK(W5001) EXTEND ROOM 2
4. BLK(W5101) RETRACT ROOM 2
5. N/C
6. N/C
7. RED(W6805) +12V TO ROOM SWITCHES
8. N/C
9. N/C
10. N/C
11. N/C
12. N/C

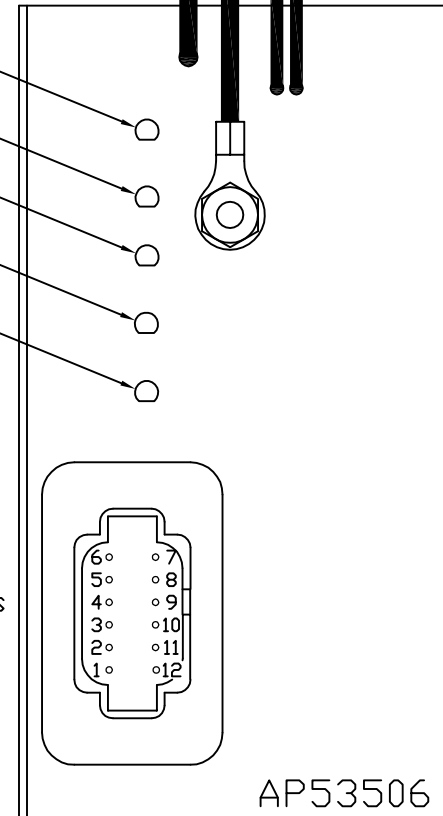

NOTE: INSTALLATION MUST CONFORM TO GOOD SHOP PRACTICES, SAE STANDARDS, RVIA STANDARDS, AND OTHER APPLICABLE STANDARDS.

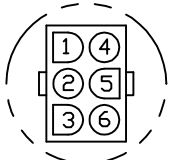

DETAIL A

- PIN
 1. N/C
 2. N/C
 3. N/C
 4. N/C
 5. BLK(W7699) WARNING LED/ALARM CONTROL
 6. N/C

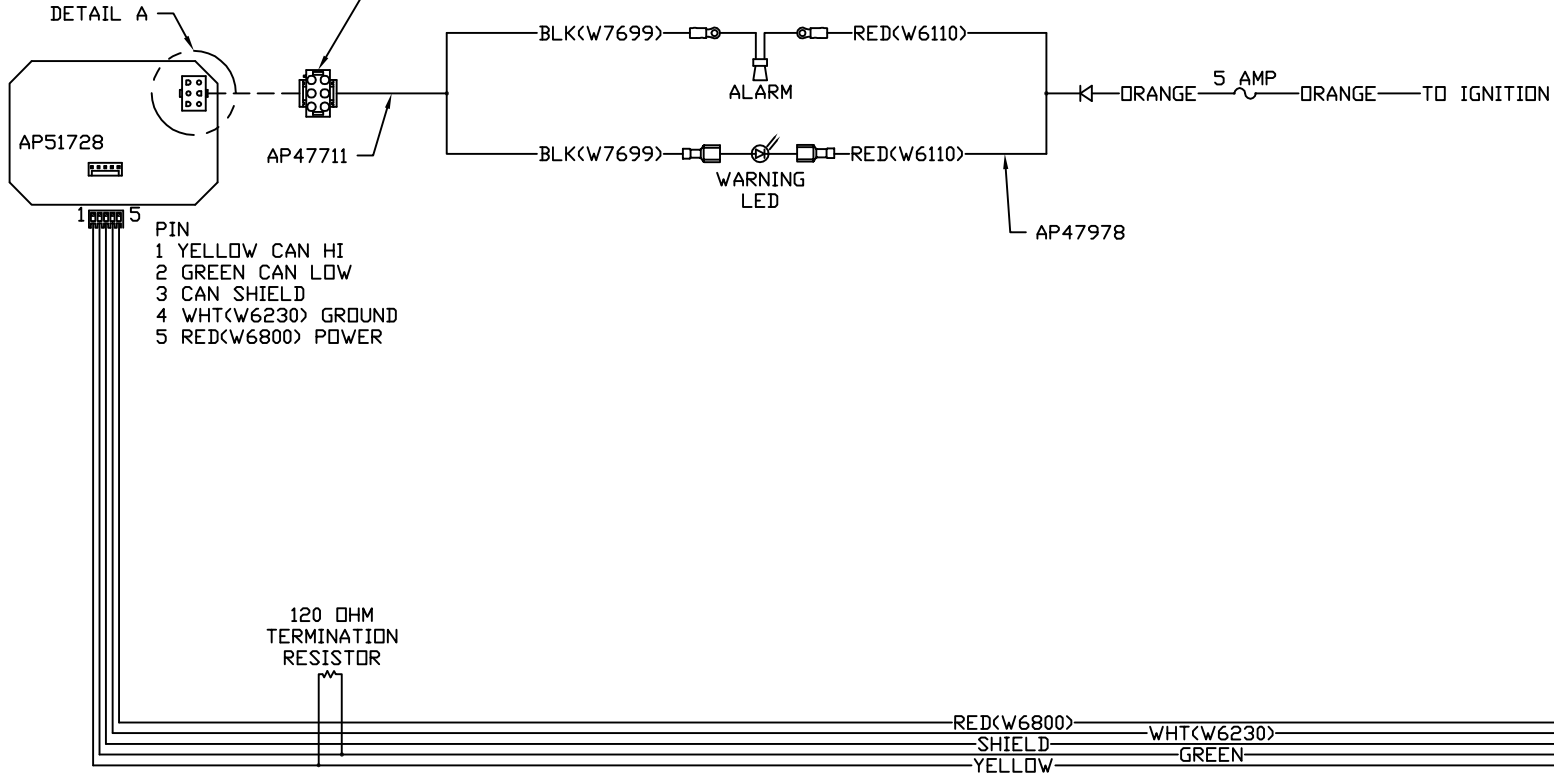

NOTE: INSTALLATION MUST CONFORM TO GOOD SHOP PRACTICES, SAE STANDARDS, RVIA STANDARDS, AND OTHER APPLICABLE STANDARDS.

RED(W6800)
 SHIELD
 YELLOW
 WHT(W6230)
 GREEN

AP54074

MP91317 C
 28SEP17

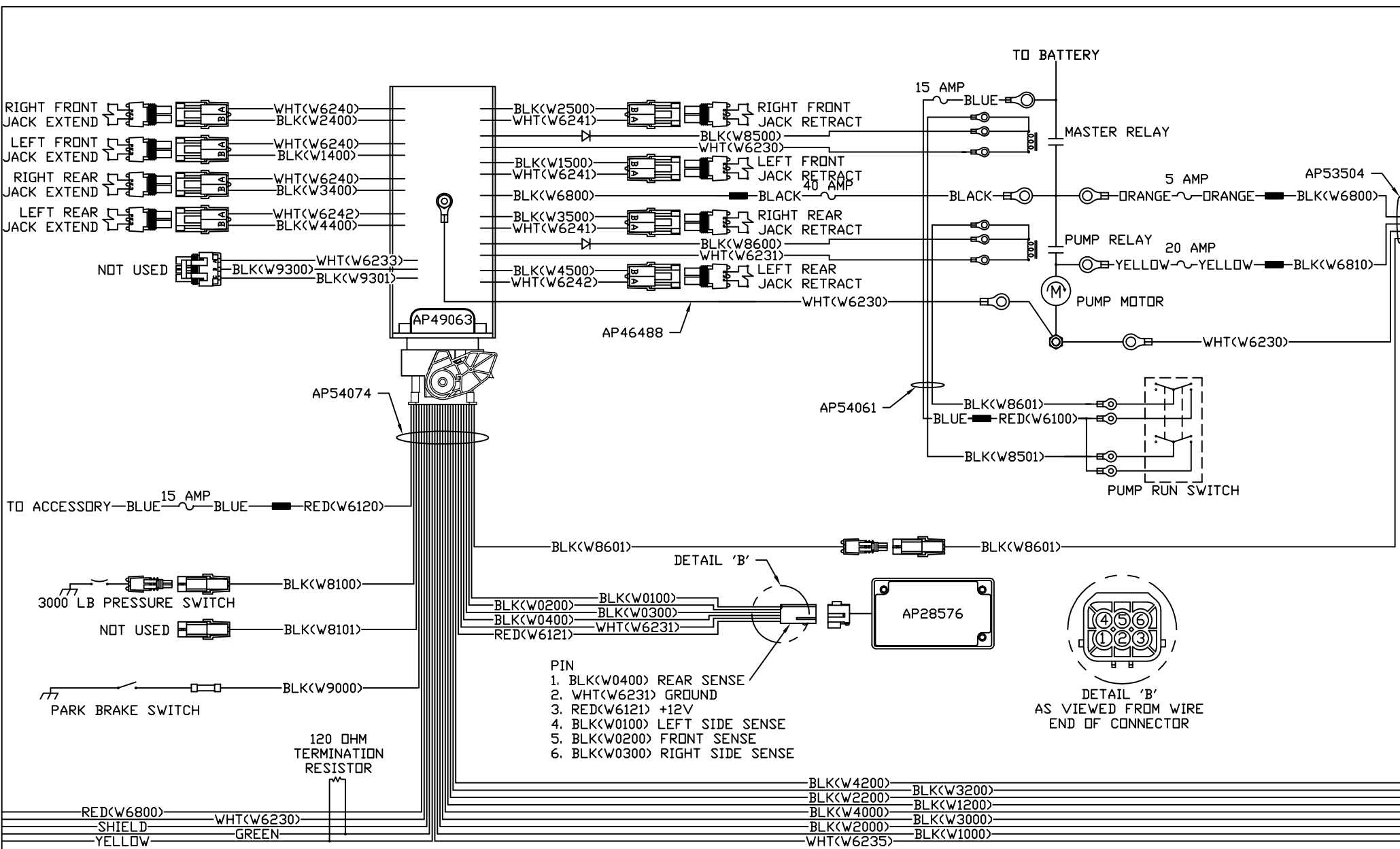

NOTE: INSTALLATION MUST CONFORM TO GOOD SHOP PRACTICES, SAE STANDARDS, RVIA STANDARDS, AND OTHER APPLICABLE STANDARDS.

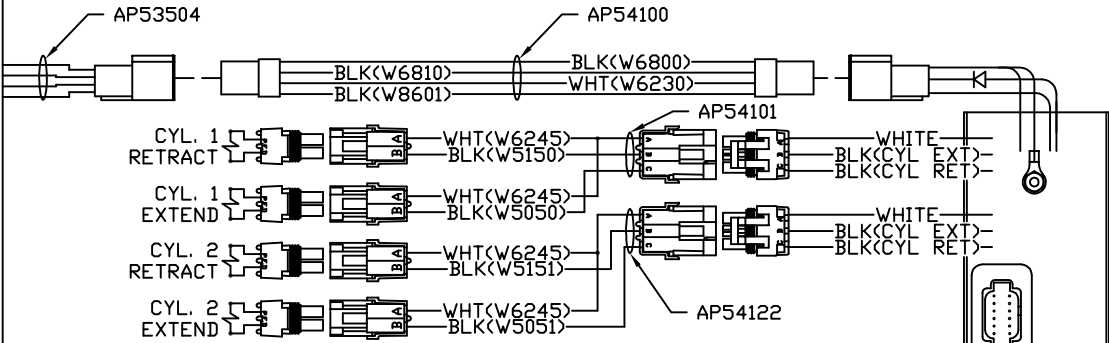
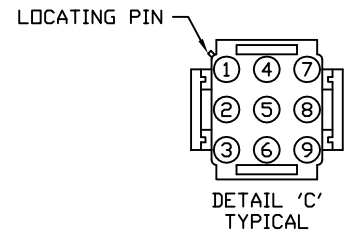

- 9 PIN
1. N/C
 2. BLK(W5000) EXTEND ROOM 1
 3. BLK(W5100) RETRACT ROOM 1
 4. - 6. N/C
 7. RED(W6805) POWER TO PANEL
 8. - 9. N/C

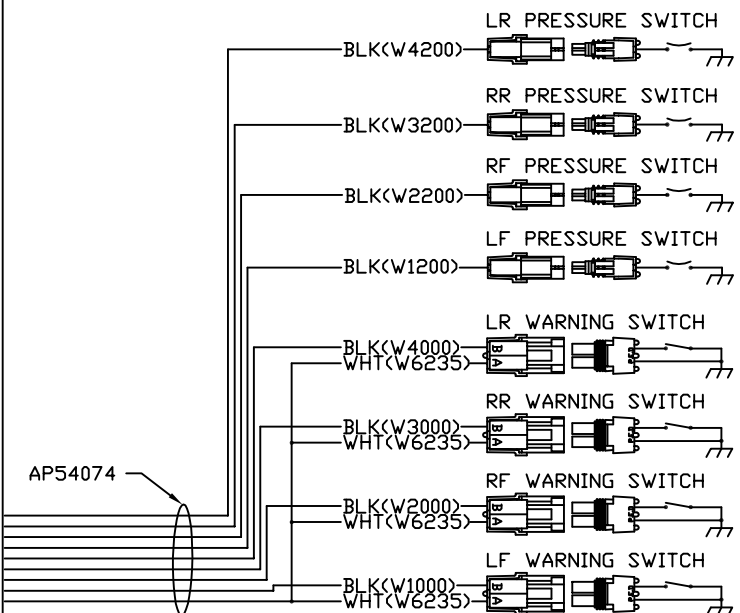

AP54803

- 9 PIN
1. N/C
 2. BLK(W5001) EXTEND ROOM 2
 3. BLK(W5101) RETRACT ROOM 2
 4. - 6. N/C
 7. RED(W6805) POWER TO PANEL
 8. - 9. N/C

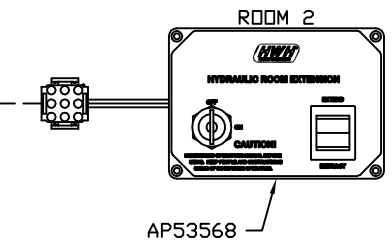
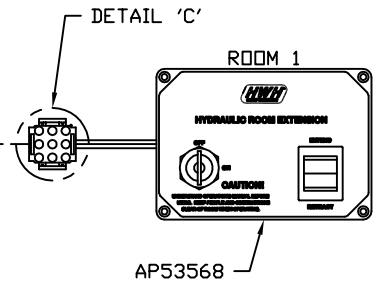

NOTE: INSTALLATION MUST CONFORM TO GOOD SHOP PRACTICES, SAE STANDARDS, RVIA STANDARDS, AND OTHER APPLICABLE STANDARDS.