

FRONT VIEW - AP58468

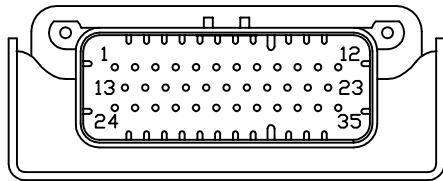

- PIN
1. BLK(W9000) - PARK BRAKE
 2. N/C
 3. BLK(W8101) - 50 LB. PRESSURE SWITCH
 4. BLK(W0100) - LEFT SIDE SENSE
 5. BLK(W0400) - REAR SENSE
 6. BLK(W3000) - RIGHT REAR JACK WARNING SWITCH
 7. BLK(W2200) - RIGHT FRONT JACK PRESSURE SWITCH
 8. N/C
 9. BLK(W8601) - PUMP REQUEST
 10. N/C
 11. WHT(W6235) - WARNING SWITCH GROUND
 12. N/C
 13. N/C
 14. N/C
 15. N/C
 16. BLK(W0300) - RIGHT SIDE SENSE
 17. BLK(W2000) - RIGHT FRONT JACK WARNING SWITCH
 18. BLK(W1200) - LEFT FRONT JACK PRESSURE SWITCH
 19. N/C
 20. WHT(W6230) - TOUCH PANEL GROUND
 21. CAN SHIELD
 22. YELLOW - CAN HIGH
 23. GREEN - CAN LOW
 24. N/C
 25. BLK(W4200) - LEFT REAR JACK PRESSURE SWITCH
 26. BLK(W8100) - 3000 LB. PRESSURE SWITCH
 27. BLK(W0200) - FRONT SENSE
 28. BLK(W1000) - LEFT FRONT JACK WARNING SWITCH
 29. BLK(W4000) - LEFT REAR JACK WARNING SWITCH
 30. BLK(W3200) - RIGHT REAR JACK PRESSURE SWITCH
 31. N/C
 32. WHT(W6231) - LEVEL SENSOR GROUND
 33. RED(W6121) - LEVEL SENSOR POWER
 34. RED(W6800) - TOUCH PANEL POWER
 35. RED(W6120) - ACCESSORY

NOTE: WIRE NUMBERS ON THIS SHEET ARE REFERENCED TO HARNESS PLUGS.

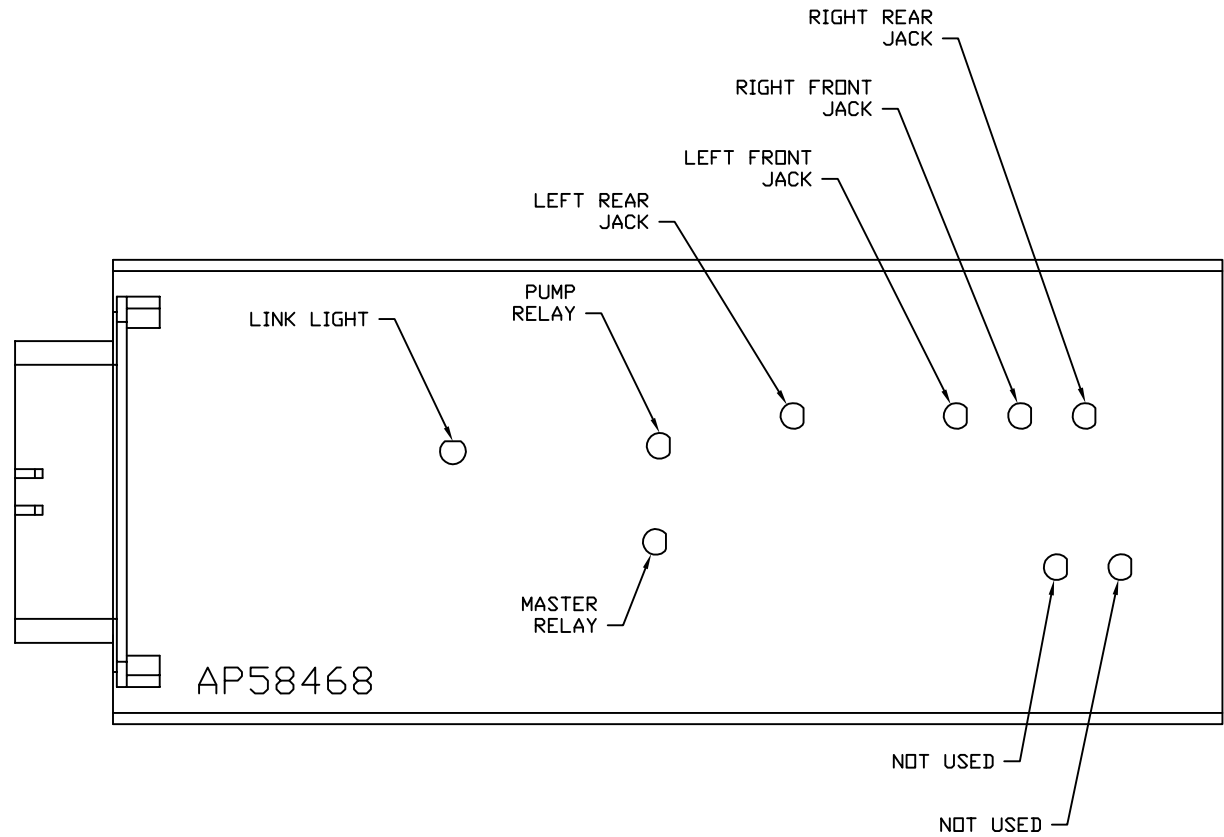

NOTE: INSTALLATION MUST CONFORM TO GOOD SHOP PRACTICES, SAE STANDARDS, RVIA STANDARDS, AND OTHER APPLICABLE STANDARDS.

		HWH		I-80 EXIT 267 SOUTH RT 1 MOSCOW, IOWA 52760	
		SCALE 1:3	DATE 08AUG19	DRAWN BY .	
		SYSTEM SCHEMATIC ELEC			
NO.	DATE	REVISION			
THE INFORMATION DISCLOSED ON THIS DRAWING IS CONFIDENTIAL AND MUST NOT BE DISCLOSED OR USED IN ANY MANNER WHICH WILL BE DETRIMENTAL TO THE HWH CORPORATION			DRAWING NUMBER MP91481 A/E		

PIN

1. BLK(W6810) SW. BATTERY FROM PUMP RELAY
2. BLK(W6800) SW. BATTERY FROM MASTER RELAY
3. BLK(W8601) PUMP (HAS DIODE)
4. WHT(W6230) GROUND

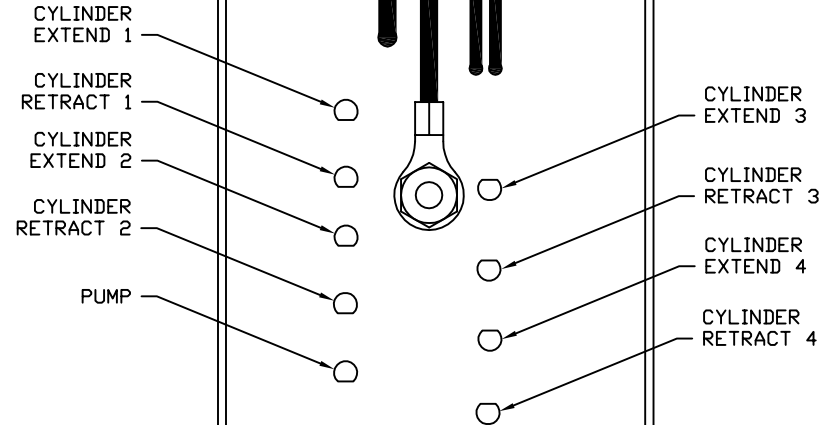
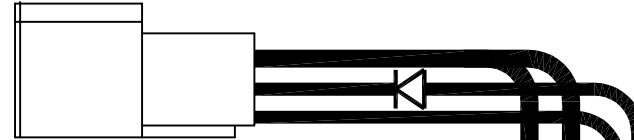
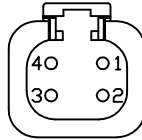

PIN

1. BLK(W5000) EXTEND ROOM 1
2. BLK(W5100) RETRACT ROOM 1
3. BLK(W5001) EXTEND ROOM 2
4. BLK(W5101) RETRACT ROOM 2
5. N/C
6. N/C
7. RED(W6805) +12V TO ROOM SWITCHES
8. N/C
9. BLK(W5002) EXTEND ROOM 3
10. BLK(W5102) RETRACT ROOM 3
11. BLK(W5003) EXTEND ROOM 4
12. BLK(W5103) RETRACT ROOM 4

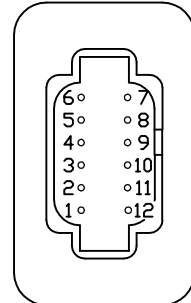

AP53292

NOTE: INSTALLATION MUST CONFORM TO GOOD SHOP PRACTICES, SAE STANDARDS, RVIA STANDARDS, AND OTHER APPLICABLE STANDARDS.

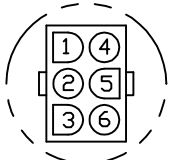

DETAIL A

- PIN
 1. N/C
 2. N/C
 3. N/C
 4. N/C
 5. BLK(W7699) WARNING LED/ALARM CONTROL
 6. N/C

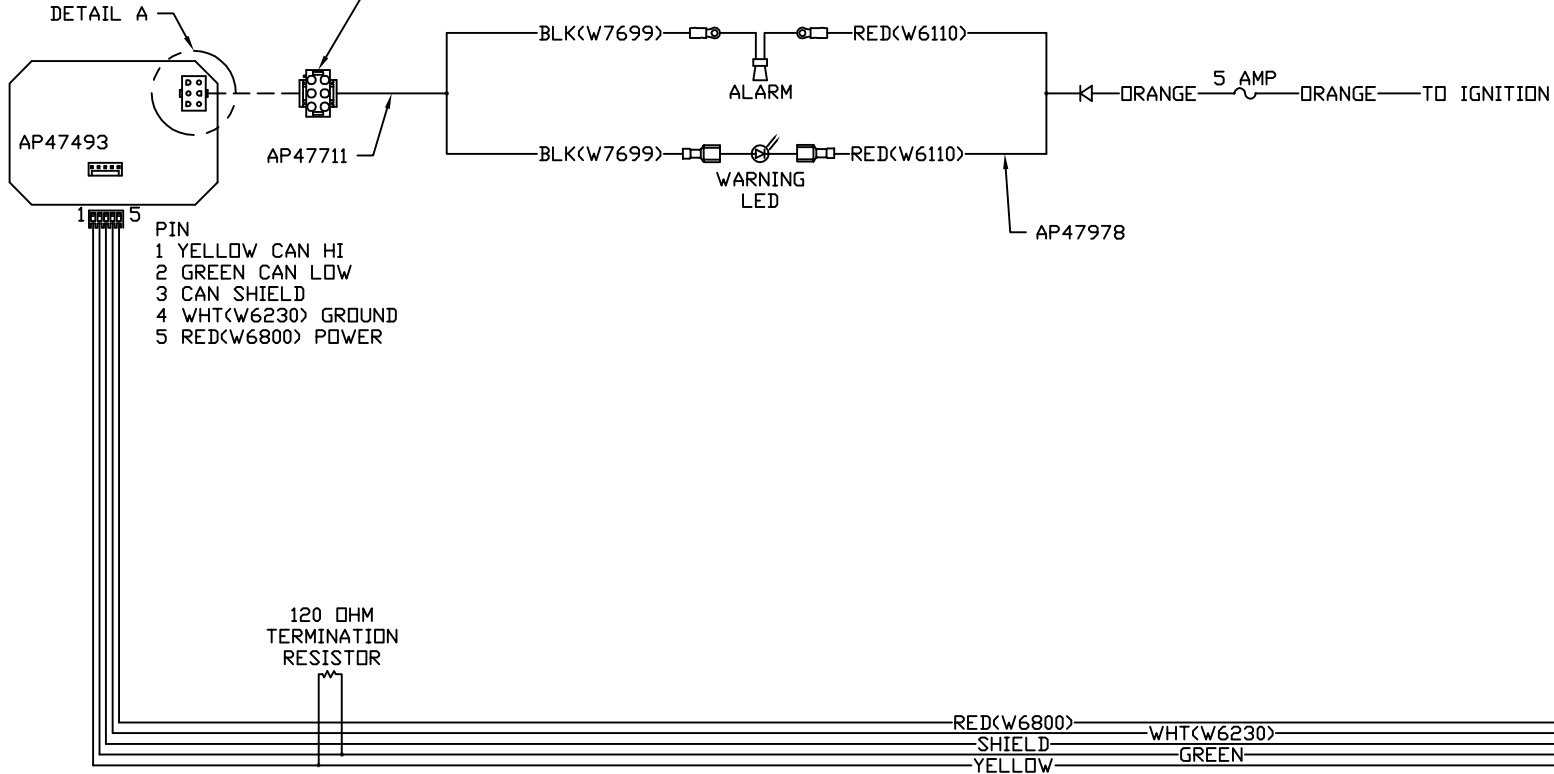

NOTE: INSTALLATION MUST CONFORM TO GOOD SHOP PRACTICES, SAE STANDARDS, RVIA STANDARDS, AND OTHER APPLICABLE STANDARDS.

AP59135

MP91481 C
 08AUG19

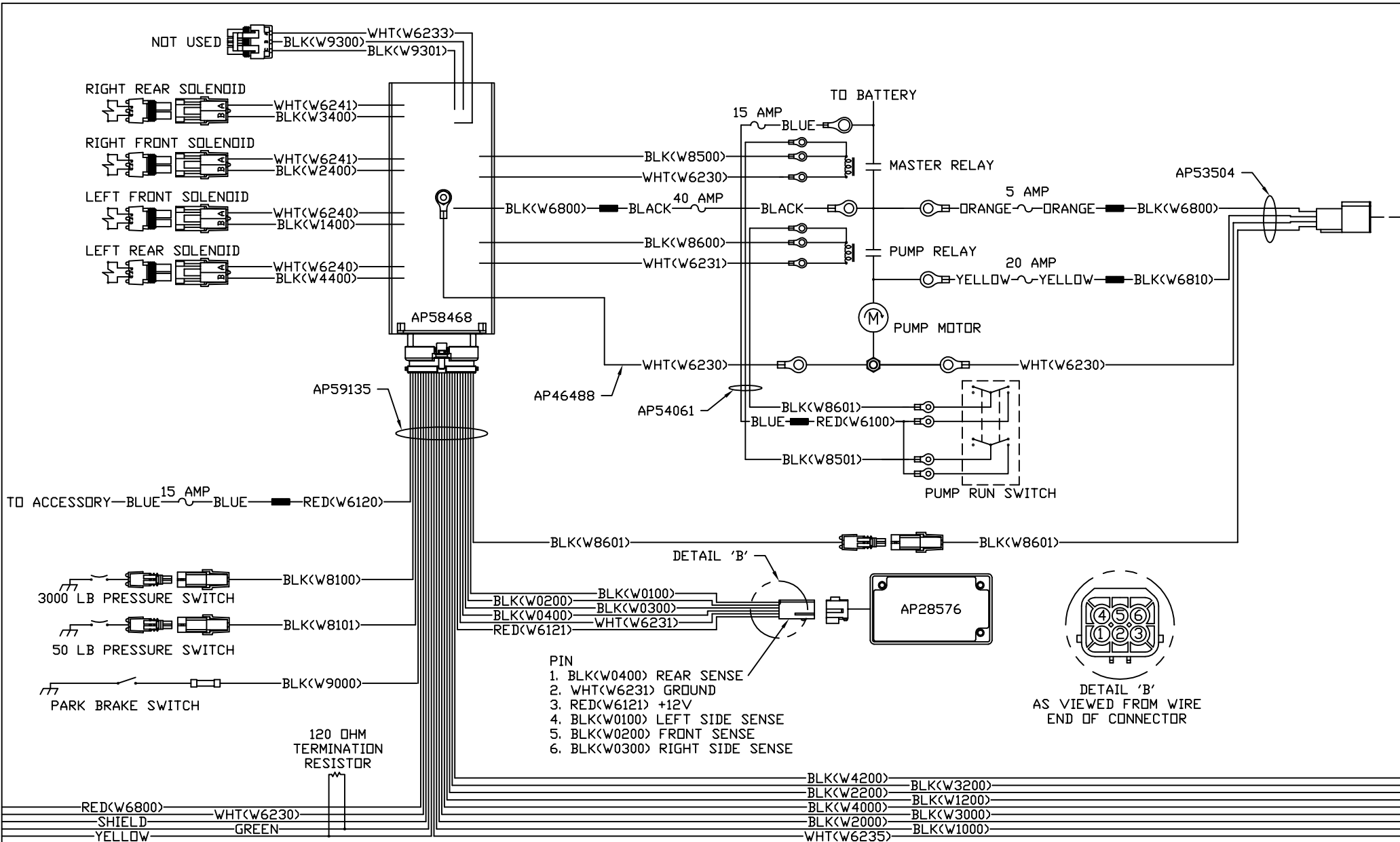

NOTE: INSTALLATION MUST CONFORM TO GOOD SHOP PRACTICES, SAE STANDARDS, RVIA STANDARDS, AND OTHER APPLICABLE STANDARDS.

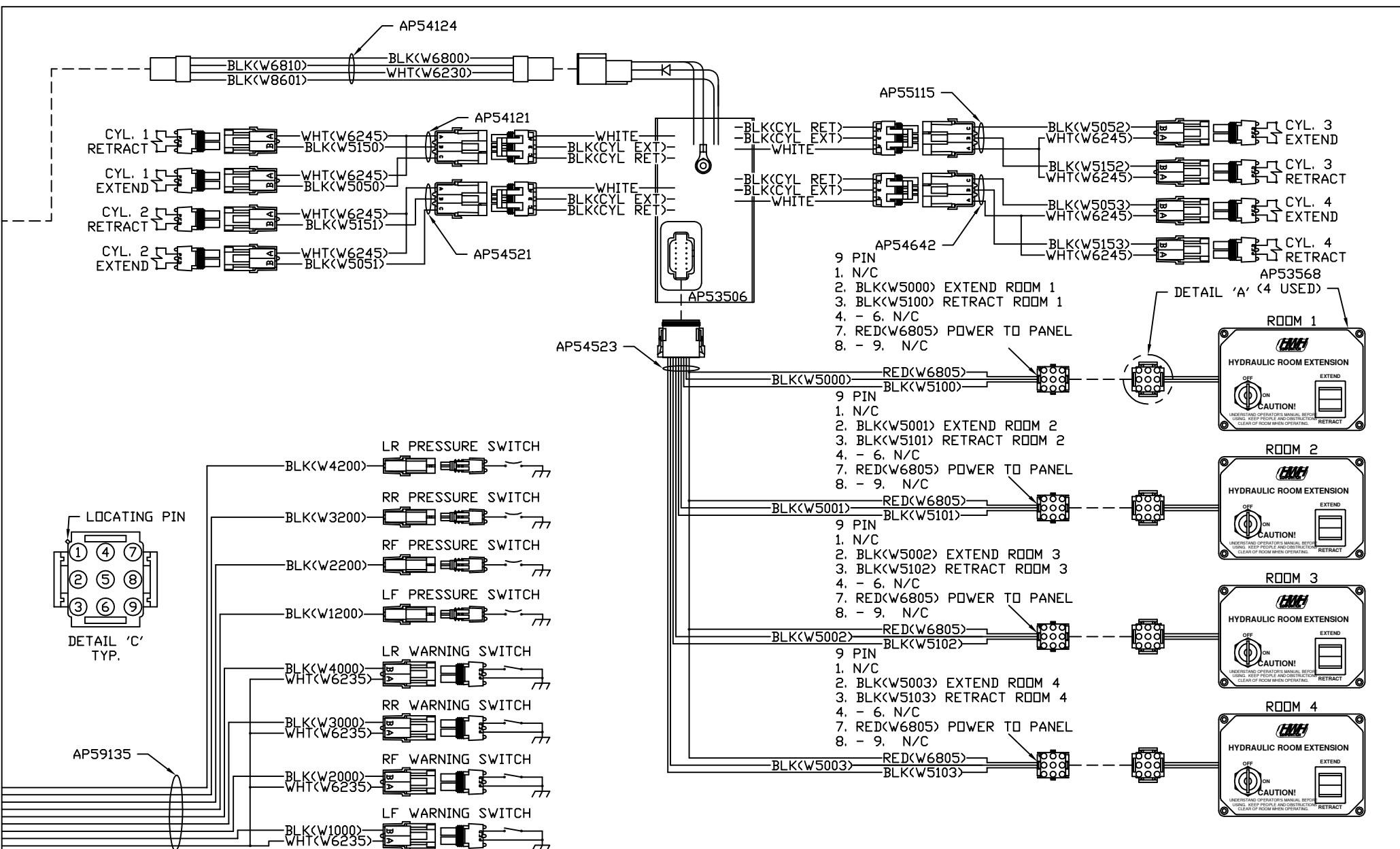

- 9 PIN
 1. N/C
 2. BLK(W5000) EXTEND ROOM 1
 3. BLK(W5100) RETRACT ROOM 1
 4. - 6. N/C
 7. RED(W6805) POWER TO PANEL
 8. - 9. N/C

- 9 PIN
 1. N/C
 2. BLK(W5001) EXTEND ROOM 2
 3. BLK(W5101) RETRACT ROOM 2
 4. - 6. N/C
 7. RED(W6805) POWER TO PANEL
 8. - 9. N/C

- 9 PIN
 1. N/C
 2. BLK(W5002) EXTEND ROOM 3
 3. BLK(W5102) RETRACT ROOM 3
 4. - 6. N/C
 7. RED(W6805) POWER TO PANEL
 8. - 9. N/C

- 9 PIN
 1. N/C
 2. BLK(W5003) EXTEND ROOM 4
 3. BLK(W5103) RETRACT ROOM 4
 4. - 6. N/C
 7. RED(W6805) POWER TO PANEL
 8. - 9. N/C

- RED(W6805)
 BLK(W5103)

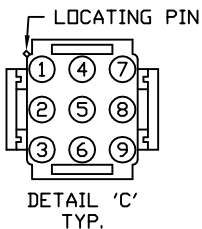

NOTE: INSTALLATION MUST CONFORM TO GOOD SHOP PRACTICES, SAE STANDARDS, RVIA STANDARDS, AND OTHER APPLICABLE STANDARDS.