

AP25801 CN1 (BLACK)
PIN
1 BLK(W7696) SYSTEM WAKE UP
2 N/C
3 RED(W6800) SW BATT
4 WHT(W6230) GROUND
5 CAN SHIELD
6 RED(W6110) IGNITION
7 GRN CAN LOW
8 YEL CAN HI

AP25801 CN10 (GRAY)
PIN
1 BLK(W7599) SWITCH LIGHT CONTROL
2 RED(W6100) RESET OUT
3 BLK(W7550) RESET IN
4 RED(W6121) WARN LIGHT SUPPLY
5 WHT(W6230) SWITCH LIGHT SUPPLY
6 BLK(W7699) WARN LIGHT/BUZZER CONTROL

AP25801 CN11 (GRAY)
PIN
1 RED(W6110) IGNITION
2 N/C
3 N/C
4 N/C
5 RED(W6120) ACCESSORY
6 RED(W6100) HOUSE BATTERY
7 WHT(W6230) GROUND
8 BLK(W9961) NEUTRAL HOLD
9 BLK(W9965) NEUTRAL HOLD
10 N/C
11 BLK(W9000) PARK BRAKE SWITCH
12 RED(W6101) ENGINE BATTERY

AP25801 CN9 (GREEN)
PIN
1 BLK(W8500) MASTER RELAY CONTROL
2 BLK(W8100) SYSTEM PSW
3 N/C
4 BLK(W8600) PMP RELAY CONTROL
5 BLK(W9900) SPEED SWITCH
6 BLK(W9901) PUMP MONITOR
7 N/C
8 N/C

AP25801 CN99 (GRAY)
PIN
1 RED (AP22693)
2 GRN (AP22693)
3 BLK (AP22693)
4 YLW (AP22693)
5 WHT (AP22693)
6 N/C
7 N/C
8 N/C

AP25948 (BROWN)
PIN
1 BLK(W5050) RM 1 CYL. EXTEND
2 BLK(W5150) RM 1 CYL. RETRACT
3 BLK(W5200) RM 1 LOCK
4 BLK(W5300) RM 1 UNLOCK
5 BLK(W5400) FLOOR UP
6 BLK(W5500) FLOOR DOWN
7 BLK(W5201) RM 2 LOCK
8 BLK(W5301) RM 2 UNLOCK
9 BLK(W5151) RM 2 CYL. RETRACT
10 BLK(W5051) RM 2 CYL. EXTEND
11 N/C
12 N/C

AP25948 (GRAY)
PIN
1 BLK(W6801) SW BATT
2 BLK(W6801) SW BATT
3 WHT(W6231) GROUND
4 WHT(W6231) GROUND

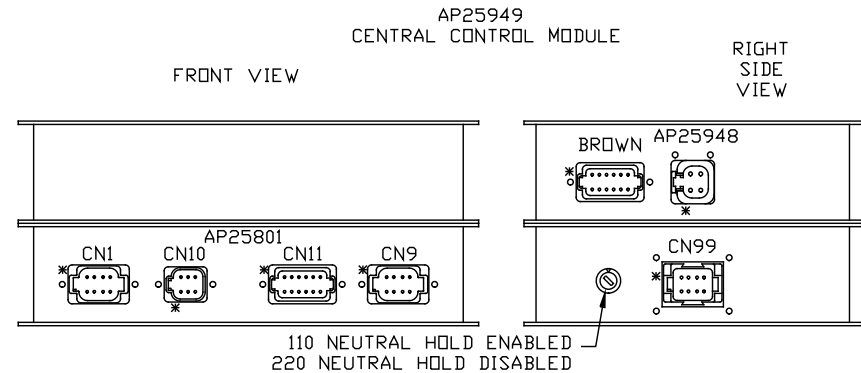

			HWH	I-80 EXIT 267 SOUTH RT 1 MOSCOW, IOWA 52760
			SCALE 1:3	DATE 01MAR05
			DRAWN BY .	
NO.	DATE	REVISION	SYSTEM SCHEMATIC ELEC	
THE INFORMATION DISCLOSED ON THIS DRAWING IS CONFIDENTIAL AND MUST NOT BE DISCLOSED OR USED IN ANY MANNER WHICH WILL BE DETRIMENTAL TO THE HWH CORPORATION			DRAWING NUMBER MP88705 A/T	

AP23320
FRONT AIR MODULE

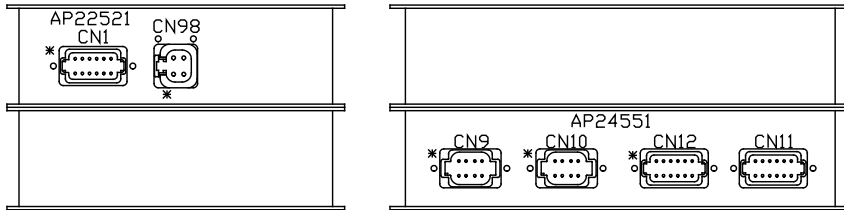

* DESIGNATES PIN 1 OF CONNECTORS

AP22521 CN1 (BROWN)
PIN

- 1 N/C
- 2 BLK(W1500) LEFT FRONT RAISE
- 3 BLK(W1600) LEFT FRONT LOWER
- 4 BLK(W2500) RIGHT FRONT RAISE
- 5 BLK(W2600) RIGHT FRONT LOWER
- 6 BLK(W9700) COMPRESSOR
- 7 N/C
- 8 BLK(W1700) FRONT TRAVEL
- 9 N/C
- 10 N/C
- 11 WHT(W6254) GROUND
- 12 N/C

CN98 (GRAY)
PIN

- 1 BLK(W6800) SW BATT
- 2 BLK(W6800) SW BATT
- 3 WHT(W6230) GROUND
- 4 WHT(W6230) GROUND

AP24551 CN9 (BLACK)
PIN

- 1 BLK(W7696) SYSTEM WAKE UP
- 2 N/C
- 3 RED(W6800) SW BATT
- 4 WHT(W6230) GROUND
- 5 CAN SHIELD
- 6 RED(W6110) IGNITION
- 7 GRN CAN LOW
- 8 YEL CAN HI

AP24551 CN10 (GRAY)
PIN

- 1 N/C
- 2 N/C
- 3 N/C
- 4 N/C
- 5 N/C
- 6 N/C
- 7 N/C
- 8 N/C

AP24551 CN12 (GRAY)
PIN

- 1 N/C
- 2 N/C
- 3 N/C
- 4 N/C
- 5 N/C
- 6 WHT(W6235) GROUND
- 7 N/C
- 8 N/C
- 9 N/C
- 10 BLK(W2210) RIGHT FRONT AIR PSW
- 11 N/C
- 12 N/C

AP24551 CN11 (GREEN)
PIN

- 1 N/C
- 2 N/C
- 3 N/C
- 4 N/C
- 5 N/C
- 6 WHT(W6236) GROUND
- 7 N/C
- 8 N/C
- 9 N/C
- 10 BLK(W1210) LEFT FRONT AIR PSW
- 11 N/C
- 12 N/C

AP23321
REAR AIR MODULE

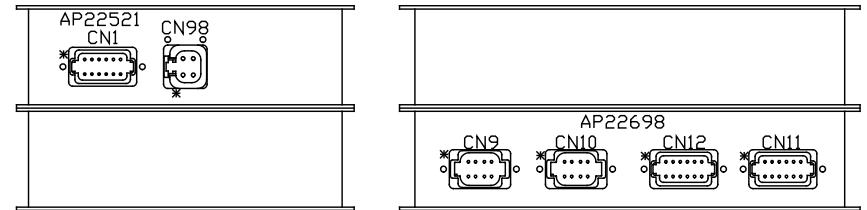

* DESIGNATES PIN 1 OF CONNECTORS

AP22521 CN1 (BROWN)
PIN

- 1 N/C
- 2 BLK(W4500) LEFT REAR RAISE
- 3 BLK(W4600) LEFT REAR LOWER
- 4 BLK(W3500) RIGHT REAR RAISE
- 5 BLK(W3600) RIGHT REAR LOWER
- 6 N/C
- 7 N/C
- 8 BLK(W3700) REAR TRAVEL
- 9 N/C
- 10 N/C
- 11 WHT(W6258) GROUND
- 12 N/C

CN98 (GRAY)
PIN

- 1 BLK(W6800) SW BATT
- 2 BLK(W6800) SW BATT
- 3 WHT(W6230) GROUND
- 4 WHT(W6230) GROUND

AP22698 CN9 (BLACK)
PIN

- 1 BLK(W7696) SYSTEM WAKE UP
- 2 N/C
- 3 RED(W6800) SW BATT
- 4 WHT(W6230) GROUND
- 5 CAN SHIELD
- 6 RED(W6110) IGNITION
- 7 GRN CAN LOW
- 8 YEL CAN HI

AP22698 CN10 (GRAY)
PIN

- 1 N/C
- 2 N/C
- 3 N/C
- 4 N/C
- 5 N/C
- 6 N/C
- 7 N/C
- 8 N/C

AP22698 CN12 (GRAY)
PIN

- 1 N/C
- 2 N/C
- 3 BLK(W3215) AIR SYSTEM PSW
- 4 N/C
- 5 N/C
- 6 WHT(W6235) GROUND
- 7 N/C
- 8 N/C
- 9 N/C
- 10 N/C
- 11 N/C
- 12 N/C

AP22698 CN11 (GREEN)
PIN

- 1 N/C
- 2 N/C
- 3 N/C
- 4 N/C
- 5 N/C
- 6 N/C
- 7 N/C
- 8 N/C
- 9 N/C
- 10 N/C
- 11 N/C
- 12 N/C

AP22695 CN1 (BROWN)

PIN
 1 N/C
 2 AIR SEAL (OEM)
 3 N/C
 4 N/C
 5 N/C
 6 N/C
 7 N/C
 8 N/C
 9 N/C
 10 N/C
 11 GROUND (OEM)
 12 N/C

CN98 (GRAY)

PIN
 1 BLK(W6800) SW BATT
 2 BLK(W6800) SW BATT
 3 WHT(W6230) GROUND
 4 WHT(W6230) GROUND

AP22694 CN9 (BLACK)

PIN
 1 BLK(W7696) SYSTEM WAKE UP
 2 N/C
 3 RED(W6800) SW BATT
 4 WHT(W6230) GROUND
 5 CAN SHIELD
 6 RED(W6110) IGNITION
 7 GRN CAN LOW
 8 YEL CAN HI

AP22694 CN10 (GRAY)

PIN
 1 N/C
 2 BLK(W7510) READY TO OPERATE
 3 BLK(W7530) PUMP
 4 BLK(W7501) EXTEND (ROOM 1)
 5 BLK(W7502) RETRACT (ROOM 1)
 6 RED(W6805) SW BATTERY
 7 BLK(W7696) SYSTEM WAKE UP
 8 WHT(W6230) GROUND

AP22694 CN12 (GRAY)

PIN
 1 N/C
 2 FRONT ROOM OUT (OEM)
 3 LOWER FRONT ROOM IN (OEM)
 4 N/C
 5 FLOOR DOWN (OEM)
 6 GROUND (OEM)
 7 SWITCHED BATTERY (OEM)
 8 FLOOR UP (OEM)
 9 UPPER FRONT LOCK (OEM)
 10 UPPER FRONT ROOM IN (OEM)
 11 N/C
 12 UPPER FRONT UNLOCK (OEM)

AP22694 CN 11 (GREEN)

PIN
 1 N/C
 2 REAR ROOM OUT (OEM)
 3 LOWER REAR ROOM IN (OEM)
 4 N/C
 5 N/C
 6 GROUND (OEM)
 7 SWITCHED BATTERY (OEM)
 8 N/C
 9 UPPER REAR LOCK (OEM)
 10 UPPER REAR ROOM IN (OEM)
 11 N/C
 12 UPPER REAR UNLOCK (OEM)

AP23316
 ROOM 1 MODULE

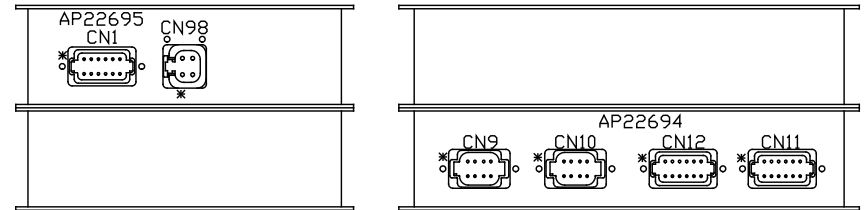

* DESIGNATES PIN 1 OF CONNECTORS

AP22695 CN1 (BROWN)
PIN
1 N/C
2 AIR SEAL (OEM)
3 N/C
4 N/C
5 N/C
6 N/C
7 N/C
8 N/C
9 N/C
10 N/C
11 GROUND (OEM)
12 N/C

CN98 (GRAY)
PIN
1 BLK(W6800) SW BATT
2 BLK(W6800) SW BATT
3 WHT(W6230) GROUND
4 WHT(W6230) GROUND

AP22694 CN9 (BLACK)
PIN
1 BLK(W7696) SYSTEM WAKE UP
2 N/C
3 RED(W6800) SW BATT
4 WHT(W6230) GROUND
5 CAN SHIELD
6 RED(W6110) IGNITION
7 GRN CAN LOW
8 YEL CAN HI

AP22694 CN10 (GRAY)
PIN
1 N/C
2 BLK(W7510) READY TO OPERATE
3 BLK(W7530) PUMP
4 BLK(W7501) EXTEND (ROOM 2)
5 BLK(W7502) RETRACT (ROOM 2)
6 RED(W6805) SW BATTERY
7 BLK(W7696) SYSTEM WAKE UP
8 WHT(W6230) GROUND

AP22694 CN12 (GRAY)
PIN
1 N/C
2 FRONT ROOM OUT (OEM)
3 LOWER FRONT ROOM IN (OEM)
4 N/C
5 N/C
6 GROUND (OEM)
7 SWITCHED BATTERY (OEM)
8 N/C
9 UPPER FRONT LOCK (OEM)
10 UPPER FRONT ROOM IN (OEM)
11 N/C
12 UPPER FRONT UNLOCK (OEM)

AP22694 CN 11 (GREEN))
PIN
1 N/C
2 REAR ROOM OUT (OEM)
3 LOWER REAR ROOM IN (OEM)
4 N/C
5 N/C
6 GROUND (OEM)
7 SWITCHED BATTERY (OEM)
8 N/C
9 UPPER REAR LOCK (OEM)
10 UPPER REAR ROOM IN (OEM)
11 N/C
12 UPPER REAR UNLOCK (OEM)

AP23317
ROOM 2 MODULE

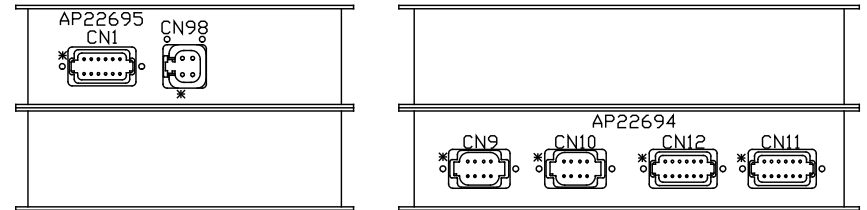

* DESIGNATES PIN 1 OF CONNECTORS

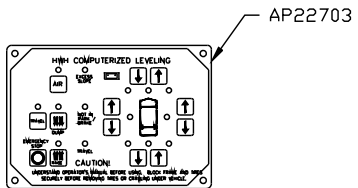

- PIN
- 1 YELLOW CAN HI
 - 2 GREEN CAN LOW
 - 3 CAN SHIELD
 - 4 WHT(W6230) GROUND
 - 5 BLK(W6800) SW. BATTERY

120 OHM
TERMINATION
RESISTOR
PART OF AP25950

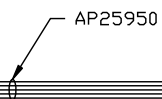
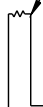

TO SILVER LEAF INTERFACE.



- <BLACK>
PIN
- 1 BLK(W7696) SYSTEM WAKE UP
 - 2 N/C
 - 3 RED(W6800) SW BATT
 - 4 WHT(W6230) GND
 - 5 CAN SHIELD
 - 6 RED(W6110) IGNITION
 - 7 GRN CAN LOW
 - 8 YEL CAN HI

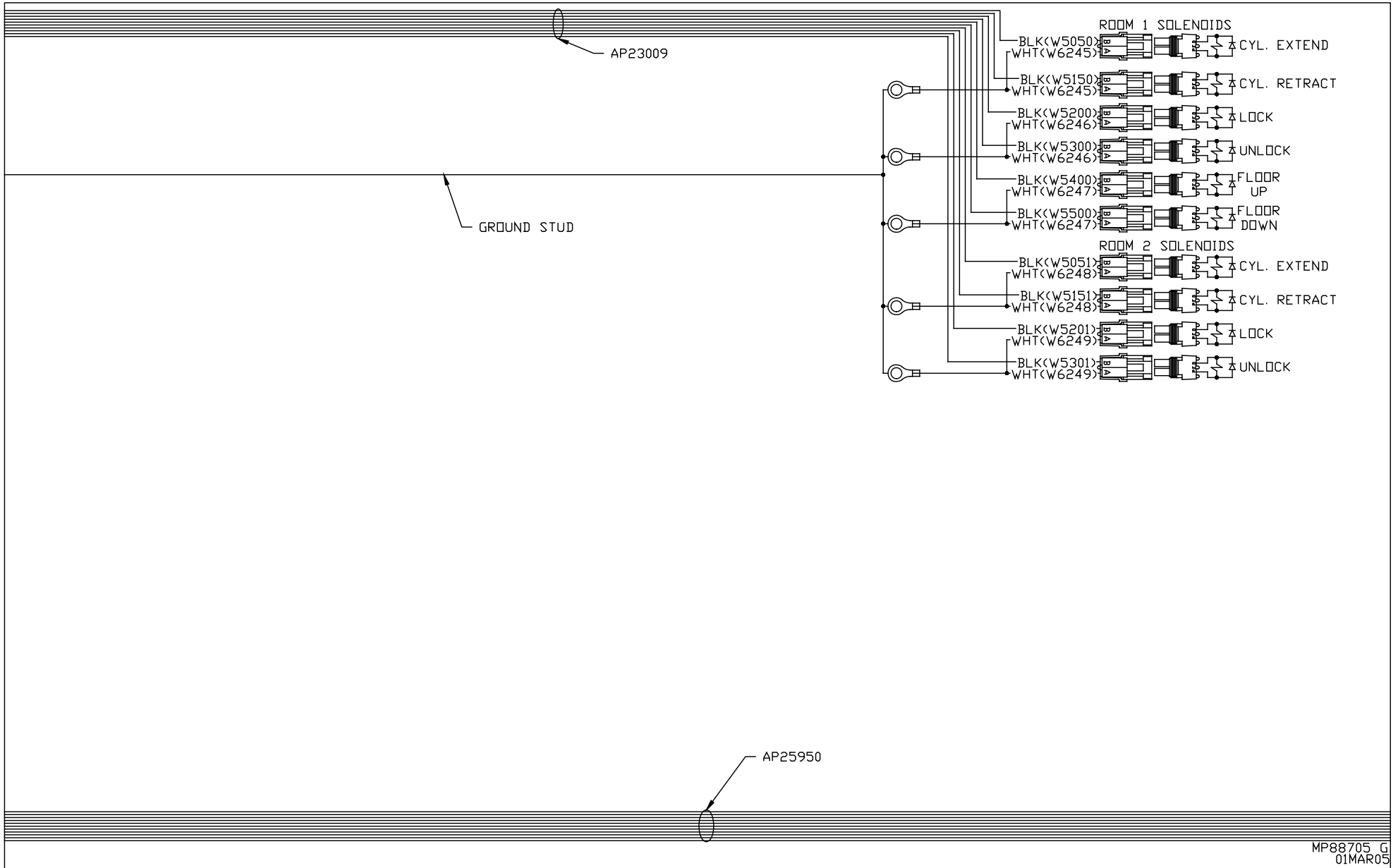

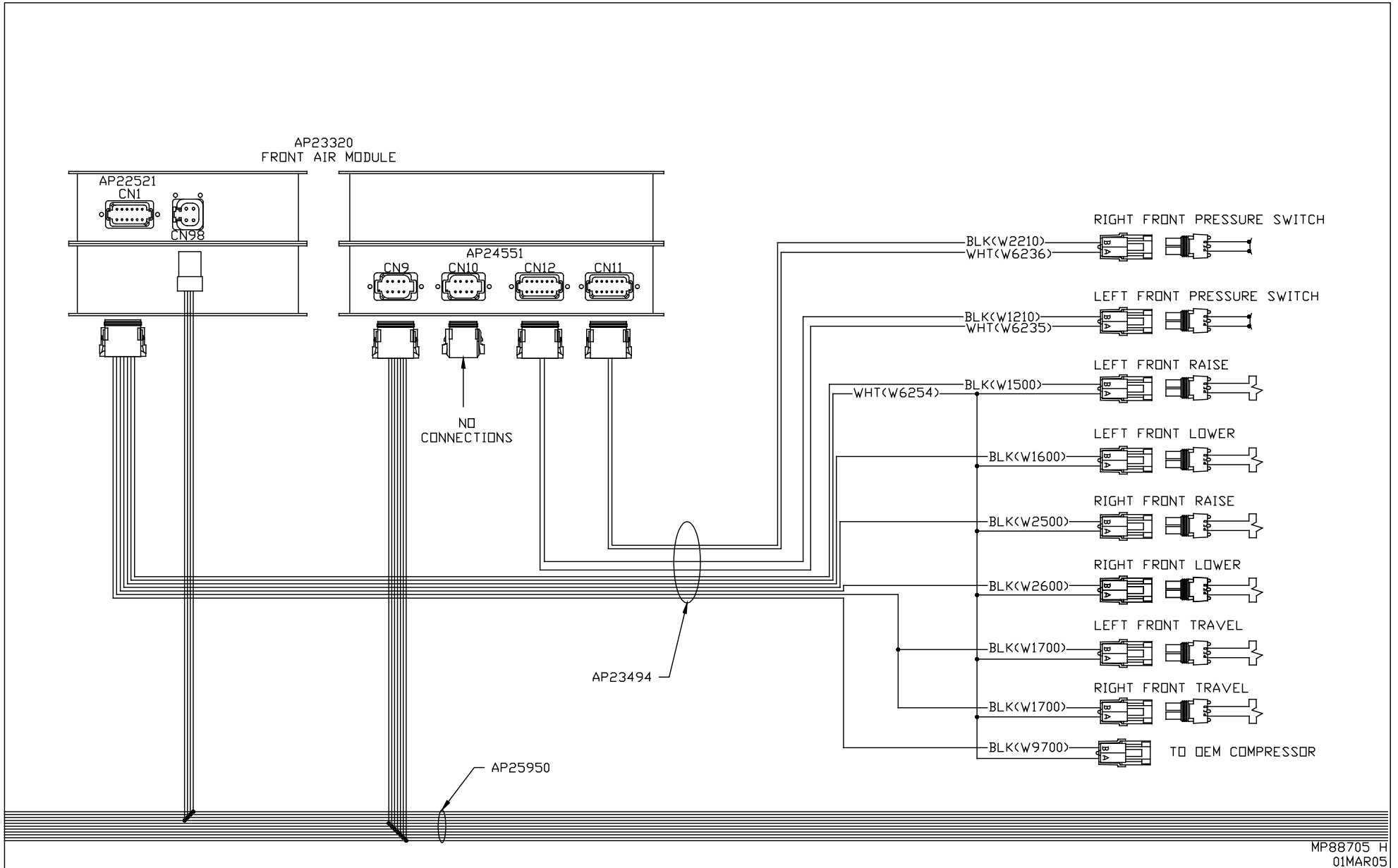

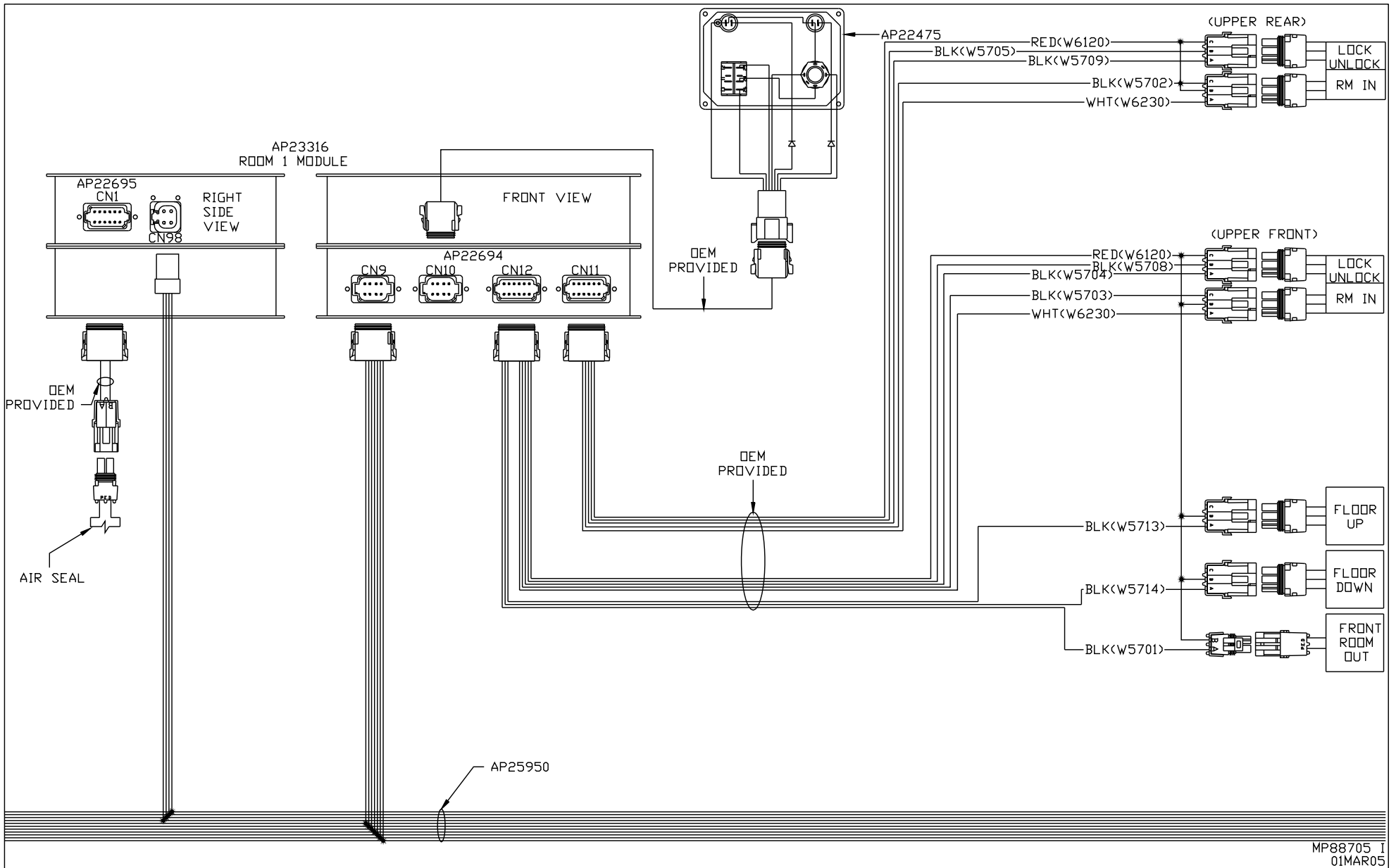

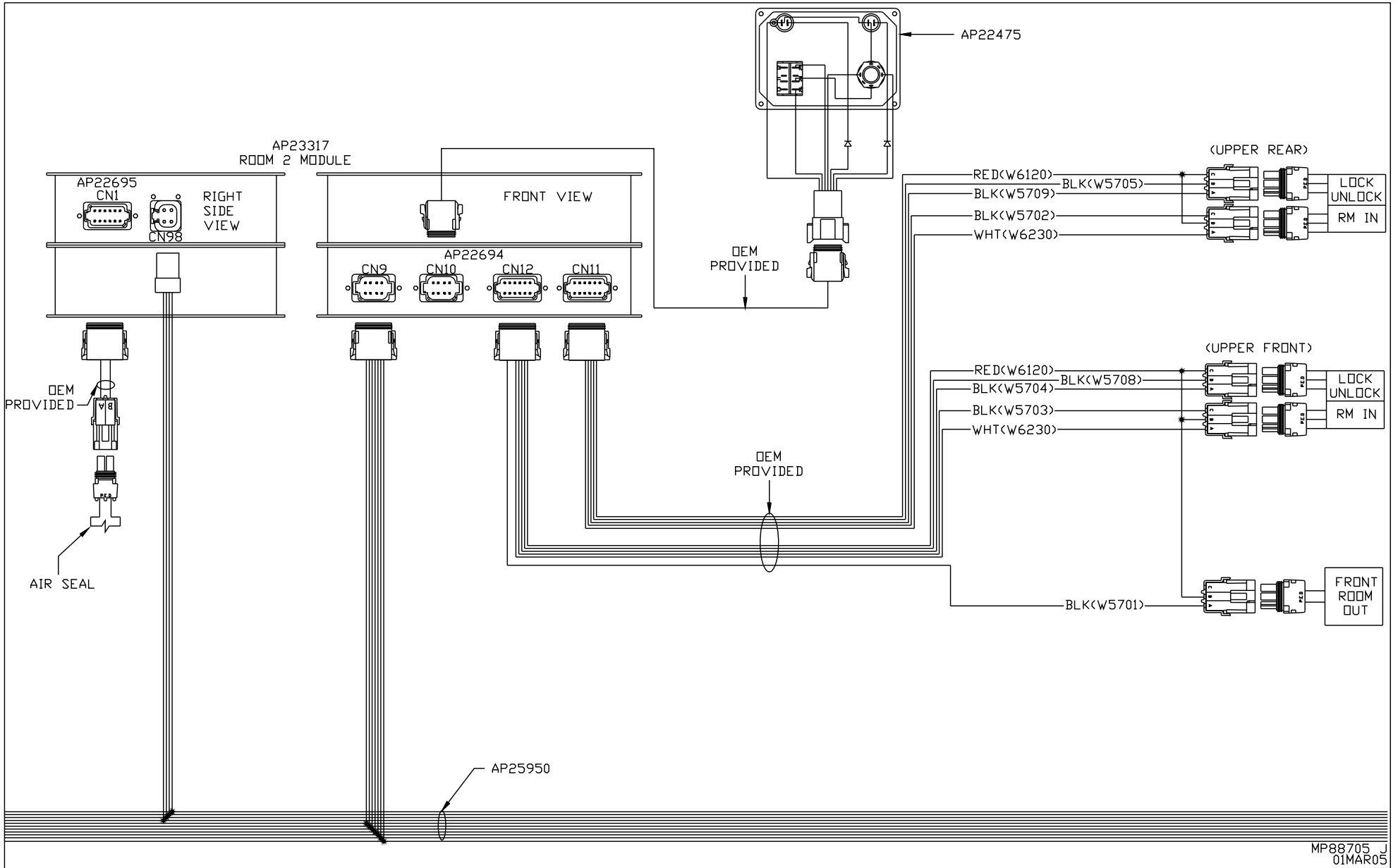

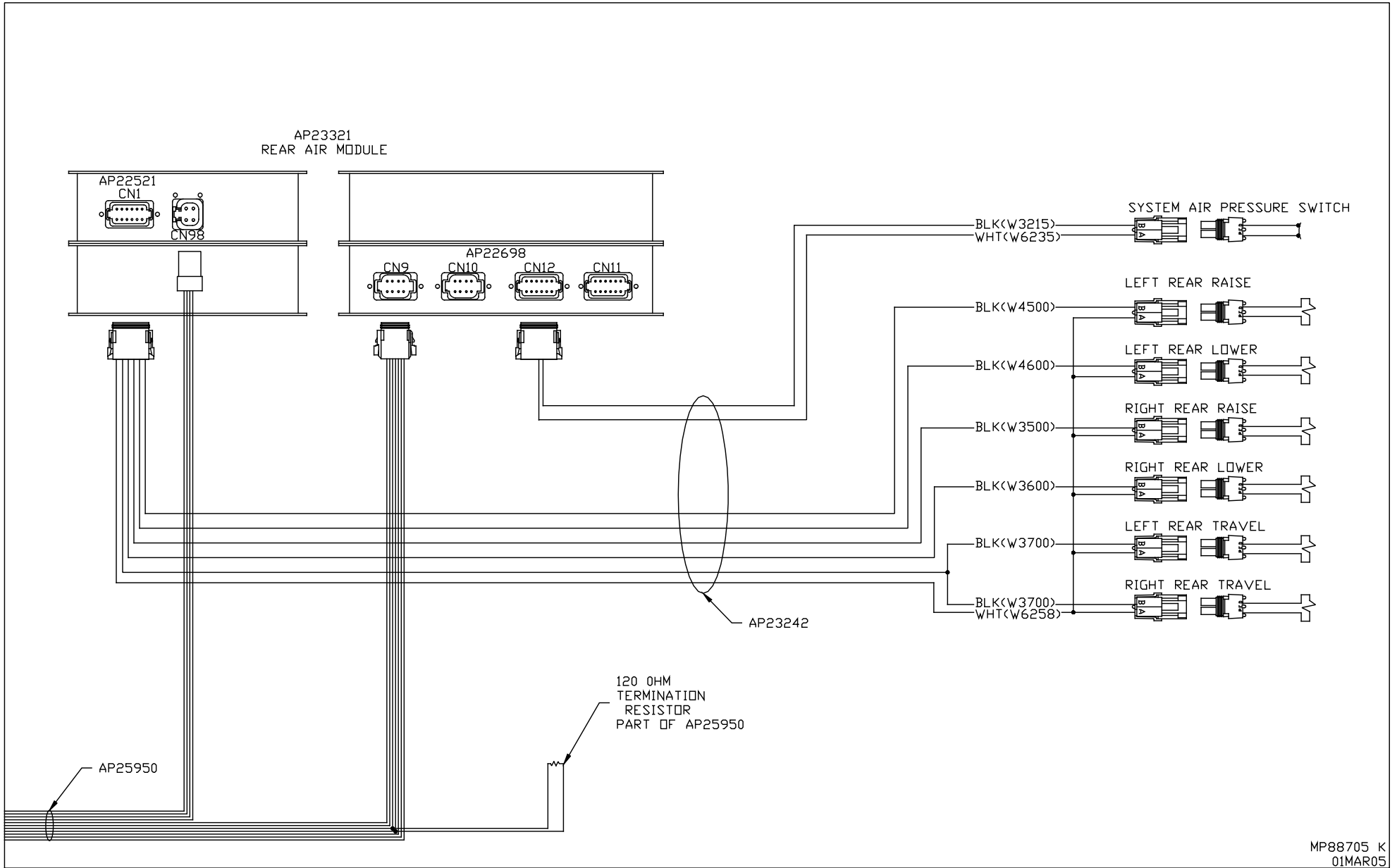

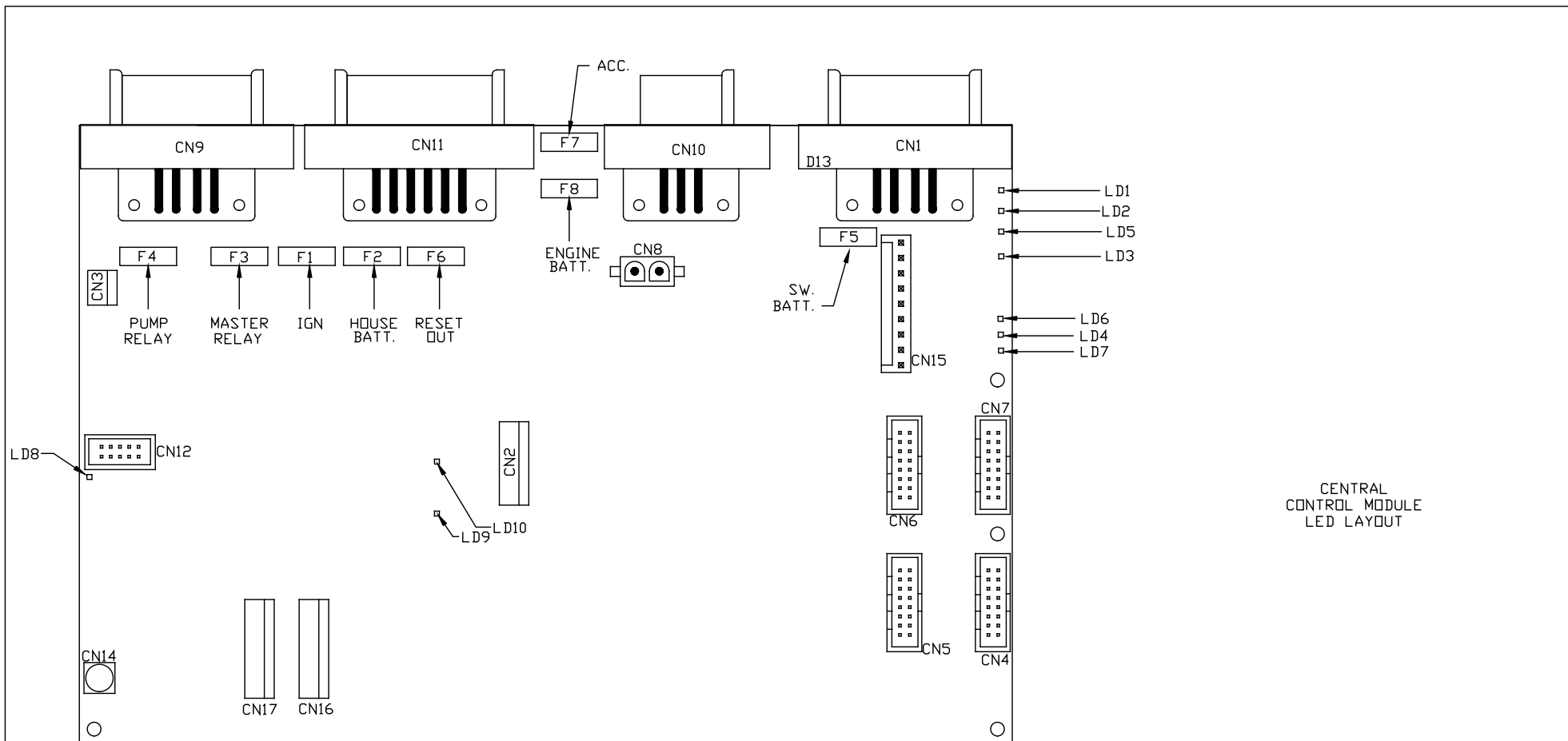

CENTRAL
CONTROL MODULE
LED LAYOUT

LED #	CONNECTOR	COLOR	DESCRIPTION
LED 1	CN 9 PIN 1	RED	MASTER RELAY
LED 2	CN 9 PIN 4	RED	PUMP RELAY
LED 3	CN 1 PIN 3	RED	SW 12V
LED 4	CN 11 PIN 12	RED	ENGINE BATT
LED 5	CN 9 PIN 5	RED	SPEED SWITCH
LED 6	NOT USED	NOT USED	NOT USED
LED 7	CN 1 PIN 7 & 8	RED	LINK LIGHT
LED 8	CN 11 PIN 8 & 9	RED	NEUTRAL HOLD
LED 9	NOT USED	NOT USED	NOT USED
LED 10	CN9 PIN 2	RED	3000 LBS. PSW

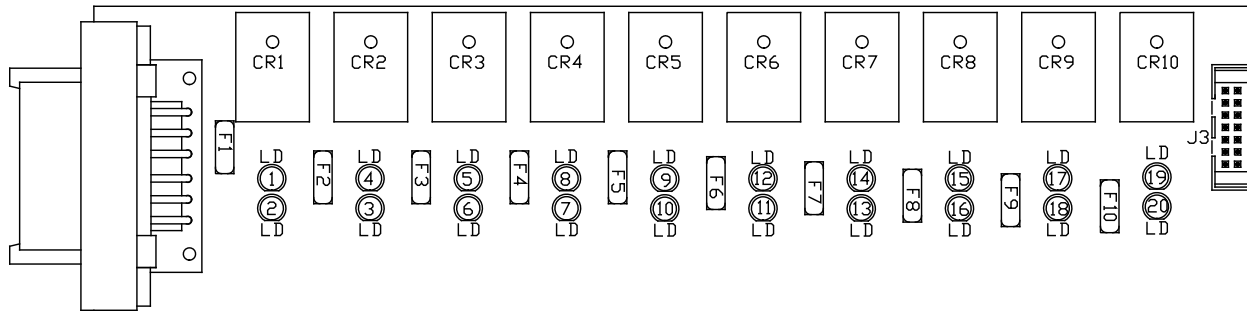

LED #	COLOR	INPUT J3	FUSE #	OUTPUT	RELAY #	DESCRIPTION
LED1	YELLOW	PIN 13	---	---	CR1	EXTEND CYL. RM 1 <COIL>
LED2	RED	---	FUSE 1	PIN 1	CR1	EXTEND CYL. RM 1 <CONTACT>
LED3	RED	---	FUSE 2	PIN 2	CR2	RETRACT CYL. RM 1 <CONTACT>
LED4	YELLOW	PIN 12	---	---	CR2	RETRACT CYL. RM 1 <COIL>
LED5	YELLOW	PIN 11	---	---	CR3	LOCK RM 1 <COIL>
LED6	RED	---	FUSE 3	PIN 3	CR3	LOCK RM 1 <CONTACT>
LED7	RED	---	FUSE 4	PIN 4	CR4	UNLOCK RM 1 <CONTACT>
LED8	YELLOW	PIN 10	---	---	CR4	UNLOCK RM 1 <COIL>
LED9	YELLOW	PIN 9	---	---	CR5	RM 1 FLOOR UP <COIL>
LED10	RED	---	FUSE 5	PIN 5	CR5	RM 1 FLOOR UP <CONTACT>
LED11	RED	---	FUSE 6	PIN 6	CR6	RM 1 FLOOR DOWN <CONTACT>
LED12	YELLOW	PIN 8	---	---	CR6	RM 1 FLOOR DOWN <COIL>
LED13	RED	---	FUSE 7	PIN 10	CR7	EXTEND CYL. RM 2 <CONTACT>
LED14	YELLOW	PIN 7	---	---	CR7	EXTEND CYL. RM 2 <COIL>
LED15	YELLOW	PIN 6	---	---	CR8	RETRACT CYL. RM 2 <COIL>
LED16	RED	---	FUSE8	PIN 9	CR8	RETRACT CYL. RM 2 <CONTACT>
LED17	YELLOW	PIN 5	---	---	CR9	LOCK RM 2 <COIL>
LED18	RED	---	FUSE 9	PIN 7	CR9	LOCK RM 2 <CONTACT>
LED19	YELLOW	PIN 4	---	---	CR10	UNLOCK RM 2 <COIL>
LED20	RED	---	FUSE 10	PIN 8	CR10	UNLOCK RM 2 <CONTACT>

ROOM 1 AND ROOM 2
HYDRAULIC OUTPUT
LED LAYOUT

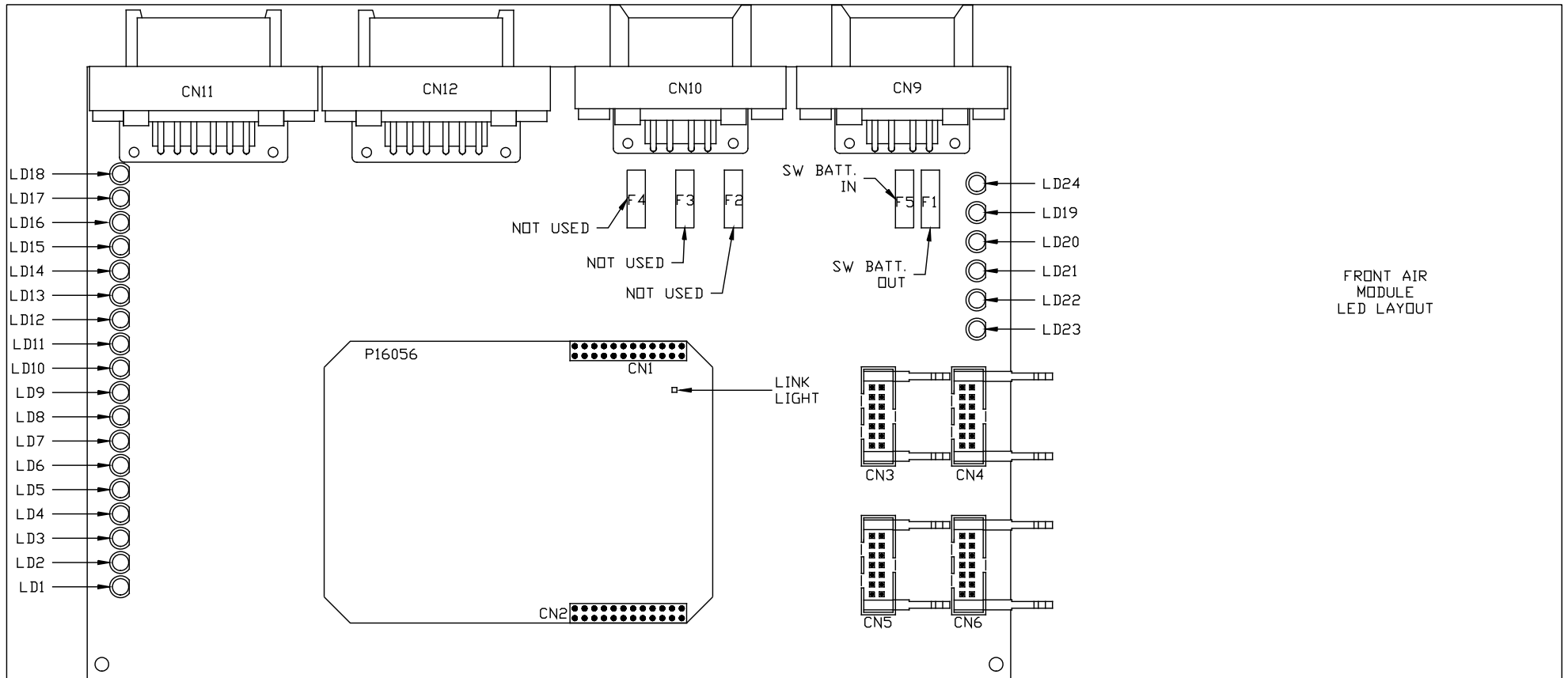

FRONT AIR
MODULE
LED LAYOUT

LED #	CONNECTOR	COLOR	DESCRIPTION
LED 1	NOT USED	RED	NOT USED
LED 2	NOT USED	RED	NOT USED
LED 3	NOT USED	GREEN	NOT USED
LED 4	NOT USED	YELLOW	NOT USED
LED 5	NOT USED	YELLOW	NOT USED
LED 6	NOT USED	YELLOW	NOT USED
LED 7	NOT USED	GREEN	NOT USED
LED 8	NOT USED	GREEN	NOT USED
LED 9	CN 11 PIN 10	GREEN	LEFT FRONT PSW
LED 10	CN 12 PIN 10	GREEN	RIGHT FRONT PSW
LED 11	NOT USED	YELLOW	NOT USED
LED 12	NOT USED	YELLOW	NOT USED
LED 13	NOT USED	YELLOW	NOT USED
LED 14	NOT USED	YELLOW	NOT USED

LED #	CONNECTOR	COLOR	DESCRIPTION
LED 15	NOT USED	GREEN	NOT USED
LED 16	NOT USED	GREEN	NOT USED
LED 17	NOT USED	GREEN	NOT USED
LED 18	NOT USED	GREEN	NOT USED
LED 19	NOT USED	RED	SW BATT OUT
LED 20	NOT USED	RED	SW BATT IN
LED 21	NOT USED	RED	NOT USED
LED 22	NOT USED	RED	NOT USED
LED 23	NOT USED	RED	NOT USED
LED 24	NOT USED	RED	NOT USED
LED 25	---	---	---
LED 26	---	---	---
LED 27	---	---	---
LED 28	---	---	---

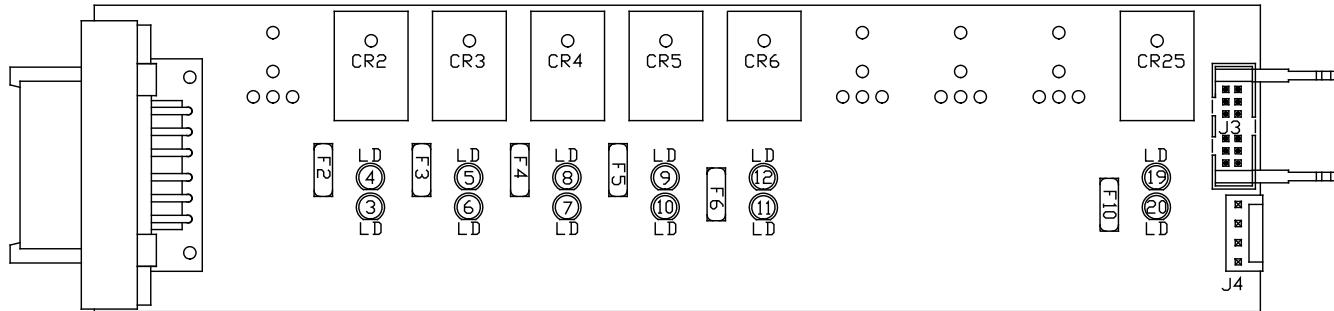

FRONT AIR OUTPUTS
LED LAYOUT

LED #	COLOR	INPUT J3	FUSE #	OUTPUT	RELAY #	DESCRIPTION
LED1	---	---	---	---	---	---
LED2	---	---	---	---	---	---
LED3	RED	---	FUSE 2	PIN 2	CR2	LEFT RAISE (CONTACT)
LED4	YELLOW	PIN 12	---	---	CR2	LEFT RAISE (COIL)
LED5	YELLOW	PIN 11	---	---	CR3	LEFT LOWER (COIL)
LED6	RED	---	FUSE 3	PIN 3	CR3	LEFT LOWER (CONTACT)
LED7	RED	---	FUSE 4	PIN 4	CR4	RIGHT RAISE (CONTACT)
LED8	YELLOW	PIN 10	---	---	CR4	RIGHT RAISE (COIL)
LED9	YELLOW	PIN 9	---	---	CR5	RIGHT LOWER (COIL)
LED10	RED	---	FUSE 5	PIN 5	CR5	RIGHT LOWER (CONTACT)
LED11	RED	---	FUSE 6	PIN 6	CR6	COMPRESSOR (CONTACT)
LED12	YELLOW	PIN 8	---	---	CR6	COMPRESSOR (COIL)
LED13	---	---	---	---	---	---
LED14	---	---	---	---	---	---
LED15	---	---	---	---	---	---
LED16	---	---	---	---	---	---
LED17	---	---	---	---	---	---
LED18	---	---	---	---	---	---
LED19	YELLOW	PIN 4	---	---	CR25	TRAVEL (COIL)
LED20	RED	---	FUSE 10	PIN 8	CR25	TRAVEL (CONTACT)

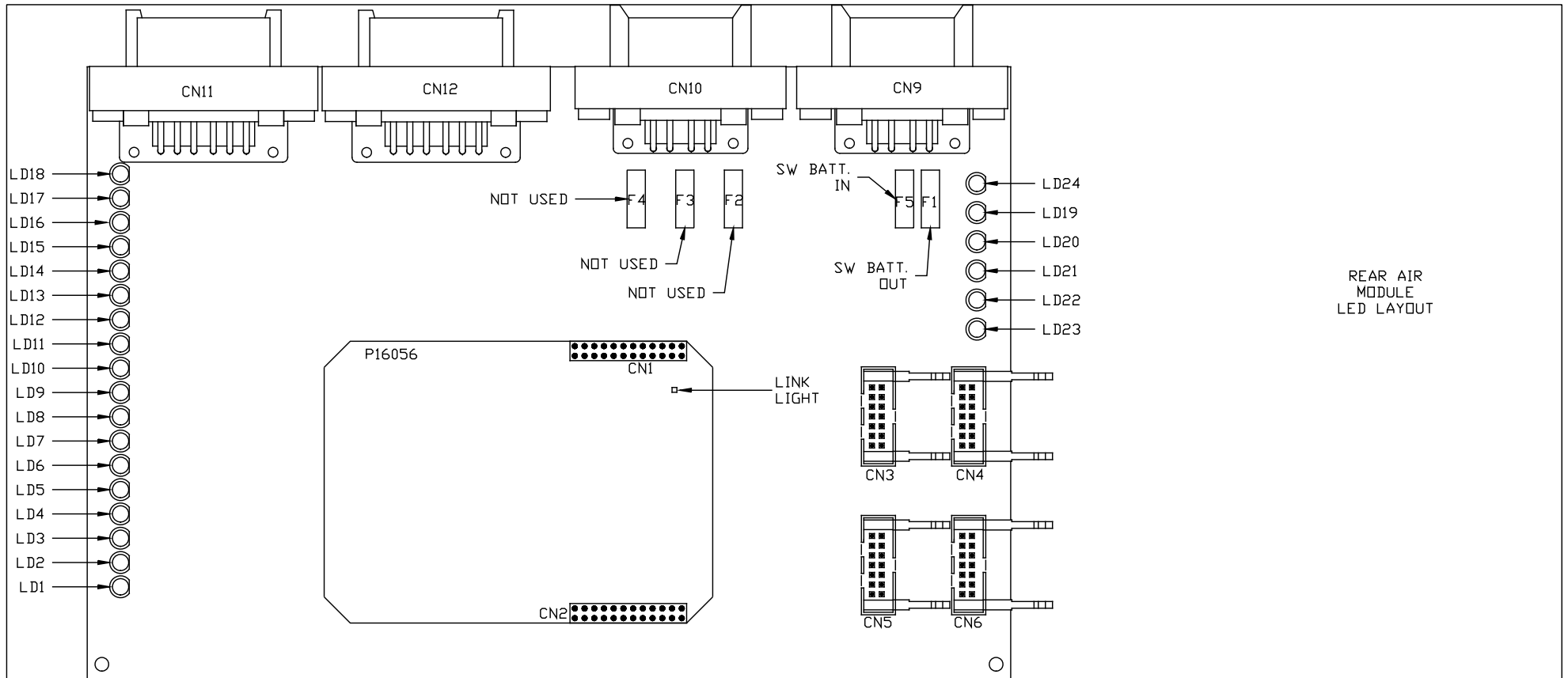

LED #	CONNECTOR	COLOR	DESCRIPTION
LED 1	NOT USED	RED	NOT USED
LED 2	NOT USED	RED	NOT USED
LED 3	NOT USED	GREEN	NOT USED
LED 4	NOT USED	YELLOW	NOT USED
LED 5	NOT USED	YELLOW	NOT USED
LED 6	NOT USED	YELLOW	NOT USED
LED 7	NOT USED	GREEN	NOT USED
LED 8	CN 12 PIN 3	GREEN	SYSTEM PRESS SW
LED 9	NOT USED	GREEN	NOT USED
LED 10	NOT USED	GREEN	NOT USED
LED 11	NOT USED	YELLOW	NOT USED
LED 12	NOT USED	YELLOW	NOT USED
LED 13	NOT USED	YELLOW	NOT USED
LED 14	NOT USED	YELLOW	NOT USED

LED #	CONNECTOR	COLOR	DESCRIPTION
LED 15	NOT USED	GREEN	NOT USED
LED 16	NOT USED	GREEN	NOT USED
LED 17	NOT USED	GREEN	NOT USED
LED 18	NOT USED	GREEN	NOT USED
LED 19	NOT USED	RED	SW BATT OUT
LED 20	NOT USED	RED	SW BATT IN
LED 21	NOT USED	RED	NOT USED
LED 22	NOT USED	RED	NOT USED
LED 23	NOT USED	RED	NOT USED
LED 24	NOT USED	RED	NOT USED
LED 25	---	---	---
LED 26	---	---	---
LED 27	---	---	---
LED 28	---	---	---

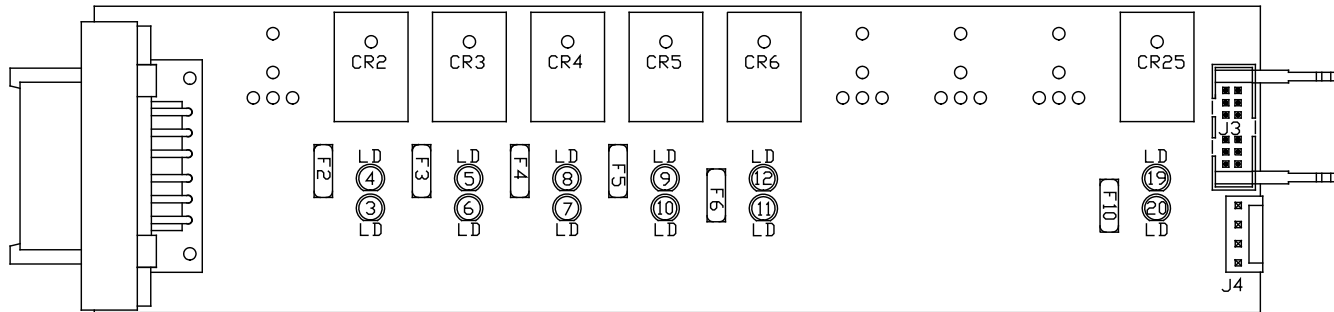

REAR AIR OUTPUTS
LED LAYOUT

LED #	COLOR	INPUT J3	FUSE #	OUTPUT	RELAY #	DESCRIPTION
LED1	---	---	---	---	---	---
LED2	---	---	---	---	---	---
LED3	RED	---	FUSE 2	PIN 2	CR2	LEFT RAISE (CONTACT)
LED4	YELLOW	PIN 12	---	---	CR2	LEFT RAISE (COIL)
LED5	YELLOW	PIN 11	---	---	CR3	LEFT LOWER (COIL)
LED6	RED	---	FUSE 3	PIN 3	CR3	LEFT LOWER (CONTACT)
LED7	RED	---	FUSE 4	PIN 4	CR4	RIGHT RAISE (CONTACT)
LED8	YELLOW	PIN 10	---	---	CR4	RIGHT RAISE (COIL)
LED9	YELLOW	PIN 9	---	---	CR5	RIGHT LOWER (COIL)
LED10	RED	---	FUSE 5	PIN 5	CR5	RIGHT LOWER (CONTACT)
LED11	RED	---	FUSE 6	PIN 6	CR6	COMPRESSOR (CONTACT)
LED12	YELLOW	PIN 8	---	---	CR6	COMPRESSOR (COIL)
LED13	---	---	---	---	---	---
LED14	---	---	---	---	---	---
LED15	---	---	---	---	---	---
LED16	---	---	---	---	---	---
LED17	---	---	---	---	---	---
LED18	---	---	---	---	---	---
LED19	YELLOW	PIN 4	---	---	CR25	TRAVEL (COIL)
LED20	RED	---	FUSE 10	PIN 8	CR25	TRAVEL (CONTACT)

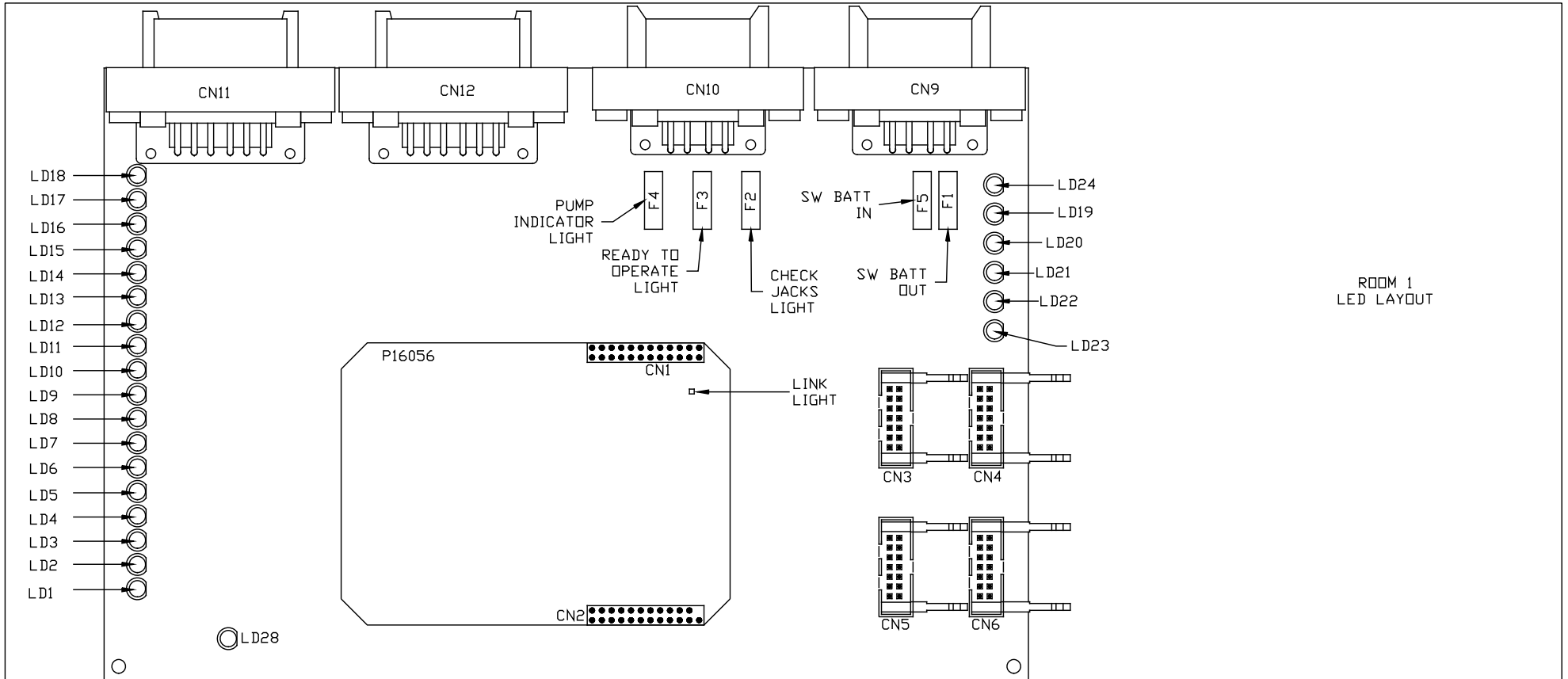

ROOM 1
LED LAYOUT

LED #	CONNECTOR	COLOR	DESCRIPTION	LED #	CONNECTOR	COLOR	DESCRIPTION
LED 1	NOT USED	RED	NOT USED	LED 15	CN 11 PIN 4	GREEN	LR LOCK
LED 2	NOT USED	RED	NOT USED	LED 16	CN 12 PIN 4	GREEN	LF LOCK
LED 3	CN12 PIN 8	GREEN	FLOOR UP	LED 17	CN 11 PIN 9	GREEN	UR LOCK
LED 4	CN12 PIN 5	YELLOW	FLOOR DOWN	LED 18	CN 12 PIN 9	GREEN	UF LOCK
LED 5	NOT USED	YELLOW	NOT USED	LED 19	CN11/CN12 PIN 7	RED	SW 12V
LED 6	CN 12 PIN 2	YELLOW	FRONT RM OUT	LED 20	CN9 PIN 3	RED	SW BATT
LED 7	NOT USED	GREEN	NOT USED	LED 21	CN10 PIN 3	RED	PUMP INDICATOR
LED 8	NOT USED	GREEN	NOT USED	LED 22	CN10 PIN 2	RED	READY TO OPERATE
LED 9	CN 11 PIN 10	GREEN	UR ROOM IN	LED 23	NOT USED	RED	NOT USED
LED 10	CN 12 PIN 10	GREEN	UF ROOM IN	LED 24	CN 10 PIN 7	RED	SYSTEM WAKE UP
LED 11	CN 11 PIN 1	YELLOW	LR UNLOCK	LED 25	---	---	---
LED 12	CN 12 PIN 1	YELLOW	LF UNLOCK	LED 26	---	---	---
LED 13	CN11 PIN 12	YELLOW	UR UNLOCK	LED 27	---	---	---
LED 14	CN 12 PIN 12	YELLOW	UF UNLOCK	LED 28	NOT USED	RED	NOT USED

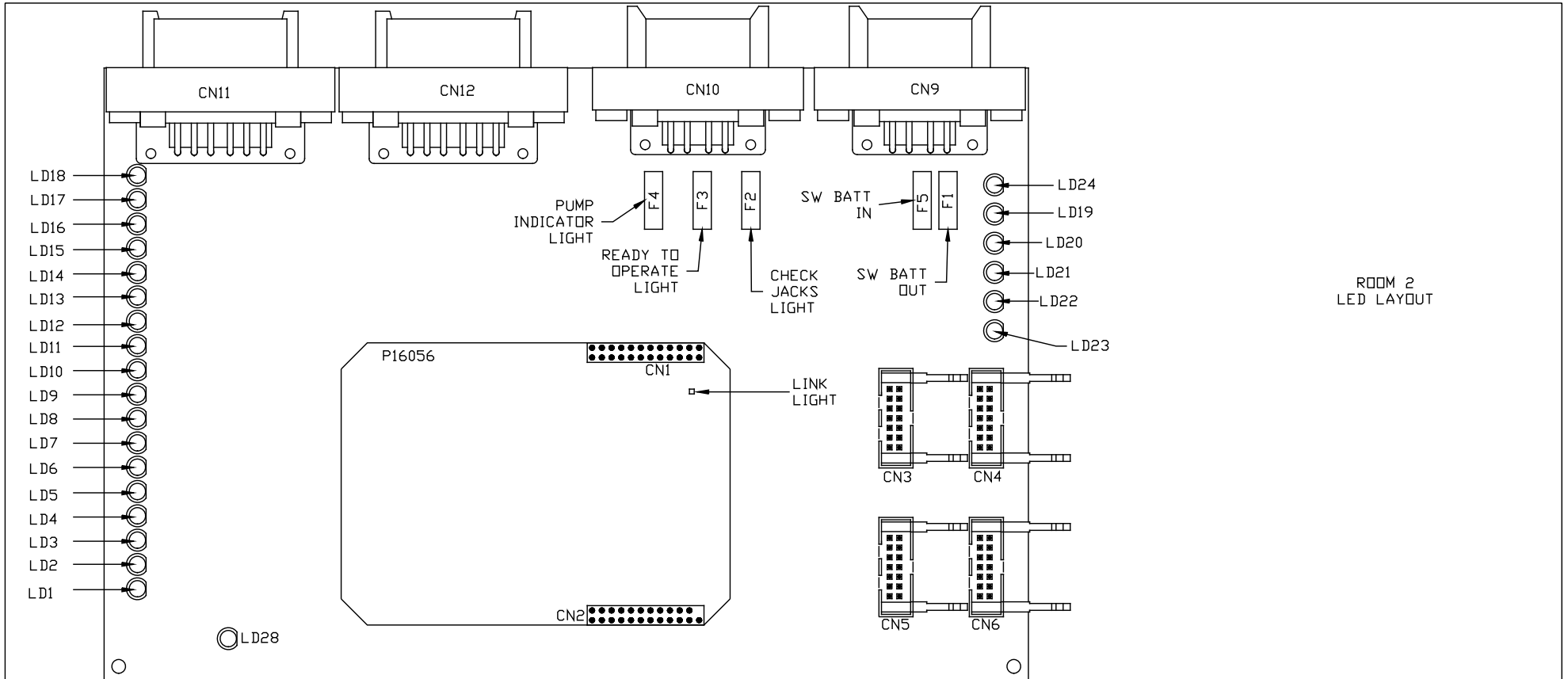

ROOM 2
LED LAYOUT

LED #	CONNECTOR	COLOR	DESCRIPTION	LED #	CONNECTOR	COLOR	DESCRIPTION
LED 1	NOT USED	RED	NOT USED	LED 15	CN 11 PIN 4	GREEN	LR LOCK
LED 2	NOT USED	RED	NOT USED	LED 16	CN 12 PIN 4	GREEN	LF LOCK
LED 3	NOT USED	GREEN	NOT USED	LED 17	CN 11 PIN 9	GREEN	UR LOCK
LED 4	NOT USED	YELLOW	NOT USED	LED 18	CN 12 PIN 9	GREEN	UF LOCK
LED 5	NOT USED	YELLOW	NOT USED	LED 19	CN11/CN12 PIN 7	RED	SW 12V
LED 6	CN 12 PIN 2	YELLOW	FRONT RM OUT	LED 20	CN9 PIN 3	RED	SW BATT
LED 7	NOT USED	GREEN	NOT USED	LED 21	CN10 PIN 3	RED	PUMP INDICATOR
LED 8	NOT USED	GREEN	NOT USED	LED 22	CN10 PIN 2	RED	READY TO OPERATE
LED 9	CN 11 PIN 10	GREEN	UR ROOM IN	LED 23	NOT USED	RED	NOT USED
LED 10	CN 12 PIN 10	GREEN	UF ROOM IN	LED 24	CN 10 PIN 7	RED	SYSTEM WAKE UP
LED 11	CN 11 PIN 1	YELLOW	LR UNLOCK	LED 25	---	---	---
LED 12	CN 12 PIN 1	YELLOW	LF UNLOCK	LED 26	---	---	---
LED 13	CN11 PIN 12	YELLOW	UR UNLOCK	LED 27	---	---	---
LED 14	CN 12 PIN 12	YELLOW	UF UNLOCK	LED 28	NOT USED	RED	NOT USED

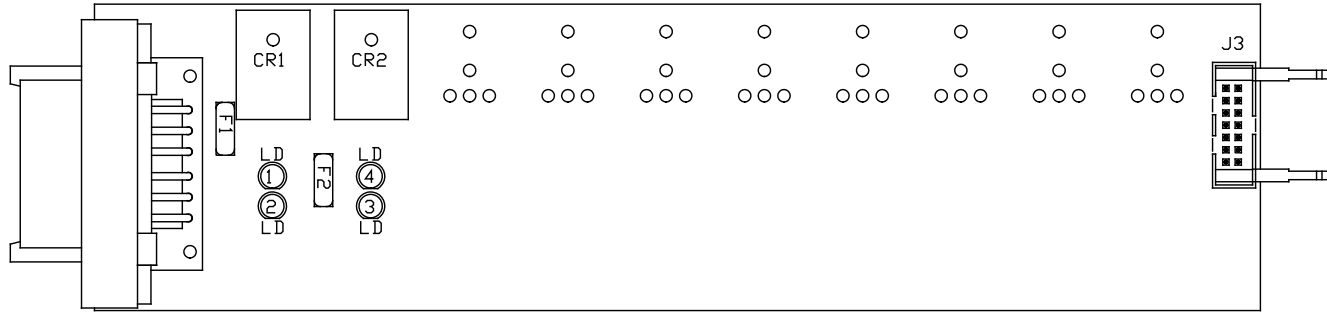

LED #	COLOR	INPUT J3	FUSE #	OUTPUT	RELAY #	DESCRIPTION
LED1	YELLOW	PIN 13	---	---	CR1	AIR SEAL (COIL)
LED2	RED	---	FUSE 1	PIN 1	CR1	AIR SEAL (CONTACT)
LED3	RED	---	FUSE 2	PIN 2	CR2	VACUUM (CONTACT)
LED4	YELLOW	PIN 12	---	---	CR2	VACUUM (COIL)
LED5	---	---	---	---	---	---
LED6	---	---	---	---	---	---
LED7	---	---	---	---	---	---
LED8	---	---	---	---	---	---
LED9	---	---	---	---	---	---
LED10	---	---	---	---	---	---
LED11	---	---	---	---	---	---
LED12	---	---	---	---	---	---
LED13	---	---	---	---	---	---
LED14	---	---	---	---	---	---
LED15	---	---	---	---	---	---
LED16	---	---	---	---	---	---
LED17	---	---	---	---	---	---
LED18	---	---	---	---	---	---
LED19	---	---	---	---	---	---
LED20	---	---	---	---	---	---

ROOM 1
OUTPUT
LED LAYOUT
(ROOM 2 IS SIMILAR)