

AP25801 CNI (BLACK)
PIN
1 BLK(W7696) SYSTEM WAKE UP
2 N/C
3 RED(W6800) SW BATT
4 WHT(W6230) GROUND
5 CAN SHIELD
6 RED(W6110) IGNITION
7 GRN CAN LOW
8 YEL CAN HI

AP25801 CN10 (GRAY)
PIN
1 BLK(W7599) SWITCH LIGHT CONTROL
2 RED(W6100) RESET OUT
3 BLK(W7550) RESET IN
4 RED(W6121) WARN LIGHT SUPPLY
5 WHT(W6230) SWITCH LIGHT SUPPLY
6 BLK(W7699) WARN LIGHT/BUZZER CONTROL

AP25801 CN11 (GRAY)
PIN
1 RED(W6110) IGNITION
2 N/C
3 N/C
4 N/C
5 RED(W6120) ACCESSORY
6 RED(W6100) HOUSE BATTERY
7 WHT(W6230) GROUND
8 BLK(W9961) NEUTRAL HOLD
9 BLK(W9965) NEUTRAL HOLD
10 N/C
11 BLK(W9000) PARK BRAKE SWITCH
12 RED(W6101) ENGINE BATTERY

AP25801 CN9 (GREEN)
PIN
1 BLK(W8500) MASTER RELAY CONTROL
2 BLK(W8100) SYSTEM PSW
3 N/C
4 BLK(W8600) PMP RELAY CONTROL
5 BLK(W9900) SPEED SWITCH
6 BLK(W9901) PUMP MONITOR
7 N/C
8 N/C

AP25801 CN99 (GRAY)
PIN
1 RED (AP22693)
2 GRN (AP22693)
3 BLK (AP22693)
4 YLW (AP22693)
5 WHT (AP22693)
6 N/C
7 N/C
8 N/C

AP25804 (BROWN)
PIN
1 BLK(W5050) RM 1 CYL. EXTEND
2 BLK(W5150) RM 1 CYL. RETRACT
3 BLK(W5200) RM 1 LOCK
4 BLK(W5300) RM 1 UNLOCK
5 BLK(W5400) FLOOR UP
6 BLK(W5500) FLOOR DOWN
7 BLK(W5201) RM 2 LOCK
8 BLK(W5301) RM 2 UNLOCK
9 BLK(W5151) RM 2 CYL. RETRACT
10 BLK(W5051) RM 2 CYL. EXTEND
11 N/C
12 N/C

AP25804 (GRAY)
PIN
1 BLK(W6801) SW BATT
2 BLK(W6801) SW BATT
3 WHT(W6231) GROUND
4 WHT(W6231) GROUND

AP25804 (BLACK)
PIN
1 BLK(W5050) RM 3 CYL. EXTEND
2 BLK(W5150) RM 3 CYL. RETRACT
3 BLK(W5200) RM 3 LOCK
4 BLK(W5300) RM 3 UNLOCK
5 NOT USED
6 NOT USED
7 BLK(W5201) RM 4 LOCK
8 BLK(W5301) RM 4 UNLOCK
9 BLK(W5151) RM 4 CYL. RETRACT
10 BLK(W5051) RM 4 CYL. EXTEND
11 N/C
12 N/C

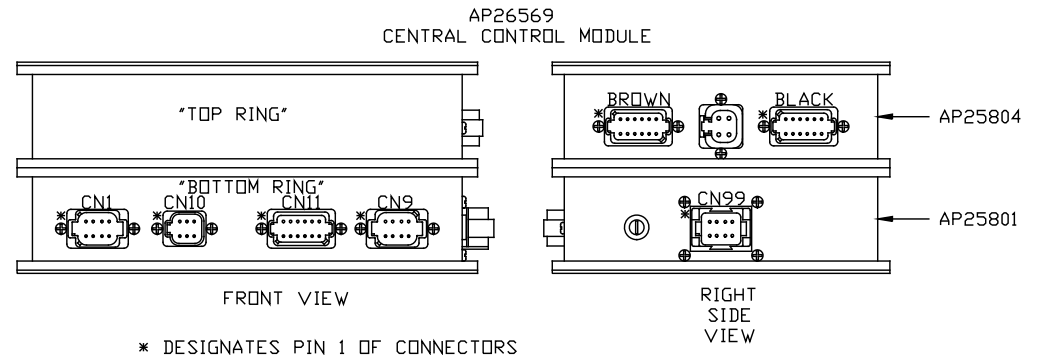

		HWH I-80 EXIT 267 SOUTH RT 1 MOSCOW, IOWA 52760	
		SCALE 1:3	DATE 01MAR05
		DRAWN BY .	
		SYSTEM SCHEMATIC ELEC	
NO.	DATE	REVISION	
THE INFORMATION DISCLOSED ON THIS DRAWING IS CONFIDENTIAL AND MUST NOT BE DISCLOSED OR USED IN ANY MANNER WHICH WILL BE DETRIMENTAL TO THE HWH CORPORATION		DRAWING NUMBER MP88776 A/Z	

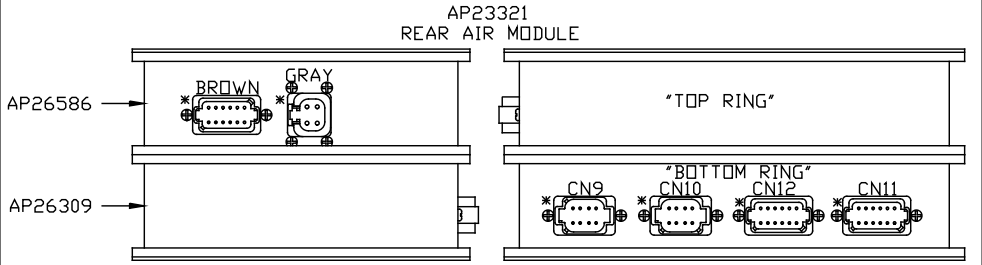
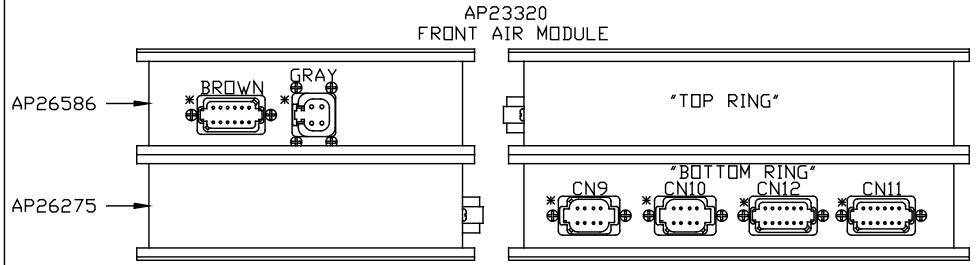

* DESIGNATES PIN 1 OF CONNECTORS

* DESIGNATES PIN 1 OF CONNECTORS

- AP26586 (BROWN)
PIN
- 1 N/C
 - 2 BLK(W1500) LEFT FRONT RAISE
 - 3 BLK(W1600) LEFT FRONT LOWER
 - 4 BLK(W2500) RIGHT FRONT RAISE
 - 5 BLK(W2600) RIGHT FRONT LOWER
 - 6 BLK(W9700) COMPRESSOR
 - 7 N/C
 - 8 BLK(W1700) FRONT TRAVEL
 - 9 N/C
 - 10 N/C
 - 11 WHT(W6254) GROUND
 - 12 N/C

- AP26586 (GRAY)
PIN
- 1 BLK(W6801) SW BATT
 - 2 BLK(W6801) SW BATT
 - 3 WHT(W6231) GROUND
 - 4 WHT(W6231) GROUND

- AP26275 CN9 (BLACK)
PIN
- 1 BLK(W7696) SYSTEM WAKE UP
 - 2 N/C
 - 3 RED(W6800) SW BATT
 - 4 WHT(W6230) GROUND
 - 5 CAN SHIELD
 - 6 RED(W6110) IGNITION
 - 7 GRN CAN LOW
 - 8 YEL CAN HI

- AP26275 CN10 (GRAY)
PIN
- 1 N/C
 - 2 N/C
 - 3 N/C
 - 4 N/C
 - 5 N/C
 - 6 N/C
 - 7 N/C
 - 8 N/C

- AP26275 CN12 (GRAY)
PIN
- 1 N/C
 - 2 N/C
 - 3 N/C
 - 4 N/C
 - 5 N/C
 - 6 WHT(W6235) GROUND
 - 7 N/C
 - 8 N/C
 - 9 N/C
 - 10 BLK(W2210) RIGHT FRONT AIR PSW
 - 11 N/C
 - 12 N/C

- AP26275 CN11 (GREEN)
PIN
- 1 N/C
 - 2 N/C
 - 3 N/C
 - 4 N/C
 - 5 N/C
 - 6 WHT(W6236) GROUND
 - 7 N/C
 - 8 N/C
 - 9 N/C
 - 10 BLK(W1210) LEFT FRONT AIR PSW
 - 11 N/C
 - 12 N/C

- AP26586 (BROWN)
PIN
- 1 N/C
 - 2 BLK(W4500) LEFT REAR RAISE
 - 3 BLK(W4600) LEFT REAR LOWER
 - 4 BLK(W3500) RIGHT REAR RAISE
 - 5 BLK(W3600) RIGHT REAR LOWER
 - 6 N/C
 - 7 N/C
 - 8 BLK(W3700) REAR TRAVEL
 - 9 N/C
 - 10 N/C
 - 11 WHT(W6258) GROUND
 - 12 N/C

- AP26586 (GRAY)
PIN
- 1 BLK(W6801) SW BATT
 - 2 BLK(W6801) SW BATT
 - 3 WHT(W6231) GROUND
 - 4 WHT(W6231) GROUND

- AP26309 CN9 (BLACK)
PIN
- 1 BLK(W7696) SYSTEM WAKE UP
 - 2 N/C
 - 3 RED(W6800) SW BATT
 - 4 WHT(W6230) GROUND
 - 5 CAN SHIELD
 - 6 RED(W6110) IGNITION
 - 7 GRN CAN LOW
 - 8 YEL CAN HI

- AP26309 CN10 (GRAY)
PIN
- 1 N/C
 - 2 N/C
 - 3 N/C
 - 4 N/C
 - 5 N/C
 - 6 N/C
 - 7 N/C
 - 8 N/C

- AP26309 CN12 (GRAY)
PIN
- 1 N/C
 - 2 N/C
 - 3 BLK(W3215) AIR SYSTEM PSW
 - 4 N/C
 - 5 N/C
 - 6 WHT(W6235) GROUND
 - 7 N/C
 - 8 N/C
 - 9 N/C
 - 10 N/C
 - 11 N/C
 - 12 N/C

- AP26309 CN11 (GREEN)
PIN
- 1 N/C
 - 2 N/C
 - 3 N/C
 - 4 N/C
 - 5 N/C
 - 6 N/C
 - 7 N/C
 - 8 N/C
 - 9 N/C
 - 10 N/C
 - 11 N/C
 - 12 N/C

AP26272 GRAY OEM PROVIDED
PIN

- 1 BLK(W5650) AIR SEAL
- 2 N/C
- 3 BLK(W5651) VACUUM
- 4 N/C

AP26272 CN9 (BLACK)
PIN

- 1 BLK(W7696) SYSTEM WAKE UP
- 2 N/C
- 3 RED(W6800) SW BATT
- 4 WHT(W6230) GROUND
- 5 CAN SHIELD
- 6 RED(W6110) IGNITION
- 7 GRN CAN LOW
- 8 YEL CAN HI

AP26272 CN10 (GRAY) OEM PROVIDED
PIN

- 1 N/C
- 2 READY TO OPERATE
- 3 PUMP
- 4 EXTEND (ROOM 1)
- 5 RETRACT (ROOM 1)
- 6 SW BATTERY
- 7 SYSTEM WAKE UP
- 8 GROUND

AP26272 CN12 (GRAY) OEM PROVIDED
PIN

- 1 N/C
- 2 FRONT ROOM OUT
- 3 N/C
- 4 N/C
- 5 FLOOR DOWN
- 6 GROUND
- 7 SWITCHED BATTERY
- 8 FLOOR UP
- 9 UPPER FRONT LOCK
- 10 UPPER FRONT ROOM IN
- 11 N/C
- 12 UPPER FRONT UNLOCK

AP26272 CN 11 (GREEN) OEM PROVIDED
PIN

- 1 N/C
- 2 N/C
- 3 N/C
- 4 N/C
- 5 N/C
- 6 GROUND
- 7 SWITCHED BATTERY
- 8 N/C
- 9 UPPER REAR LOCK
- 10 UPPER REAR ROOM IN
- 11 N/C
- 12 UPPER REAR UNLOCK

AP23316
ROOM 1 MODULE

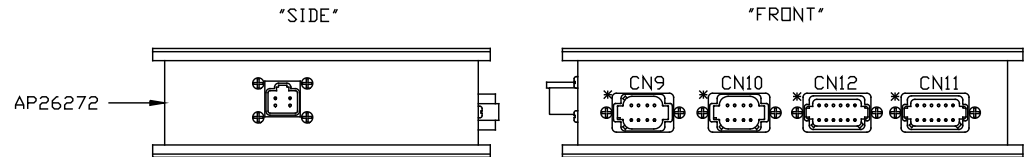

AP26272 GRAY OEM PROVIDED
PIN

- 1 BLK(W5650) AIR SEAL
- 2 N/C
- 3 BLK(W5651) VACUUM
- 4 N/C

AP26272 CN9 (BLACK)
PIN

- 1 BLK(W7696) SYSTEM WAKE UP
- 2 N/C
- 3 RED(W6800) SW BATT
- 4 WHT(W6230) GROUND
- 5 CAN SHIELD
- 6 RED(W6110) IGNITION
- 7 GRN CAN LOW
- 8 YEL CAN HI

AP26272 CN10 (GRAY) OEM PROVIDED
PIN

- 1 N/C
- 2 READY TO OPERATE
- 3 PUMP
- 4 EXTEND (ROOM 2)
- 5 RETRACT (ROOM 2)
- 6 SW BATTERY
- 7 SYSTEM WAKE UP
- 8 GROUND

AP26272 CN12 (GRAY) OEM PROVIDED
PIN

- 1 N/C
- 2 FRONT ROOM OUT
- 3 N/C
- 4 N/C
- 5 N/C
- 6 GROUND
- 7 SWITCHED BATTERY
- 8 N/C
- 9 UPPER FRONT LOCK
- 10 UPPER FRONT ROOM IN
- 11 N/C
- 12 UPPER FRONT UNLOCK

AP26272 CN 11 (GREEN) OEM PROVIDED
PIN

- 1 N/C
- 2 N/C
- 3 N/C
- 4 N/C
- 5 N/C
- 6 GROUND
- 7 SWITCHED BATTERY
- 8 N/C
- 9 UPPER REAR LOCK
- 10 UPPER REAR ROOM IN
- 11 N/C
- 12 UPPER REAR UNLOCK

AP23317
ROOM 2 MODULE

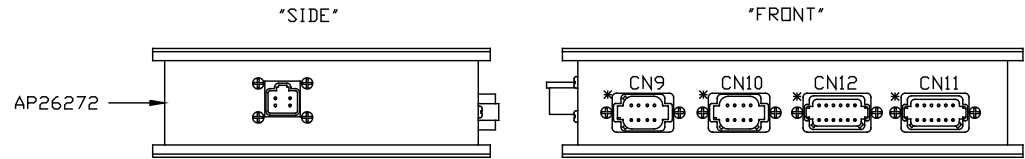

AP26273 GRAY OEM PROVIDED
PIN

- 1 BLK(W5650) AIR SEAL
- 2 N/C
- 3 BLK(W5651) VACUUM
- 4 N/C

AP26273 CN9 (BLACK)
PIN

- 1 BLK(W7696) SYSTEM WAKE UP
- 2 N/C
- 3 RED(W6800) SW BATT
- 4 WHT(W6230) GROUND
- 5 CAN SHIELD
- 6 RED(W6110) IGNITION
- 7 GRN CAN LOW
- 8 YEL CAN HI

AP26273 CN10 (GRAY) OEM PROVIDED
PIN

- 1 N/C
- 2 READY TO OPERATE
- 3 PUMP
- 4 EXTEND (ROOM 3)
- 5 RETRACT (ROOM 3)
- 6 SW BATTERY
- 7 SYSTEM WAKE UP
- 8 GROUND

AP26273 CN12 (GRAY) OEM PROVIDED
PIN

- 1 N/C
- 2 FRONT ROOM OUT
- 3 N/C
- 4 N/C
- 5 N/C
- 6 GROUND
- 7 SWITCHED BATTERY
- 8 N/C
- 9 UPPER FRONT LOCK
- 10 UPPER FRONT ROOM IN
- 11 N/C
- 12 UPPER FRONT UNLOCK

AP26273 CN 11 (GREEN) OEM PROVIDED
PIN

- 1 N/C
- 2 N/C
- 3 N/C
- 4 N/C
- 5 N/C
- 6 GROUND
- 7 SWITCHED BATTERY
- 8 N/C
- 9 UPPER REAR LOCK
- 10 UPPER REAR ROOM IN
- 11 N/C
- 12 UPPER REAR UNLOCK

AP24783
ROOM 3 MODULE

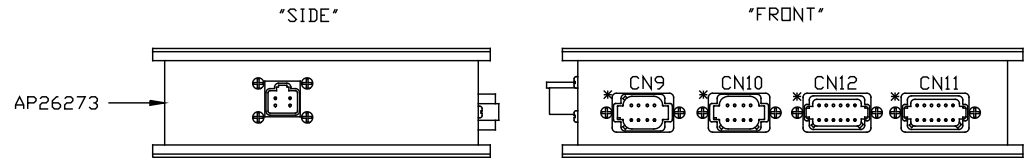

AP26273 GRAY OEM PROVIDED
PIN

- 1 BLK(W5650) AIR SEAL
- 2 N/C
- 3 BLK(W5651) VACUUM
- 4 N/C

AP26273 CN9 (BLACK)
PIN

- 1 BLK(W7696) SYSTEM WAKE UP
- 2 N/C
- 3 RED(W6800) SW BATT
- 4 WHT(W6230) GROUND
- 5 CAN SHIELD
- 6 RED(W6110) IGNITION
- 7 GRN CAN LOW
- 8 YEL CAN HI

AP26273 CN10 (GRAY) OEM PROVIDED
PIN

- 1 N/C
- 2 READY TO OPERATE
- 3 PUMP
- 4 EXTEND (ROOM 4)
- 5 RETRACT (ROOM 4)
- 6 SW BATTERY
- 7 SYSTEM WAKE UP
- 8 GROUND

AP26273 CN12 (GRAY) OEM PROVIDED
PIN

- 1 N/C
- 2 FRONT ROOM OUT
- 3 N/C
- 4 N/C
- 5 N/C
- 6 GROUND
- 7 SWITCHED BATTERY
- 8 N/C
- 9 UPPER FRONT LOCK
- 10 UPPER FRONT ROOM IN
- 11 PSW SYNCH CYLINDER
- 12 UPPER FRONT UNLOCK

AP26273 CN 11 (GREEN) OEM PROVIDED
PIN

- 1 N/C
- 2 N/C
- 3 N/C
- 4 N/C
- 5 N/C
- 6 GROUND
- 7 SWITCHED BATTERY
- 8 N/C
- 9 UPPER REAR LOCK
- 10 UPPER REAR ROOM IN
- 11 N/C
- 12 UPPER REAR UNLOCK

AP24467
ROOM 4 MODULE

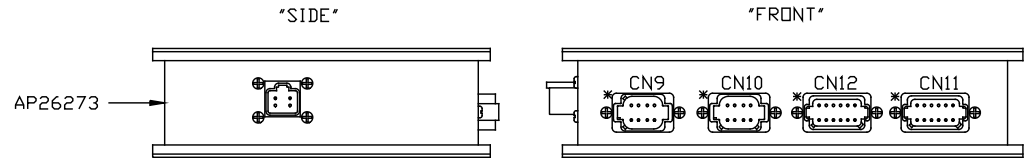

SILVER LEAF INTERFACE

- PIN
1 YELLOW CAN HI
2 GREEN CAN LOW
3 CAN SHIELD
4 N/C
5 N/C
6 N/C
7 N/C
8 N/C



120 OHM
TERMINATION
RESISTOR
PART OF AP25336

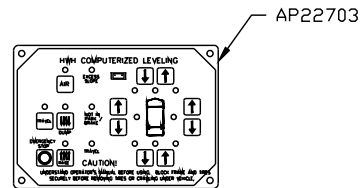
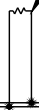

5 1

- PIN
1 YELLOW CAN HI
2 GREEN CAN LOW
3 CAN SHIELD
4 WHT(W6230) GROUND
5 BLK(W6800) SW. BATTERY

AP25336



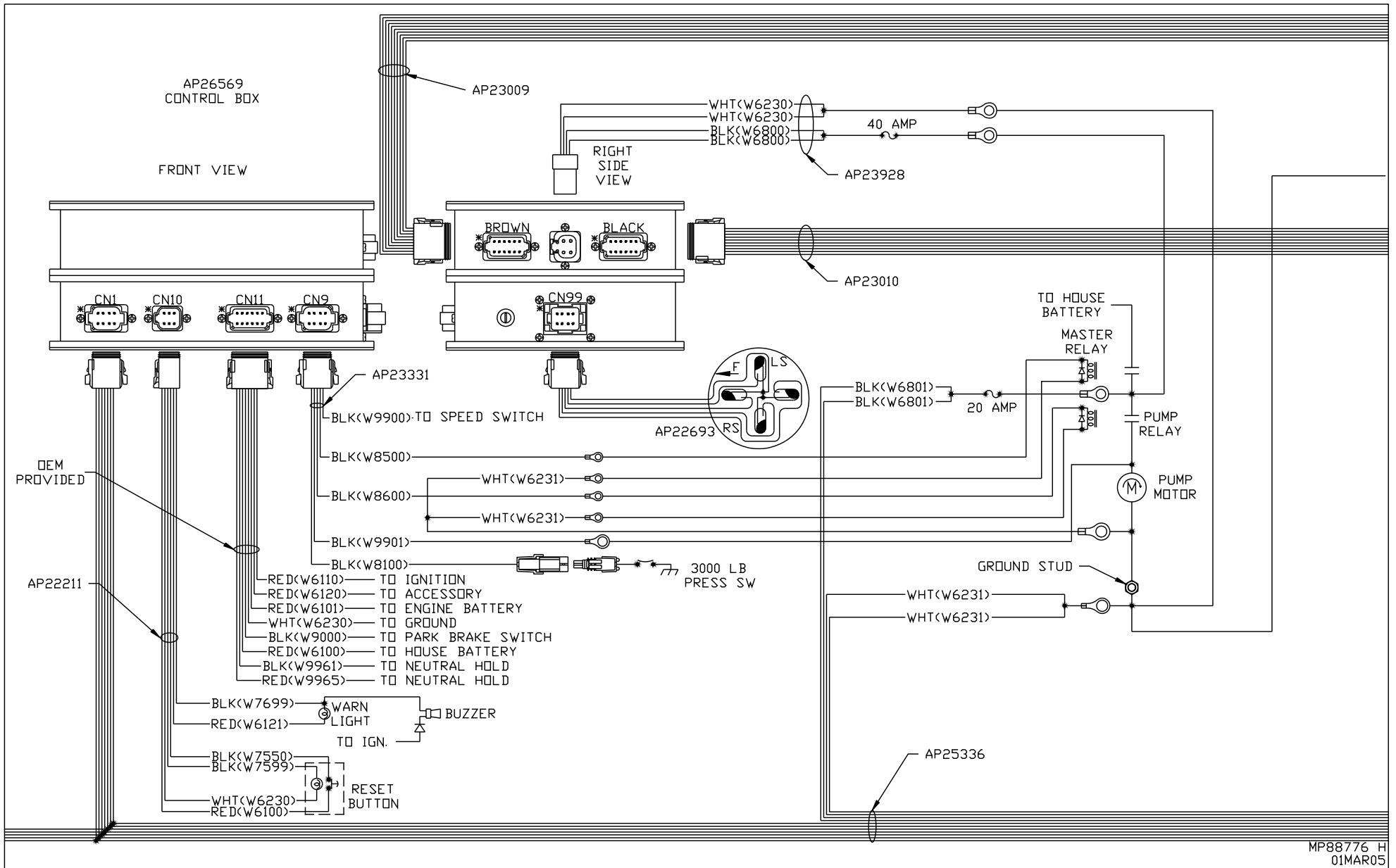

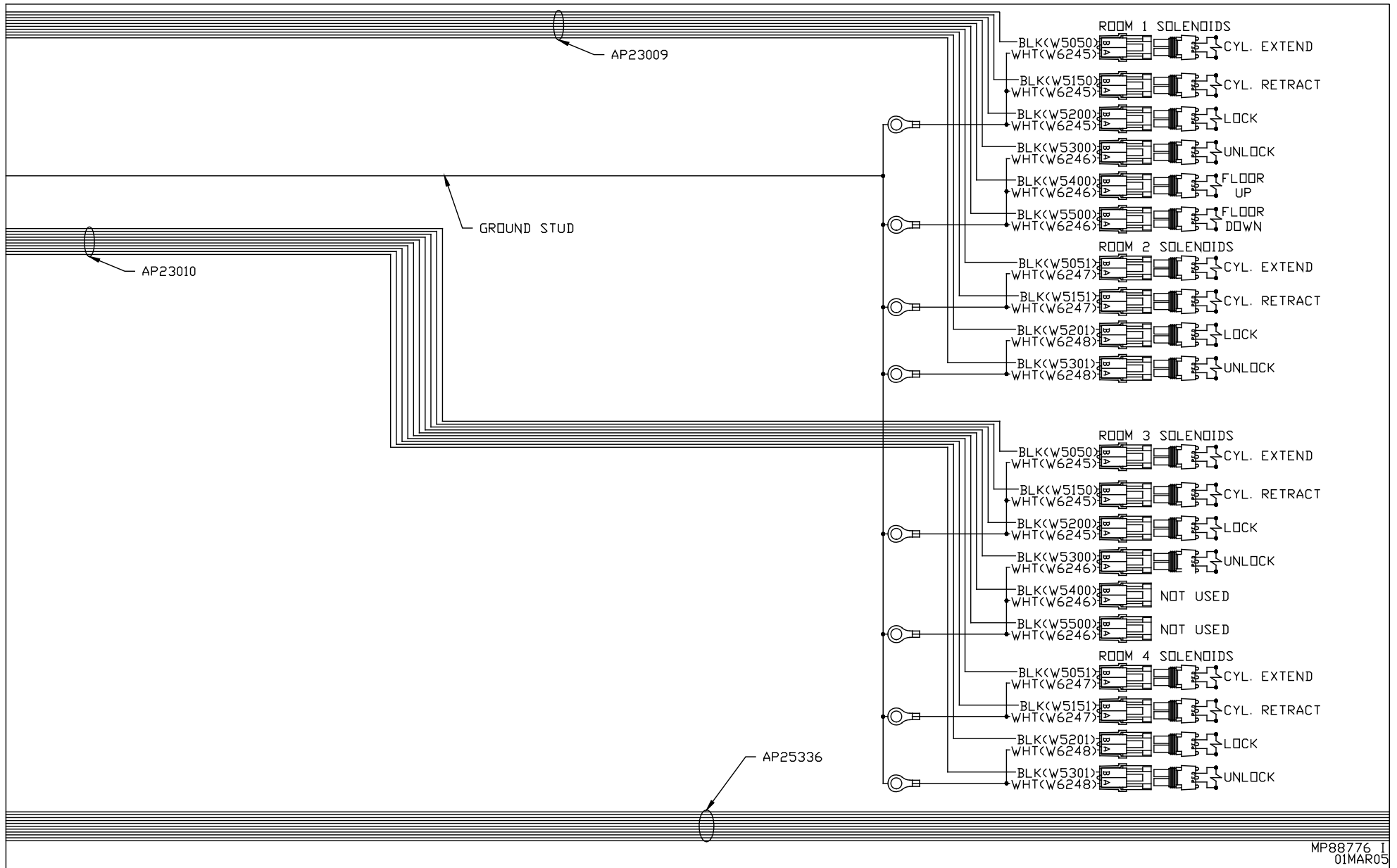

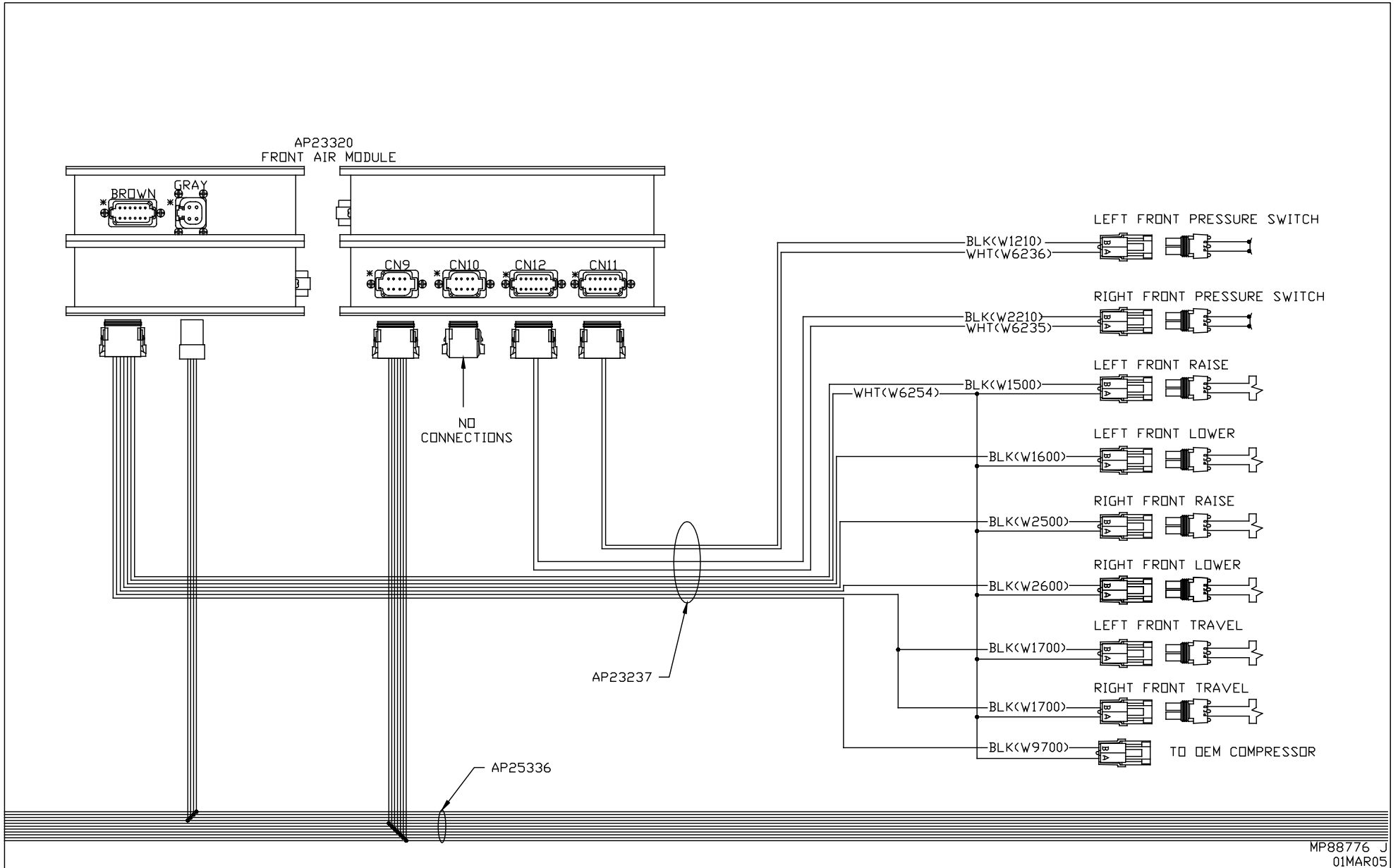

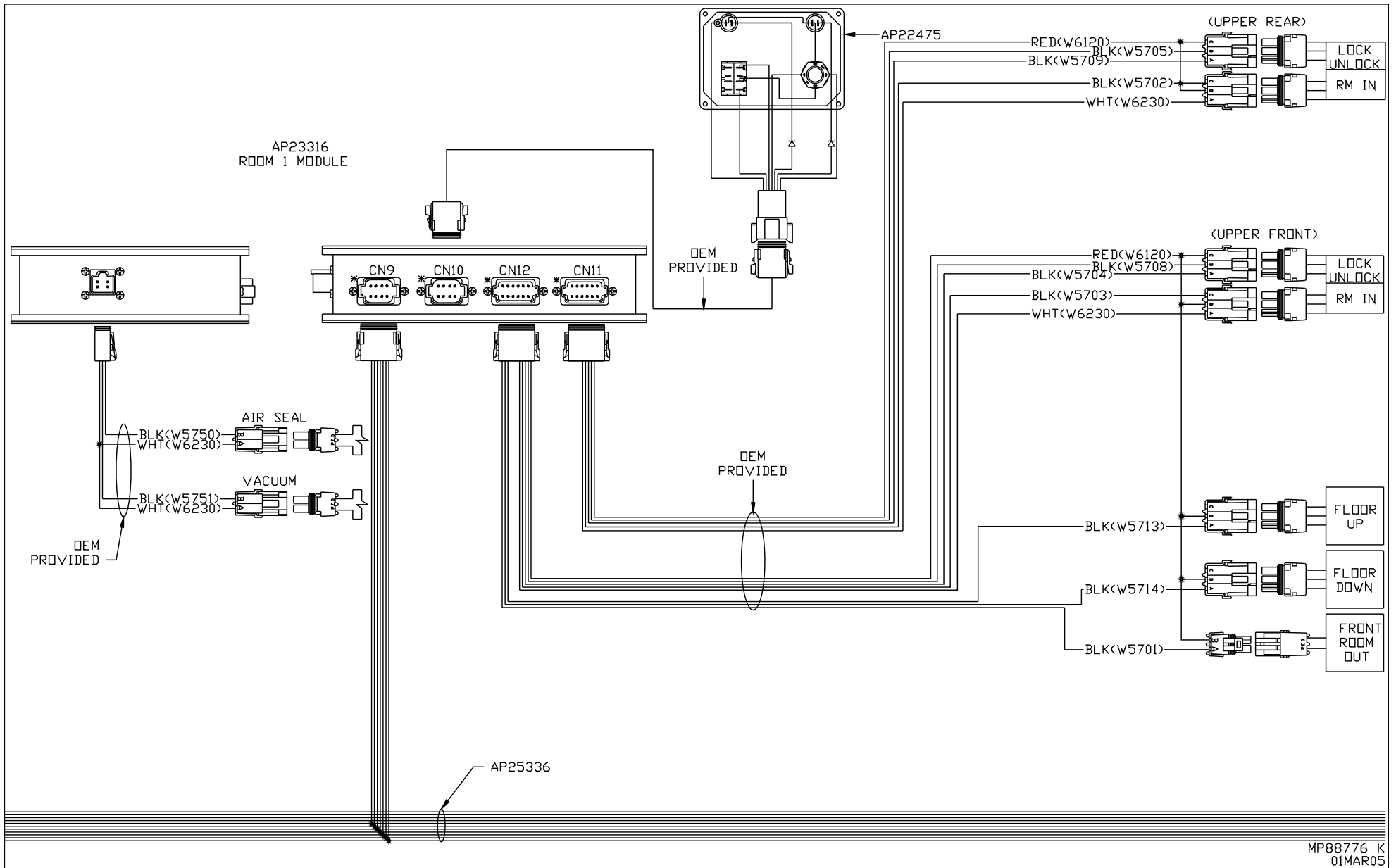

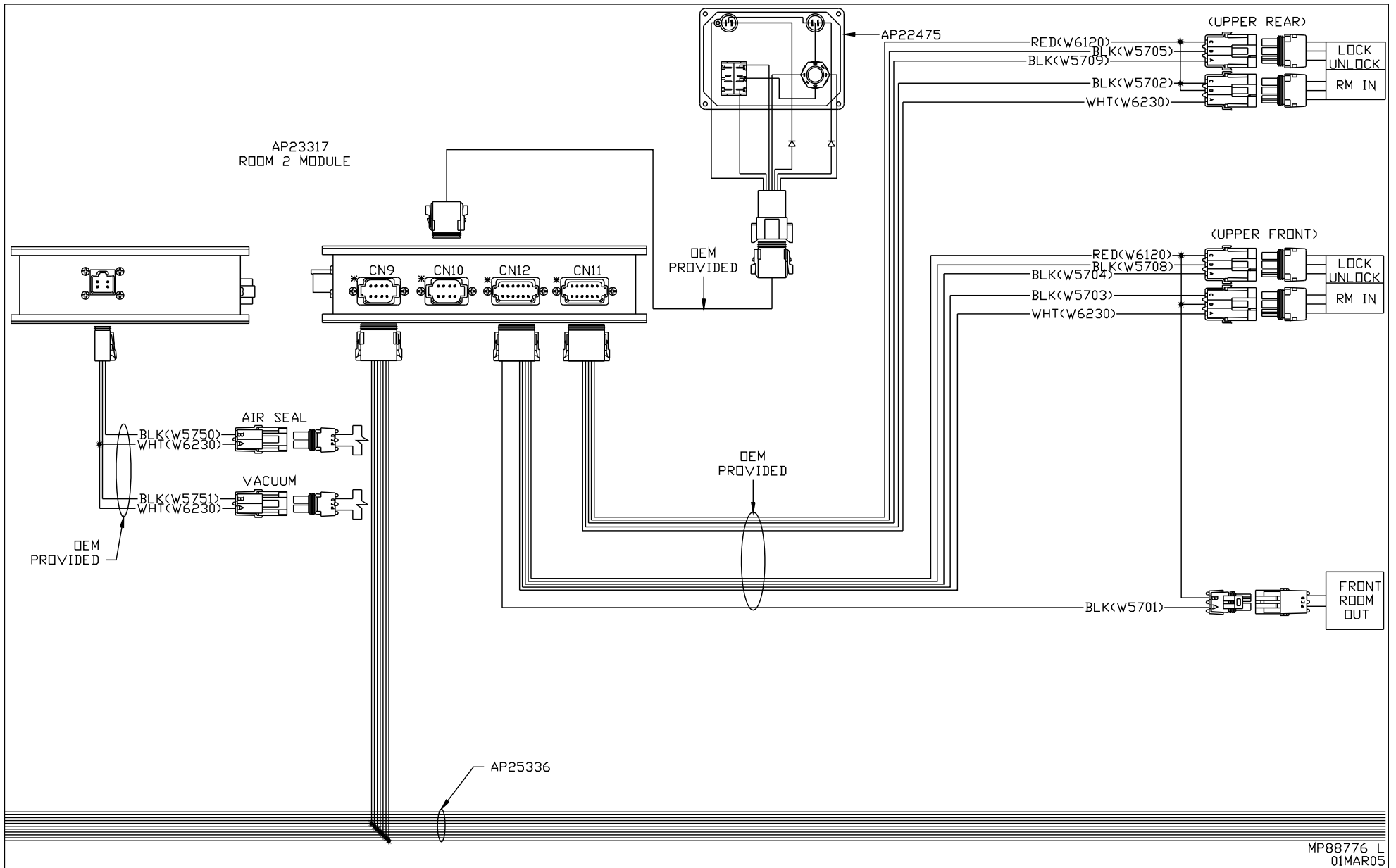

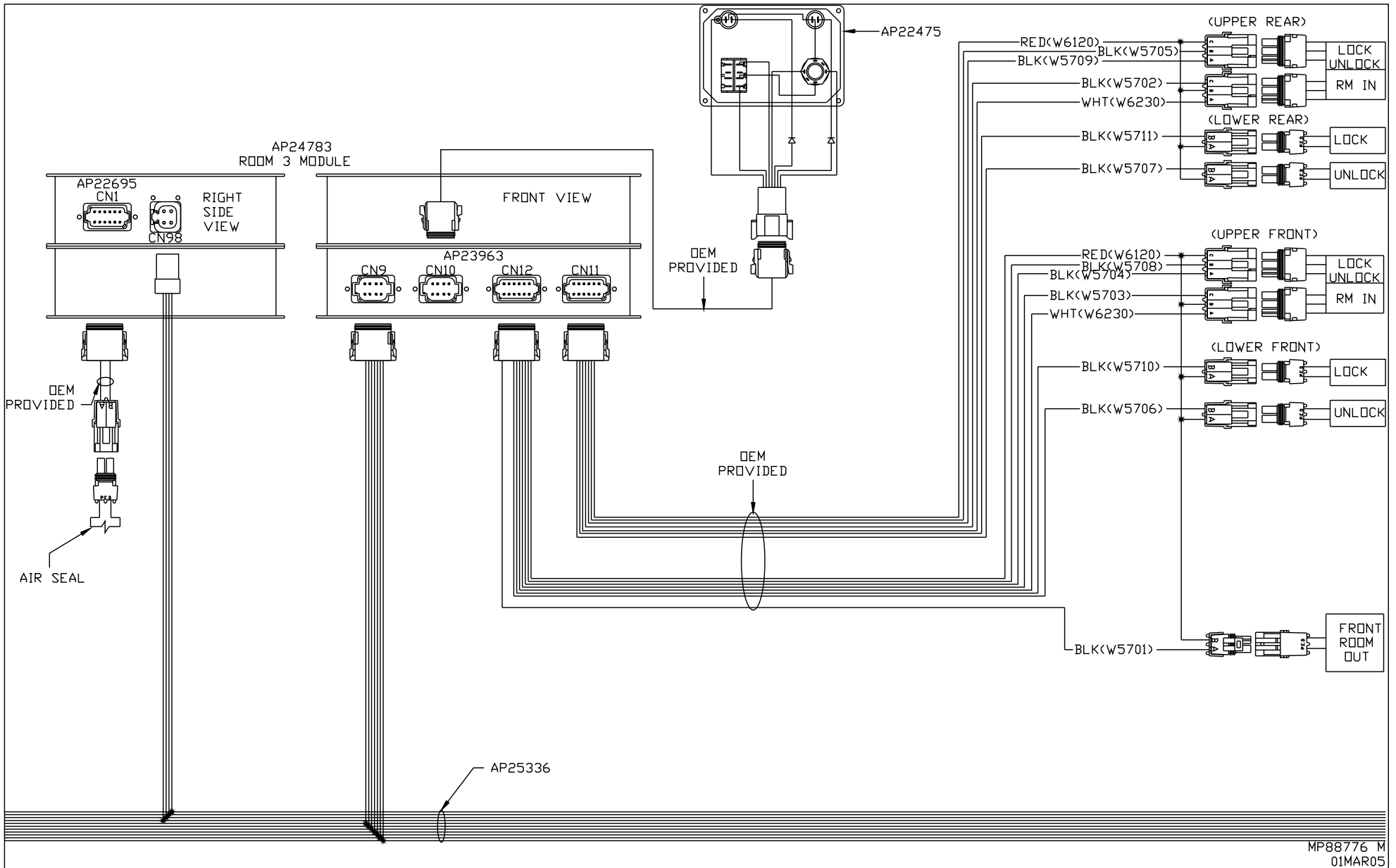

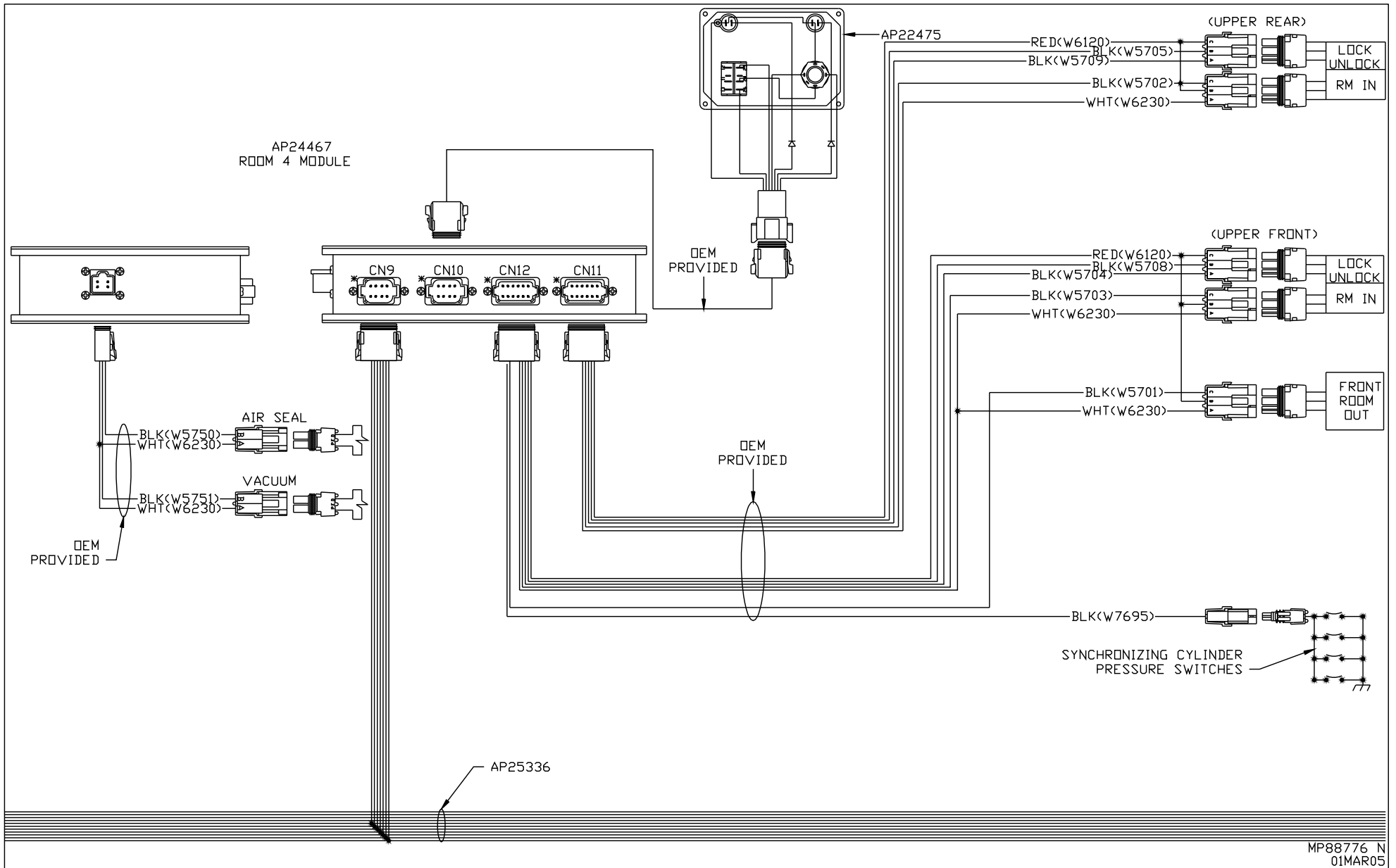

AP23321
REAR AIR MODULE

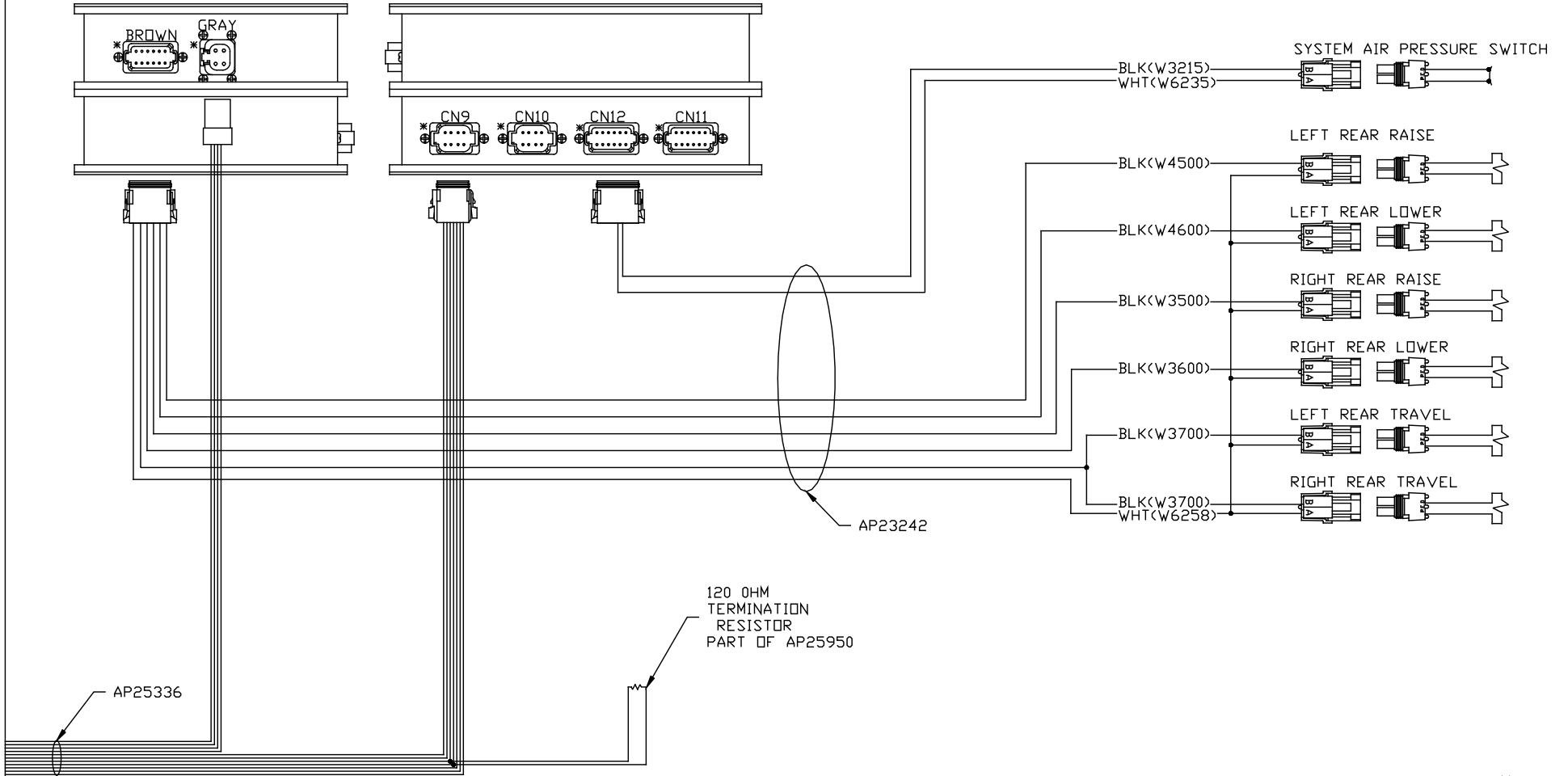

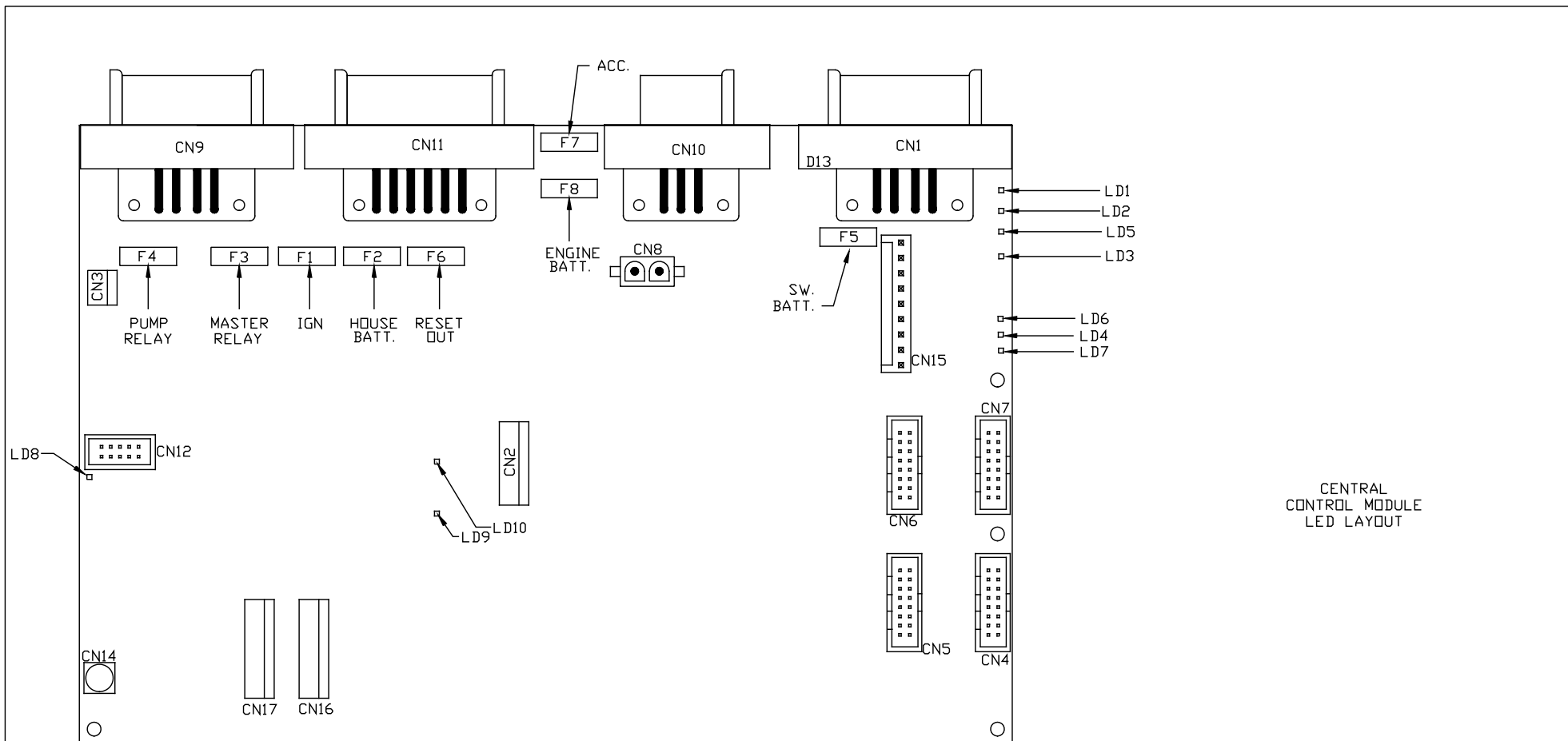

CENTRAL
CONTROL MODULE
LED LAYOUT

LED #	CONNECTOR	COLOR	DESCRIPTION
LED 1	CN 9 PIN 1	RED	MASTER RELAY
LED 2	CN 9 PIN 4	RED	PUMP RELAY
LED 3	CN 1 PIN 3	RED	SW 12V
LED 4	CN 11 PIN 12	RED	ENGINE BATT
LED 5	CN 9 PIN 5	RED	SPEED SWITCH
LED 6	NOT USED	NOT USED	NOT USED
LED 7	CN 1 PIN 7 & 8	RED	LINK LIGHT
LED 8	CN 11 PIN 8 & 9	RED	NEUTRAL HOLD
LED 9	NOT USED	NOT USED	NOT USED
LED 10	CN9 PIN 2	RED	3000 LBS. PSW

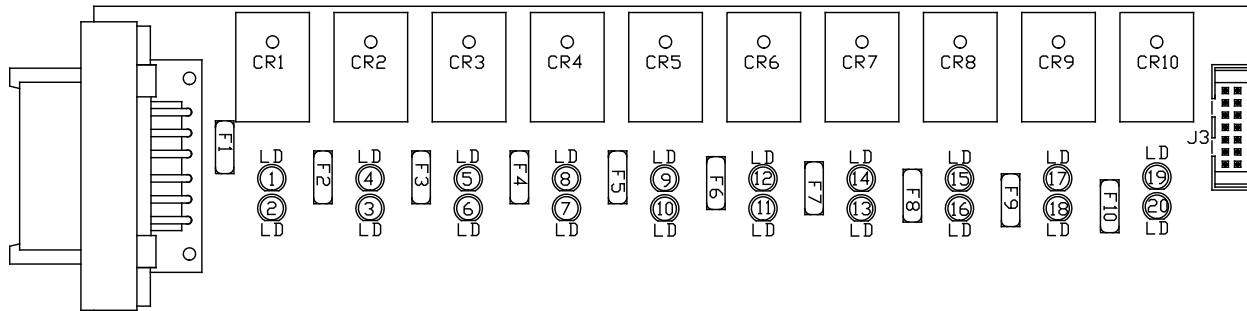

LED #	COLOR	INPUT J3	FUSE #	OUTPUT	RELAY #	DESCRIPTION
LED1	YELLOW	PIN 13	---	---	CR1	EXTEND CYL. RM 1 <COIL>
LED2	RED	---	FUSE 1	PIN 1	CR1	EXTEND CYL. RM 1 <CONTACT>
LED3	RED	---	FUSE 2	PIN 2	CR2	RETRACT CYL. RM 1 <CONTACT>
LED4	YELLOW	PIN 12	---	---	CR2	RETRACT CYL. RM 1 <COIL>
LED5	YELLOW	PIN 11	---	---	CR3	LOCK RM 1 <COIL>
LED6	RED	---	FUSE 3	PIN 3	CR3	LOCK RM 1 <CONTACT>
LED7	RED	---	FUSE 4	PIN 4	CR4	UNLOCK RM 1 <CONTACT>
LED8	YELLOW	PIN 10	---	---	CR4	UNLOCK RM 1 <COIL>
LED9	YELLOW	PIN 9	---	---	CR5	RM 1 FLOOR UP <COIL>
LED10	RED	---	FUSE 5	PIN 5	CR5	RM 1 FLOOR UP <CONTACT>
LED11	RED	---	FUSE 6	PIN 6	CR6	RM 1 FLOOR DOWN <CONTACT>
LED12	YELLOW	PIN 8	---	---	CR6	RM 1 FLOOR DOWN <COIL>
LED13	RED	---	FUSE 7	PIN 10	CR7	EXTEND CYL. RM 2 <CONTACT>
LED14	YELLOW	PIN 7	---	---	CR7	EXTEND CYL. RM 2 <COIL>
LED15	YELLOW	PIN 6	---	---	CR8	RETRACT CYL. RM 2 <COIL>
LED16	RED	---	FUSE8	PIN 9	CR8	RETRACT CYL. RM 2 <CONTACT>
LED17	YELLOW	PIN 5	---	---	CR9	LOCK RM 2 <COIL>
LED18	RED	---	FUSE 9	PIN 7	CR9	LOCK RM 2 <CONTACT>
LED19	YELLOW	PIN 4	---	---	CR10	UNLOCK RM 2 <COIL>
LED20	RED	---	FUSE 10	PIN 8	CR10	UNLOCK RM 2 <CONTACT>

ROOM 1 AND ROOM 2
HYDRAULIC OUTPUT
LED LAYOUT

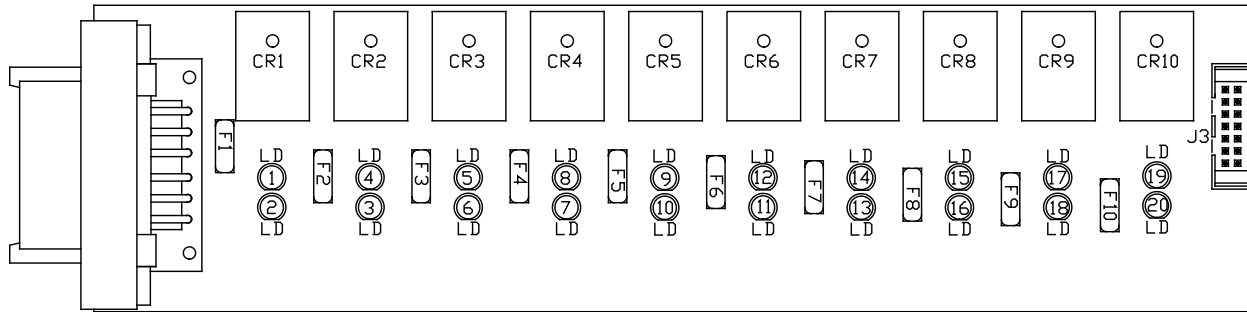

LED #	COLOR	INPUT J3	FUSE #	OUTPUT	RELAY #	DESCRIPTION
LED1	YELLOW	PIN 13	---	---	CR1	EXTEND CYL. RM 3 (COIL)
LED2	RED	---	FUSE 1	PIN 1	CR1	EXTEND CYL. RM 3 (CONTACT)
LED3	RED	---	FUSE 2	PIN 2	CR2	RETRACT CYL. RM 3 (CONTACT)
LED4	YELLOW	PIN 12	---	---	CR2	RETRACT CYL. RM 3 (COIL)
LED5	YELLOW	PIN 11	---	---	CR3	LOCK RM 3 (COIL)
LED6	RED	---	FUSE 3	PIN 3	CR3	LOCK RM 3 (CONTACT)
LED7	RED	---	FUSE 4	PIN 4	CR4	UNLOCK RM 3 (CONTACT)
LED8	YELLOW	PIN 10	---	---	CR4	UNLOCK RM 3 (COIL)
LED9	YELLOW	PIN 9	---	---	CR5	RM 3 FLOOR UP (COIL)
LED10	RED	---	FUSE 5	PIN 5	CR5	RM 3 FLOOR UP (CONTACT)
LED11	RED	---	FUSE 6	PIN 6	CR6	RM 3 FLOOR DOWN (CONTACT)
LED12	YELLOW	PIN 8	---	---	CR6	RM 3 FLOOR DOWN (COIL)
LED13	RED	---	FUSE 7	PIN 10	CR7	EXTEND CYL. RM 4 (CONTACT)
LED14	YELLOW	PIN 7	---	---	CR7	EXTEND CYL. RM 4 (COIL)
LED15	YELLOW	PIN 6	---	---	CR8	RETRACT CYL. RM 4 (COIL)
LED16	RED	---	FUSE8	PIN 9	CR8	RETRACT CYL. RM 4 (CONTACT)
LED17	YELLOW	PIN 5	---	---	CR9	LOCK RM 4 (COIL)
LED18	RED	---	FUSE 9	PIN 7	CR9	LOCK RM 4 (CONTACT)
LED19	YELLOW	PIN 4	---	---	CR10	UNLOCK RM 4 (COIL)
LED20	RED	---	FUSE 10	PIN 8	CR10	UNLOCK RM 4 (CONTACT)

ROOM 3 AND ROOM 4
HYDRAULIC OUTPUT
LED LAYOUT

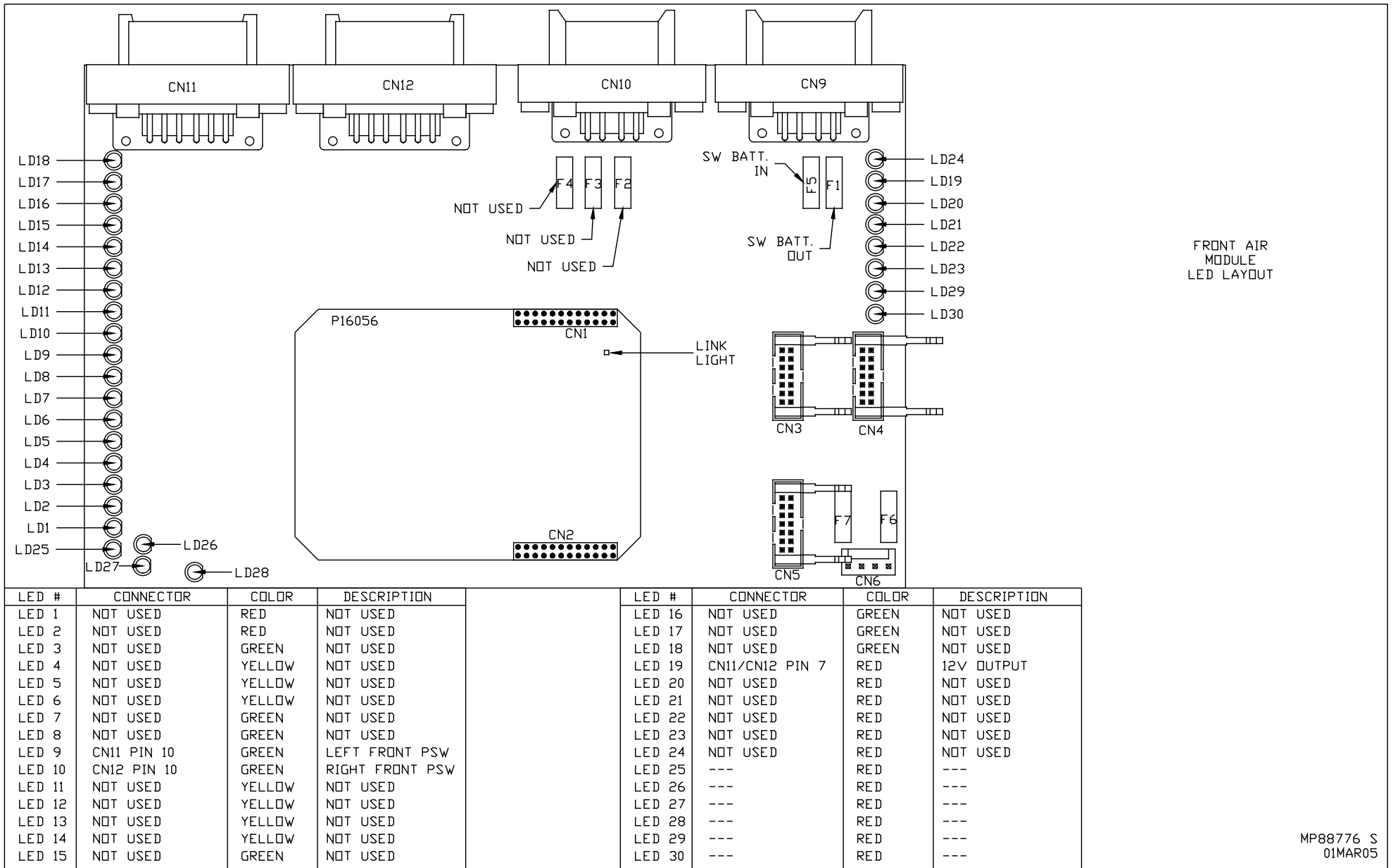

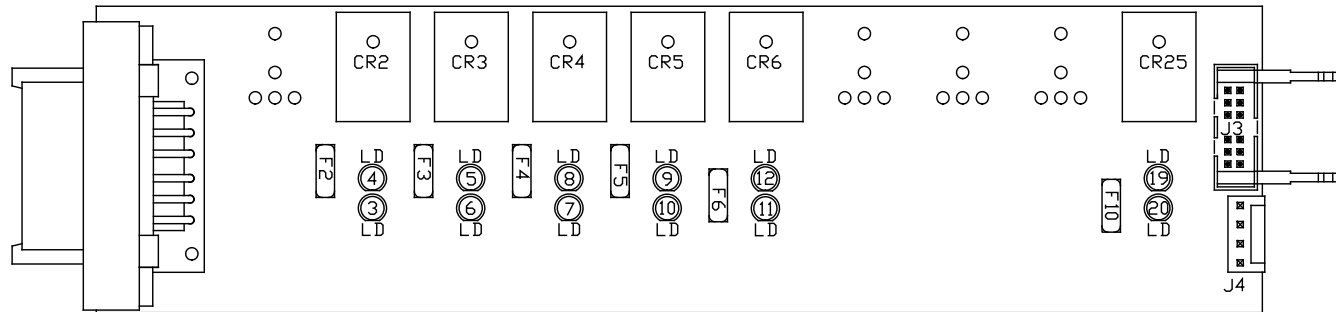

FRONT AIR OUTPUTS
LED LAYOUT

LED #	COLOR	INPUT J3	FUSE #	OUTPUT	RELAY #	DESCRIPTION
LED1	---	---	---	---	---	---
LED2	---	---	---	---	---	---
LED3	RED	---	FUSE 2	PIN 2	CR2	LEFT RAISE (CONTACT)
LED4	YELLOW	PIN 12	---	---	CR2	LEFT RAISE (COIL)
LED5	YELLOW	PIN 11	---	---	CR3	LEFT LOWER (COIL)
LED6	RED	---	FUSE 3	PIN 3	CR3	LEFT LOWER (CONTACT)
LED7	RED	---	FUSE 4	PIN 4	CR4	RIGHT RAISE (CONTACT)
LED8	YELLOW	PIN 10	---	---	CR4	RIGHT RAISE (COIL)
LED9	YELLOW	PIN 9	---	---	CR5	RIGHT LOWER (COIL)
LED10	RED	---	FUSE 5	PIN 5	CR5	RIGHT LOWER (CONTACT)
LED11	RED	---	FUSE 6	PIN 6	CR6	COMPRESSOR (CONTACT)
LED12	YELLOW	PIN 8	---	---	CR6	COMPRESSOR (COIL)
LED13	---	---	---	---	---	---
LED14	---	---	---	---	---	---
LED15	---	---	---	---	---	---
LED16	---	---	---	---	---	---
LED17	---	---	---	---	---	---
LED18	---	---	---	---	---	---
LED19	YELLOW	PIN 4	---	---	CR25	TRAVEL (COIL)
LED20	RED	---	FUSE 10	PIN 8	CR25	TRAVEL (CONTACT)

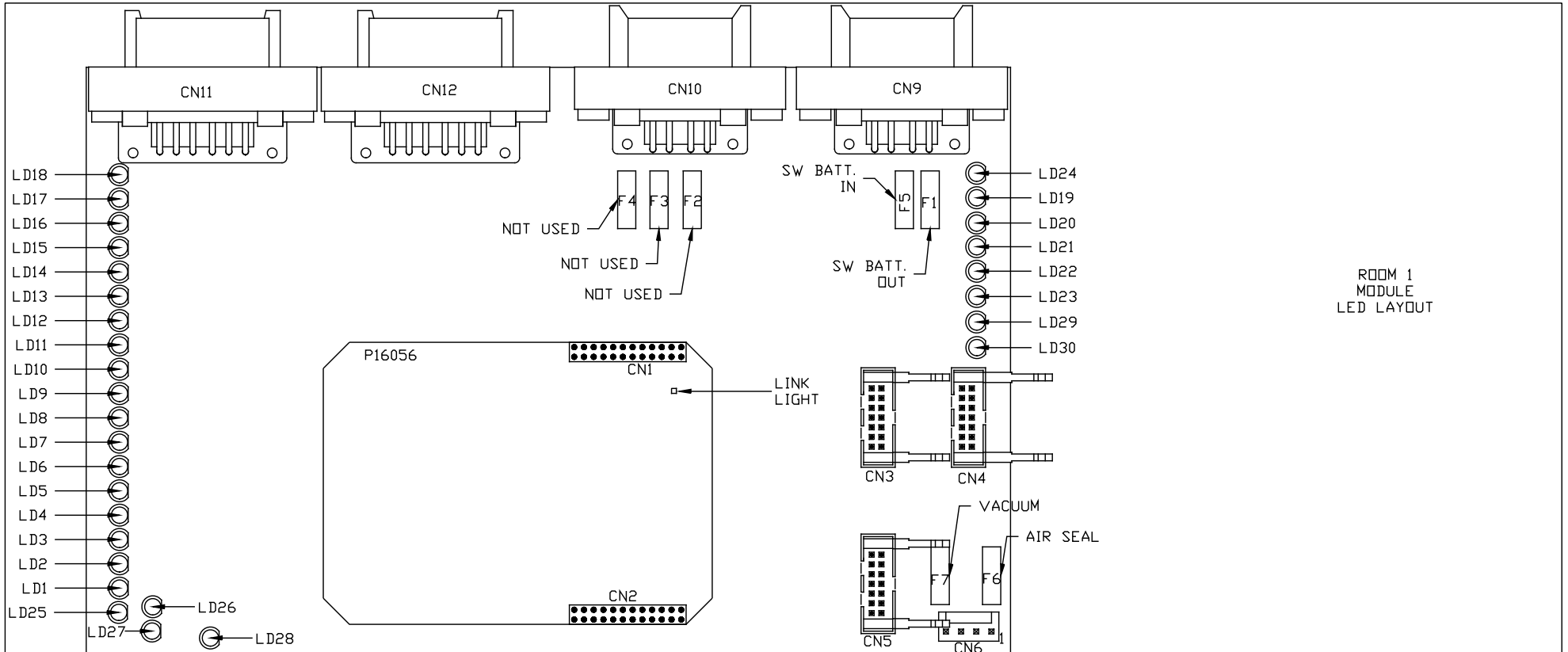

ROOM 1
MODULE
LED LAYOUT

LED #	CONNECTOR	COLOR	DESCRIPTION	LED #	CONNECTOR	COLOR	DESCRIPTION
LED 1	CN10 PIN 4	RED	EXTEND	LED 16	NOT USED	GREEN	NOT USED
LED 2	CN10 PIN 5	RED	RETRACT	LED 17	CN11 PIN 9	GREEN	REAR LOCK
LED 3	CN12 PIN 8	GREEN	FLOOR UP	LED 18	CN12 PIN 9	GREEN	FRONT LOCK
LED 4	CN12 PIN 5	YELLOW	FLOOR DOWN	LED 19	CN11/CN12 PIN 7	RED	12V OUTPUT
LED 5	NOT USED	YELLOW	NOT USED	LED 20	NOT USED	RED	NOT USED
LED 6	CN12 PIN 2	YELLOW	ROOM OUT	LED 21	NOT USED	RED	NOT USED
LED 7	NOT USED	GREEN	NOT USED	LED 22	NOT USED	RED	NOT USED
LED 8	NOT USED	GREEN	NOT USED	LED 23	NOT USED	RED	NOT USED
LED 9	CN11 PIN 10	GREEN	REAR ROOM IN	LED 24	NOT USED	RED	NOT USED
LED 10	CN12 PIN 10	GREEN	FRONT ROOM IN	LED 25	---	RED	---
LED 11	NOT USED	YELLOW	NOT USED	LED 26	---	RED	---
LED 12	NOT USED	YELLOW	NOT USED	LED 27	---	RED	---
LED 13	CN11 PIN 12	YELLOW	REAR UNLOCK	LED 28	---	RED	---
LED 14	CN12 PIN 12	YELLOW	FRONT UNLOCK	LED 29	CN6 PIN 1	RED	AIR SEAL OUTPUT
LED 15	NOT USED	GREEN	NOT USED	LED 30	CN6 PIN 3	RED	VACUUM OUTPUT

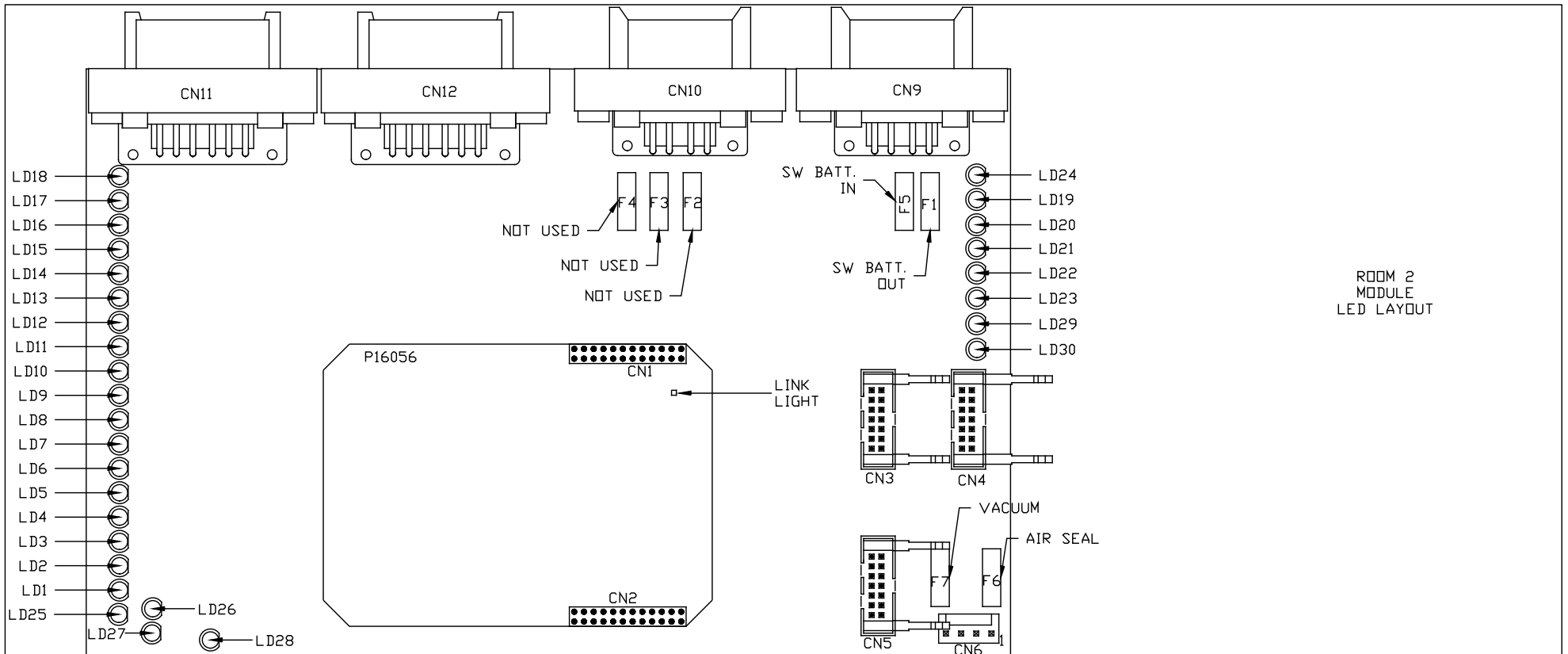

ROOM 2
MODULE
LED LAYOUT

LED #	CONNECTOR	COLOR	DESCRIPTION	LED #	CONNECTOR	COLOR	DESCRIPTION
LED 1	CN10 PIN 4	RED	EXTEND	LED 16	NOT USED	GREEN	NOT USED
LED 2	CN10 PIN 5	RED	RETRACT	LED 17	CN11 PIN 9	GREEN	REAR LOCK
LED 3	NOT USED	GREEN	NOT USED	LED 18	CN12 PIN 9	GREEN	FRONT LOCK
LED 4	NOT USED	YELLOW	NOT USED	LED 19	CN11/CN12 PIN 7	RED	12V OUTPUT
LED 5	NOT USED	YELLOW	NOT USED	LED 20	NOT USED	RED	NOT USED
LED 6	CN12 PIN 2	YELLOW	ROOM OUT	LED 21	NOT USED	RED	NOT USED
LED 7	NOT USED	GREEN	NOT USED	LED 22	NOT USED	RED	NOT USED
LED 8	NOT USED	GREEN	NOT USED	LED 23	NOT USED	RED	NOT USED
LED 9	CN11 PIN 10	GREEN	REAR ROOM IN	LED 24	NOT USED	RED	NOT USED
LED 10	CN12 PIN 10	GREEN	FRONT ROOM IN	LED 25	---	RED	---
LED 11	NOT USED	YELLOW	NOT USED	LED 26	---	RED	---
LED 12	NOT USED	YELLOW	NOT USED	LED 27	---	RED	---
LED 13	CN11 PIN 12	YELLOW	REAR UNLOCK	LED 28	---	RED	---
LED 14	CN12 PIN 12	YELLOW	FRONT UNLOCK	LED 29	CN6 PIN 1	RED	AIR SEAL OUTPUT
LED 15	NOT USED	GREEN	NOT USED	LED 30	CN6 PIN 3	RED	VACUUM OUTPUT

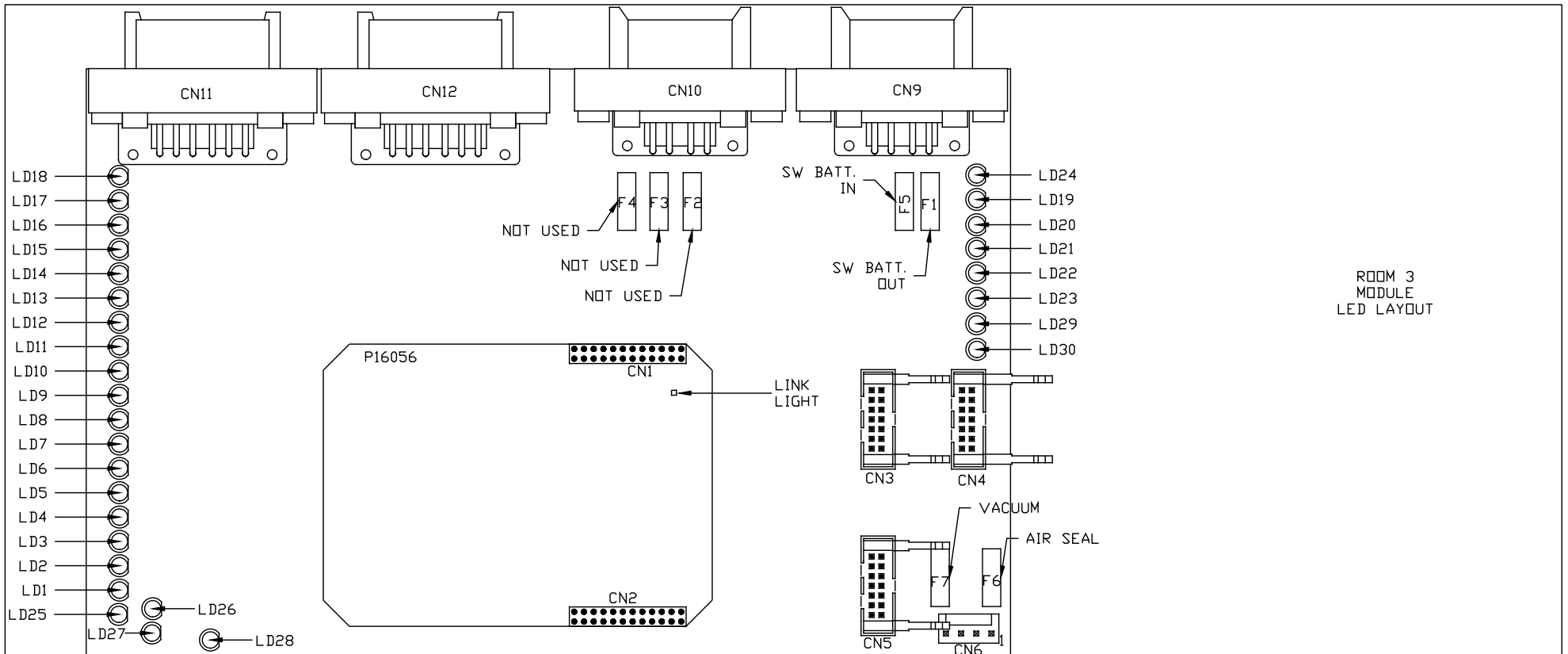

ROOM 3
MODULE
LED LAYOUT

LED #	CONNECTOR	COLOR	DESCRIPTION	LED #	CONNECTOR	COLOR	DESCRIPTION
LED 1	CN10 PIN 4	RED	EXTEND	LED 16	NOT USED	GREEN	NOT USED
LED 2	CN10 PIN 5	RED	RETRACT	LED 17	CN11 PIN 9	GREEN	REAR LOCK
LED 3	NOT USED	GREEN	NOT USED	LED 18	CN12 PIN 9	GREEN	FRONT LOCK
LED 4	NOT USED	YELLOW	NOT USED	LED 19	CN11/CN12 PIN 7	RED	12V OUTPUT
LED 5	NOT USED	YELLOW	NOT USED	LED 20	NOT USED	RED	NOT USED
LED 6	CN12 PIN 2	YELLOW	ROOM OUT	LED 21	NOT USED	RED	NOT USED
LED 7	NOT USED	GREEN	NOT USED	LED 22	NOT USED	RED	NOT USED
LED 8	NOT USED	GREEN	NOT USED	LED 23	NOT USED	RED	NOT USED
LED 9	CN11 PIN 10	GREEN	REAR ROOM IN	LED 24	NOT USED	RED	NOT USED
LED 10	CN12 PIN 10	GREEN	FRONT ROOM IN	LED 25	---	RED	---
LED 11	NOT USED	YELLOW	NOT USED	LED 26	---	RED	---
LED 12	NOT USED	YELLOW	NOT USED	LED 27	---	RED	---
LED 13	CN11 PIN 12	YELLOW	REAR UNLOCK	LED 28	---	RED	---
LED 14	CN12 PIN 12	YELLOW	FRONT UNLOCK	LED 29	CN6 PIN 1	RED	AIR SEAL OUTPUT
LED 15	NOT USED	GREEN	NOT USED	LED 30	CN6 PIN 3	RED	VACUUM OUTPUT

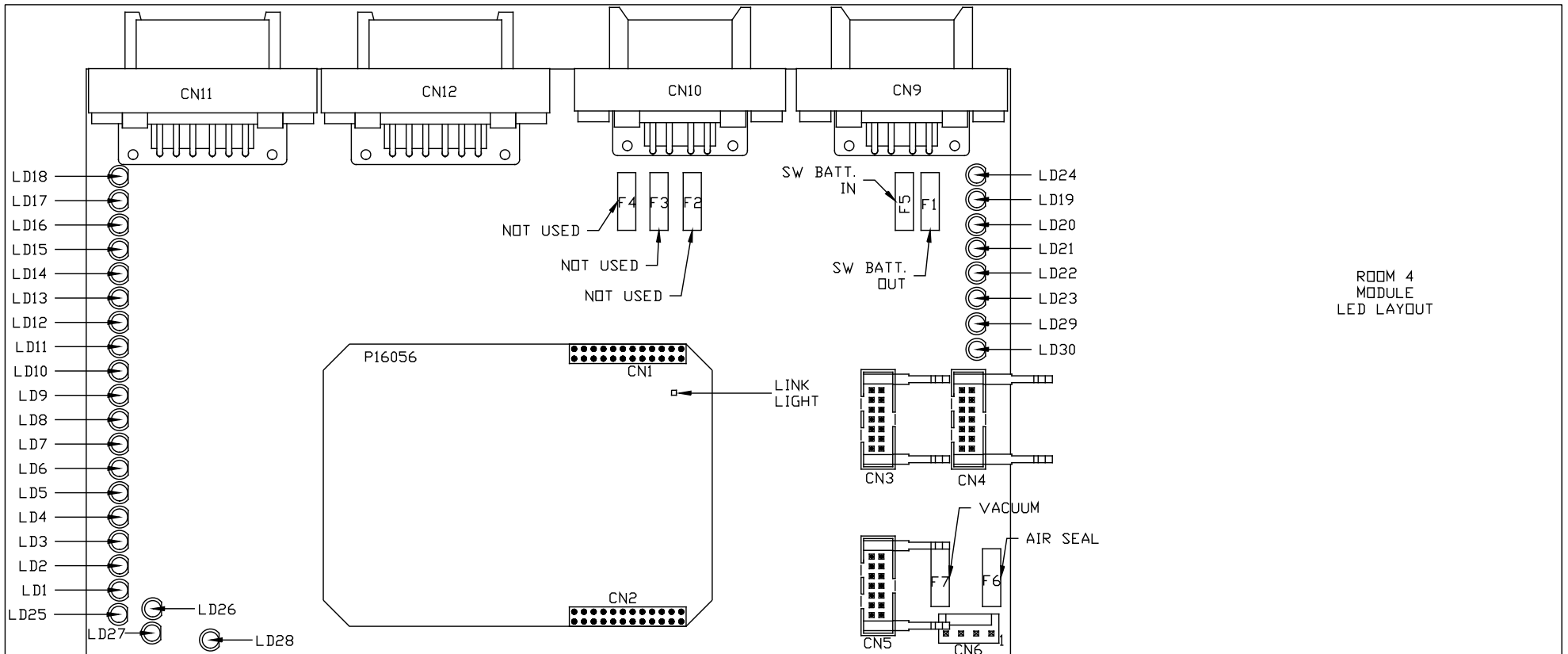

LED #	CONNECTOR	COLOR	DESCRIPTION	LED #	CONNECTOR	COLOR	DESCRIPTION
LED 1	CN10 PIN 4	RED	EXTEND	LED 16	NOT USED	GREEN	NOT USED
LED 2	CN10 PIN 5	RED	RETRACT	LED 17	CN11 PIN 9	GREEN	REAR LOCK
LED 3	NOT USED	GREEN	NOT USED	LED 18	CN12 PIN 9	GREEN	FRONT LOCK
LED 4	NOT USED	YELLOW	NOT USED	LED 19	CN11/CN12 PIN 7	RED	12V OUTPUT
LED 5	NOT USED	YELLOW	NOT USED	LED 20	NOT USED	RED	NOT USED
LED 6	CN12 PIN 2	YELLOW	ROOM OUT	LED 21	NOT USED	RED	NOT USED
LED 7	NOT USED	GREEN	NOT USED	LED 22	NOT USED	RED	NOT USED
LED 8	NOT USED	GREEN	NOT USED	LED 23	NOT USED	RED	NOT USED
LED 9	CN11 PIN 10	GREEN	REAR ROOM IN	LED 24	NOT USED	RED	NOT USED
LED 10	CN12 PIN 10	GREEN	FRONT ROOM IN	LED 25	---	RED	---
LED 11	NOT USED	YELLOW	NOT USED	LED 26	---	RED	---
LED 12	NOT USED	YELLOW	NOT USED	LED 27	---	RED	---
LED 13	CN11 PIN 12	YELLOW	REAR UNLOCK	LED 28	CN12 PIN 11	RED	SYNCH CYL. PSW
LED 14	CN12 PIN 12	YELLOW	FRONT UNLOCK	LED 29	CN6 PIN 1	RED	AIR SEAL OUTPUT
LED 15	NOT USED	GREEN	NOT USED	LED 30	CN6 PIN 3	RED	VACUUM OUTPUT

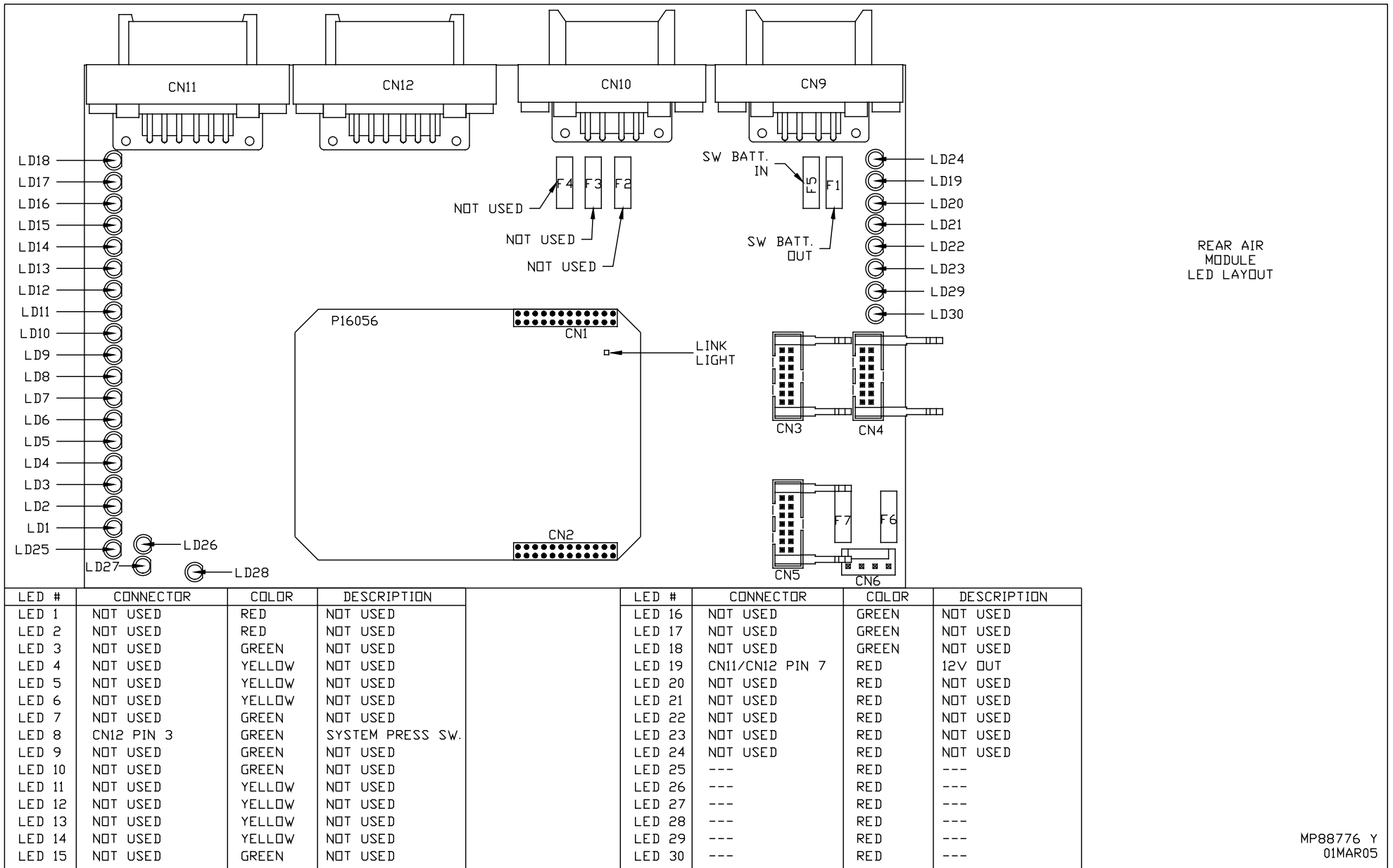

REAR AIR
MODULE
LED LAYOUT

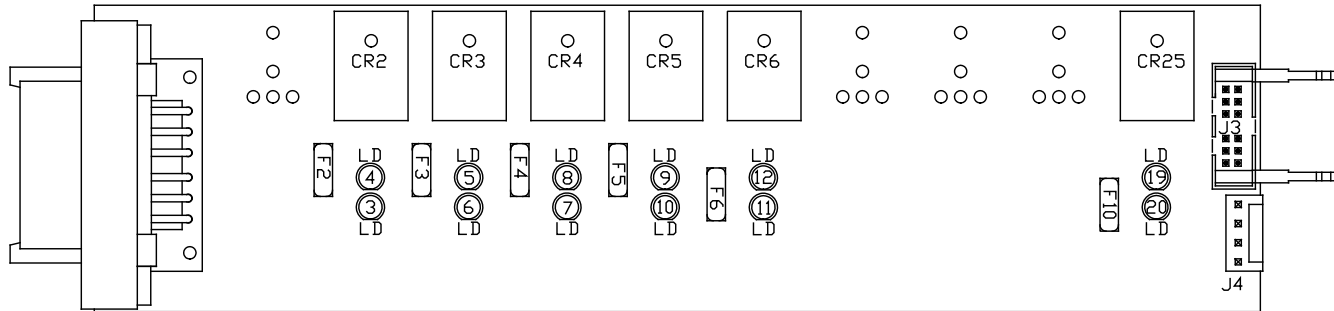

LED #	COLOR	INPUT J3	FUSE #	OUTPUT	RELAY #	DESCRIPTION
LED1	---	---	---	---	---	---
LED2	---	---	---	---	---	---
LED3	RED	---	FUSE 2	PIN 2	CR2	LEFT RAISE (CONTACT)
LED4	YELLOW	PIN 12	---	---	CR2	LEFT RAISE (COIL)
LED5	YELLOW	PIN 11	---	---	CR3	LEFT LOWER (COIL)
LED6	RED	---	FUSE 3	PIN 3	CR3	LEFT LOWER (CONTACT)
LED7	RED	---	FUSE 4	PIN 4	CR4	RIGHT RAISE (CONTACT)
LED8	YELLOW	PIN 10	---	---	CR4	RIGHT RAISE (COIL)
LED9	YELLOW	PIN 9	---	---	CR5	RIGHT LOWER (COIL)
LED10	RED	---	FUSE 5	PIN 5	CR5	RIGHT LOWER (CONTACT)
LED11	RED	---	FUSE 6	PIN 6	CR6	COMPRESSOR (CONTACT)
LED12	YELLOW	PIN 8	---	---	CR6	COMPRESSOR (COIL)
LED13	---	---	---	---	---	---
LED14	---	---	---	---	---	---
LED15	---	---	---	---	---	---
LED16	---	---	---	---	---	---
LED17	---	---	---	---	---	---
LED18	---	---	---	---	---	---
LED19	YELLOW	PIN 4	---	---	CR25	TRAVEL (COIL)
LED20	RED	---	FUSE 10	PIN 8	CR25	TRAVEL (CONTACT)

REAR AIR OUTPUTS
LED LAYOUT