

- P12-P1
1. BLUE
 2. BROWN
 3. GRAY
 4. PURPLE
 5. BLACK/WHITE
 6. BLACK
 7. WHITE/BLACK
 8. WHITE
 9. ORANGE/BLACK
 10. ORANGE
 11. GREEN
 12. GREEN/BLACK
 13. RED/BLACK
 14. KEYING PIN
 15. RED

- P13
1. N/C
 2. BLK(W8601) JACK INTERRUPT
 3. N/C
 4. N/C
 5. N/C
 6. N/C

- P2
1. BLK(W4000) LEFT REAR WARNING SW.
 2. BLK(W3000) RIGHT REAR WARNING SW.
 3. BLK(W2000) RIGHT FRONT WARNING SW.
 4. BLK(W1000) LEFT FRONT WARNING SW.
 5. WHT(W6235) GROUND
 6. KEY PIN
 7. N/C
 8. BLK(W7699) WARNING LIGHT/BUZZER CONTROL
 9. N/C

- P3
1. REAR SENSE (RED)
 2. RIGHT SIDE SENSE (GREEN)
 3. FRONT SENSE (BLACK)
 4. LEFT SIDE SENSE (YELLOW)
 5. GROUND (WHITE)

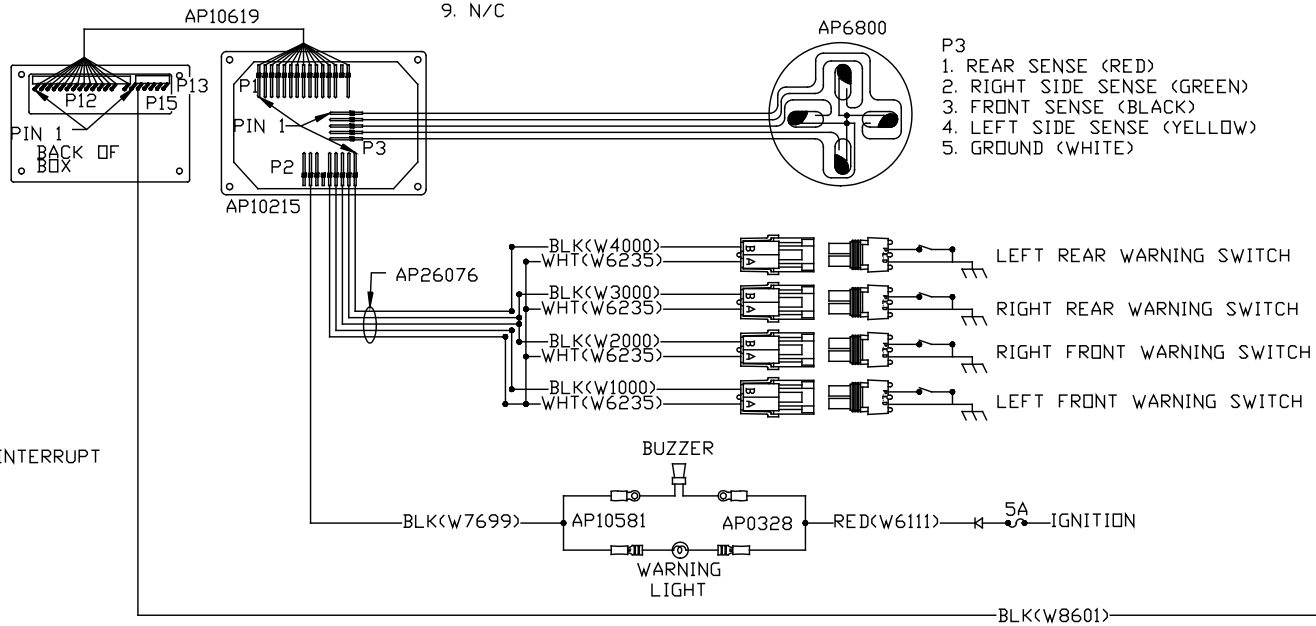

			HWH I-80 EXIT 267 SOUTH RT 1 MOSCOW, IOWA 52760		
			SCALE 1:3	DATE 12JUL02	DRAWN BY .
			SYSTEM SCHEMATIC ELEC		
NO.	DATE	REVISION			
THE INFORMATION DISCLOSED ON THIS DRAWING IS CONFIDENTIAL AND MUST NOT BE DISCLOSED OR USED IN ANY MANNER WHICH WILL BE DETRIMENTAL TO THE HWH CORPORATION			DRAWING NUMBER MP88930 A/C		

