

AP29291

GRAY 12 PIN

1. BLK(W1400) LF CONTROL
2. BLK(W3400) RR CONTROL
3. BLK(W9301) TRAVEL
4. WHT(W6230) GROUND
5. BLK(W8110) PSW DISABLE
6. BLK(W9300) DUMP
7. BLK(W9000) PARK BRAKE
8. N/C
9. BLK(W2400) RF CONTROL
10. BLK(W4400) LR CONTROL
11. BLK(W8600) PUMP RELAY CONTROL
12. BLK(W6121) ACCESSORY

BROWN 12 PIN

1. N/C
2. WHT(W6243) GROUND
3. WHT(W6242) GROUND
4. WHT(W6241) GROUND
5. WHT(W6240) GROUND
6. BLK(W8100) MANIFOLD PRESS SW.
7. BLK(W9000) PARK BRAKE
8. BLK(W4400) LEFT REAR SOLENOID
9. BLK(W2400) RIGHT FRONT SOLENOID
10. BLK(W1400) LEFT FRONT SOLENOID
11. BLK(W3400) RIGHT REAR SOLENOID
12. BLK(W8600) PUMP RELAY CONTROL

BLACK 12 PIN

1. N/C
2. N/C
3. N/C
4. N/C
5. N/C
6. WHT(W6230) GROUND
7. BLK(W9300) DUMP
8. BLK(W9301) TRAVEL
9. N/C
10. N/C
11. N/C
12. N/C

GRAY 8 PIN

1. BLK(W0400) REAR SENSE
2. BLK(W0300) RIGHT SIDE SENSE
3. BLK(W0200) FRONT SENSE
4. BLK(W0100) LEFT SIDE SENSE
5. N/C
6. N/C
7. N/C
8. BLK(W6122) ACCESSORY

GREEN 12 PIN

1. BLK(W5050) CYL EXT. ROOM 1
2. BLK(W5150) CYL RET. ROOM 1
3. BLK(W5051) CYL EXT. ROOM 2
4. BLK(W5151) CYL RET. ROOM 2
5. BLK(W5052) CYL EXT. ROOM 3
6. BLK(W5152) CYL RET. ROOM 3
7. BLK(W5053) CYL EXT. ROOM 4
8. BLK(W5153) CYL RET. ROOM 4
9. BLK(W6810) SW. BATTERY
10. BLK(W6810) SW. BATTERY
11. BLK(W6810) SW. BATTERY
12. BLK(W6810) SW. BATTERY

GRAY 4 PIN

1. RED(W6100) BATTERY
2. RED(W6100) BATTERY
3. WHT(W6230) GROUND
4. WHT(W6230) GROUND

NOTE: WIRE NUMBERS ON THIS SHEET ARE REFERENCED TO HARNESS PLUGS.

		HWH		I-80 EXIT 267 SOUTH RT 1 MOSCOW, IOWA 52760	
		SCALE 1:3	DATE 29AUG03	DRAWN BY	
▲	28APR06	WAS W5702		SYSTEM SCHEMATIC ELEC	
NO.	DATE	REVISION			
THE INFORMATION DISCLOSED ON THIS DRAWING IS CONFIDENTIAL AND MUST NOT BE DISCLOSED OR USED IN ANY MANNER WHICH WILL BE DETRIMENTAL TO THE HWH CORPORATION				DRAWING NUMBER MP89112 A/F	

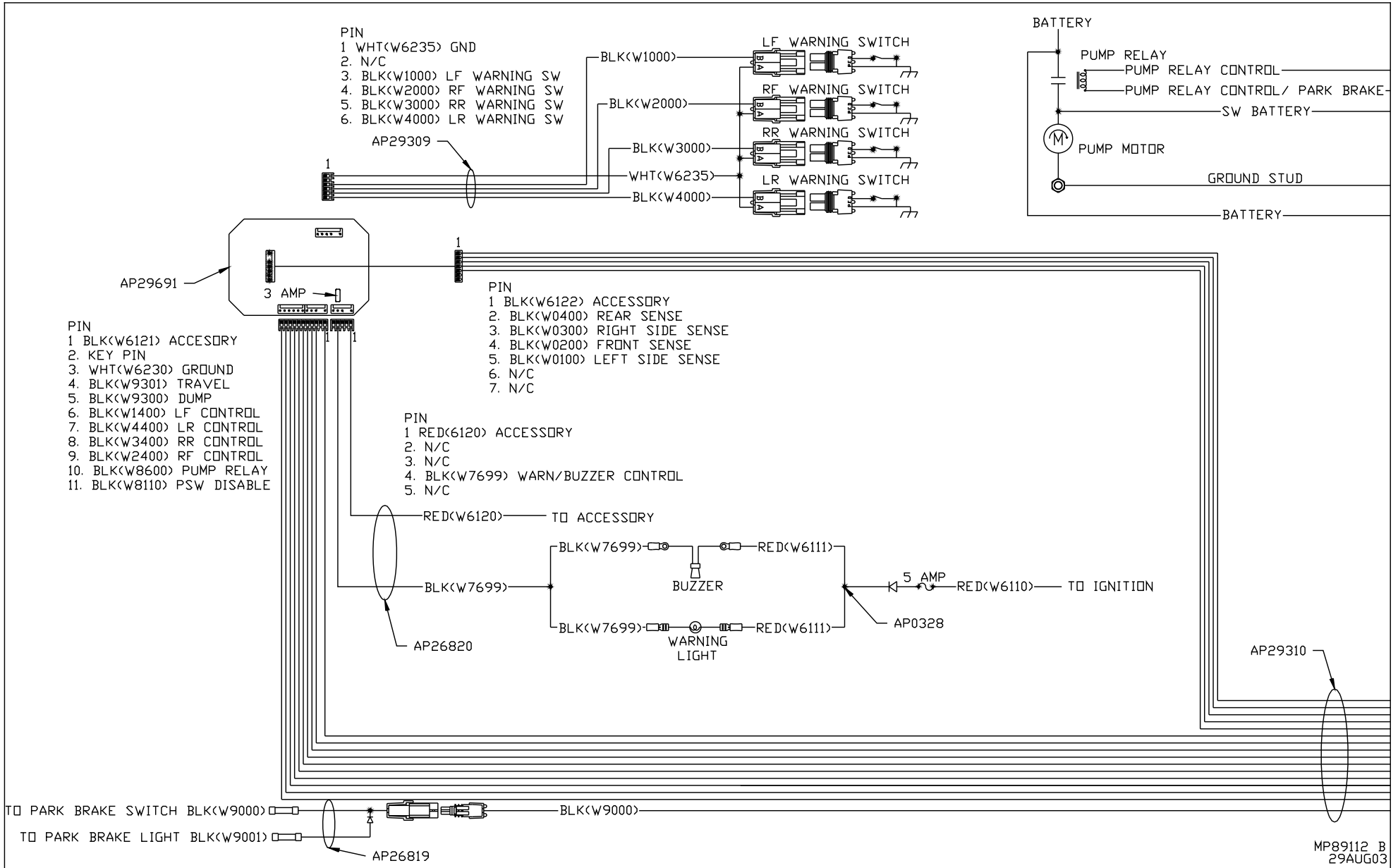

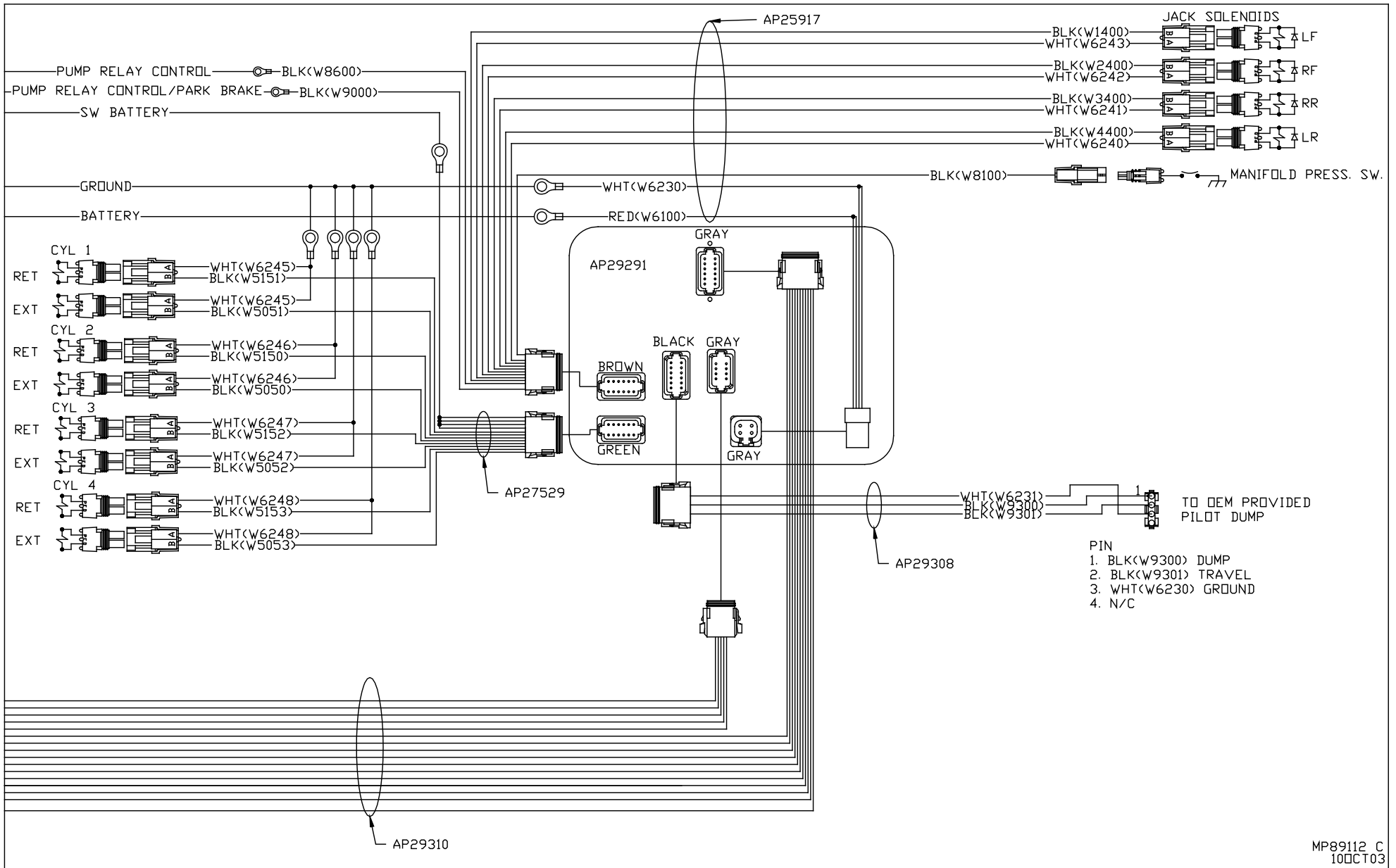

BLACK 12 PIN

1. N/C
2. BLK(W5000) EXTEND ROOM 1
3. BLK(W5100) RETRACT ROOM 1
4. BLK(W6811) SW. BATT ROOM 2
5. BLK(W5001) EXTEND ROOM 2
6. BLK(W5101) RETRACT ROOM 2
7. N/C
8. N/C
9. N/C (KEY PIN)
10. BLK(W8601) PUMP
11. RED(W6101) BATTERY
12. N/C

BLACK 12 PIN

1. N/C
2. BLK(W5002) EXTEND ROOM 3
3. BLK(W5102) RETRACT ROOM 3
4. BLK(W6813) SW. BATT ROOM 4
5. BLK(W5003) EXTEND GEN
6. BLK(W5103) RETRACT GEN
7. N/C
8. N/C
9. N/C
10. BLK(W8601) PUMP
11. RED(W6101) BATTERY
12. N/C (KEY PIN)

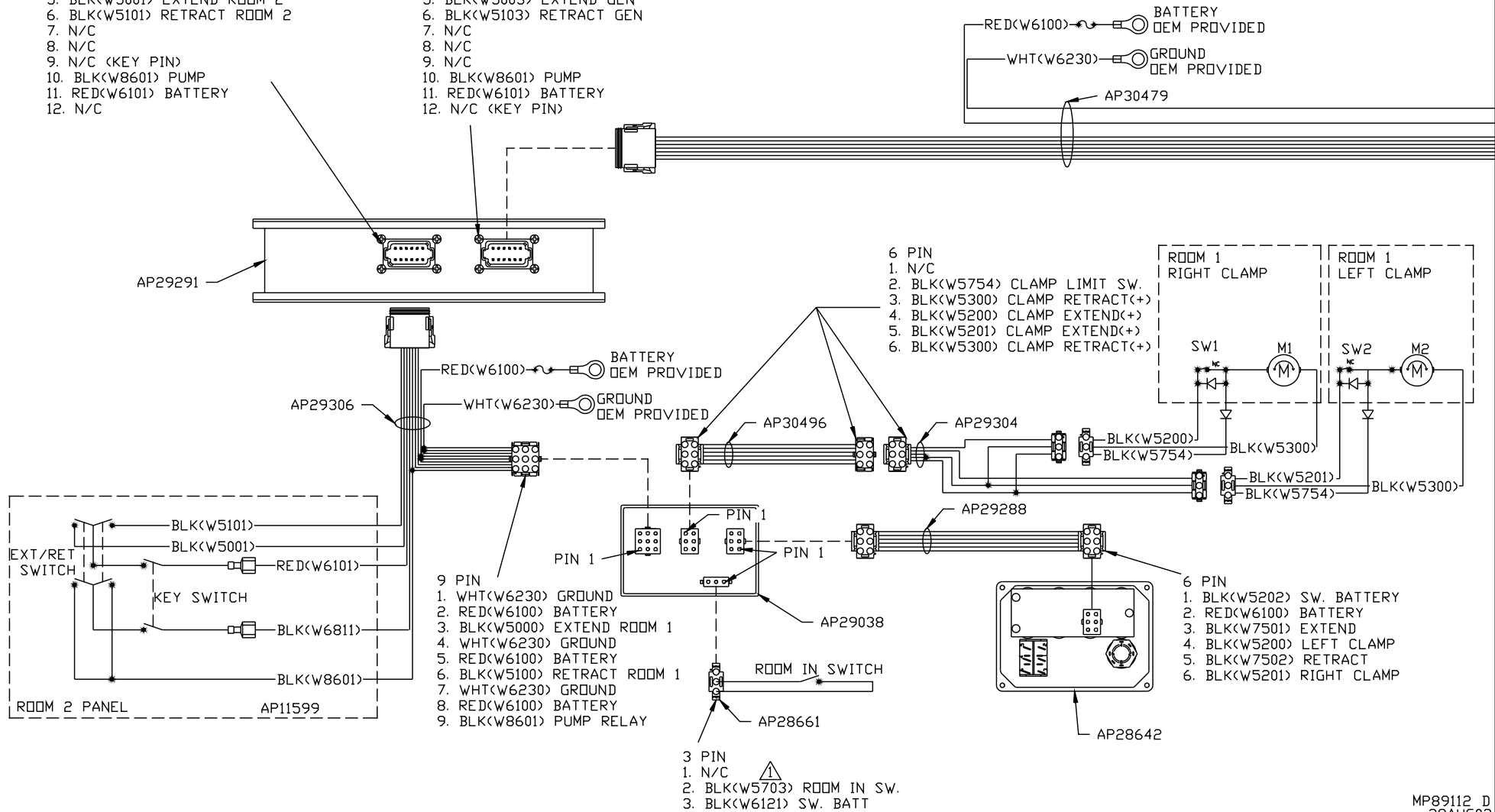

6 PIN

1. N/C
2. BLK(W5754) CLAMP LIMIT SW.
3. BLK(W5300) CLAMP RETRACT(+)
4. BLK(W5200) CLAMP EXTEND(+)
5. BLK(W5201) CLAMP EXTEND(+)
6. BLK(W5300) CLAMP RETRACT(+)

ROOM 1 RIGHT CLAMP

ROOM 1 LEFT CLAMP

9 PIN

1. WHT(W6230) GROUND
2. RED(W6100) BATTERY
3. BLK(W5000) EXTEND ROOM 1
4. WHT(W6230) GROUND
5. RED(W6100) BATTERY
6. BLK(W5100) RETRACT ROOM 1
7. WHT(W6230) GROUND
8. RED(W6100) BATTERY
9. BLK(W8601) PUMP RELAY

6 PIN

1. BLK(W5202) SW. BATTERY
2. RED(W6100) BATTERY
3. BLK(W7501) EXTEND
4. BLK(W5200) LEFT CLAMP
5. BLK(W7502) RETRACT
6. BLK(W5201) RIGHT CLAMP

3 PIN

1. N/C
2. BLK(W5703) ROOM IN SW.
3. BLK(W6121) SW. BATT

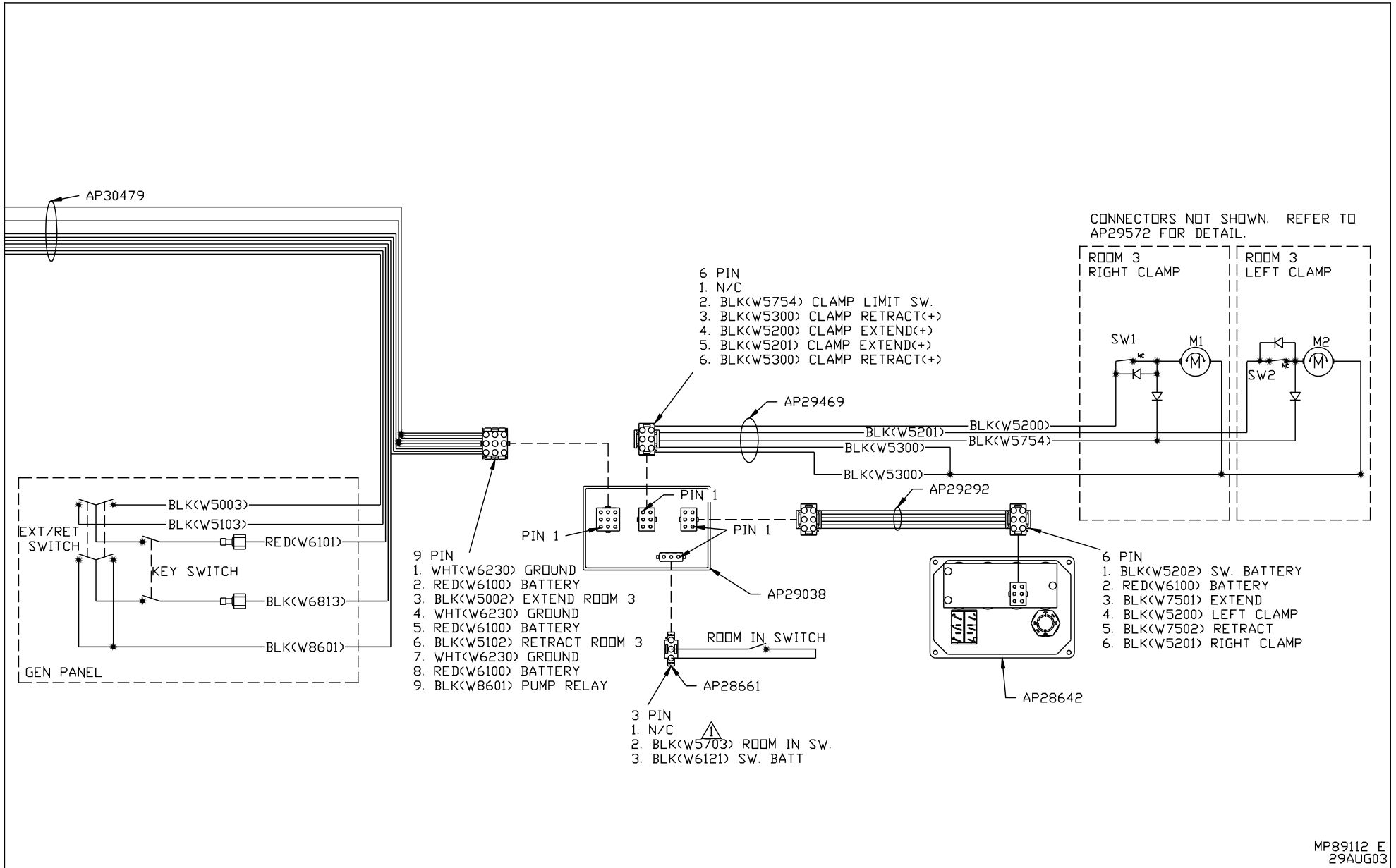

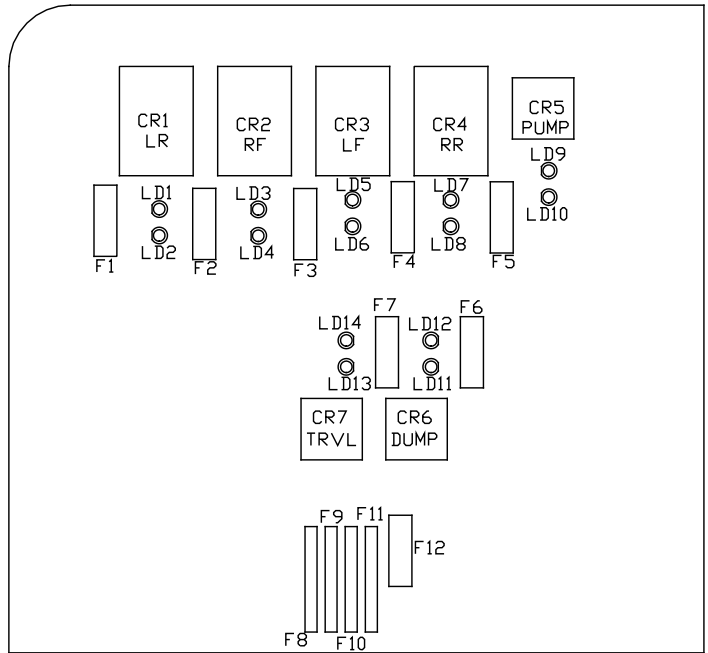

LED #	RATING	DESCRIPTION
F1	15 AMP	LEFT REAR OUTPUT
F2	15 AMP	RIGHT FRONT OUTPUT
F3	15 AMP	LEFT FRONT OUTPUT
F4	15 AMP	RIGHT REAR OUTPUT
F5	5 AMP	PUMP OUTPUT
F6	5 AMP	DUMP OUTPUT
F7	5 AMP	TRAVEL OUTPUT
F8	---	ROOM 1
F9	---	ROOM 2
F10	---	ROOM 3
F11	---	ROOM 4
F12	3	PARK BRAKE

LED #	COLOR	DESCRIPTION
LED 1	YELLOW	LR COIL
LED 2	RED	LR CONTACT
LED 3	YELLOW	RF COIL
LED 4	RED	RF CONTACT
LED 5	YELLOW	LF COIL
LED 6	RED	LF CONTACT
LED 7	YELLOW	RR COIL
LED 8	RED	RR CONTACT
LED 9	YELLOW	PUMP COIL
LED 10	RED	PUMP CONTACT
LED 11	YELLOW	DUMP COIL
LED 12	RED	DUMP CONTACT
LED 13	YELLOW	TRAVEL COIL
LED 14	RED	TRAVEL CONTACT