

AP26117 (BROWN)
PIN

- 1 N/C
- 2 BLK(W4500) LEFT REAR RAISE
- 3 BLK(W4600) LEFT REAR LOWER
- 4 BLK(W3500) RIGHT REAR RAISE
- 5 BLK(W3600) RIGHT REAR LOWER
- 6 N/C
- 7 N/C
- 8 N/C
- 9 N/C
- 10 N/C
- 11 WHT (W6258) GROUND
- 12 N/C

AP26117 (GRAY)
PIN

- 1 BLK(W6801) SW BATT
- 2 BLK(W6801) SW BATT
- 3 WHT(W6231) GROUND
- 4 WHT(W6231) GROUND

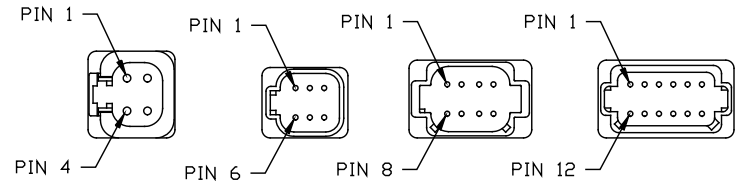

NOTE: DEUTSCH PIN NUMBERS TYPICAL UNLESS OTHERWISE NOTED

AP30922
REAR AIR/HYDRAULIC/
PRESS. AND WARN. SWITCHES

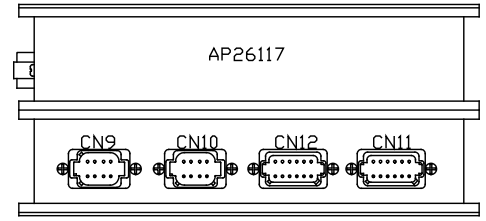
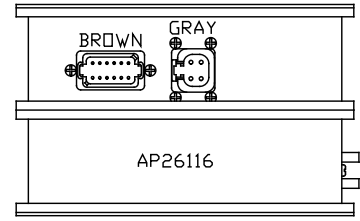

AP26116 CN9(BLACK)
PIN

- 1 N/C
- 2 N/C
- 3 RED(W6800) SW BATTERY
- 4 WHT(W6230) GROUND
- 5 CAN SHIELD
- 6 RED(W6110) IGNITION
- 7 GRN CAN LOW
- 8 YEL CAN HI

AP26116 CN10(GRAY)
PIN

- 1 N/C
- 2 N/C
- 3 N/C
- 4 N/C
- 5 N/C
- 6 N/C
- 7 N/C
- 8 N/C

AP26116 CN12(GRAY)
PIN

- 1 N/C
- 2 N/C
- 3 BLK(W3215) AIR SYSTEM PRESS. SW.
- 4 BLK(W4200) LEFT REAR AIR PRESS. SWITCH
- 5 N/C
- 6 WHT(W6231) GROUND
- 7 N/C
- 8 N/C
- 9 BLK(W4000) LEFT REAR JACK WARN. SWITCH
- 10 N/C
- 11 N/C
- 12 N/C

AP26116 CN11(GREEN)
PIN

- 1 N/C
- 2 BLK(W4210) LEFT REAR AIR PRESS. SW.
- 3 BLK(W3210) RIGHT REAR AIR PRESS. SW.
- 4 BLK(W3200) RIGHT REAR JACK PRESS. SWITCH
- 5 N/C
- 6 WHT(W6232) GROUND
- 7 N/C
- 8 N/C
- 9 BLK(W3000) RIGHT REAR JACK WARN. SWITCH
- 10 N/C
- 11 N/C
- 12 N/C

NOTE: WIRE NUMBERS ON THIS SHEET ARE REFERENCED TO HARNESS PLUGS.

			HWH I-80 EXIT 267 SOUTH RT 1 MOSCOW, IOWA 52760	
			SCALE 1:3	DATE 15MAR04
			DRAWN BY .	
1	19MAR04	UPDATED DESCRIPTIONS		
NO.	DATE	REVISION		
THE INFORMATION DISCLOSED ON THIS DRAWING IS CONFIDENTIAL AND MUST NOT BE DISCLOSED OR USED IN ANY MANNER WHICH WILL BE DETRIMENTAL TO THE HWH CORPORATION			DRAWING NUMBER MP89222 A/L	

SYSTEM SCHEMATIC ELEC

AP32492 (BROWN)

PIN
 1 N/C
 2 BLK(W1500) LEFT FRONT RAISE
 3 BLK(W1600) LEFT FRONT LOWER
 4 BLK(W2500) RIGHT FRONT RAISE
 5 BLK(W2600) RIGHT FRONT LOWER
 6 BLK(W9700) COMPRESSOR CONTROL
 7 N/C
 8 BLK(W1700) TRAVEL
 9 N/C
 10 N/C
 11 WHT(6254) GROUND
 12 N/C

AP32492 (GRAY)

PIN
 1 BLK(W6800) SW BATT
 2 BLK(W6800) SW BATT
 3 WHT(W6230) GROUND
 4 WHT(W6230) GROUND

AP32492 (BLACK)

PIN
 1 BLK(W7600) CRX1
 2 BLK(W1400) LEFT FRONT JACK
 3 BLK(W2400) RIGHT FRONT JACK
 4 N/C
 5 BLK(W3400) RIGHT REAR JACK
 6 BLK(W7601) CRX2
 7 BLK(W4400) LEFT REAR JACK
 8 N/C
 9 N/C
 10 N/C
 11 N/C
 12 N/C

AP32493 (GRAY)

PIN
 1 N/C
 2 BLK(W1210) LEFT FRONT AIR PRESS. SWITCH
 3 BLK(W2210) RIGHT FRONT AIR PRESS. SWITCH
 4 BLK(W2000) RIGHT FRONT JACK WARN. SWITCH
 5 BLK(W1000) LEFT FRONT JACK WARN. SWITCH
 6 WHT(W6230) GROUND
 7 N/C
 8 N/C
 9 BLK(W2200) RIGHT FRONT JACK PRESS. SWITCH
 10 BLK(W1200) LEFT FRONT JACK PRESS. SWITCH
 11 N/C
 12 N/C

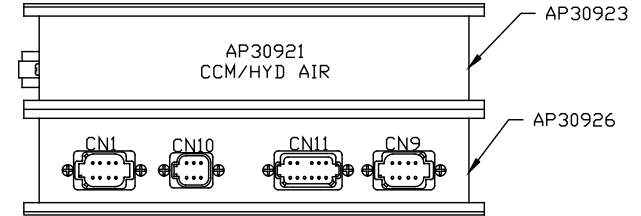
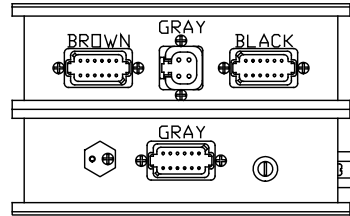

AP32493 CN1 (BLACK)

PIN
 1 N/C
 2 N/C
 3 RED(W6800) SWITCHED BATTERY
 4 WHT(W6230) GROUND
 5 CAN SHIELD
 6 RED(W6110) IGNITION
 7 GRN CAN LOW
 8 YEL CAN HI

AP32493 CN10 (GRAY)

PIN
 1 BLK(W7599) SWITCH LIGHT CONTROL
 2 RED(W6100) RESET OUT
 3 BLK(W7550) RESET IN
 4 RED(W6121) WARN LIGHT SUPPLY
 5 WHT(W6230) SWITCH LIGHT SUPPLY
 6 BLK(W7699) WARN LIGHT/BUZZER CONTROL

AP32493 CN11 (GRAY)

PIN
 1 RED(W6110) IGNITION
 2 N/C
 3 N/C
 4 N/C
 5 RED(W6120) ACCESSORY
 6 RED(W6100) COACH BATTERY
 7 WHT(W6230) GROUND
 8 N/C
 9 N/C
 10 N/C
 11 BLK(W9000) PARK BRAKE SWITCH
 12 RED(W6101) ENGINE BATTERY

AP32493 CN9 (GREEN)

PIN
 1 BLK(W8500) MASTER RELAY CNTRL
 2 BLK(W8100) 3000 LB PSW.
 3 BLK(W8101) 50 LB PSW
 4 BLK(W8600) PMP RELAY CNTRL
 5 N/C
 6 BLK(W9901) SW BATT FROM PUMP RELAY
 7 N/C
 8 N/C

NOTE: WIRE NUMBERS ON THIS SHEET ARE REFERENCED TO HARNESS PLUGS.

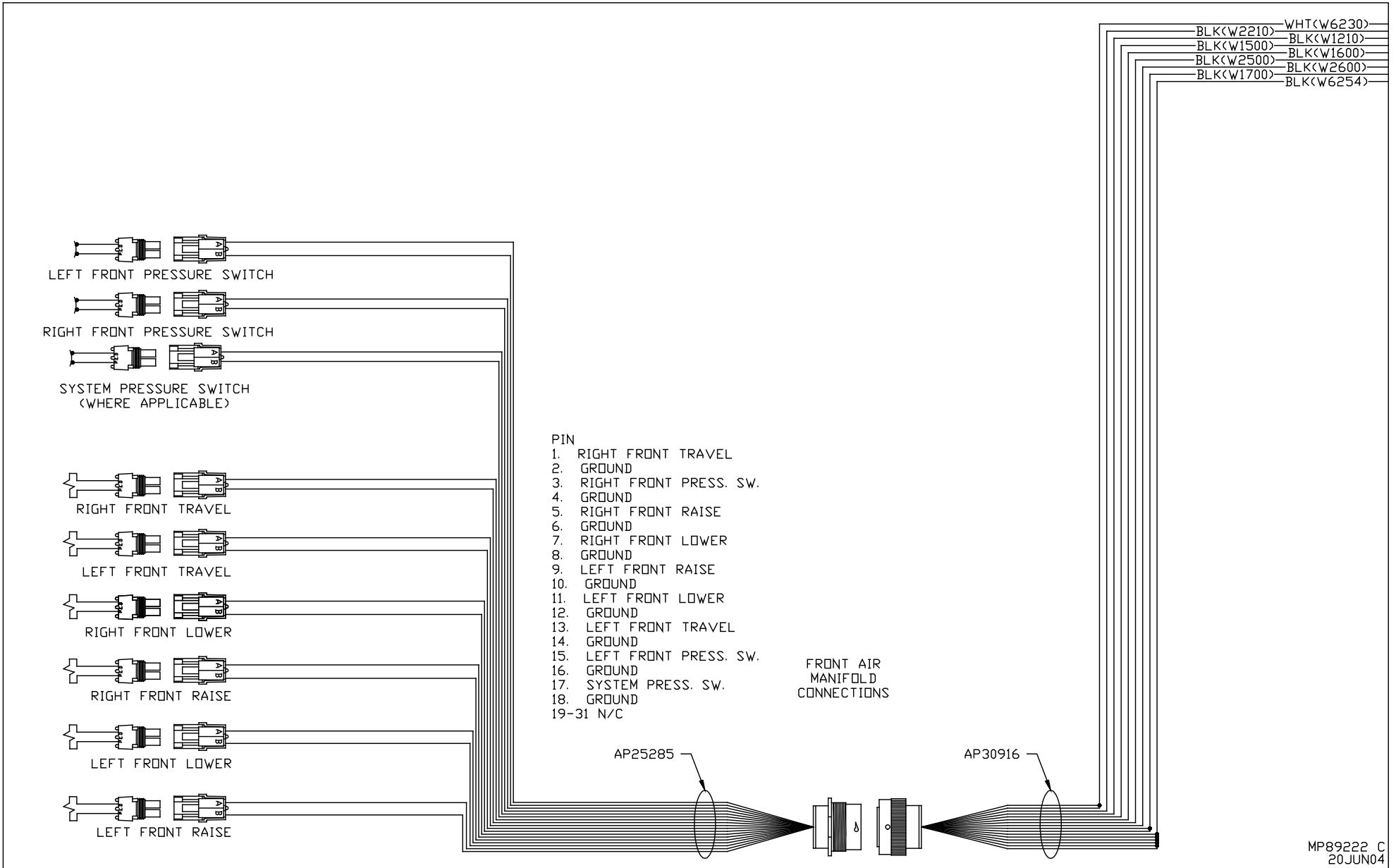

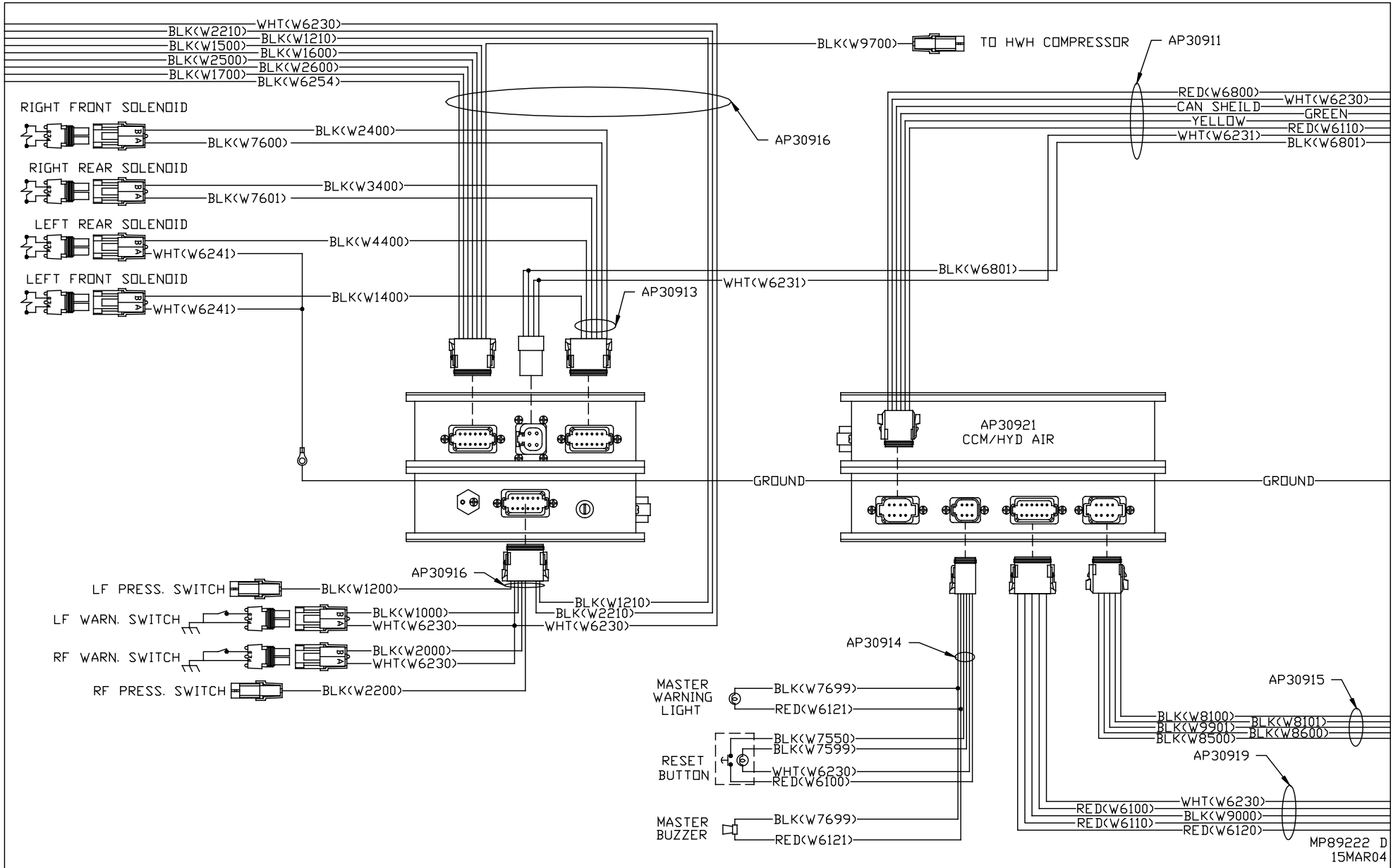

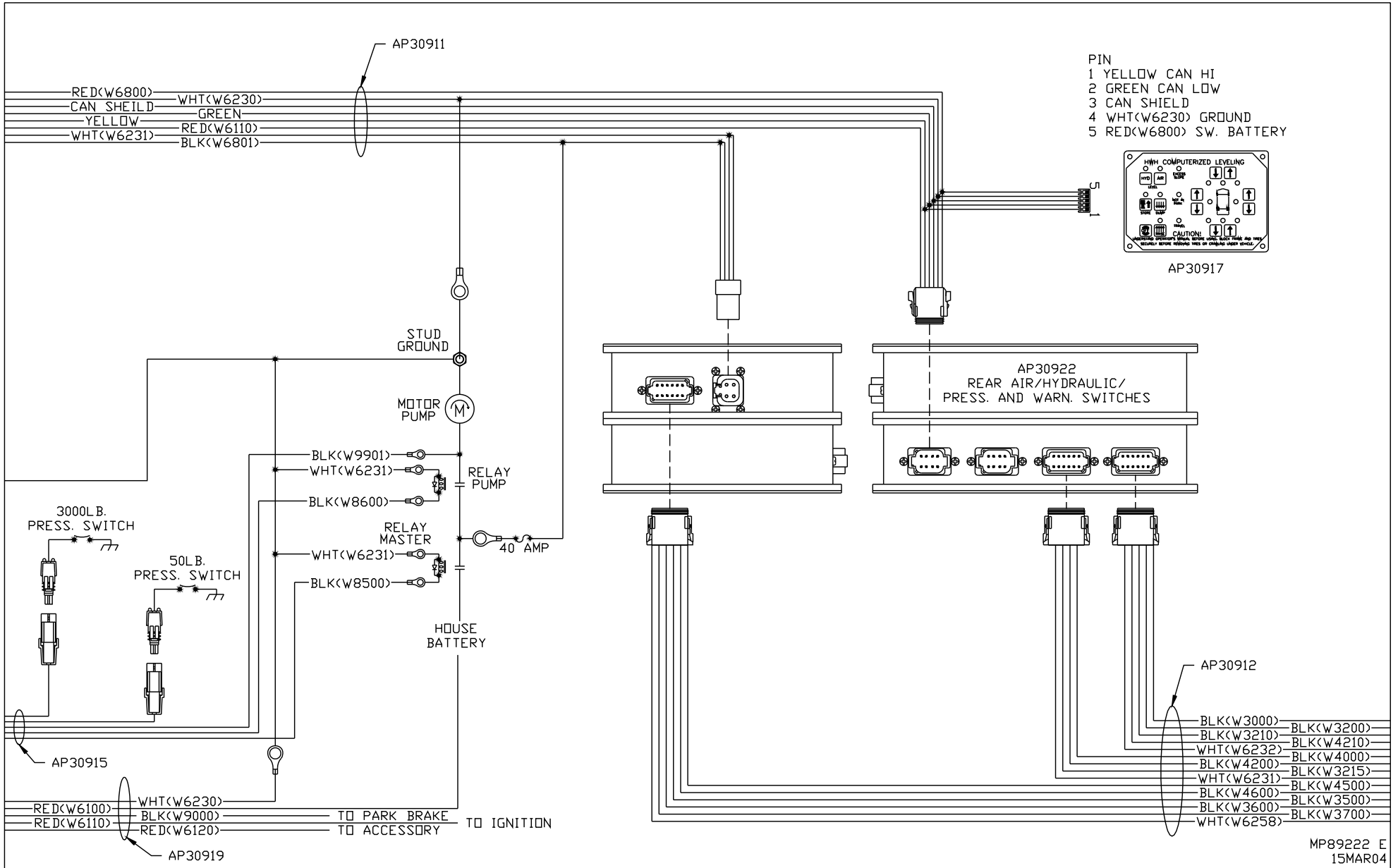

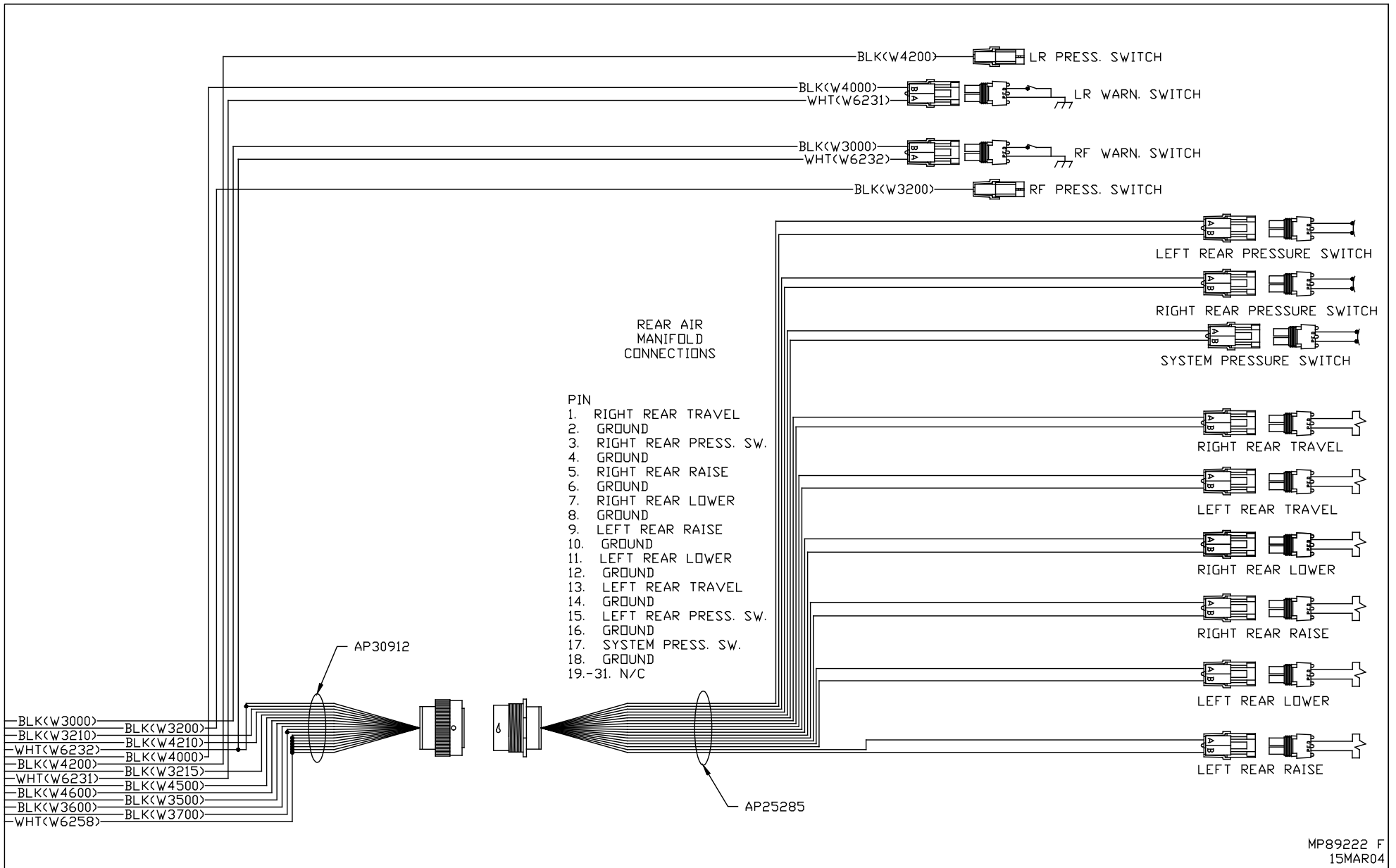

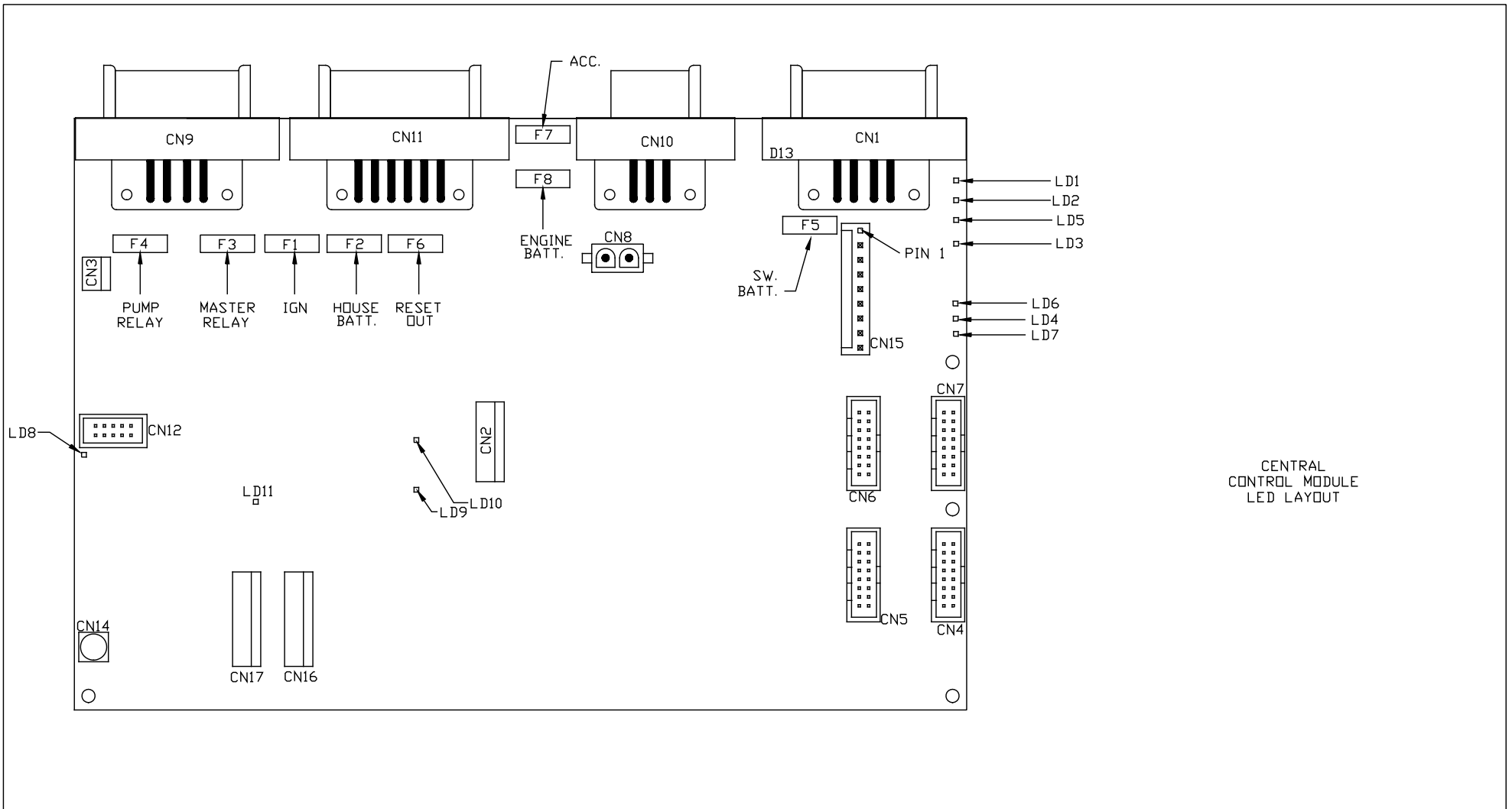

LED #	CONNECTOR	COLOR	DESCRIPTION
LED 1	CN 9 PIN 1	RED	MASTER RELAY
LED 2	CN 9 PIN 4	RED	PUMP RELAY
LED 3	CN 1 PIN 3	RED	SW 12V
LED 4	CN 11 PIN 12	RED	ENGINE BATT
LED 5	CN 9 PIN 5	RED	SPEED SWITCH
LED 6	NOT USED	NOT USED	NOT USED

LED #	CONNECTOR	COLOR	DESCRIPTION
LED 7	CN 1 PIN 7 & 8	RED	LINK LIGHT
LED 8	CN 11 PIN 8 & 9	RED	NEUTRAL HOLD
LED 9	NOT USED	NOT USED	NOT USED
LED 10	CN9 PIN 2	RED	3000 LBS. PSW
LED 11	CN11 PIN 11	RED	PARK BRAKE
	CN15 PIN 1	NOT USED	SYSTEM WAKE UP

MP89222 G
15MAR04

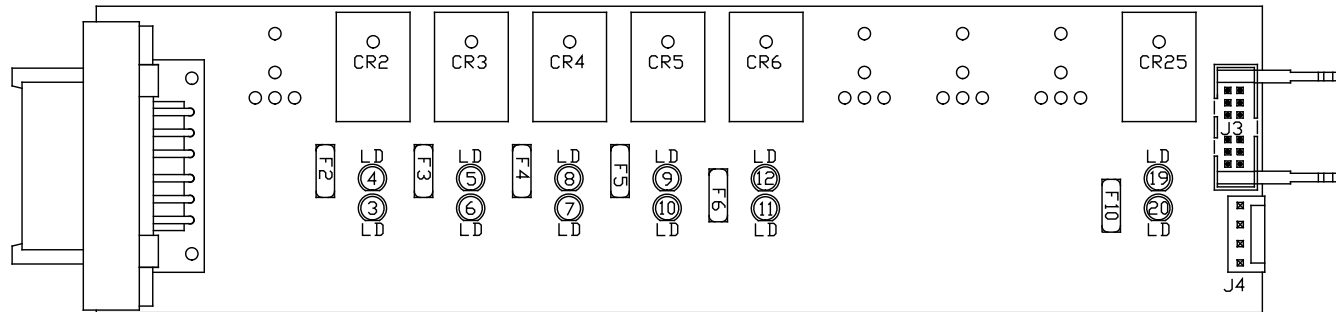

FRONT AIR
LED LAYOUT

LED #	COLOR	INPUT J3	FUSE #	OUTPUT	RELAY #	DESCRIPTION
LED1	---	---	---	---	---	---
LED2	---	---	---	---	---	---
LED3	RED	---	FUSE 2	PIN 2	CR2	LEFT FRONT RAISE (CONTACT)
LED4	YELLOW	PIN 12	---	---	CR2	LEFT FRONT RAISE (COIL)
LED5	YELLOW	PIN 11	---	---	CR3	LEFT FRONT LOWER (COIL)
LED6	RED	---	FUSE 3	PIN 3	CR3	LEFT FRONT LOWER (CONTACT)
LED7	RED	---	FUSE 4	PIN 4	CR4	RIGHT FRONT RAISE (CONTACT)
LED8	YELLOW	PIN 10	---	---	CR4	RIGHT FRONT RAISE (COIL)
LED9	YELLOW	PIN 9	---	---	CR5	RIGHT FRONT LOWER (COIL)
LED10	RED	---	FUSE 5	PIN 5	CR5	RIGHT FRONT LOWER (CONTACT)
LED11	RED	---	FUSE 6	PIN 6	CR6	COMPRESSOR (CONTACT)
LED12	YELLOW	PIN 8	---	---	CR6	COMPRESSOR (COIL)
LED13	---	---	---	---	---	---
LED14	---	---	---	---	---	---
LED15	---	---	---	---	---	---
LED16	---	---	---	---	---	---
LED17	---	---	---	---	---	---
LED18	---	---	---	---	---	---
LED19	YELLOW	PIN 4	---	---	CR25	TRAVEL (COIL)
LED20	RED	---	FUSE 10	PIN 8	CR25	TRAVEL (CONTACT)

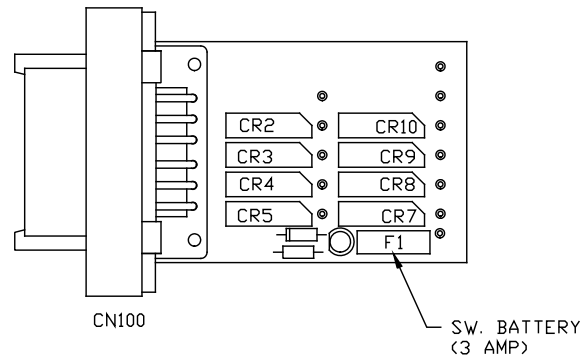

CONNECTOR	READ SWITCH	DESCRIPTION
CN 100 PIN 1	---	NOT USED
CN 100 PIN 2	CR2	AIR LF PSW
CN 100 PIN 3	CR3	AIR RF PSW
CN 100 PIN 4	CR4	RF WARNING
CN 100 PIN 5	CR5	LF WARNING
CN 100 PIN 6	---	GROUND

CONNECTOR	READ SWITCH	DESCRIPTION
CN 100 PIN 7	---	NOT USED
CN 100 PIN 8	CR7	NOT USED
CN 100 PIN 9	CR8	HYD RF PSW
CN 100 PIN 10	CR9	HYD LF PSW
CN 100 PIN 11	CR10	NOT USED
CN 100 PIN 12	---	NOT USED

MP89222 I
15MAR04

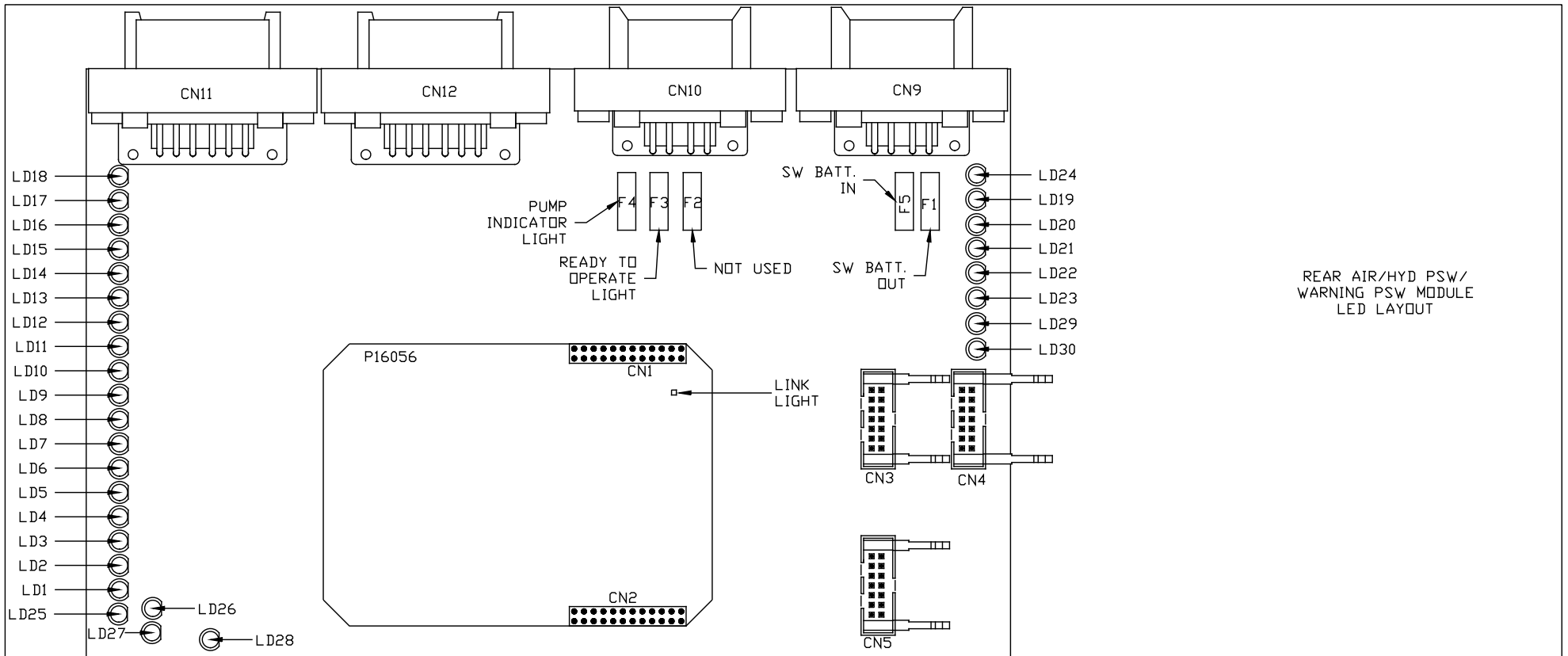

LED #	CONNECTOR	COLOR	DESCRIPTION	LED #	CONNECTOR	COLOR	DESCRIPTION
LED 1	NOT USED	RED	NOT USED	LED 16	CN12 PIN 4	GREEN	HYD LR PSW
LED 2	NOT USED	RED	RETRACT	LED 17	CN11 PIN 9	GREEN	HYD RR WARN
LED 3	NOT USED	GREEN	NOT USED	LED 18	CN12 PIN 9	GREEN	HYD LR WARN
LED 4	NOT USED	YELLOW	NOT USED	LED 19	CN11/CN12 PIN 7	RED	12V OUTPUT
LED 5	CN11 PIN 2	YELLOW	AIR LR PSW	LED 20	CN9 PIN 3	RED	SW BATT
LED 6	NOT USED	YELLOW	NOT USED	LED 21	NOT USED	RED	NOT USED
LED 7	CN11 PIN 3	GREEN	AIR RR PSW	LED 22	NOT USED	RED	NOT USED
LED 8	CN12 PIN 3	GREEN	SYSTEM AIR PSW	LED 23	NOT USED	RED	NOT USED
LED 9	NOT USED	GREEN	NOT USED	LED 24	NOT USED	RED	NOT USED
LED 10	NOT USED	GREEN	NOT USED	LED 25	NOT USED	RED	NOT USED
LED 11	NOT USED	YELLOW	NOT USED	LED 26	NOT USED	RED	NOT USED
LED 12	NOT USED	YELLOW	NOT USED	LED 27	NOT USED	RED	NOT USED
LED 13	NOT USED	YELLOW	NOT USED	LED 28	NOT USED	RED	NOT USED
LED 14	NOT USED	YELLOW	NOT USED	LED 29	NOT USED	RED	NOT USED
LED 15	CN11 PIN 4	GREEN	HYD RR PSW	LED 30	NOT USED	RED	NOT USED

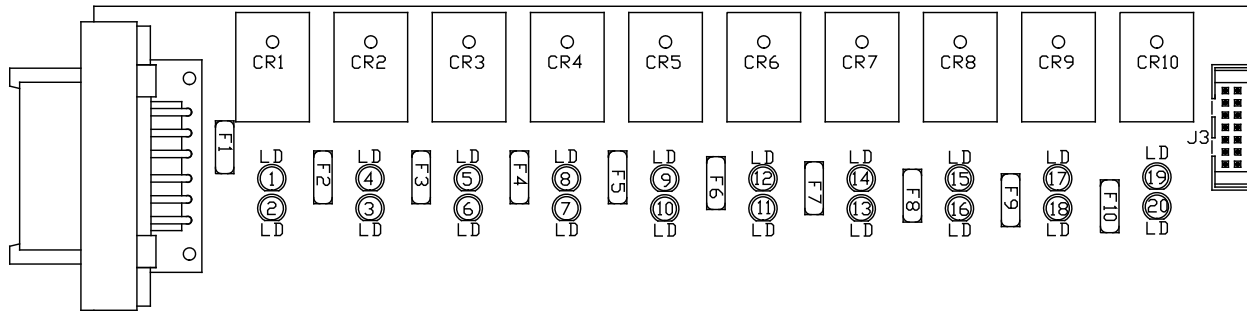

REAR AIR
LED LAYOUT

LED #	COLOR	INPUT J3	FUSE #	OUTPUT	RELAY #	DESCRIPTION
LED1	YELLOW	PIN 13	---	---	CR1	TAG LIFT (COIL)
LED2	RED	---	FUSE 1	PIN 1	CR1	TAG LIFT (CONTACT)
LED3	RED	---	FUSE 2	PIN 2	CR2	LEFT REAR RAISE (CONTACT)
LED4	YELLOW	PIN 12	---	---	CR2	LEFT REAR RAISE (COIL)
LED5	YELLOW	PIN 11	---	---	CR3	LEFT REAR LOWER (COIL)
LED6	RED	---	FUSE 3	PIN 3	CR3	LEFT REAR LOWER (CONTACT)
LED7	RED	---	FUSE 4	PIN 4	CR4	RIGHT REAR RAISE (CONTACT)
LED8	YELLOW	PIN 10	---	---	CR4	RIGHT REAR RAISE (COIL)
LED9	YELLOW	PIN 9	---	---	CR5	RIGHT REAR LOWER (COIL)
LED10	RED	---	FUSE 5	PIN 5	CR5	RIGHT REAR LOWER (CONTACT)
LED11	RED	---	FUSE 6	PIN 6	CR6	NOT USED
LED12	YELLOW	PIN 8	---	---	CR6	NOT USED
LED13	RED	---	FUSE 7	PIN 10	CR7	TAG LEFT REAR LOWER (CONTACT)
LED14	YELLOW	PIN 7	---	---	CR7	TAG LEFT REAR LOWER (COIL)
LED15	YELLOW	PIN 6	---	---	CR8	TAG RIGHT REAR LOWER (COIL)
LED16	RED	---	FUSE 8	PIN 9	CR8	TAG RIGHT REAR LOWER (CONTACT)
LED17	YELLOW	PIN 5	---	---	CR9	TAG TRAVEL (COIL)
LED18	RED	---	FUSE 9	PIN 7	CR9	TAG TRAVEL (CONTACT)
LED19	YELLOW	PIN 4	---	---	CR10	TRAVEL (COIL)
LED20	RED	---	FUSE 10	PIN 8	CR10	TRAVEL (CONTACT)

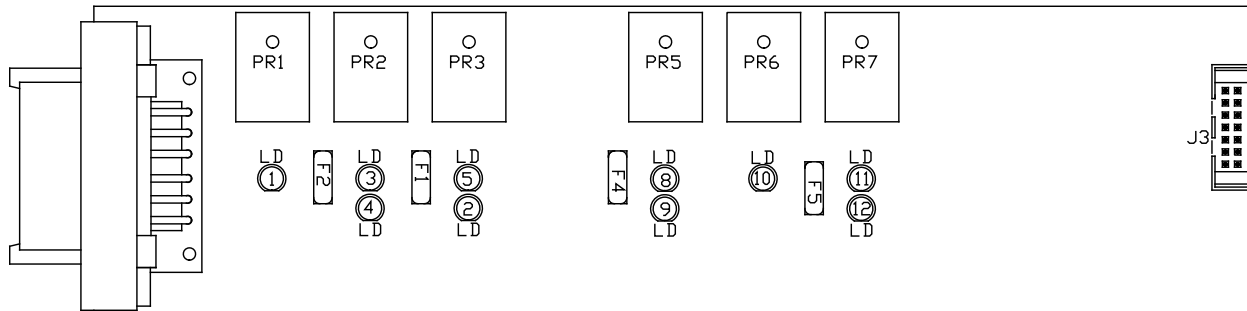

LED #	COLOR	INPUT J3	FUSE #	OUTPUT	RELAY #	DESCRIPTION
LED1	YELLOW	PIN 13	---	PIN 1	PR1	CRX1 (COIL)
LED2	RED	PIN 11	F1	PIN 3	PR3	RF JACK (CONTACT)
LED3	YELLOW	PIN 12	---	---	PR2	LF JACK (COIL)
LED4	RED	---	F2	PIN 2	PR2	LF JACK (CONTACT)
LED5	YELLOW	PIN 11	---	---	PR3	RF JACK (COIL)
LED6	YELLOW	PIN 10	---	---	---	---
LED7	RED	---	---	---	---	---
LED8	YELLOW	PIN 9	---	---	PR5	RR JACK (COIL)
LED9	RED	---	F4	PIN 5	PR5	RR JACK (CONTACT)
LED10	YELLOW	PIN 8	---	PIN 6	PR6	CRX2 (COIL)
LED11	YELLOW	PIN 7	---	---	PR7	LR JACK (COIL)
LED12	RED	---	F5	PIN 7	PR7	LR JACK (CONTACT)
LED13	---	---	---	---	---	---
LED14	---	---	---	---	---	---
LED15	---	---	---	---	---	---
LED16	---	---	---	---	---	---
LED17	---	---	---	---	---	---
LED18	---	---	---	---	---	---

LEVELING
LED LAYOUT