

- PIN
1. YELLOW CAN HIGH
 2. GREEN CAN LOW
 3. CAN SHIELD
 4. WHT(W6230) GROUND
 5. RED(W6800) SW. BATTERY

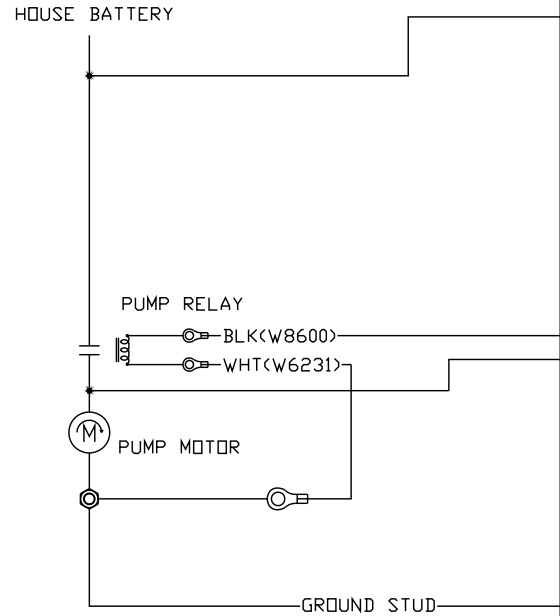
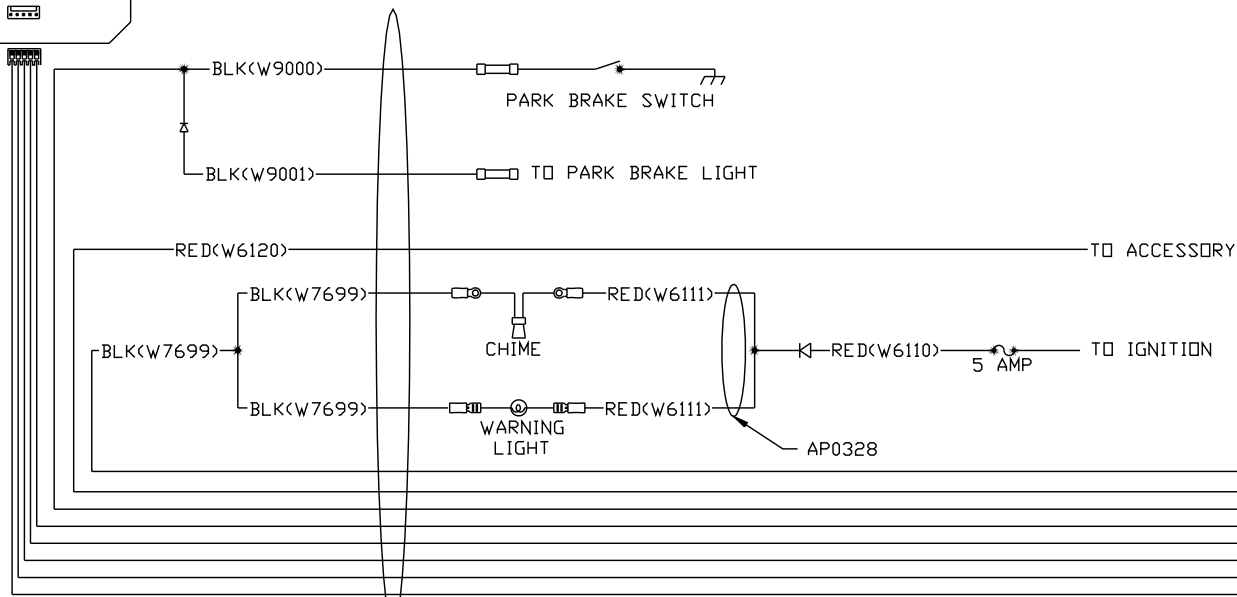

- BLK(W7699)
- RED(W6120)
- BLK(W9000)
- YELLOW
- GREEN
- SHIELD
- WHITE(W6230)
- RED(W6800)

AP33863

| | | |
|---------|----------------------|----------|
| | | |
| 28APR06 | WAS W5702 | |
| 03JUN05 | WAS AP29304, AP30496 | |
| 07DEC04 | CHANGED HARNESS | |
| NO. | DATE | REVISION |

HWH I-80 EXIT 267 SOUTH
RT 1 MOSCOW, IOWA 52760

SCALE 1:3 DATE 15JUL04 DRAWN BY

SYSTEM SCHEMATIC ELEC

THE INFORMATION DISCLOSED ON THIS DRAWING IS CONFIDENTIAL AND MUST NOT BE DISCLOSED OR USED IN ANY MANNER WHICH WILL BE DETRIMENTAL TO THE HWH CORPORATION

DRAWING NUMBER
MP89278 A/G

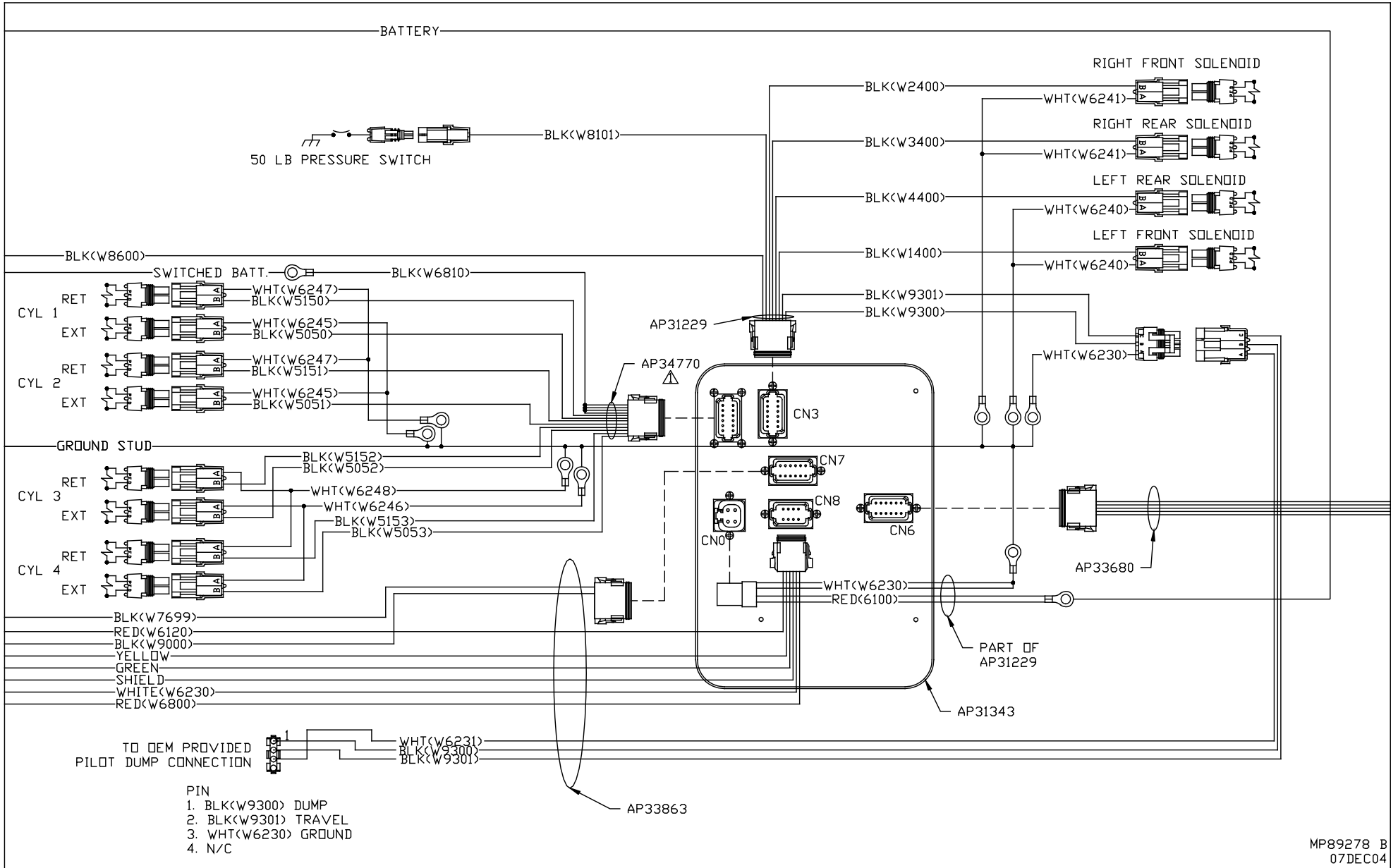

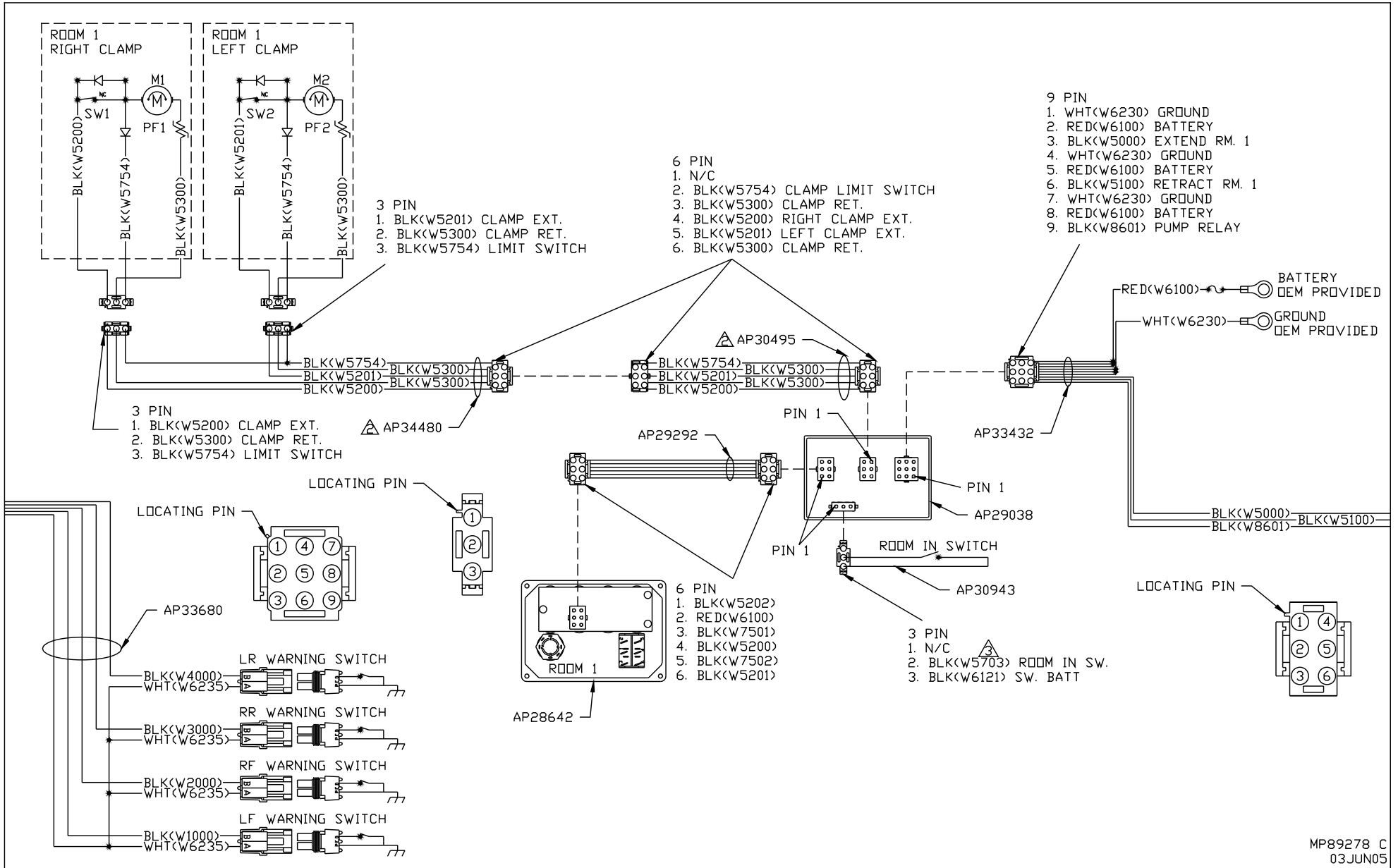

BLACK 12 PIN

1. N/C
2. BLK(W5000) EXTEND ROOM 1
3. BLK(W5100) RETRACT ROOM 1
4. BLK(W6811) SWITCHED BATT. ROOM 2
5. BLK(W5001) EXTEND ROOM 2
6. BLK(W5101) RETRACT ROOM 2
7. N/C
8. KEY PIN
9. N/C
10. BLK(W8601) PUMP
11. RED(W6101) BATTERY
12. KEY PIN

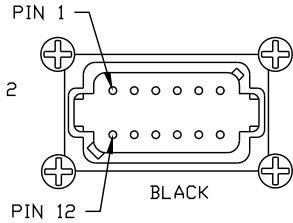

BLACK 12 PIN

1. N/C
2. BLK(W5002) EXTEND RM. 3
3. BLK(W5102) RETRACT RM. 3
4. N/C
5. BLK(W5003) EXTEND RM. 4
6. BLK(W5103) RETRACT RM. 4
7. N/C
8. KEY PIN
9. KEY PIN
10. BLK(W8601) PUMP
11. N/C
12. N/C

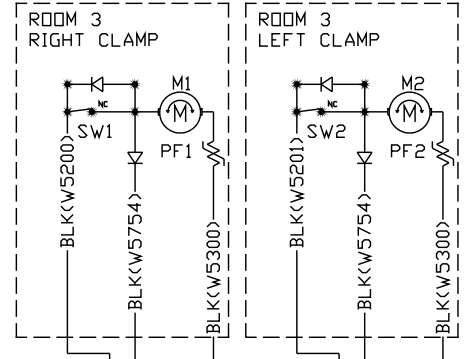

- 3 PIN
1. BLK(W5201) CLAMP EXT.
 2. BLK(W5300) CLAMP RET.
 3. BLK(W5754) LIMIT SWITCH

- 3 PIN
1. BLK(W5200) CLAMP EXT.
 2. BLK(W5300) CLAMP RET.
 3. BLK(W5754) LIMIT SWITCH

- 6 PIN
1. BLK(W5202)
 2. RED(W6100)
 3. BLK(W7501)
 4. BLK(W5200)
 5. BLK(W7502)
 6. BLK(W5201)

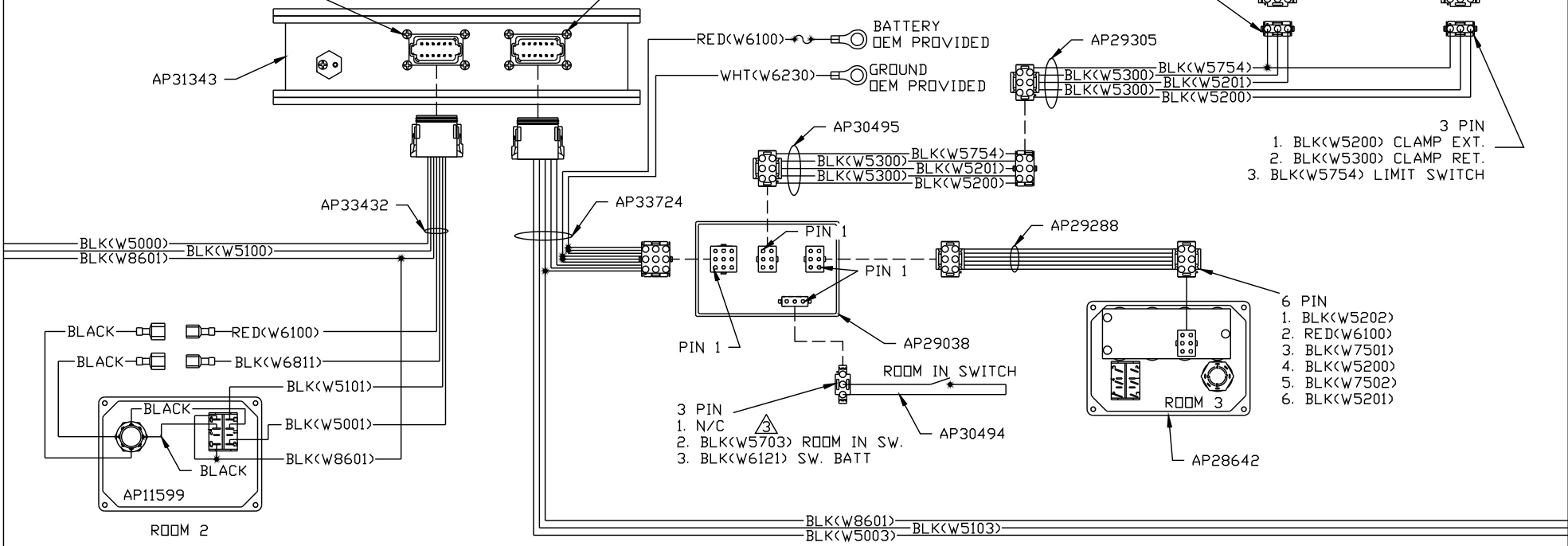

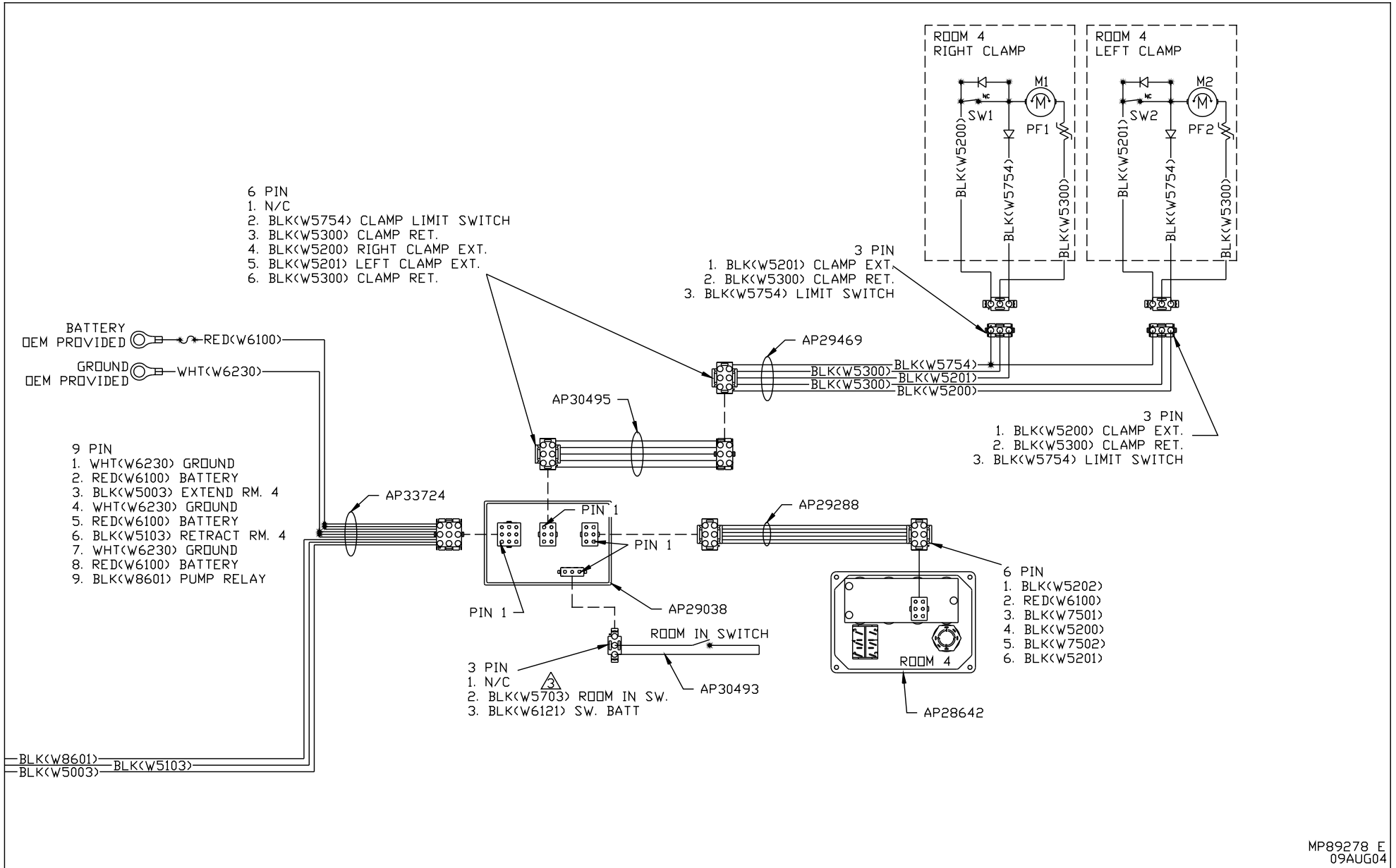

GREEN 12 PIN

1. BLK(W5050) CYL EXT. ROOM 1
2. BLK(W5150) CYL RET. ROOM 1
3. BLK(W5151) CYL RET. ROOM 2
4. BLK(W5051) CYL EXT. ROOM 2
5. BLK(W5052) CYL EXT. ROOM 3
6. BLK(W5152) CYL RET. ROOM 3
7. BLK(W5053) CYL EXT. ROOM 4
8. BLK(W5153) CYL RET. ROOM 4
9. BLK(W6810) SW. BATTERY
10. BLK(W6810) SW. BATTERY
11. BLK(W6810) SW. BATTERY
12. BLK(W6810) SW. BATTERY

CN3 (BROWN)

- PIN
- 1 N/C
 - 2 N/C
 - 3 BLK(W8101) 50 LB PRESS SW
 - 4 N/C
 - 5 BLK(W1400) LF SOLENOID
 - 6 N/C
 - 7 N/C
 - 8 BLK(W4400) LR SOLENOID
 - 9 BLK(W3400) RR SOLENOID
 - 10 BLK(W2400) RF SOLENOID
 - 11 N/C
 - 12 BLK(W8600) PUMP RELAY CONTROL

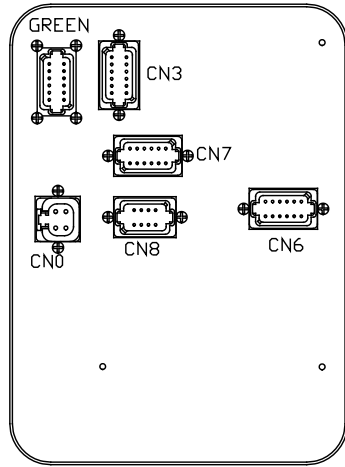
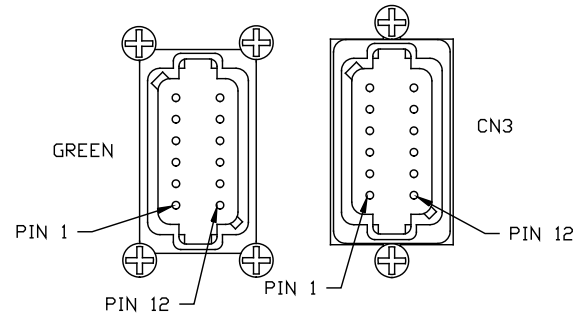

CN12 (BLACK)

- PIN
- 1 N/C
 - 2 N/C
 - 3 N/C
 - 4 N/C
 - 5 N/C
 - 6 N/C
 - 7 BLK(W9000) PARK BRAKE
 - 8 N/C
 - 9 N/C
 - 10 N/C
 - 11 BLK(W7699) WARN/BUZZER CONTROL
 - 12 N/C

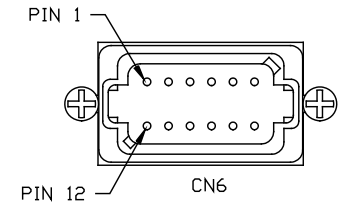
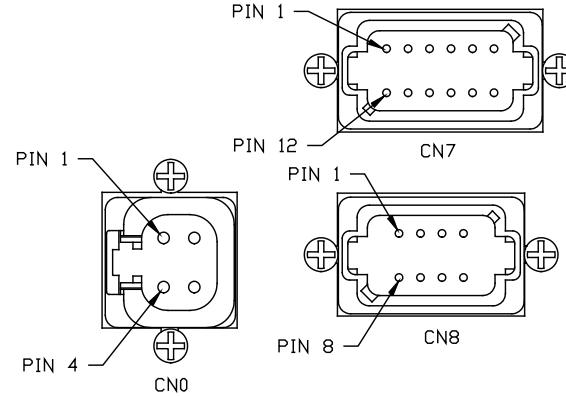

NOTE: WIRE NUMBERS ON THIS PAGE REFER TO HARNESS PLUGS.

CN0 (GRAY)

- PIN
- 1 RED(W6100) BATT
 - 2 RED(W6100) BATT
 - 3 WHT(W6230) GROUND
 - 4 WHT(W6230) GROUND

CN8 (BLACK)

- PIN
- 1 N/C
 - 2 N/C
 - 3 RED(W6800) SW BATT
 - 4 WHT(W6230) GROUND
 - 5 CAN SHIELD
 - 6 RED(W6120) ACCESSORY
 - 7 GREEN
 - 8 YELLOW

CN6 (GRAY)

- PIN
- 1 N/C
 - 2 N/C
 - 3 BLK(W1000) LF WARN SW
 - 4 BLK(W2000) RF WARN SW
 - 5 BLK(W1200) LF PRESS SW
 - 6 BLK(W2200) RF PRESS SW
 - 7 BLK(W3200) RR PRESS SW
 - 8 BLK(W4200) LR PRESS SW
 - 9 BLK(W3000) RR WARN SW
 - 10 BLK(W4000) LR WARN SW
 - 11 N/C
 - 12 WHT(W6235) GROUND

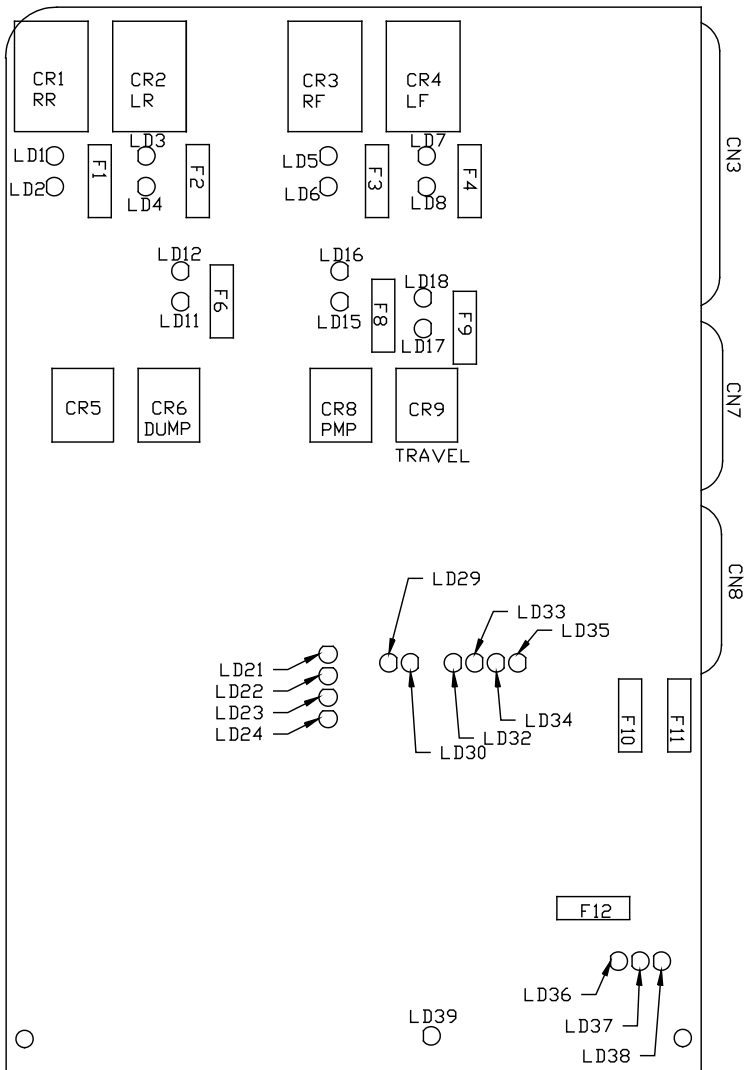

| LED # | COLOR | DESCRIPTION |
|--------|--------|------------------------|
| LED 1 | YELLOW | RR COIL |
| LED 2 | RED | RR CONTACT |
| LED 3 | YELLOW | LR COIL |
| LED 4 | RED | LR CONTACT |
| LED 5 | YELLOW | RF COIL |
| LED 6 | RED | RF CONTACT |
| LED 7 | YELLOW | LF COIL |
| LED 8 | RED | LF CONTACT |
| LED 9 | YELLOW | --- |
| LED 10 | RED | --- |
| LED 11 | YELLOW | DUMP COIL |
| LED 12 | RED | DUMP CONTACT |
| LED 13 | --- | --- |
| LED 14 | --- | --- |
| LED 15 | YELLOW | PUMP COIL |
| LED 16 | RED | PUMP CONTACT |
| LED 17 | YELLOW | TRAVEL COIL |
| LED 18 | RED | TRAVEL CONTACT |
| LED 19 | --- | --- |
| LED 20 | --- | --- |
| LED 21 | YELLOW | LF WARN SW |
| LED 22 | YELLOW | RF WARN SW |
| LED 23 | YELLOW | RR WARN SW |
| LED 24 | YELLOW | LR WARN SW |
| LED 25 | --- | --- |
| LED 26 | --- | --- |
| LED 27 | --- | --- |
| LED 28 | --- | --- |
| LED 29 | RED | NOT USED |
| LED 30 | YELLOW | NOT USED |
| LED 31 | --- | --- |
| LED 32 | RED | MASTER WARNING CONTROL |
| LED 33 | GREEN | 50 LB PSW INPUT |
| LED 34 | RED | JACK INTERRUPT |
| LED 35 | RED | PARK BRAKE |
| LED 36 | RED | BOARD ENABLED |
| LED 37 | RED | ACCESSORY IN |
| LED 38 | RED | ACCESSORY OUT |
| LED 39 | RED | LINK LIGHT |

| FUSE | RATING | DESCRIPTION |
|------|---------|------------------|
| F1 | 15 AMP | RR OUTPUT |
| F2 | 15 AMP | LR OUTPUT |
| F3 | 15 AMP | RF OUTPUT |
| F4 | 15 AMP | LF OUTPUT |
| F5 | --- | --- |
| F6 | 5 AMP | DUMP |
| F7 | --- | --- |
| F8 | 5 AMP | PUMP OUTPUT |
| F9 | 5 AMP | TRAVEL OUTPUT |
| F10 | 7.5 AMP | ACC INPUT |
| F11 | 3 AMP | WARN LITE SUPPLY |
| F12 | 10 AMP | ACC OUTPUT |