

- PIN
1. YELLOW CAN HIGH
 2. GREEN CAN LOW
 3. CAN SHIELD
 4. WHT(W6230) GROUND
 5. RED(W6800) SW. BATTERY

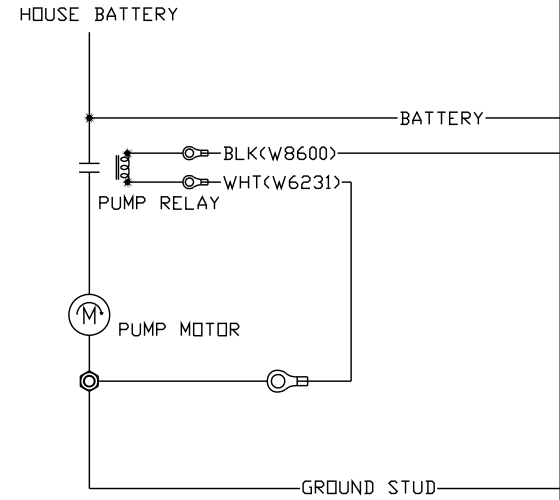
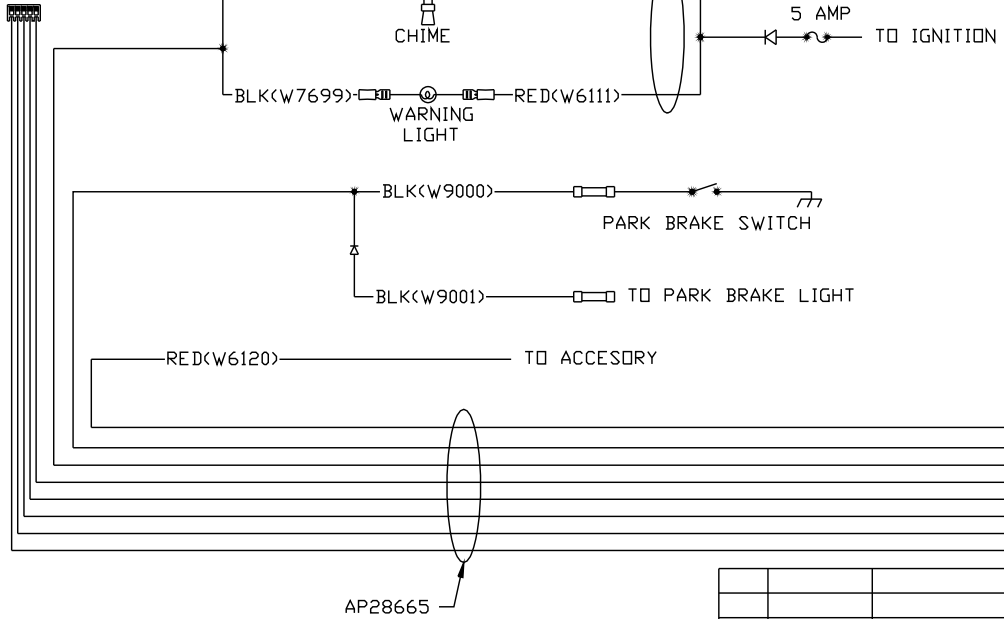

- RED(W6120)
- BLK(W9000)
- BLK(W7699)
- YELLOW
- GREEN
- SHIELD
- WHITE(W6230)
- RED(W6800)

AP28665

NO.	DATE	REVISION
1	26NOV07	ADDED NOTE, WAS A/E

HW H I-80 EXIT 267 SOUTH
RT 1 MOSCOW, IOWA 52760

SCALE 1:3 DATE 24MAY05 DRAWN BY .

SYSTEM SCHEMATIC ELEC

NOTE: INSTALLATION MUST CONFORM TO GOOD SHOP PRACTICES, SAE STANDARDS, RVIA STANDARDS, AND OTHER APPLICABLE STANDARDS.

THE INFORMATION DISCLOSED ON THIS DRAWING IS CONFIDENTIAL AND MUST NOT BE DISCLOSED OR USED IN ANY MANNER WHICH WILL BE DETRIMENTAL TO THE HW H CORPORATION

DRAWING NUMBER
MP89474 A/D

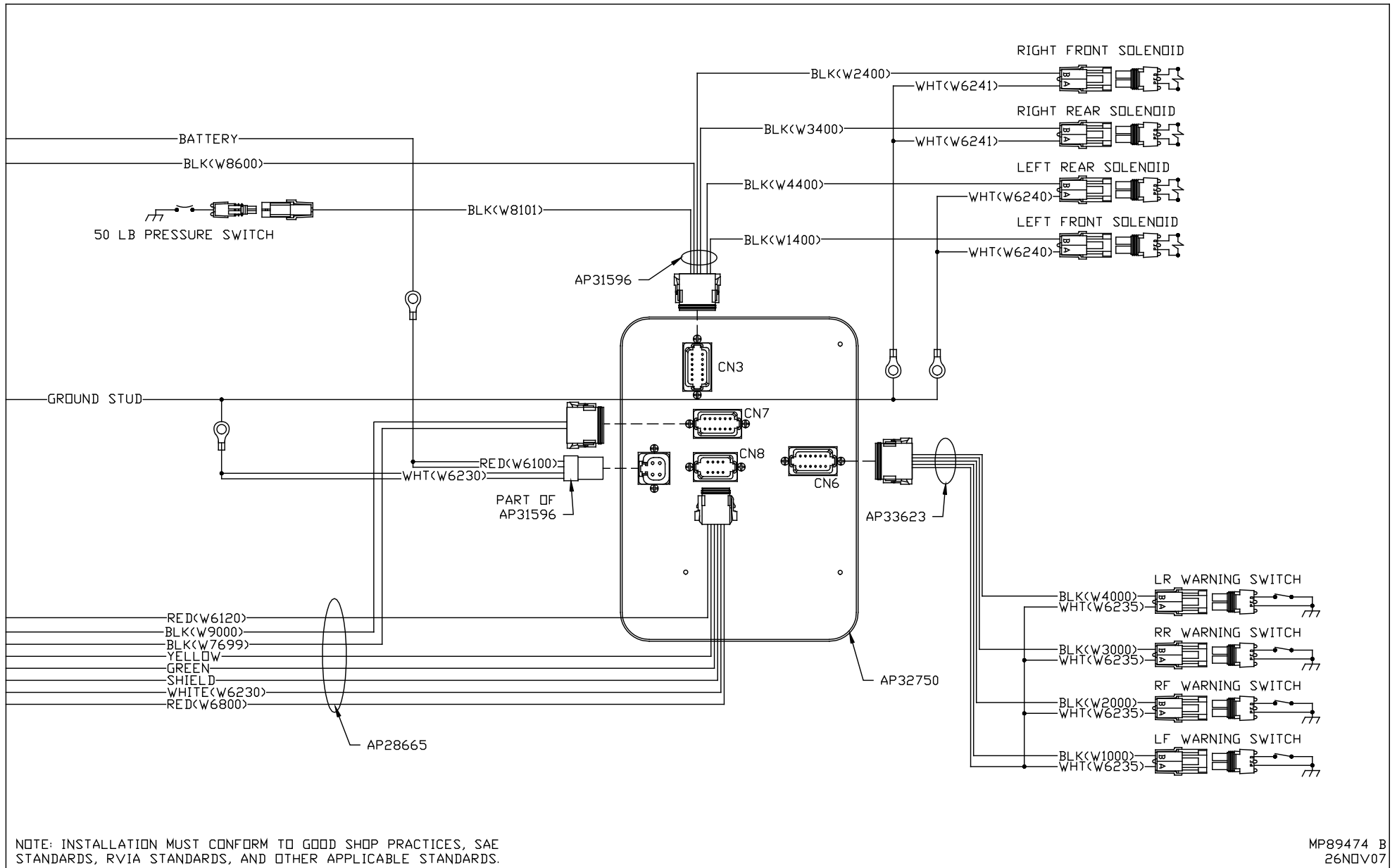

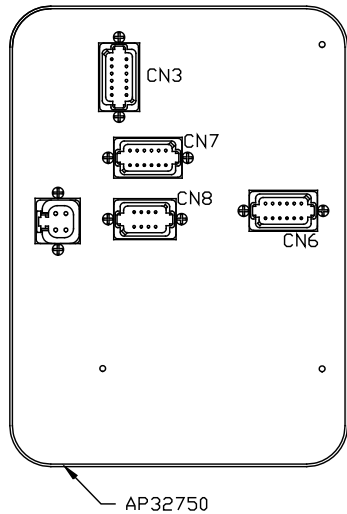

BROWN (CN3)
 PIN
 1 N/C
 2 N/C
 3 BLK(W8101) 50 LB PRESS SW
 4 N/C
 5 BLK(W1400) LF SOLENOID
 6 N/C
 7 N/C
 8 BLK(W4400) LR SOLENOID
 9 BLK(W3400) RR SOLENOID
 10 BLK(W2400) RF SOLENOID
 11 N/C
 12 BLK(W8600) PUMP RELAY CONTROL

BLACK (CN7)
 PIN
 1 N/C
 2 N/C
 3 N/C
 4 N/C
 5 N/C
 6 N/C
 7 BLK(W9000) PARK BRAKE
 8 N/C
 9 N/C
 10 N/C
 11 BLK(W7699) WARN/CHIME CONTROL
 12 N/C

GRAY
 PIN
 1 RED(W6100) BATT
 2 RED(W6100) BATT
 3 WHT(W6230) GROUND
 4 WHT(W6230) GROUND

BLACK (CN8)
 PIN
 1 N/C
 2 N/C
 3 RED(W6800) SW BATT
 4 WHT(W6230) GROUND
 5 CAN SHIELD
 6 RED(W6120) ACCESSORY
 7 GREEN
 8 YELLOW

GRAY (CN6)
 PIN
 1 N/C
 2 N/C
 3 BLK(W1000) LF WARN SW
 4 BLK(W2000) RF WARN SW
 5 N/C
 6 N/C
 7 N/C
 8 N/C
 9 BLK(W3000) RR WARN SW
 10 BLK(W4000) LR WARN SW
 11 N/C
 12 WHT(W6235) GROUND

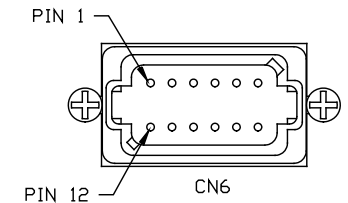
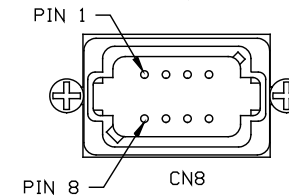
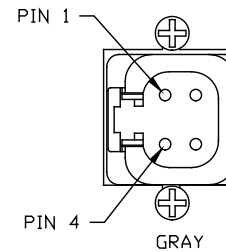
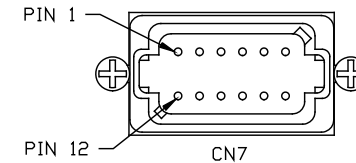
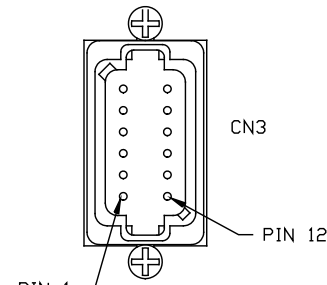

NOTE: WIRE NUMBERS ON THIS SHEET ARE REFERENCED TO HARNESS PLUGS.

NOTE: INSTALLATION MUST CONFORM TO GOOD SHOP PRACTICES, SAE STANDARDS, RVIA STANDARDS, AND OTHER APPLICABLE STANDARDS.

MP89474 C
 26NOV07

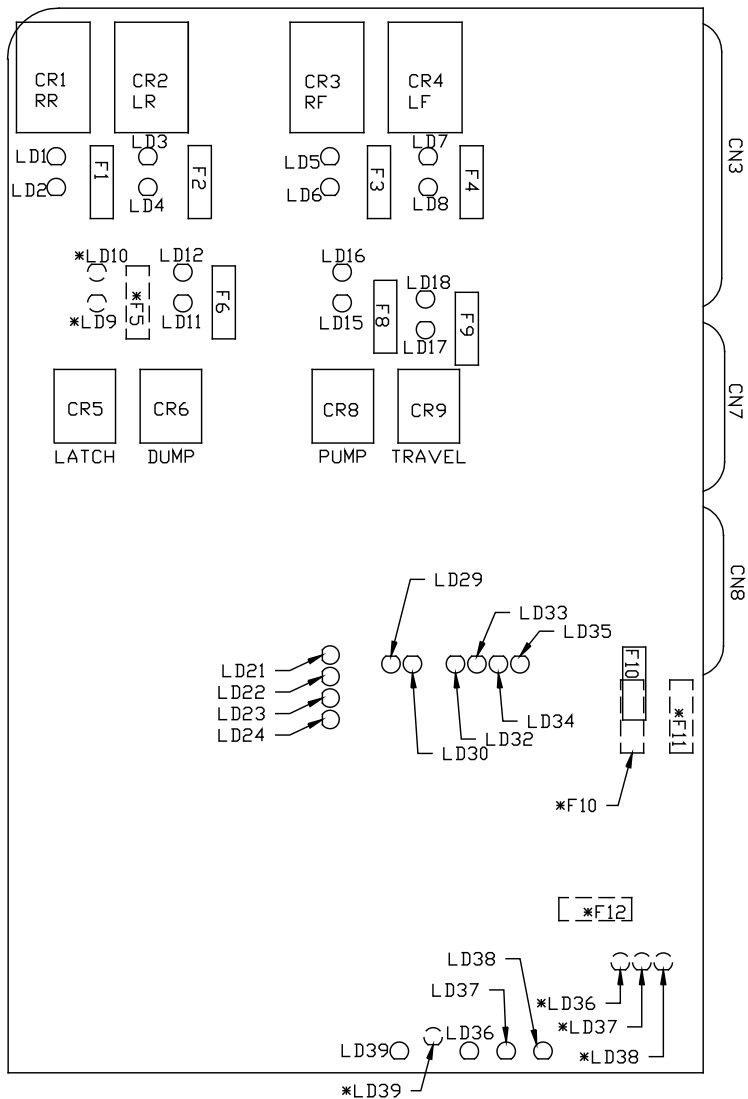

LED #	COLOR	DESCRIPTION
LED 1	YELLOW	RR COIL
LED 2	RED	RR CONTACT
LED 3	YELLOW	LR COIL
LED 4	RED	LR CONTACT
LED 5	YELLOW	RF COIL
LED 6	RED	RF CONTACT
LED 7	YELLOW	LF COIL
LED 8	RED	LF CONTACT
*LED 9	YELLOW	---
*LED 10	RED	---
LED 11	YELLOW	DUMP COIL
LED 12	RED	DUMP CONTACT
LED 15	YELLOW	PUMP COIL
LED 16	RED	PUMP CONTACT
LED 17	YELLOW	TRAVEL COIL
LED 18	RED	TRAVEL CONTACT
LED 21	YELLOW	LF WARN SW
LED 22	YELLOW	RF WARN SW
LED 23	YELLOW	RR WARN SW
LED 24	YELLOW	LR WARN SW
LED 29	RED	NOT USED
LED 30	YELLOW	NOT USED
LED 32	RED	MASTER WARNING CONTROL
LED 33	GREEN	50 LB PSW INPUT
LED 34	RED	JACK INTERRUPT
LED 35	RED	PARK BRAKE
LED 36	RED	BOARD ENABLED
LED 37	RED	ACCESSORY IN
LED 38	RED	ACCESSORY OUT
LED 39	RED	LINK LIGHT

FUSE	RATING	DESCRIPTION
F1	15 AMP	RR OUTPUT
F2	15 AMP	LR OUTPUT
F3	15 AMP	RF OUTPUT
F4	15 AMP	LF OUTPUT
*F5	NOT USED	---
F6	5 AMP	DUMP OUTPUT
F8	5 AMP	PUMP OUTPUT
F9	5 AMP	TRAVEL OUTPUT
F10	7.5 AMP	ACC INPUT
*F11	3 AMP	WARN LIGHT SUPPLY
*F12	10 AMP	ACC OUTPUT

NOTE: COMPONENTS MARKED WITH A "*" ARE LOCATED ON OLDER 325 BOARD ASSEMBLIES.

ON NEWER BOARD ASSEMBLIES, FUSES F5, F11 AND F12 HAVE BEEN REPLACED BY POLYFUSES. THESE POLYFUSES ARE NOT REPLACEABLE.

NOTE: INSTALLATION MUST CONFORM TO GOOD SHOP PRACTICES, SAE STANDARDS, RVIA STANDARDS, AND OTHER APPLICABLE STANDARDS.