

- PIN
1. YELLOW CAN HIGH
  2. GREEN CAN LOW
  3. CAN SHIELD
  4. WHT(W6230) GROUND
  5. RED(W6800) SW. BATTERY

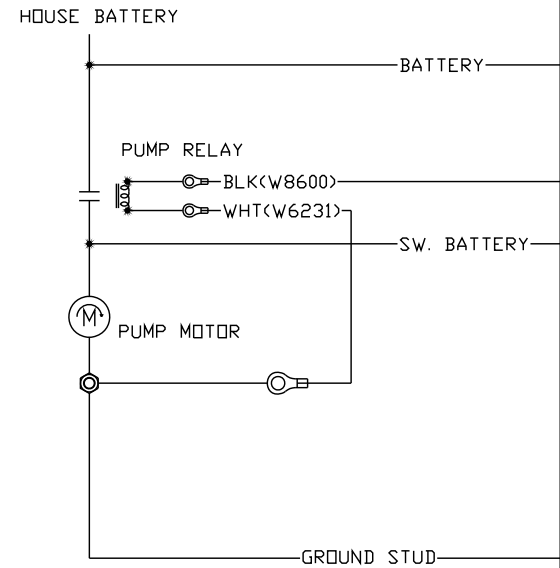
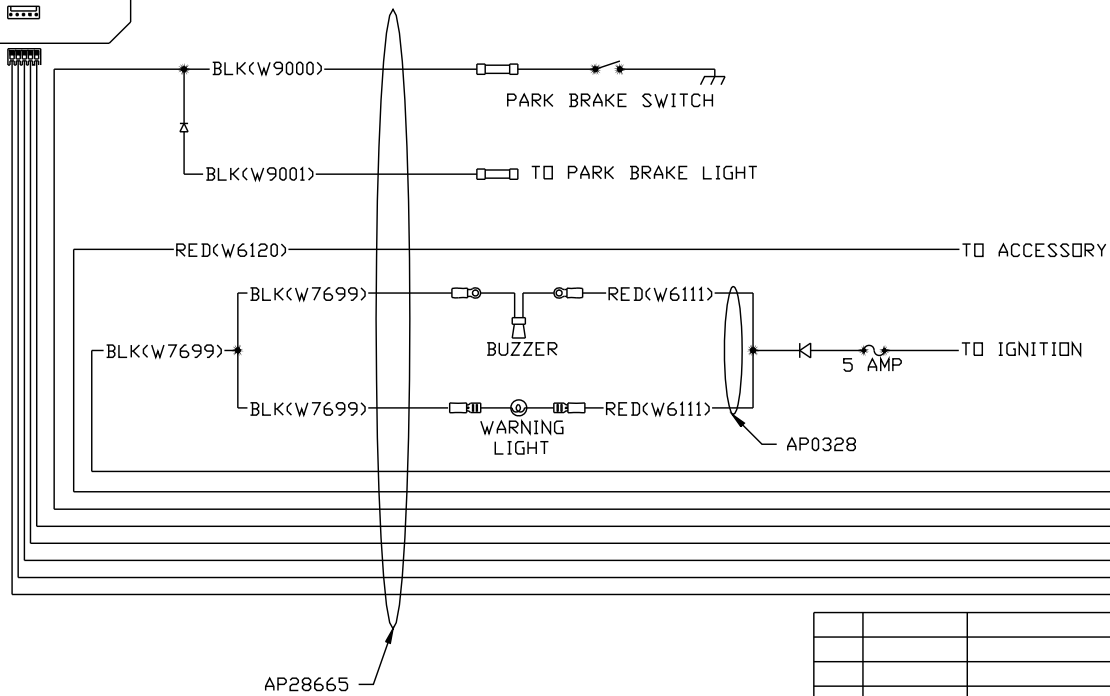

- BLK(W7699)
- RED(W6120)
- BLK(W9000)
- YELLOW
- GREEN
- SHIELD
- WHITE(W6230)
- RED(W6800)

NOTE: INSTALLATION MUST CONFORM TO GOOD SHOP PRACTICES, SAE STANDARDS, RVIA STANDARDS, AND OTHER APPLICABLE STANDARDS.

1	14NOV07	ADDED INSTALLATION NOTE
NO.	DATE	REVISION
THE INFORMATION DISCLOSED ON THIS DRAWING IS CONFIDENTIAL AND MUST NOT BE DISCLOSED OR USED IN ANY MANNER WHICH WILL BE DETRIMENTAL TO THE HWH CORPORATION		

HWH I-80 EXIT 267 SOUTH  
RT 1 MOSCOW, IOWA 52760

SCALE 1:3 DATE 31AUG05 DRAWN BY .

SYSTEM SCHEMATIC ELEC

DRAWING NUMBER  
MP89524 A/G

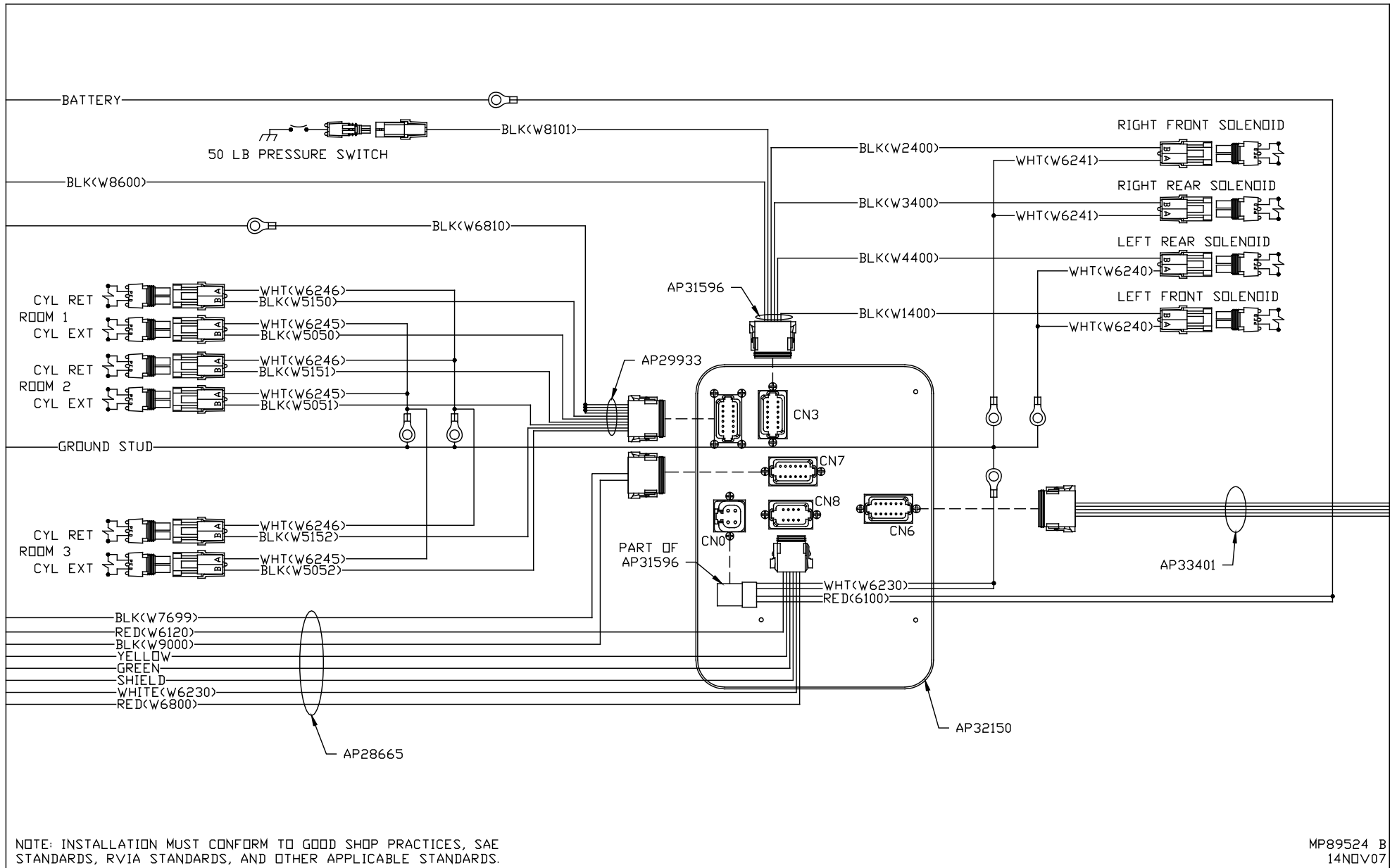

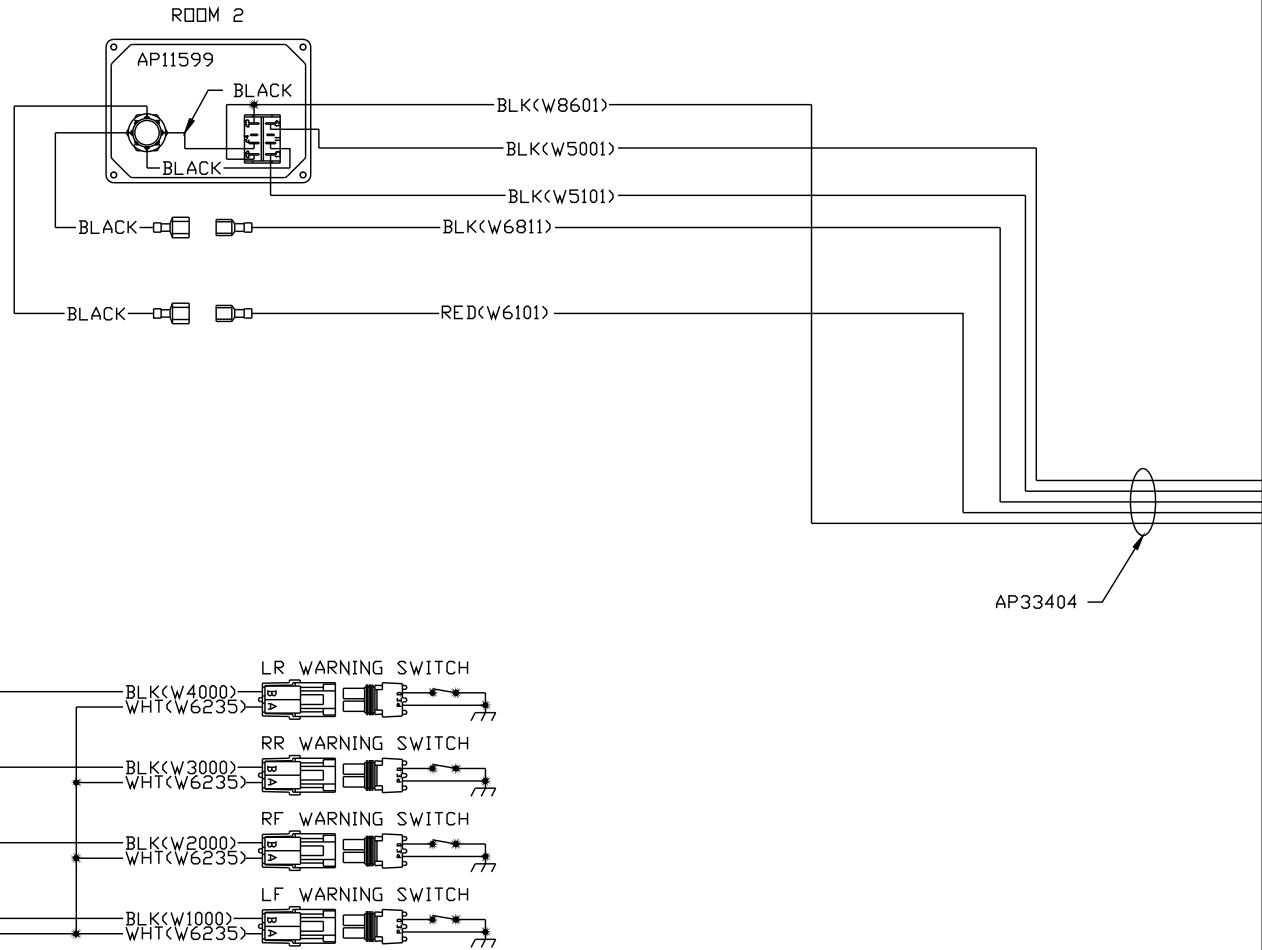

NOTE: INSTALLATION MUST CONFORM TO GOOD SHOP PRACTICES, SAE STANDARDS, RVIA STANDARDS, AND OTHER APPLICABLE STANDARDS.

BLACK 12 PIN

1. BLK(W6810) SWITCHED BATT. ROOM 2
2. BLK(W5000) EXTEND ROOM 2
3. BLK(W5100) RETRACT ROOM 2
4. BLK(W6811) SWITCHED BATT. ROOM 1
5. BLK(W5001) EXTEND ROOM 1
6. BLK(W5101) RETRACT ROOM 1
7. N/C
8. N/C (KEY PIN)
9. N/C
10. BLK(W8601) PUMP
11. RED(W6101) BATTERY
12. N/C (KEY PIN)

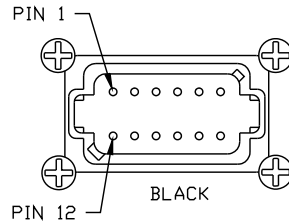

9 PIN

1. BLK(W5200) CLAMP RETRACT
2. RED(W6100) BATTERY
3. BLK(W7502) CLAMP RETRACT LIMIT SW.
4. BLK(W7503) CLAMP RETRACT LIMIT SW.
5. BLK(W5300) CLAMP EXTEND
6. BLK(W5300) CLAMP EXTEND
7. BLK(W7503) CLAMP RETRACT LIMIT SW.
8. BLK(W5200) CLAMP RETRACT
9. N/C

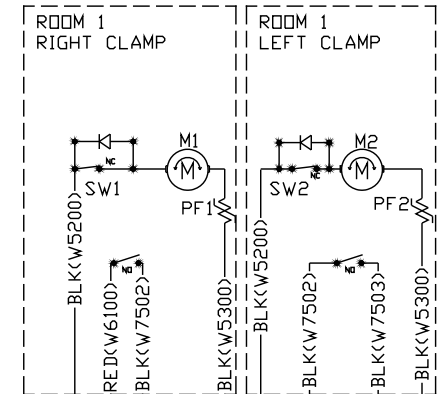

SEE MP89524 E FOR CONNECTIONS

LOCATING PIN

AP32150

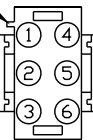
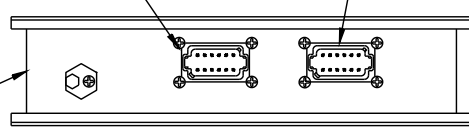

6 PIN

1. RED(W6100) BATTERY
2. BLK(W5300) CLAMP EXTEND
3. BLK(W5200) CLAMP RETRACT
4. BLK(W7503) CLAMP RETRACT LIMIT SW.
5. N/C
6. N/C

2 PIN

1. RED(W6100) BATTERY
2. BLK(W5200) CLAMP RET.

2 PIN

1. BLK(W7503) CLAMP RET. LIMIT SW.
2. BLK(W5300) CLAMP EXT.

6 PIN

1. BLK(W5200) CLAMP RET.
2. BLK(W7502) CLAMP RET. LIMIT SW.
3. BLK(W7503) CLAMP RET. LIMIT SW.
4. BLK(W5300) CLAMP EXT.
5. N/C
6. N/C

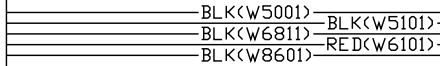

40 AMP BATTERY OEM PROVIDED

WHT(W6230) GROUND OEM PROVIDED

AP33404

LOCATING PIN

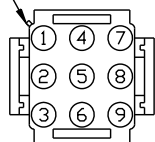

9 PIN

1. WHT(W6230) GROUND
2. WHT(W6230) GROUND
3. RED(W6100) BATTERY
4. RED(W6100) BATTERY
5. BLK(W5000) EXTEND ROOM 1
6. BLK(W5100) RETRACT ROOM 1
7. BLK(W8601) PUMP
8. BLK(W6810) SWITCHED BATTERY
9. BLK(W6810) SWITCHED BATTERY

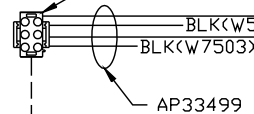

AP33496

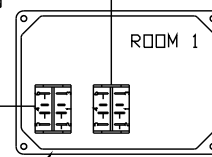

LOCATING PIN

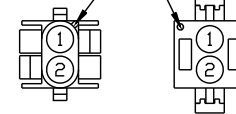

NOTE: INSTALLATION MUST CONFORM TO GOOD SHOP PRACTICES, SAE STANDARDS, RVIA STANDARDS, AND OTHER APPLICABLE STANDARDS.

BLACK 12 PIN

1. BLK(W6812) SWITCHED BATT. ROOM 3
2. BLK(W5002) EXTEND ROOM 3
3. BLK(W5102) RETRACT ROOM 3
4. N/C
5. N/C
6. N/C
7. N/C
8. N/C (KEY PIN)
9. N/C (KEY PIN)
10. BLK(W8601) PUMP
11. N/C
12. N/C

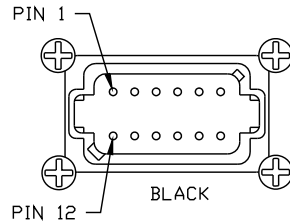

AP32150

SEE MP89524 D FOR CONNECTIONS

LOCATING PIN

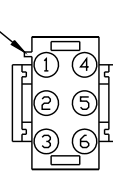

9 PIN

1. BLK(W5200) CLAMP RETRACT
2. RED(W6100) BATTERY
3. BLK(W7502) CLAMP RETRACT LIMIT SW.
4. BLK(W7503) CLAMP RETRACT LIMIT SW.
5. BLK(W5300) CLAMP EXTEND
6. BLK(W5300) CLAMP EXTEND
7. BLK(W7503) CLAMP RETRACT LIMIT SW.
8. BLK(W5200) CLAMP RETRACT
9. N/C

6 PIN

1. RED(W6100) BATTERY
2. BLK(W5300) CLAMP EXTEND
3. BLK(W5200) CLAMP RETRACT
4. BLK(W7503) CLAMP RETRACT LIMIT SW.
5. N/C
6. N/C

2 PIN

1. RED(W6100) BATTERY
2. BLK(W5200) CLAMP RET.

2 PIN

1. BLK(W7503) CLAMP RET. LIMIT SW.
2. BLK(W5300) CLAMP EXT.

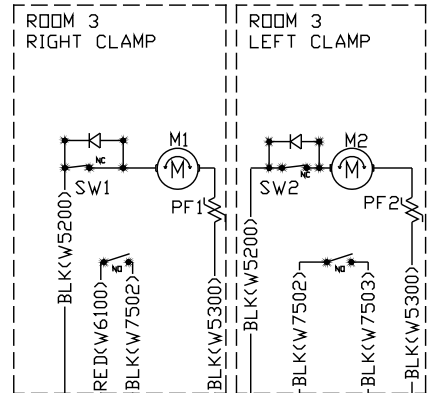

AP36384

9 PIN

1. WHT(W6230) GROUND
2. WHT(W6230) GROUND
3. RED(W6100) BATTERY
4. RED(W6100) BATTERY
5. BLK(W5002) EXTEND ROOM 3
6. BLK(W5102) RETRACT ROOM 3
7. BLK(W8601) PUMP RELAY
8. BLK(W6812) SWITCHED BATTERY
9. BLK(W6812) SWITCHED BATTERY

LOCATING PIN

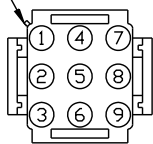

AP33496

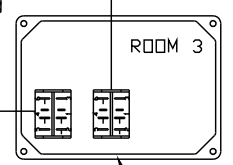

LOCATING PIN

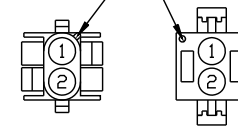

6 PIN

1. BLK(W5200) CLAMP RET.
2. BLK(W7502) CLAMP RET. LIMIT SW.
3. BLK(W7503) CLAMP RET. LIMIT SW.
4. BLK(W5300) CLAMP EXT.
5. N/C
6. N/C

NOTE: INSTALLATION MUST CONFORM TO GOOD SHOP PRACTICES, SAE STANDARDS, RVIA STANDARDS, AND OTHER APPLICABLE STANDARDS.

MP89524 E  
14NOV07

NOTE: WIRE NUMBERS ON THIS PAGE REFER TO HARNESS PLUGS.

GREEN 12 PIN

1. BLK(W5050) CYL EXT. ROOM 1
2. BLK(W5150) CYL RET. ROOM 1
3. BLK(W5151) CYL RET. ROOM 2
4. BLK(W5051) CYL EXT. ROOM 2
5. BLK(W5052) CYL EXT. ROOM 3
6. BLK(W5152) CYL RET. ROOM 3
7. N/C
8. N/C
9. BLK(W6810) SW. BATTERY
10. BLK(W6810) SW. BATTERY
11. BLK(W6810) SW. BATTERY
12. BLK(W6810) SW. BATTERY

CN3 (BROWN)

- PIN
- 1 N/C
  - 2 N/C
  - 3 BLK(W8101) 50 LB PRESS SW
  - 4 N/C
  - 5 BLK(W1400) LF SOLENOID
  - 6 N/C
  - 7 N/C
  - 8 BLK(W4400) LR SOLENOID
  - 9 BLK(W3400) RR SOLENOID
  - 10 BLK(W2400) RF SOLENOID
  - 11 N/C
  - 12 BLK(W8600) PUMP RELAY CONTROL

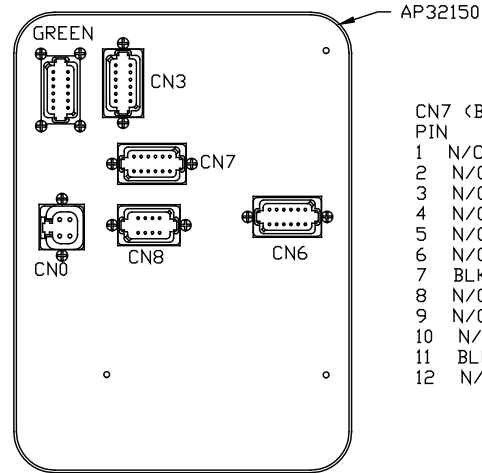
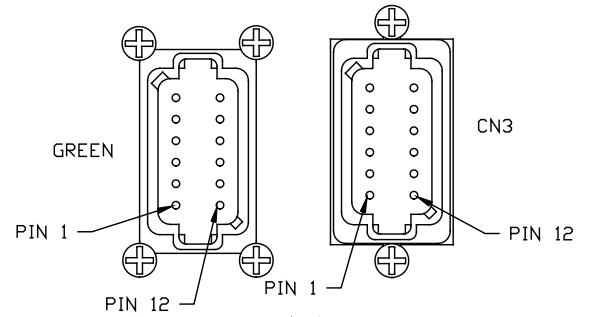

CN7 (BLACK)

- PIN
- 1 N/C
  - 2 N/C
  - 3 N/C
  - 4 N/C
  - 5 N/C
  - 6 N/C
  - 7 BLK(W9000) PARK BRAKE
  - 8 N/C
  - 9 N/C
  - 10 N/C
  - 11 BLK(W7699) WARN/BUZZER CONTROL
  - 12 N/C

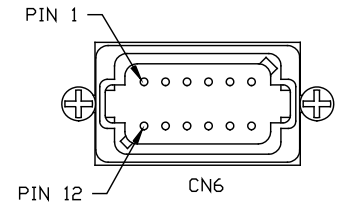
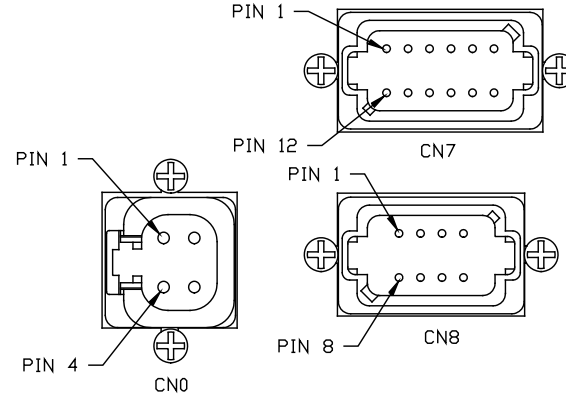

CN0 (GRAY)

- PIN
- 1 RED(W6100) BATT
  - 2 RED(W6100) BATT
  - 3 WHT(W6230) GROUND
  - 4 WHT(W6230) GROUND

CN8 (BLACK)

- PIN
- 1 N/C
  - 2 N/C
  - 3 RED(W6800) SW BATT
  - 4 WHT(W6230) GROUND
  - 5 CAN SHIELD
  - 6 RED(W6120) ACCESSORY
  - 7 GREEN
  - 8 YELLOW

CN6 (GRAY)

- PIN
- 1 N/C
  - 2 N/C
  - 3 BLK(W1000) LF WARN SW
  - 4 BLK(W2000) RF WARN SW
  - 5 N/C
  - 6 N/C
  - 7 N/C
  - 8 N/C
  - 9 BLK(W3000) RR WARN SW
  - 10 BLK(W4000) LR WARN SW
  - 11 N/C
  - 12 WHT(W6235) GROUND

NOTE: INSTALLATION MUST CONFORM TO GOOD SHOP PRACTICES, SAE STANDARDS, RVIA STANDARDS, AND OTHER APPLICABLE STANDARDS.

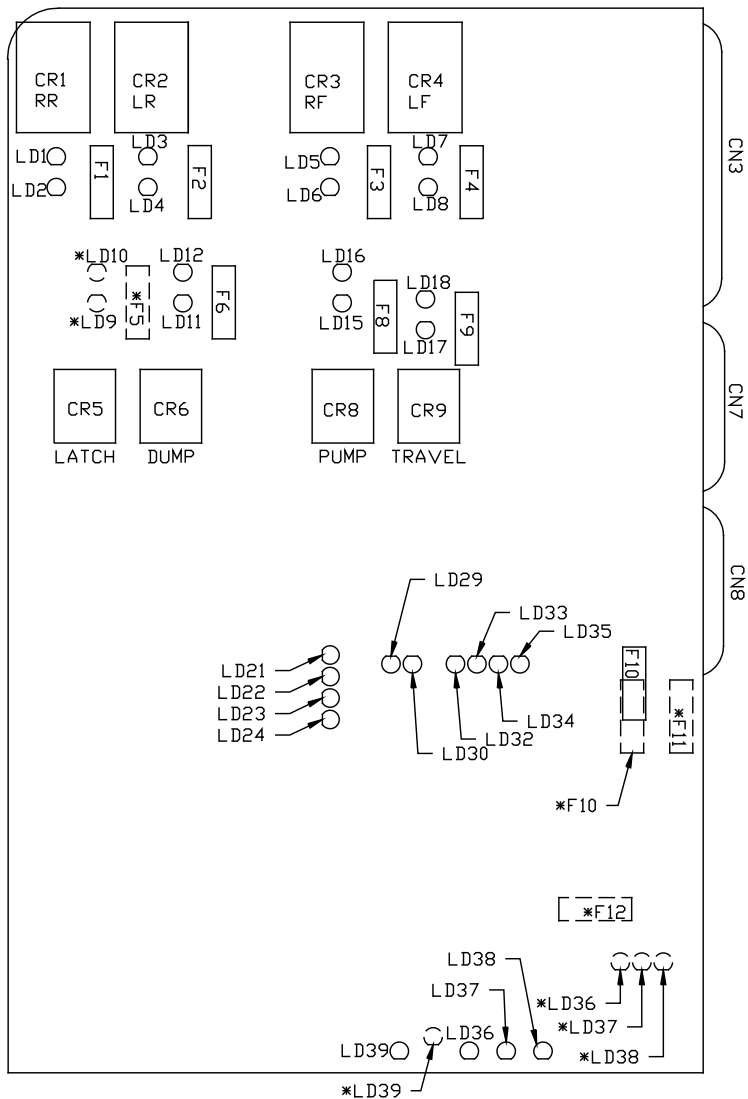

LED #	COLOR	DESCRIPTION
LED 1	YELLOW	RR COIL
LED 2	RED	RR CONTACT
LED 3	YELLOW	LR COIL
LED 4	RED	LR CONTACT
LED 5	YELLOW	RF COIL
LED 6	RED	RF CONTACT
LED 7	YELLOW	LF COIL
LED 8	RED	LF CONTACT
*LED 9	YELLOW	---
*LED 10	RED	---
LED 11	YELLOW	DUMP COIL
LED 12	RED	DUMP CONTACT
LED 15	YELLOW	PUMP COIL
LED 16	RED	PUMP CONTACT
LED 17	YELLOW	TRAVEL COIL
LED 18	RED	TRAVEL CONTACT
LED 21	YELLOW	LF WARN SW
LED 22	YELLOW	RF WARN SW
LED 23	YELLOW	RR WARN SW
LED 24	YELLOW	LR WARN SW
LED 29	RED	NOT USED
LED 30	YELLOW	NOT USED
LED 32	RED	MASTER WARNING CONTROL
LED 33	GREEN	50 LB PSW INPUT
LED 34	RED	JACK INTERRUPT
LED 35	RED	PARK BRAKE
LED 36	RED	BOARD ENABLED
LED 37	RED	ACCESSORY IN
LED 38	RED	ACCESSORY OUT
LED 39	RED	LINK LIGHT

FUSE	RATING	DESCRIPTION
F1	15 AMP	RR OUTPUT
F2	15 AMP	LR OUTPUT
F3	15 AMP	RF OUTPUT
F4	15 AMP	LF OUTPUT
*F5	NOT USED	---
F6	5 AMP	DUMP OUTPUT
F8	5 AMP	PUMP OUTPUT
F9	5 AMP	TRAVEL OUTPUT
F10	7.5 AMP	ACC INPUT
*F11	3 AMP	WARN LIGHT SUPPLY
*F12	10 AMP	ACC OUTPUT

NOTE: COMPONENTS MARKED WITH A "\*" ARE LOCATED ON OLDER 325 BOARD ASSEMBLIES.

ON NEWER BOARD ASSEMBLIES, FUSES F5, F11 AND F12 HAVE BEEN REPLACED BY POLYFUSES. THESE POLYFUSES ARE NOT REPLACEABLE.

NOTE: INSTALLATION MUST CONFORM TO GOOD SHOP PRACTICES, SAE STANDARDS, RVIA STANDARDS, AND OTHER APPLICABLE STANDARDS.