

FRONT VIEW - AP47627

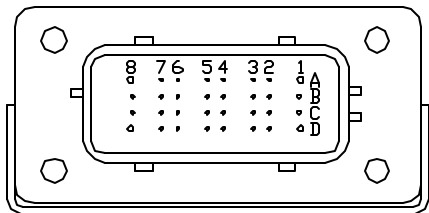

PIN

- A1. BLK(W8601) - PUMP REQUEST
- A2. YELLOW - CAN HIGH
- A3. N/C
- A4. N/C
- A5. BLK(W2000) - RIGHT FRONT JACK WARNING SWITCH
- A6. BLK(W2200) - RIGHT FRONT JACK PRESSURE SWITCH
- A7. BLK(W3200) - RIGHT REAR JACK PRESSURE SWITCH
- A8. BLK(W8101) - 50 LB. PRESSURE SWITCH
- B1. RED(W6800) - TOUCH PANEL POWER
- B2. GREEN - CAN LOW
- B3. WHT(W6230) - TOUCH PANEL GROUND
- B4. N/C
- B5. BLK(W3000) - RIGHT REAR JACK WARNING SWITCH
- B6. BLK(W4200) - LEFT REAR JACK PRESSURE SWITCH
- B7. N/C
- B8. BLK(W8100) - 3000 LB. PRESSURE SWITCH
- C1. RED(W6121) - LEVEL SENSOR POWER
- C2. CAN SHIELD
- C3. WHT(W6231) - LEVEL SENSOR GROUND
- C4. BLK(W0400) - REAR SENSE
- C5. BLK(W4000) - LEFT REAR JACK WARNING SWITCH
- C6. N/C
- C7. N/C
- C8. BLK(W0300) - RIGHT SIDE SENSE
- D1. RED(W6120) - ACCESSORY
- D2. WHT(W6235) - JACK WARNING SWITCH GROUND
- D3. N/C
- D4. BLK(W1000) - LEFT FRONT JACK WARNING SWITCH
- D5. BLK(W1200) - LEFT FRONT JACK PRESSURE SWITCH
- D6. BLK(W0100) - LEFT SIDE SENSE
- D7. BLK(W0200) - FRONT SENSE
- D8. BLK(W9000) - PARK BRAKE

NOTE: WIRE NUMBERS ON THIS SHEET ARE REFERENCED TO HARNESS PLUGS.

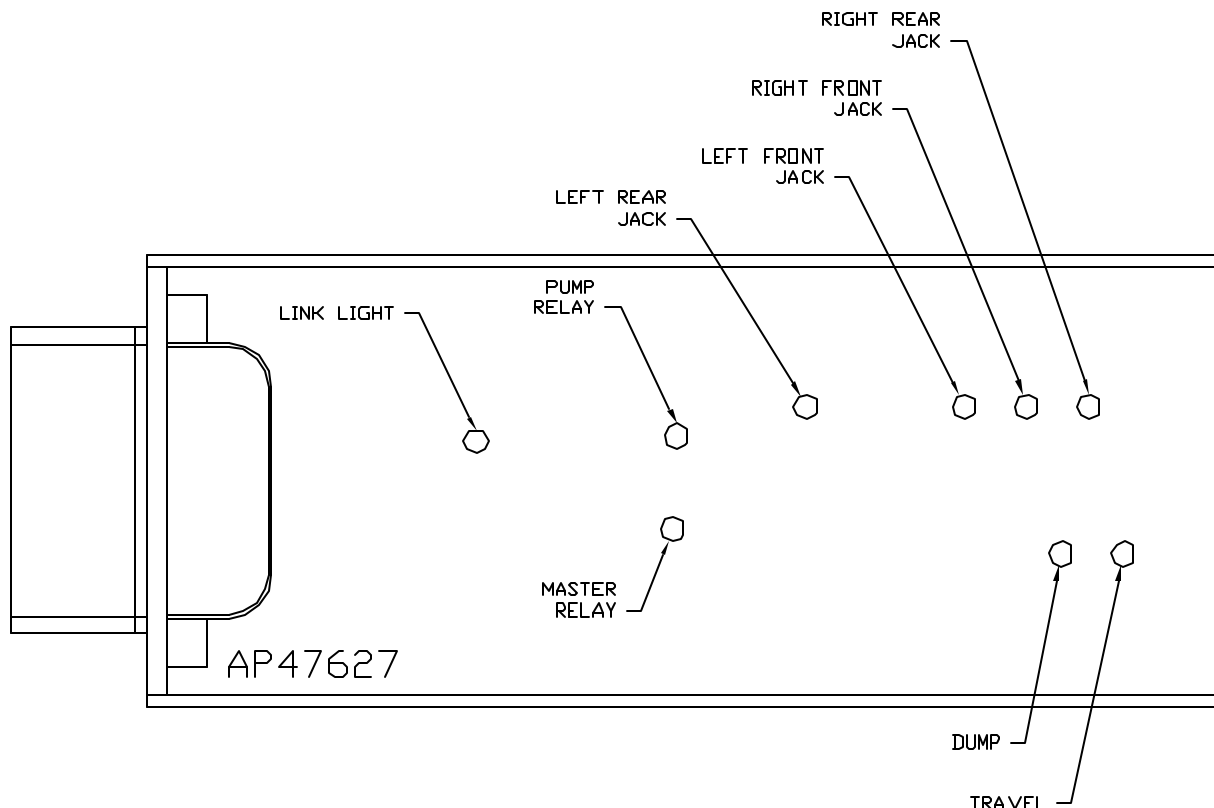

NOTE: INSTALLATION MUST CONFORM TO GOOD SHOP PRACTICES, SAE STANDARDS, RVIA STANDARDS, AND OTHER APPLICABLE STANDARDS.

			HWH		I-80 EXIT 267 SOUTH RT 1 MOSCOW, IOWA 52760	
3	17JAN12	UPDATED WIRE NUMBERS	SCALE 1:3	DATE 14JUN11	DRAWN BY .	
2	17OCT11	CORRECTED PART NO.	SYSTEM SCHEMATIC ELEC			
1	20JUL11	REVISED HARNESSSES				
NO.	DATE	REVISION				
THE INFORMATION DISCLOSED ON THIS DRAWING IS CONFIDENTIAL AND MUST NOT BE DISCLOSED OR USED IN ANY MANNER WHICH WILL BE DETRIMENTAL TO THE HWH CORPORATION			DRAWING NUMBER MP90634 A/E			

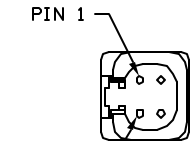

PIN 4

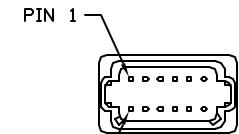

PIN 12

FRONT VIEW
AP33582
SPIDER INTERFACE BOX

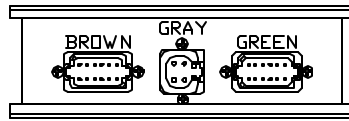

BROWN
PIN

- 1) BLK(W5050) CYL. 1 EXTEND
- 2) BLK(W5150) CYL. 1 RETRACT
- 3) BLK(W5051) CYL. 2 EXTEND
- 4) BLK(W5151) CYL. 2 RETRACT
- 5) BLK(W5052) CYL. 3 EXTEND
- 6) BLK(W5152) CYL. 3 RETRACT
- 7) N/C
- 8) N/C
- 9) BLK(W5053) CYL. 4 EXTEND
- 10) BLK(W5153) CYL. 4 RETRACT
- 11) BLK(W8601) PUMP
- 12) RED(W6100) BATT.

GRAY
PIN

1. BLK(W6810) SW. BATT
2. BLK(W6810) SW. BATT
3. WHT(W6230) GROUND
4. WHT(W6230) GROUND

GREEN
PIN

1. BLK(W7502) CYL. 1 RETRACT
2. BLK(W7505) CYL. 2 RETRACT
3. BLK(W7508) CYL. 3 RETRACT
4. BLK(W7511) CYL. 4 RETRACT
5. BLK(W7513) NOT USED
6. BLK(W7503) PUMP CONTROL
7. N/C (KEY PIN)
8. BLK(W7514) NOT USED
9. BLK(W7510) CYL. 4 EXTEND
10. BLK(W7507) CYL. 3 EXTEND
11. BLK(W7504) CYL. 2 EXTEND
12. BLK(W7501) CYL. 1 EXTEND

NOTE: DEUTSCH PIN NUMBERS TYPICAL UNLESS OTHERWISE NOTED

NOTE: WIRE NUMBERS ON THIS SHEET ARE REFERENCED TO HARNESS PLUGS.

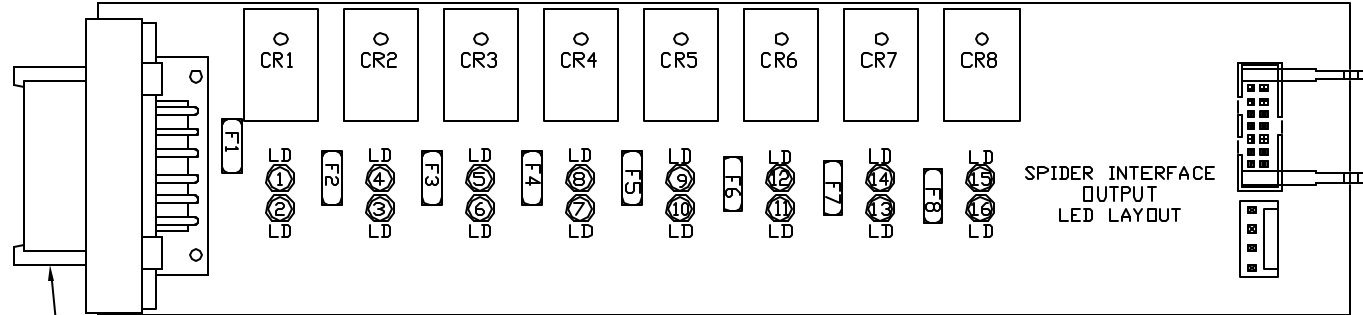

BROWN

GREEN

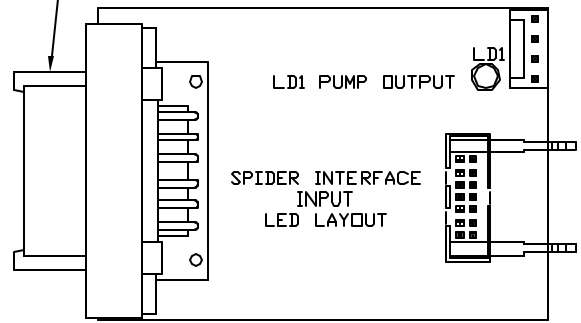

LED #	COLOR	INPUT J3	FUSE #	OUTPUT	RELAY #	DESCRIPTION
LED1	YELLOW	PIN 13	---	---	CR1	ROOM 1 EXTEND (COIL)
LED2	RED	---	FUSE 1 (15 AMP)	PIN 1	CR1	ROOM 1 EXTEND (CONTACT)
LED3	RED	---	FUSE 2 (15 AMP)	PIN 2	CR2	ROOM 1 RETRACT (CONTACT)
LED4	YELLOW	PIN 12	---	---	CR2	ROOM 1 RETRACT (COIL)
LED5	YELLOW	PIN 11	---	---	CR3	ROOM 2 EXTEND (COIL)
LED6	RED	---	FUSE 3 (15 AMP)	PIN 3	CR3	ROOM 2 EXTEND (CONTACT)
LED7	RED	---	FUSE 4 (15 AMP)	PIN 4	CR4	ROOM 2 RETRACT (CONTACT)
LED8	YELLOW	PIN 10	---	---	CR4	ROOM 2 RETRACT (COIL)
LED9	YELLOW	PIN 9	---	---	CR5	ROOM 3 EXTEND (COIL)
LED10	RED	---	FUSE 5 (15 AMP)	PIN 5	CR5	ROOM 3 EXTEND (CONTACT)
LED11	RED	---	FUSE 6 (15 AMP)	PIN 6	CR6	ROOM 3 RETRACT (CONTACT)
LED12	YELLOW	PIN 8	---	---	CR6	ROOM 3 RETRACT (COIL)
LED13	RED	---	FUSE 7 (15 AMP)	PIN 10	CR7	ROOM 4 RETRACT (CONTACT)
LED14	YELLOW	PIN 7	---	---	CR7	ROOM 4 RETRACT (COIL)
LED15	YELLOW	PIN 6	---	---	CR8	ROOM 4 EXTEND (COIL)
LED16	RED	---	FUSE 8 (15 AMP)	PIN 9	CR8	ROOM 4 EXTEND (CONTACT)

NOTE: INSTALLATION MUST CONFORM TO GOOD SHOP PRACTICES, SAE STANDARDS, RVIA STANDARDS, AND OTHER APPLICABLE STANDARDS.

NOTE: AP46382 TOUCH PANEL AND AP47709 CHIME KIT WHICH INCLUDES AP47711 AND AP47978 ARE ORDERED SEPARATELY FROM HWH CORP.

TO OEM PROVIDED PILOT DUMP CONNECTION

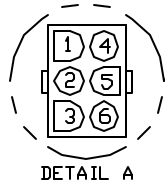
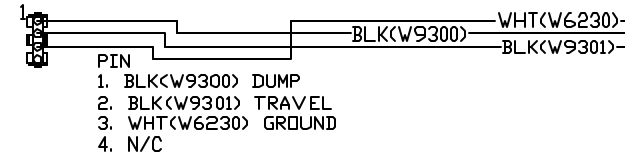

- PIN
 1. N/C
 2. N/C
 3. N/C
 4. N/C
 5. BLK(W7699) WARNING LED/CHIME CONTROL
 6. N/C

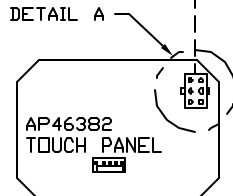

AP46382 TOUCH PANEL

- PIN
 1. YELLOW CAN HI
 2. GREEN CAN LOW
 3. CAN SHIELD
 4. WHT(W6230) GROUND
 5. RED(W6800) POWER

120 OHM TERMINATION RESISTOR

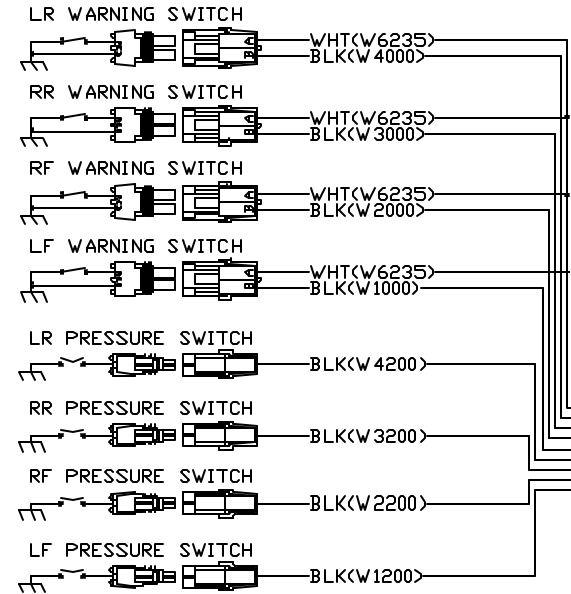
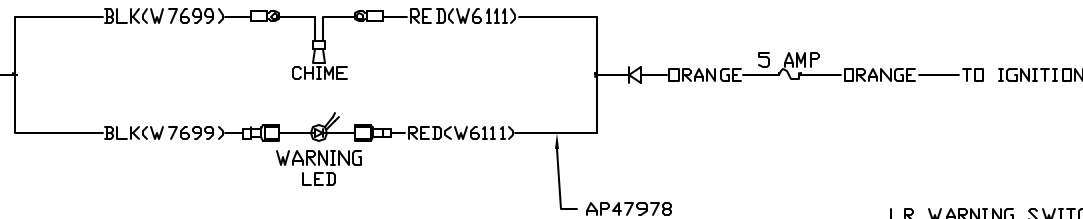

NOTE: INSTALLATION MUST CONFORM TO GOOD SHOP PRACTICES, SAE STANDARDS, RVIA STANDARDS, AND OTHER APPLICABLE STANDARDS.

MP90634 C
 20JUL11

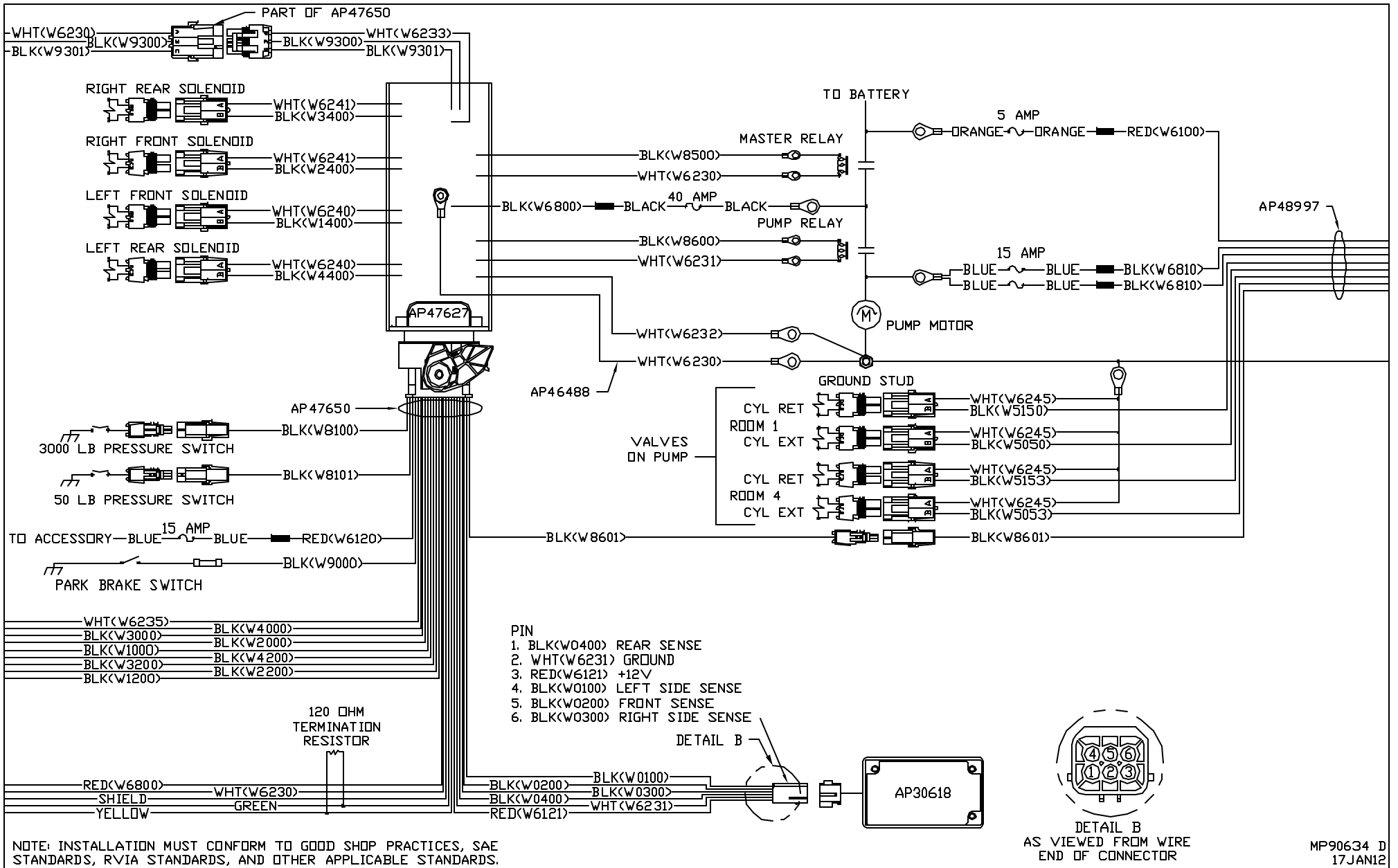

PIN

1. BLK(W6810) SW. BATT ROOM 1
2. BLK(W5150) CYL. RETRACT ROOM 1
3. BLK(W5050) CYL. EXTEND ROOM 1
4. BLK(W6810) SW. BATT ROOM 4
5. BLK(W5153) CYL. RETRACT ROOM 4
6. BLK(W5053) CYL. EXTEND ROOM 4
7. N/C
8. N/C
9. N/C (KEY PIN)
10. BLK(W8601) PUMP REQUEST
11. RED(W6100) BATTERY
12. N/C

PIN

1. BLK(W6810) SW. BATT ROOM 1
2. BLK(W5150) CYL. RETRACT ROOM 1
3. BLK(W5050) CYL. EXTEND ROOM 1
4. BLK(W6810) SW. BATT ROOM 4
5. BLK(W5153) CYL. RETRACT ROOM 4
6. BLK(W5053) CYL. EXTEND ROOM 4
7. N/C
8. N/C (KEY PIN)
9. N/C
10. BLK(W8601) PUMP REQUEST
11. RED(W6100) BATTERY
12. N/C (KEY PIN)

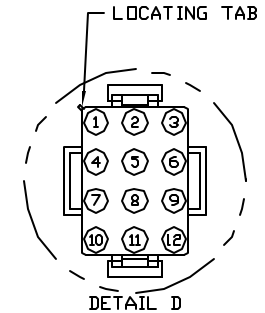
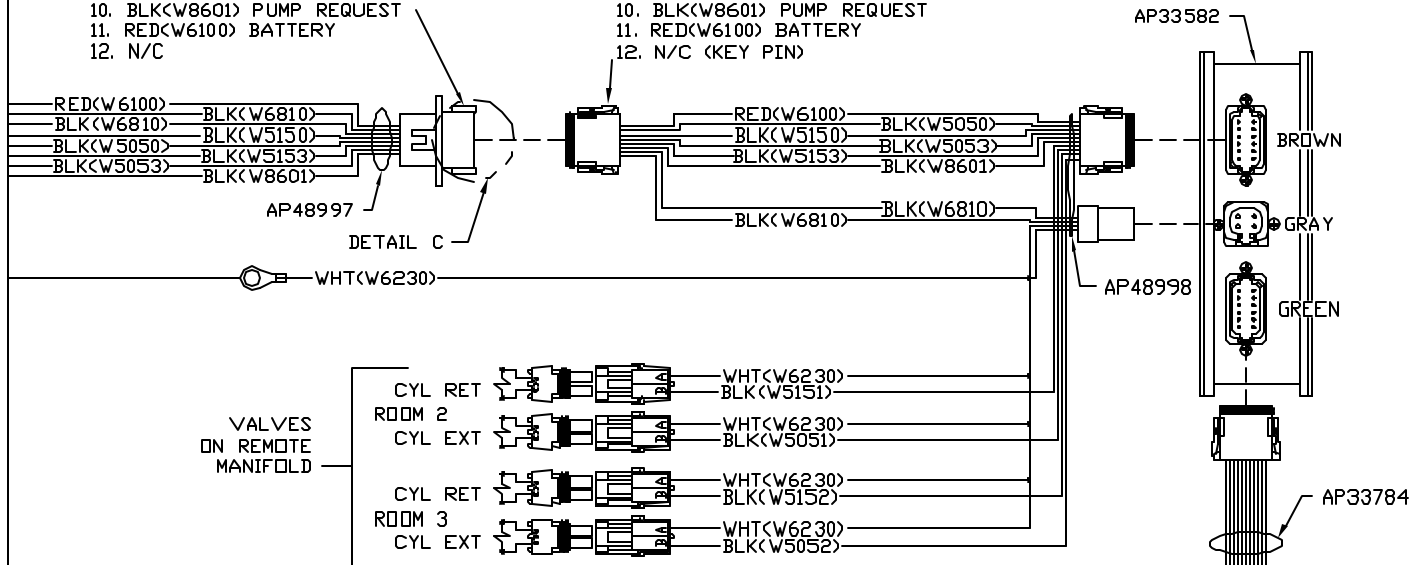
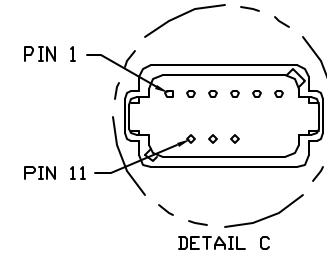

PIN

- 1) BLK(W7501) CYL. 1 EXTEND
- 2) BLK(W7502) CYL. 1 RETRACT
- 3) BLK(W7504) CYL. 2 EXTEND
- 4) BLK(W7505) CYL. 2 RETRACT
- 5) BLK(W7507) CYL. 3 EXTEND
- 6) BLK(W7508) CYL. 3 RETRACT
- 7) BLK(W7510) CYL. 4 EXTEND
- 8) BLK(W7511) CYL. 4 RETRACT
- 9) BLK(W7513) NOT USED
- 10) BLK(W7514) NOT USED
- 11) BLK(W7503) PUMP CONTROL
- 12) BLK(W7503) PUMP CONTROL

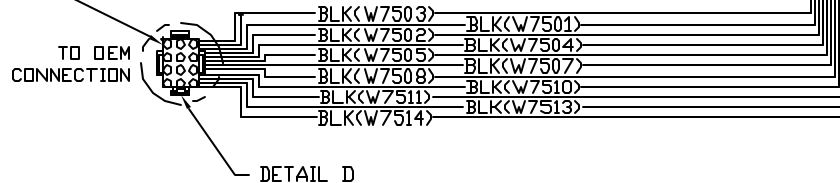

NOTE: ROOM EXTEND AND RETRACT LOGIC IS CONTROLLED BY SPIDER

NOTE: INSTALLATION MUST CONFORM TO GOOD SHOP PRACTICES, SAE STANDARDS, RVIA STANDARDS, AND OTHER APPLICABLE STANDARDS.