

FRONT VIEW - AP48445

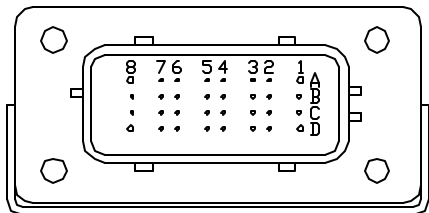

- PIN
- A1. RED(W6120) - ACCESSORY
  - A2. YELLOW - CAN HIGH
  - A3. N/C
  - A4. N/C
  - A5. N/C
  - A6. BLK(W2210) - RIGHT FRONT AIR PRESSURE SWITCH
  - A7. N/C
  - A8. N/C
  - B1. RED(W6122) - TOUCH PANEL POWER
  - B2. GREEN - CAN LOW
  - B3. N/C
  - B4. N/C
  - B5. N/C
  - B6. N/C
  - B7. N/C
  - B8. N/C
  - C1. RED(W6121) - LEVEL SENSOR POWER
  - C2. CAN SHIELD
  - C3. WHT(W6231) - LEVEL SENSOR GROUND
  - C4. BLK(W0400) - REAR SENSE
  - C5. N/C
  - C6. BLK(W9900) - SPEED SWITCH
  - C7. N/C
  - C8. BLK(W0300) - RIGHT SIDE SENSE
  - D1. RED(W6102) - SW. BATTERY
  - D2. WHT(W6232) - PRESSURE SWITCH GROUND
  - D3. WHT(W6230) - SYSTEM GROUND
  - D4. N/C
  - D5. BLK(W1210) - LEFT FRONT AIR PRESSURE SWITCH
  - D6. BLK(W0100) - LEFT SIDE SENSE
  - D7. BLK(W0200) - FRONT SENSE
  - D8. BLK(W9000) - PARK BRAKE

NOTE: WIRE NUMBERS ON THIS SHEET ARE REFERENCED TO HARNESS PLUGS.

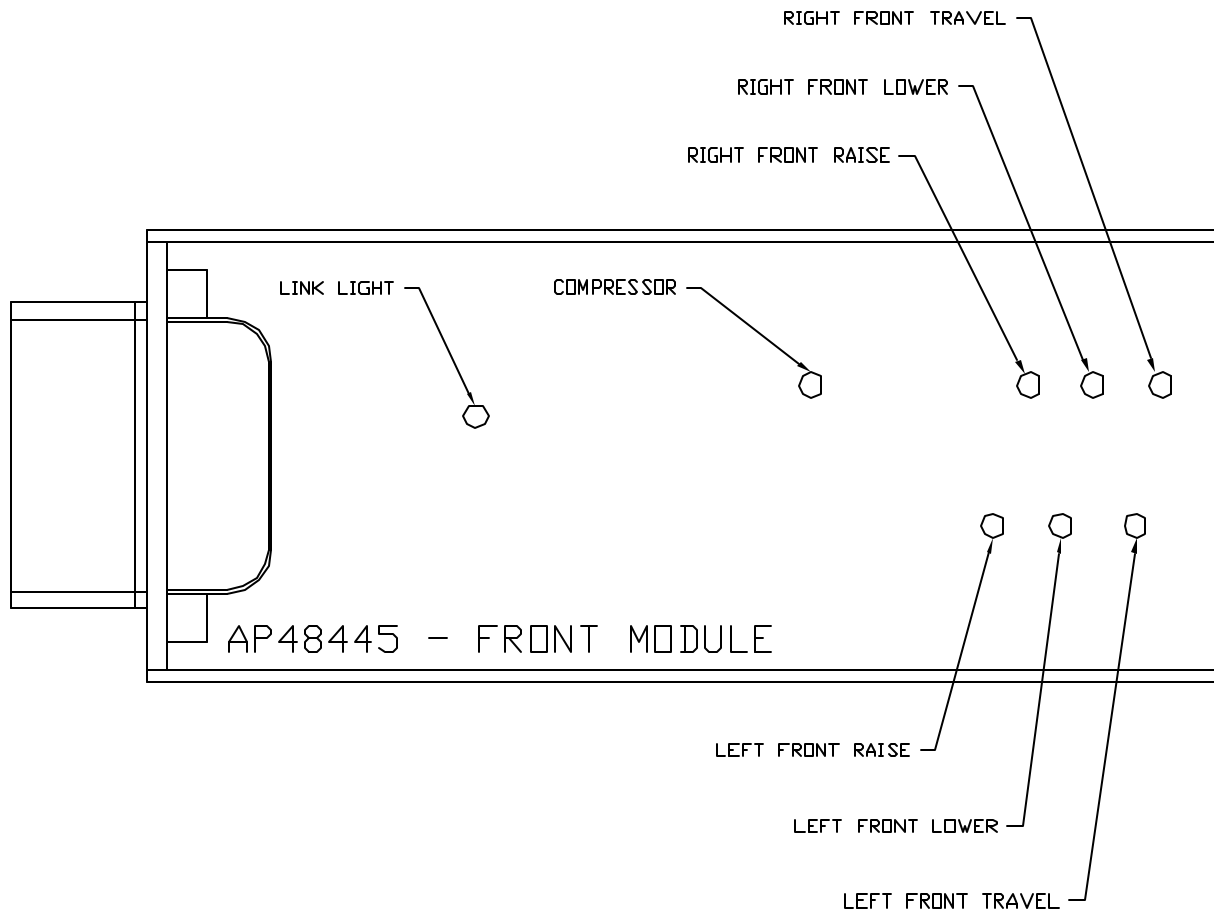

		<b>HWH</b>		I-80 EXIT 267 SOUTH RT 1 MOSCOW, IOWA 52760	
		SCALE 1:3	DATE 01JUL11	DRAWN BY .	
1	18JUL11	UPDATED WIRING			
NO.	DATE	REVISION			
<b>SYSTEM SCHEMATIC ELEC</b>					
THE INFORMATION DISCLOSED ON THIS DRAWING IS CONFIDENTIAL AND MUST NOT BE DISCLOSED OR USED IN ANY MANNER WHICH WILL BE DETRIMENTAL TO THE HWH CORPORATION				DRAWING NUMBER MP90647 A/F	

NOTE: INSTALLATION MUST CONFORM TO GOOD SHOP PRACTICES, SAE STANDARDS, RVIA STANDARDS, AND OTHER APPLICABLE STANDARDS.

FRONT VIEW - AP48446

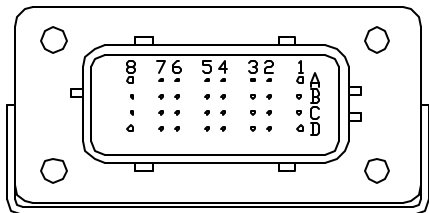

- PIN
- A1. N/C
  - A2. YELLOW - CAN HIGH
  - A3. N/C
  - A4. N/C
  - A5. N/C
  - A6. BLK(W3210) - RIGHT REAR AIR PRESSURE SWITCH
  - A7. N/C
  - A8. N/C
  - B1. N/C
  - B2. GREEN - CAN LOW
  - B3. N/C
  - B4. N/C
  - B5. N/C
  - B6. N/C
  - B7. N/C
  - B8. BLK(W3215) - SYSTEM AIR PRESSURE SWITCH
  - C1. N/C
  - C2. CAN SHIELD
  - C3. N/C
  - C4. N/C
  - C5. N/C
  - C6. N/C
  - C7. N/C
  - C8. N/C
  - D1. RED(W6122) - SW. BATTERY
  - D2. WHT(W6233) - PRESSURE SWITCH GROUND
  - D3. WHT(W6230) - SYSTEM GROUND
  - D4. N/C
  - D5. BLK(W4210) - LEFT REAR AIR PRESSURE SWITCH
  - D6. N/C
  - D7. N/C
  - D8. N/C

NOTE: WIRE NUMBERS ON THIS SHEET ARE REFERENCED TO HARNESS PLUGS.

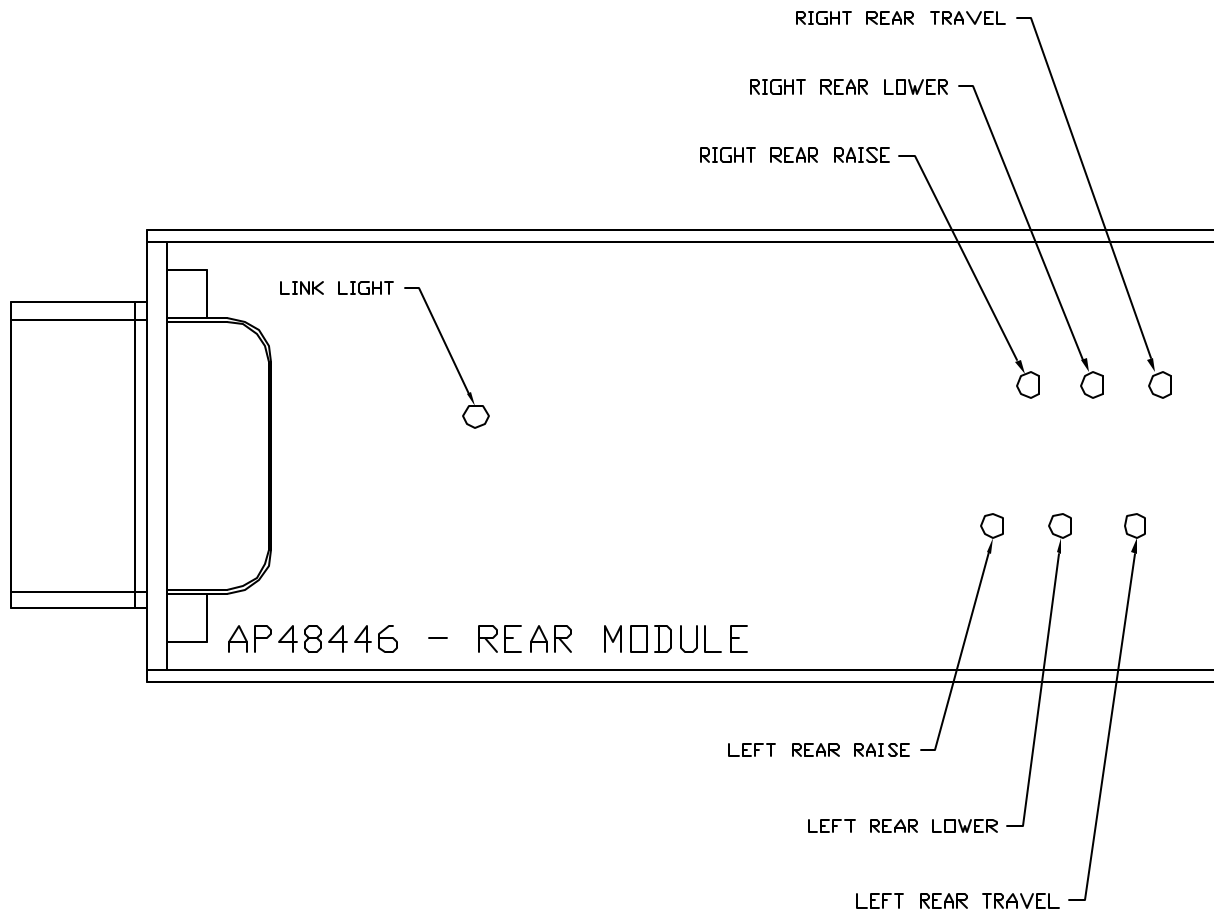

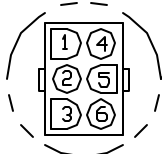

DETAIL 'A'

- PIN
1. N/C
  2. RED(W6110) WARNING LED SUPPLY
  3. N/C
  4. N/C
  5. BLK(W7699) WARNING LED CONTROL
  6. N/C

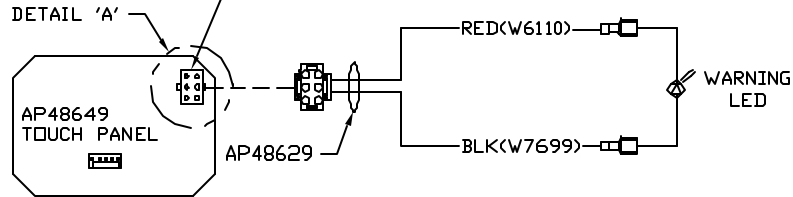

- PIN
- 1 YELLOW CAN HI
  - 2 GREEN CAN LOW
  - 3 CAN SHIELD
  - 4 WHT(W6230) GROUND
  - 5 RED(W6800) POWER

120 OHM  
TERMINATION  
RESISTOR

RED(W6122)  
SHIELD  
YELLOW  
WHT(W6230)  
GREEN

AP48928

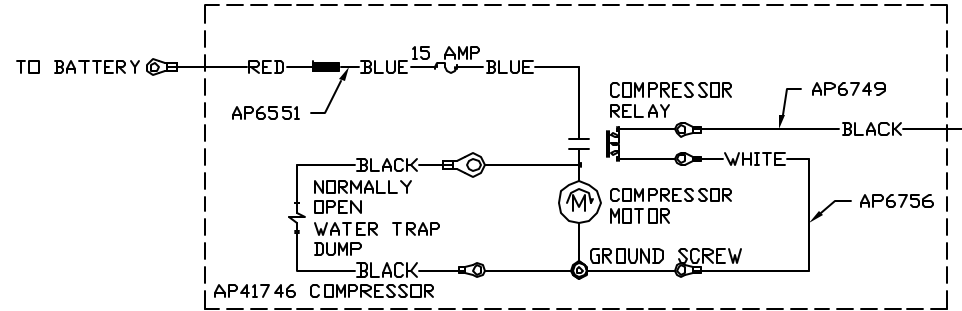

NOTE: INSTALLATION MUST CONFORM TO GOOD SHOP PRACTICES, SAE STANDARDS, RVIA STANDARDS, AND OTHER APPLICABLE STANDARDS.

MP90647 C  
01JUL11

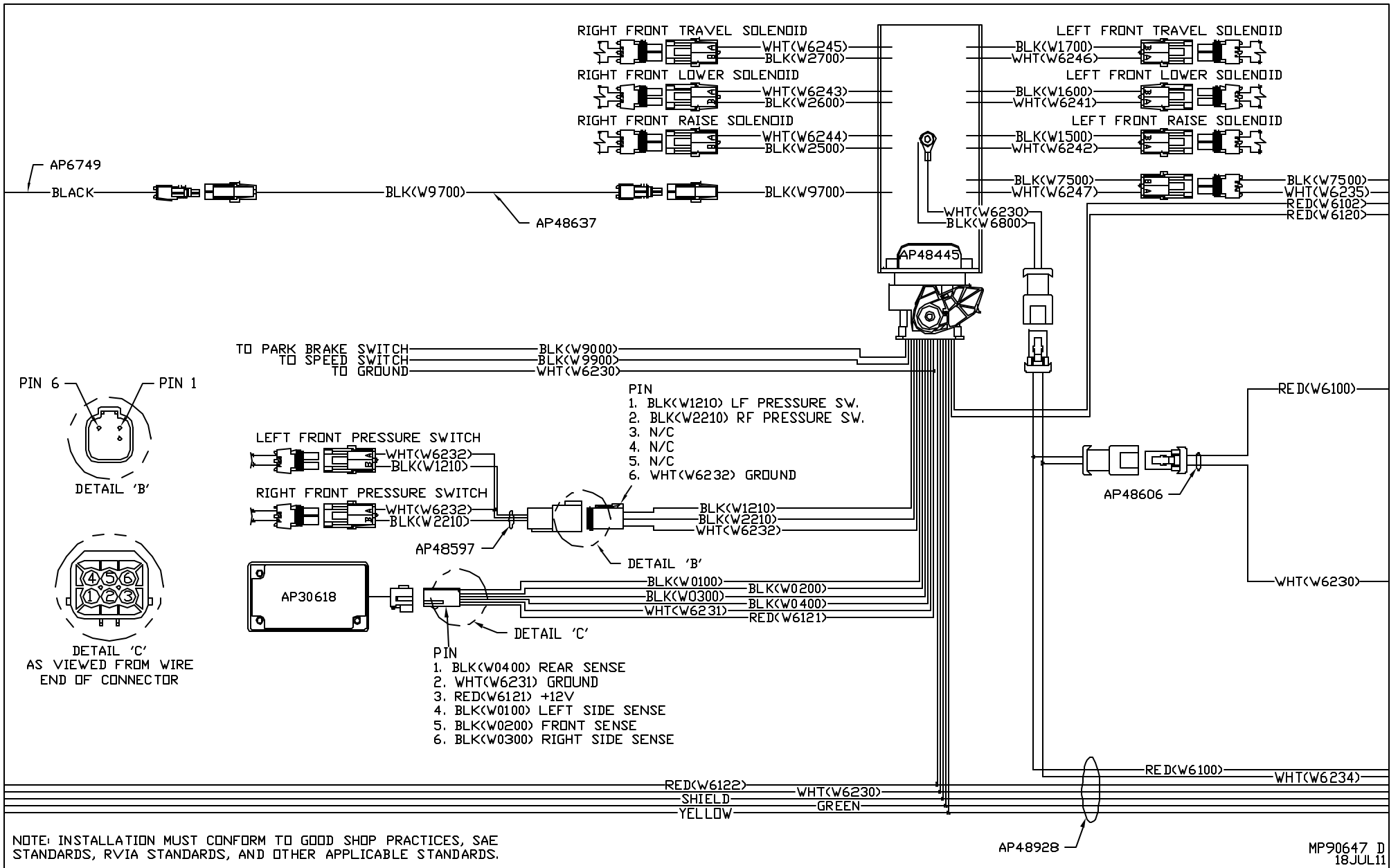

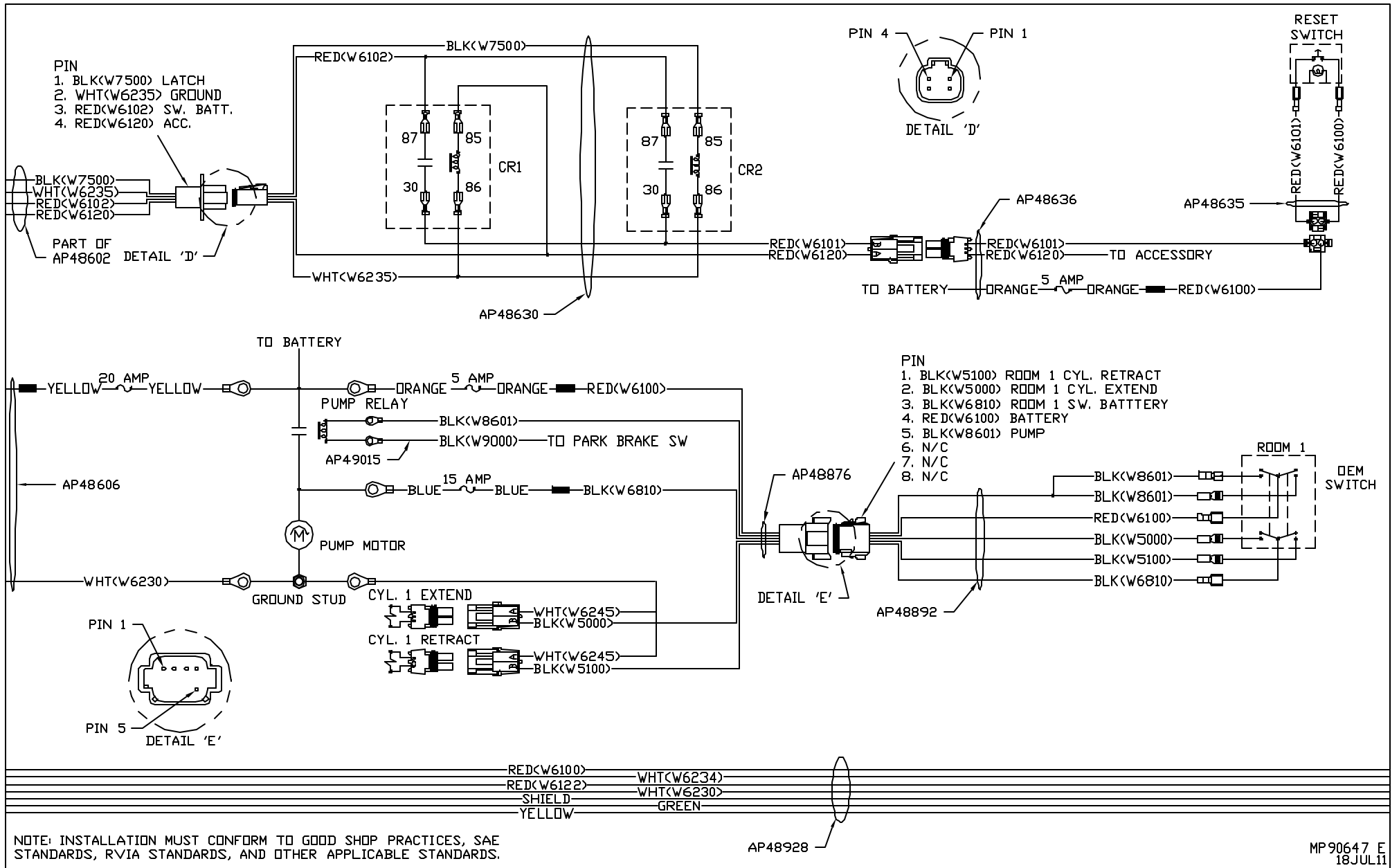

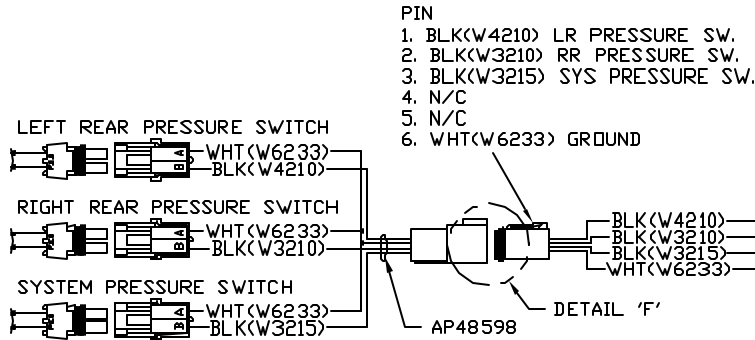
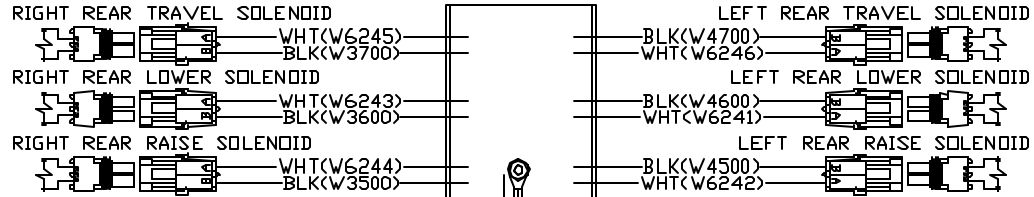
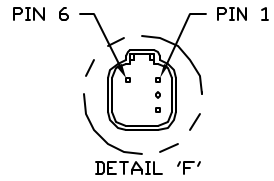

120 OHM  
TERMINATION  
RESISTOR

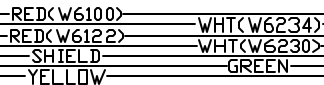

NOTE: INSTALLATION MUST CONFORM TO GOOD SHOP PRACTICES, SAE STANDARDS, RVIA STANDARDS, AND OTHER APPLICABLE STANDARDS.

AP48928

MP90647 F  
18JUL11