INSTRUCTION SHEET
BEARING PAD REPLACEMENT
UNDER-FLOOR-STRAIGHT OUT/SLANT OUT – “RAIL” STYLE MECHANISMS
SLOTTED FOR SLIDING COMPARTMENT SUPPORT BOLTS

This instruction sheet is for bearing pad kit RAP91975. The kit has the parts required to replace every bearing pad, including shims, for a single mechanism. This kit is used for several different mechanisms and may contain components not needed for your application.

The upper, lower and side bearing pads at the front of the mechanism can be replaced without removing the inner tube. The inner tube will have to be removed to replace the bearing pads on the rear of the inner tube.

It is easiest to replace the pads with the inner tube disconnected from the room. Extend the room fully. Block and support the room so it cannot drop or move with the operating mechanism(s) disconnected. If replacing the rear inner tube bearing pads, the rod will have to be disconnected from the mechanism and retracted. If the room has multiple mechanisms, the other mechanism(s) will also need to be disconnected from the room.

IMPORTANT: Always note the number of shims under each pad before removing pads.

Replacing the upper and lower bearing pads at the front of the mechanism. Remove the bearing pad retaining screw on the top of the mechanism. Pry the top outer bearing pad off. The outer bearing pad pins hold the inner bearing pad in place. Remove the top inner bearing pad. Lift the inner tube and replace the lower bearing pad(s) with appropriate shims. Lower the inner tube and slide the top inner bearing pad with appropriate shims back in place, lining up the holes. Re-install the top outer bearing pad making sure the pins are properly seated into the inner bearing pad. Install the bearing pad retaining screw and lock washer. Make the screw snug but do not over tighten.

FRONT VIEW OF MECHANISM
(FRONT MOUNTING BRACKET OMITTED FOR CLARITY)

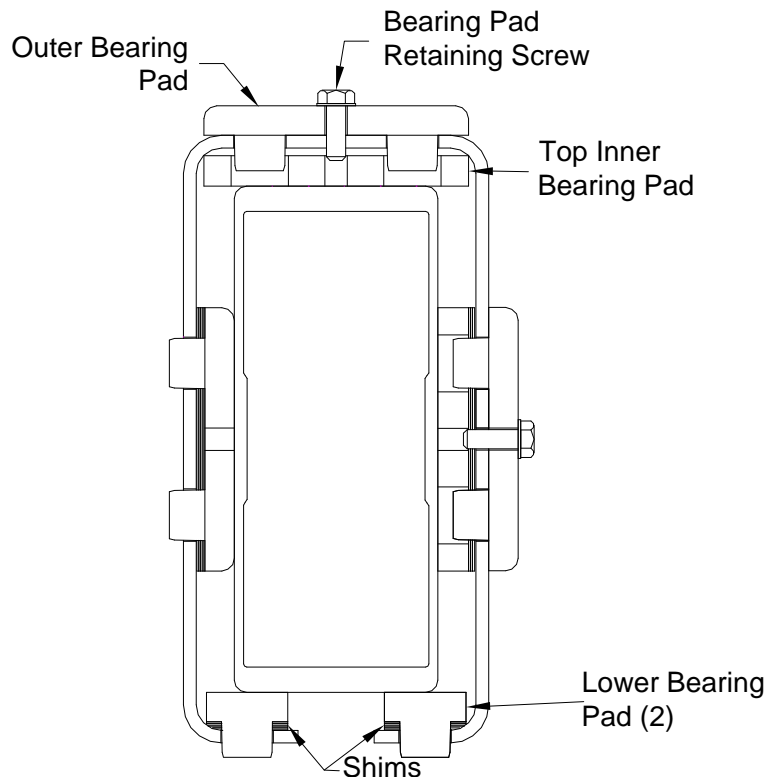

INSTRUCTION SHEET
BEARING PAD REPLACEMENT
UNDER-FLOOR – STRAIGHT OUT/SLANT OUT “RAIL” STYLE MECHANISMS
SLOTTED FOR SLIDING COMPARTMENT SUPPORT BOLTS

Replacing the side bearing pads at the front of the mechanism. Remove the bearing pad retaining screw on the side of the mechanism. Pry the side outer bearing pad off. The outer bearing pad pins hold the inner bearing pad in place. Remove the side inner bearing pad. Push the inner tube away from the other side bearing pad so the pad can be removed. Replace the side bearing pad with appropriate shims. Push the inner tube back against that bearing pad and slide the side inner bearing pad with appropriate shims back in place, lining up the holes. Re-install the side outer bearing pad making sure the pins are properly seated into the inner bearing pad. Install the bearing pad retaining screw and lock washer. Make the screw snug but do not over tighten. **For rooms with two mechanisms, one of the mechanisms may not have side bearing pads at the front of the mechanism. DO NOT add side bearing pads to this mechanism.**

FRONT VIEW OF MECHANISM
(FRONT MOUNTING BRACKET OMITTED FOR CLARITY)

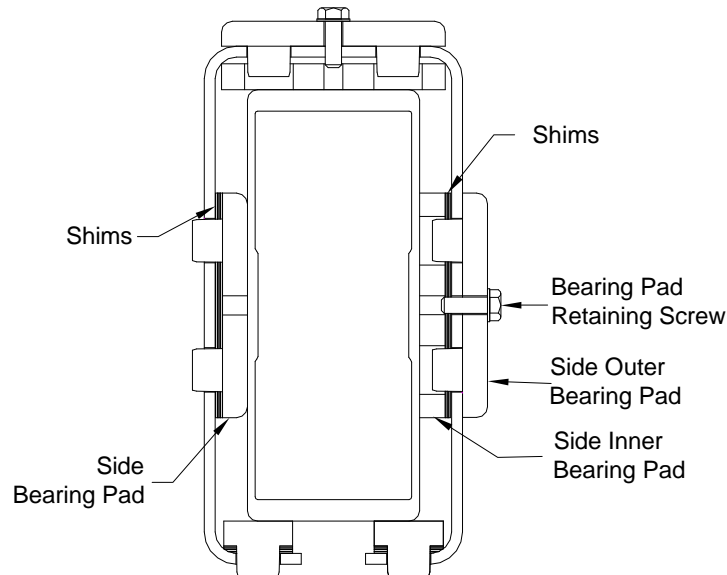

REAR VIEW OF MECHANISM
(REAR MOUNTING PLATE OMITTED FOR CLARITY)

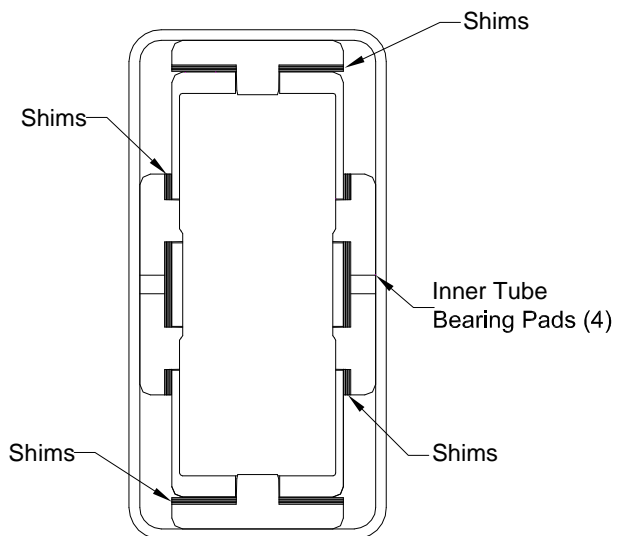

Replacing the inner tube bearing pads at the rear of the mechanism. Remove the upper, lower and side bearing pads at the front of the mechanism as explained in the above instructions. Remove the inner tube, replace inner tube bearing pads as necessary then slide the inner tube back in. Re-install the front lower, upper and side bearing pads and shims as explained in the above instructions.