

Mounting Bracket Kit: Kick-Down Jacks

Application: For mounting Kick-Down Jacks on FRONT OF FORD F53 chassis, 1997 and older with 16" TIRES and OSHKOSH chassis with front engine. Front bracket behind spring hanger.

- Mfr. #:** AP7485 Bracket Kit Ford/Oshkosh
Includes: 2 - AP8503 Bracket Ford Front
 2 - P12156 Heat Guard
 1 - AP9352 Hardware Kit
M.S.R.P.: See Item Price Listing

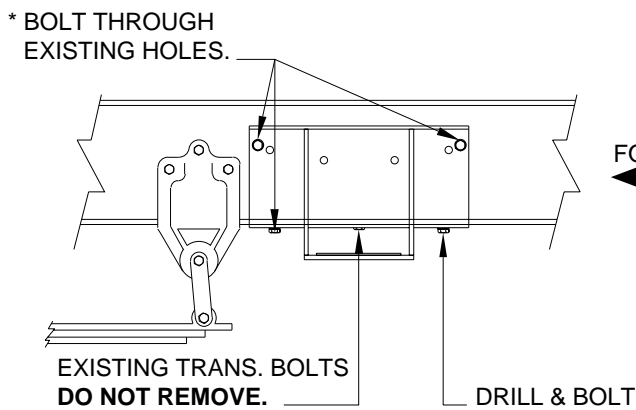
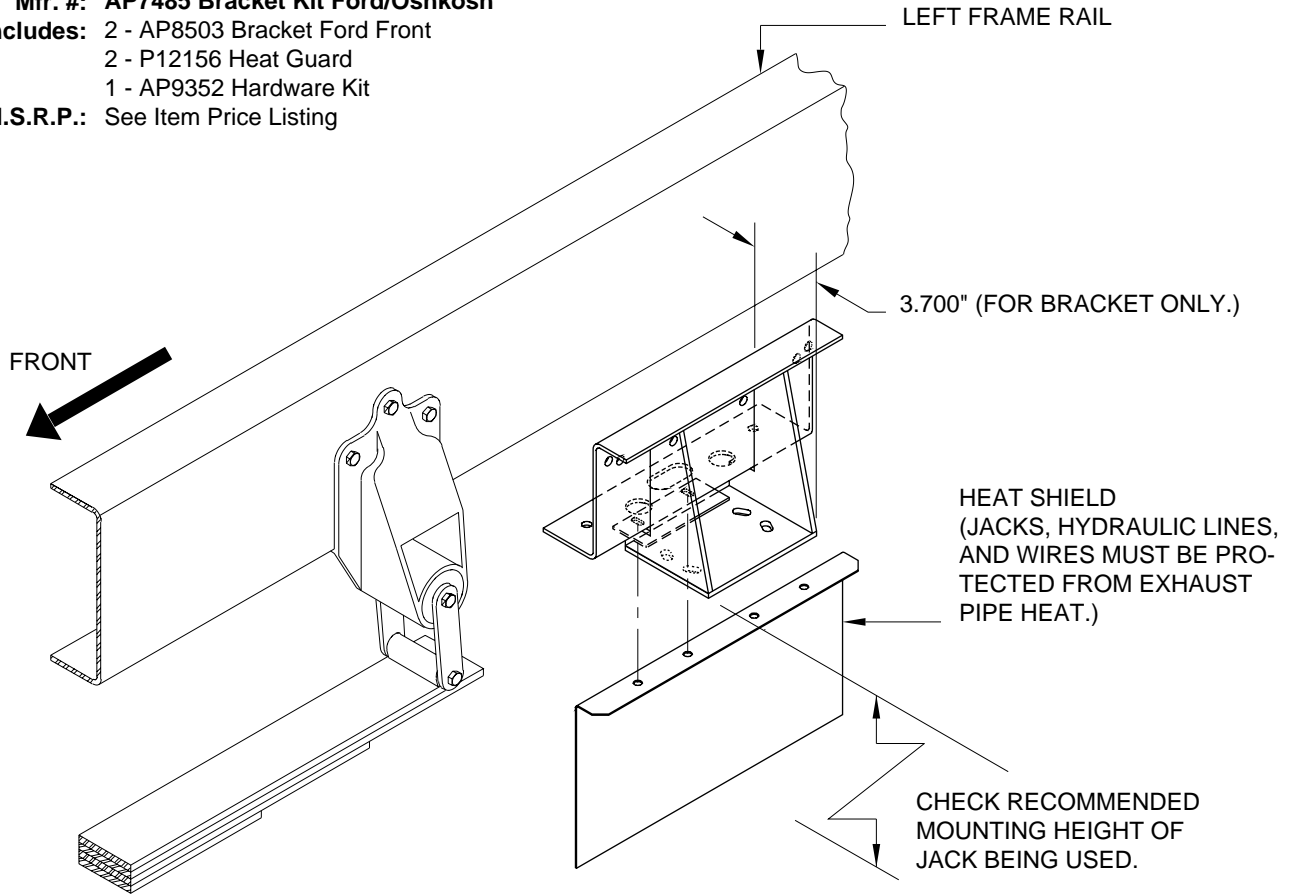

FORD

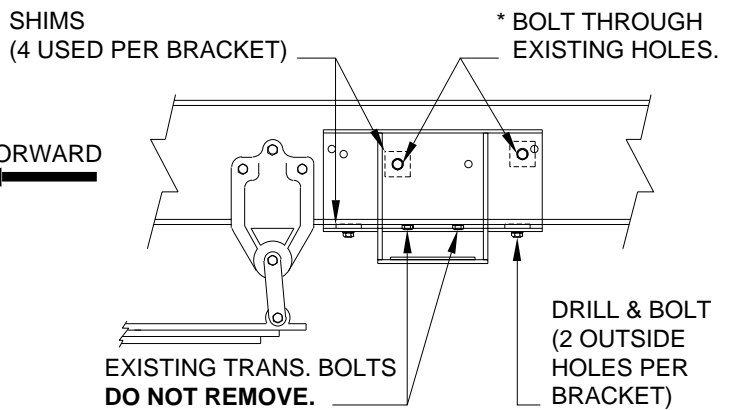

OSHKOSH

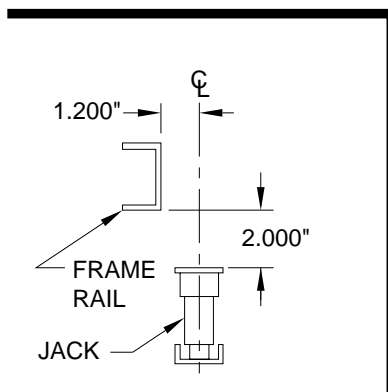

* MOUNTING HOLES MAY BE MISSING OR OBSTRUCTED ON SOME CHASSIS.

CAUTION: Follow CAUTIONS in Operator's and Installation Manuals concerning working under vehicles.

**MI25.1110
11JAN01**