

Mounting Bracket Kit: Kick-Down Jacks

Application: For mounting Kick-Down Jacks on the side of the frame rail, OSHKOSH/FORD and JOHN DEERE with Front Engine. Rear Bracket.

Mfr. #: AP7159 Bracket Kit Side of Frame, OSHKOSH/FORD and JOHN DEERE

Includes: 2 - AP7094 Bracket Rear
1 - AP6583 Hardware Kit

M.S.R.P.: See Item Price Listing

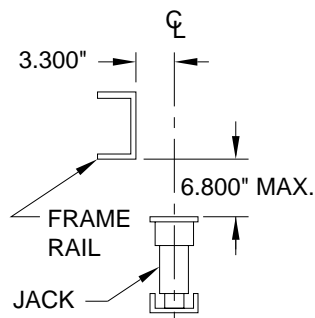
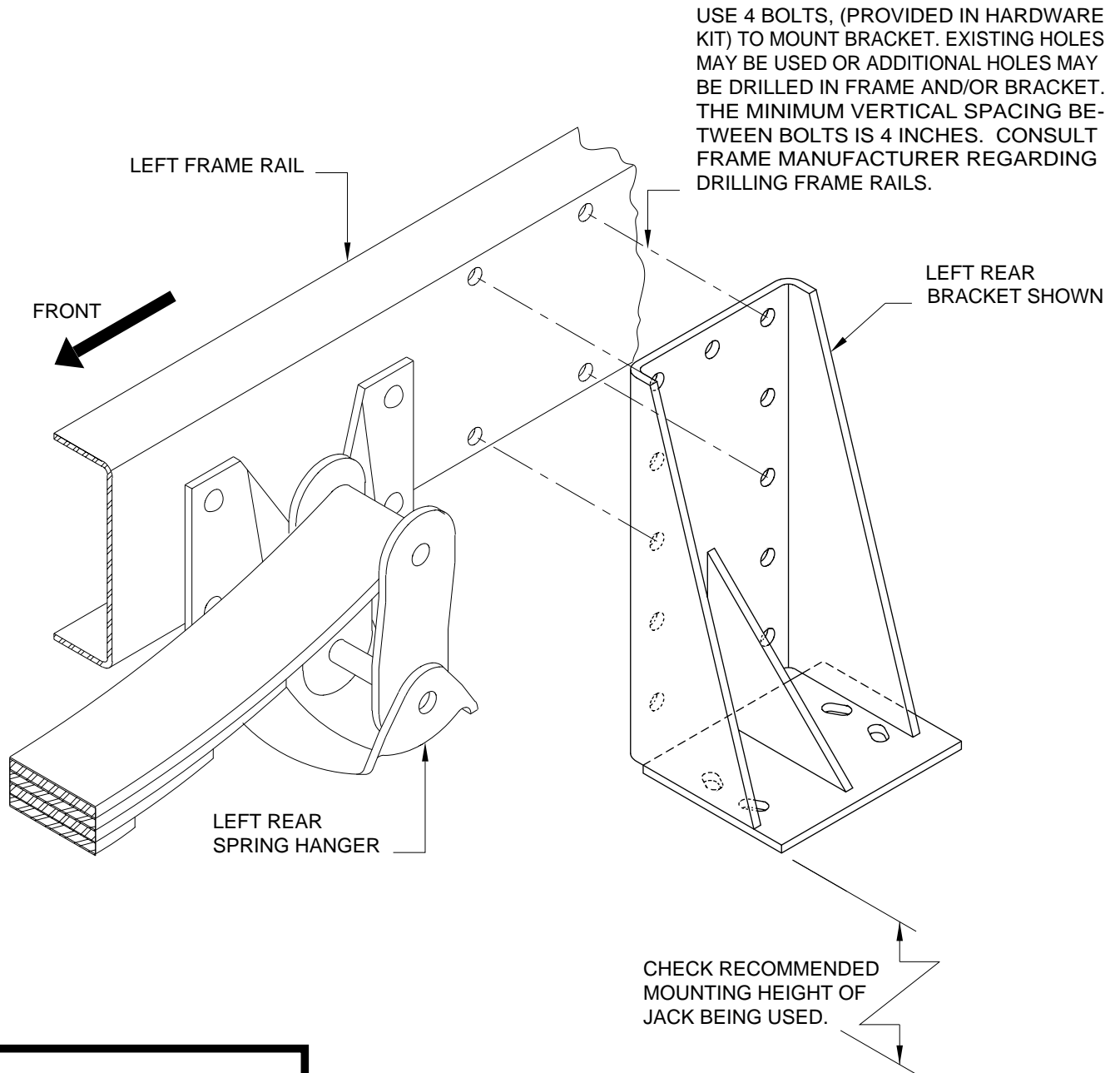

NOTE: IF JACK IS TOO CLOSE TO TAIL PIPE, HAVE COACH OWNER TAKE COACH TO A PROFESSIONAL MUFFLER SHOP.

NOTE: DO NOT USE THIS BRACKET UNLESS THERE IS A CHASSIS MFG'S CROSSMEMBER BY THE SPRING SHACKLE OR WITHIN 20" TO THE FRONT SHACKLE.

CAUTION: Follow CAUTIONS in Operator's and Installation Manuals concerning working under vehicles.

MI25.1180
16FEB01