

# Cross Tie and Jack Kit: Straight-Acting Jacks

**Application:** For mounting Straight-Acting Jacks on the rear of Ford F53: With Fleetwood Jack Mounting Bracket and Stock Rear Single Axle.

**Mfr. #: AP10480 Jack Kit**  
**Includes:** 2 - AP10466 Jack 2.0 x 13.0  
 2 - AP2043 Hardware Kit  
**M.S.R.P.:** See Item Price Listing

**Mfr. #: AP2226 Cross Tie Kit 41.00"**  
**Includes:** 1 - P2227 Chennel 41.00"  
 2 - P1915 Gusset  
 1 - AP2042 Hardware Kit  
**M.S.R.P.:** See Item Price Listing

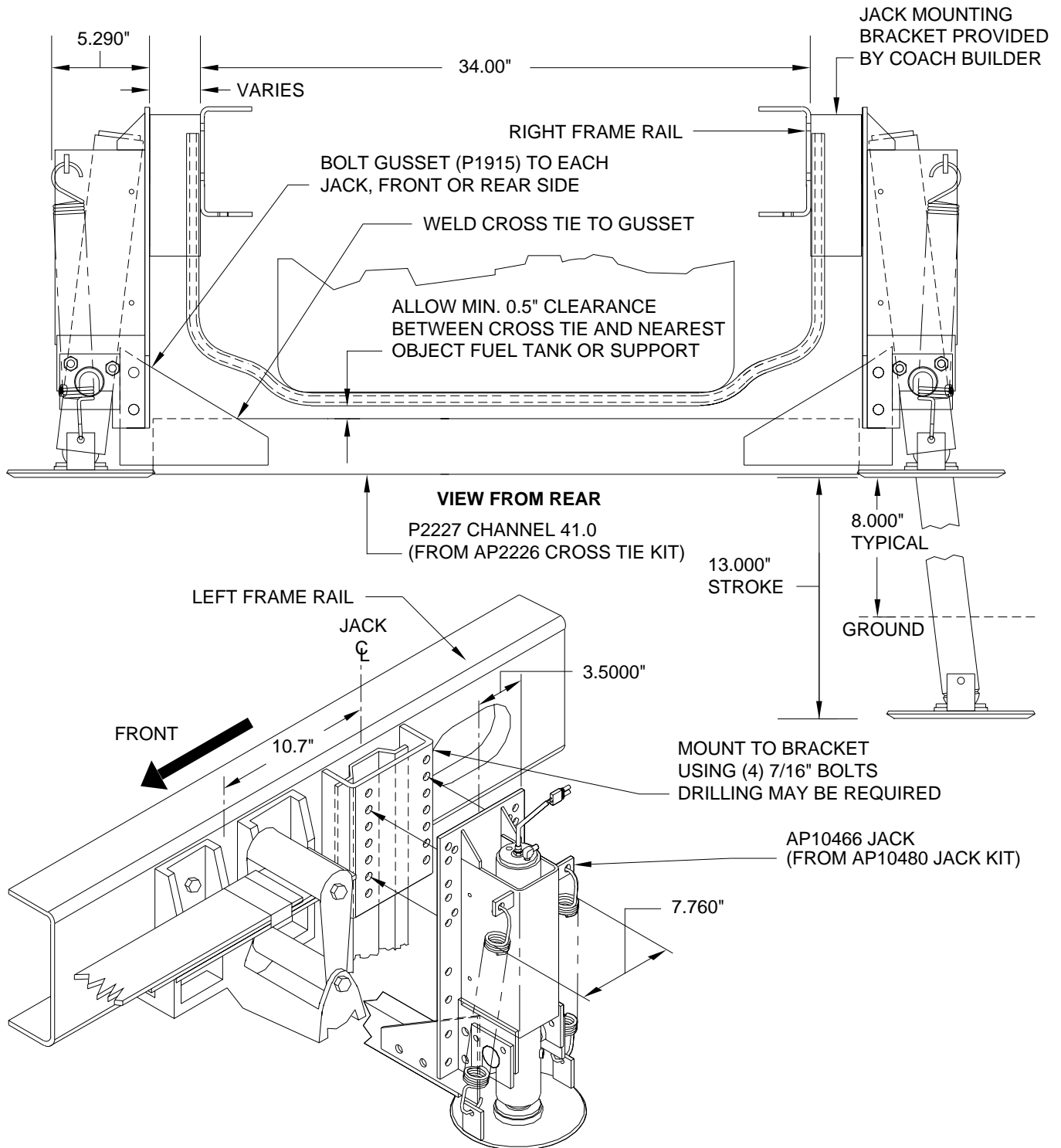

**CAUTION:** Follow CAUTIONS in Operator's and Installation Manuals concerning working under vehicles.

**MI25.2033**  
**03JUL01**