

| NO. | DATE | REVISION |
|-----|---------|-----------|
| 1 | 18NOV04 | UPDATED D |

| | | |
|---|--------------|-------------------------------|
| SCALE 1:1 | DATE 17FEB97 | DRAWN BY 1 |
| HWH 1-80 EXT 267 SOUTH RT 1 MOSCOW, IOWA 52760 | | |
| 310 LEVELLING SYSTEM | | |
| TT/FW | | DRAWING NUMBER MP88105 A/F |

THE INFORMATION DISCLOSED IN THIS DRAWING IS CONFIDENTIAL AND MUST NOT BE DISCLOSED OR USED IN ANY MANNER WHICH WILL BE DETRIMENTAL TO THE HWI CORPORATION

MP88, 105A
18FEB97

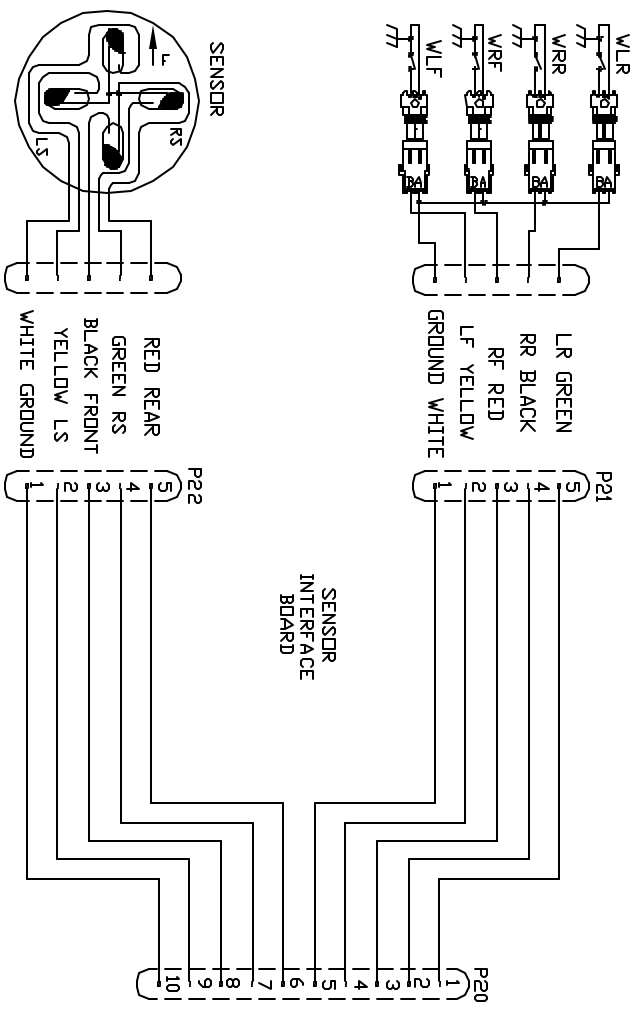

MP88: 105B
18FEB97

MP8105 B/F
17FEB97

FOR STRAIGHT ACTING JACKS, WARNING LIGHT/BUZZER WILL BE POWERED BY EXTERNAL FUSED IGNITION SOURCE.

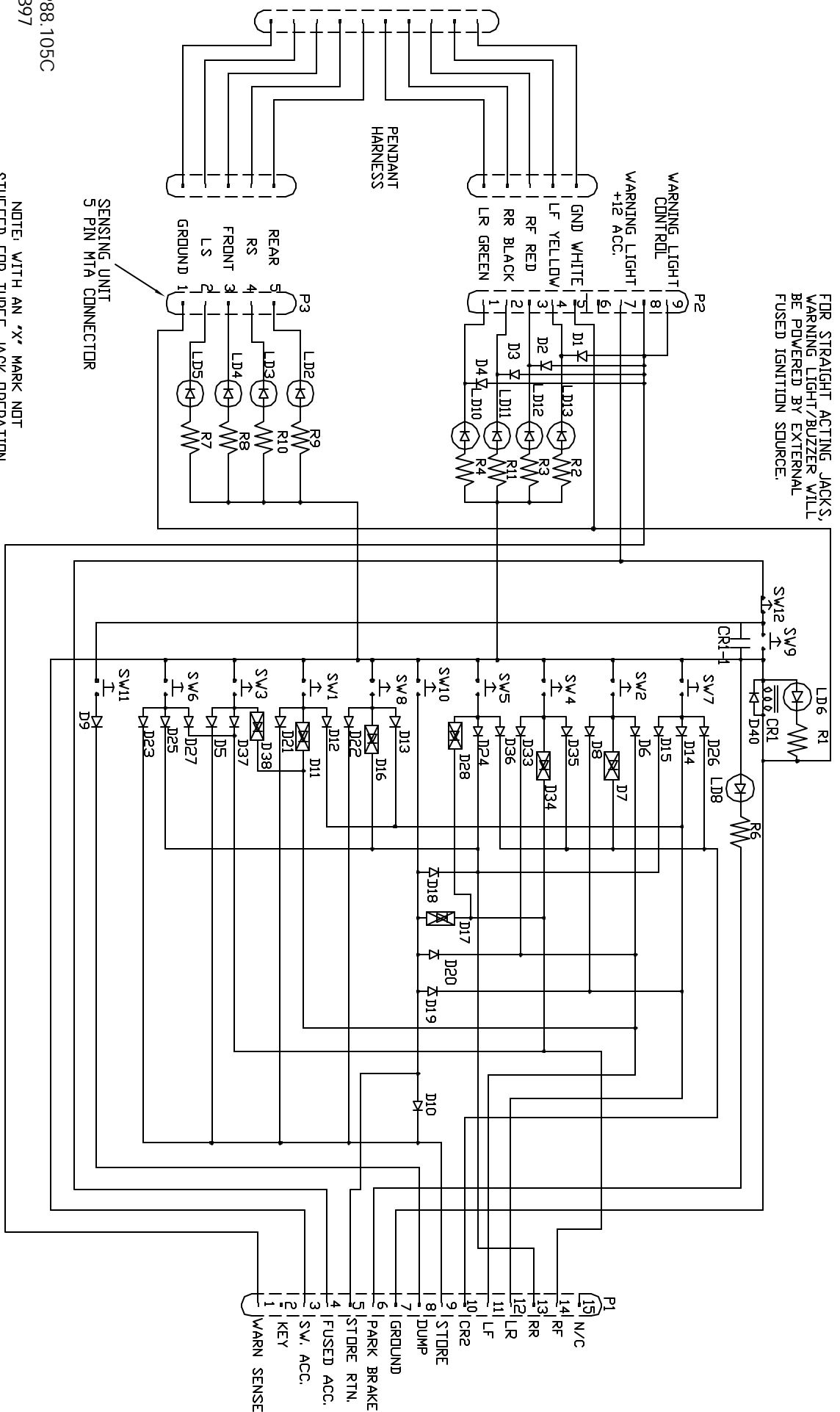

SENSING UNIT
5 PIN MTA CONNECTOR

PENDANT
HARNESS

NOTE: WITH AN 'X' MARK NOT
STUFFED FOR THREE JACK OPERATION.

MP88:105C
18FEB97

MP8105 C/F
17FEB97

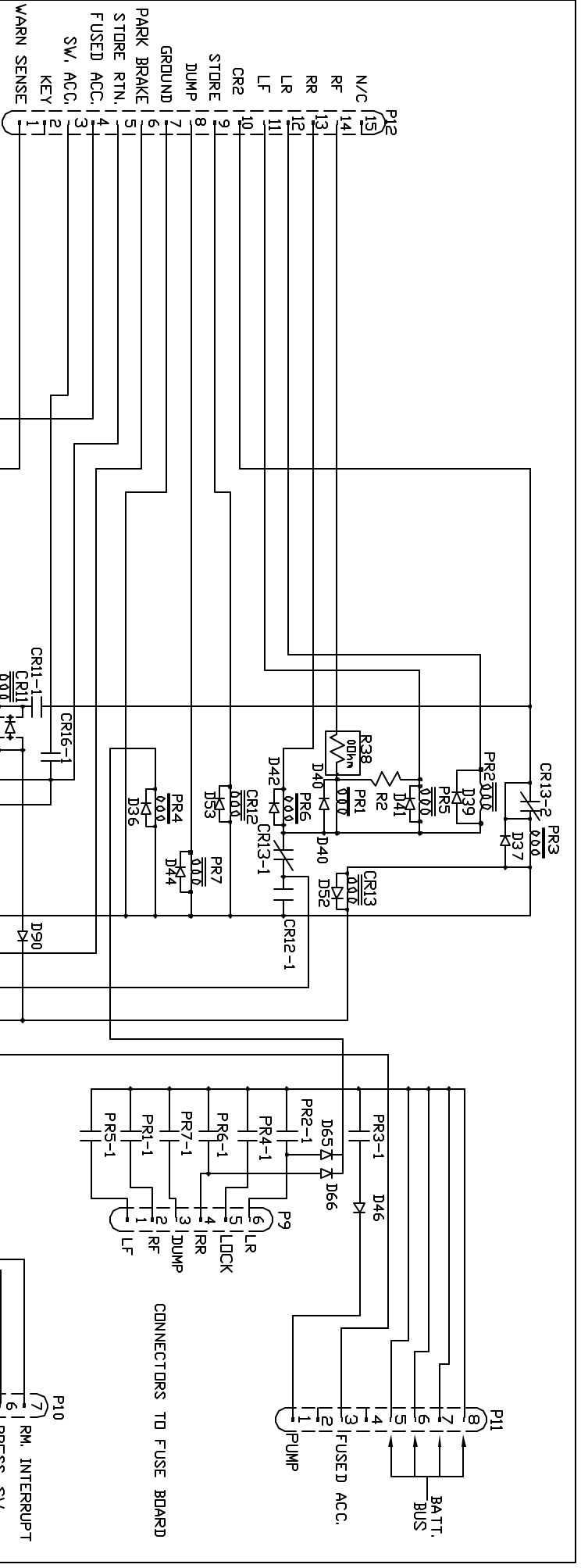

P12

- 15 N/C
- 14 RF
- 13 RR
- 12 LR
- 11 LF
- 10 CR2
- 9 STORE
- 8 DUMP
- 7 GROUND
- 6 PARK BRAKE
- 5 STORE RTN.
- 4 FUSED ACC.
- 3 SW, ACC.
- 2 KEY
- 1 WARN SENSE

NOTE: OBJECTS DRAWN WITH HIDDEN LINES ARE FOR OPTIONAL FRONT EQUALIZATION ONLY.

NOTE 'A', THIS TRACE ONLY A PART OF THE CIRCUIT WHEN CR11 IS PLACED IN THE LEFT SET OF HOLES.

NOTE 'B', ONLY USED WHEN FRONT JACK PRESSURE SWITCHES ARE MONITORED FOR STORE LATCH UP.

NOTE 'C', U1, PIN 4 AND 8 AND COIL OF CR14 MOVED TO FUSED ACC SIDE OF CR14 NC CONTACTS.

MP88, 105D
18NDV04

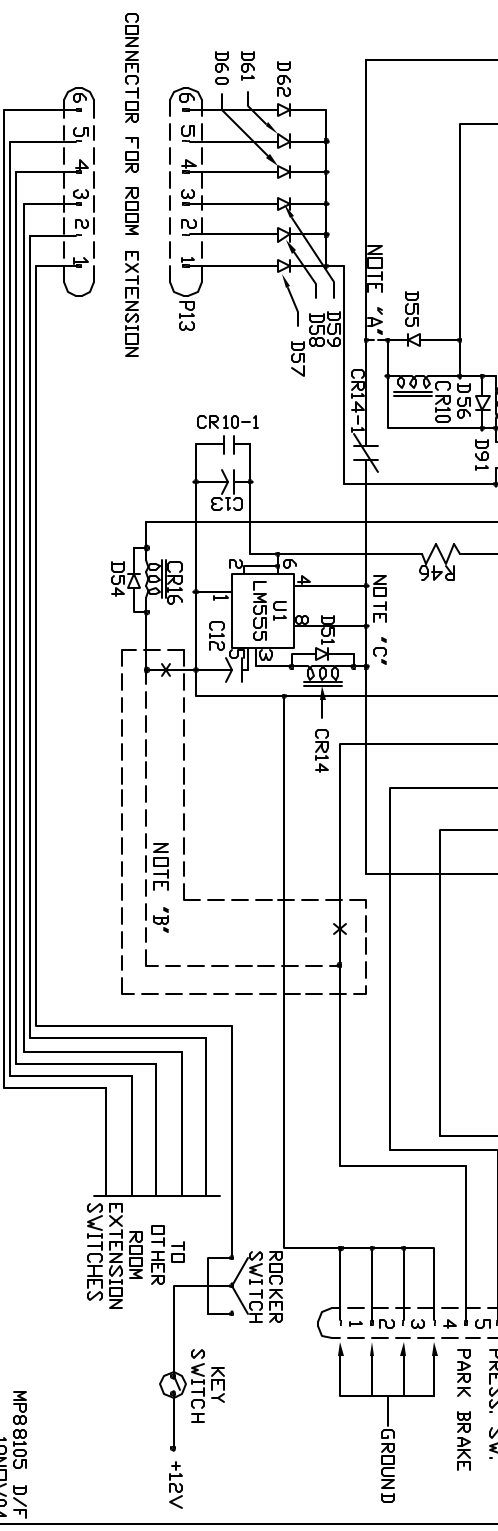

CONNECTOR FOR ROOM EXTENSION

CONNECTORS TO FUSE BOARD

TO OTHER ROOM EXTENSION SWITCHES

MP88105 D/F
18NDV04

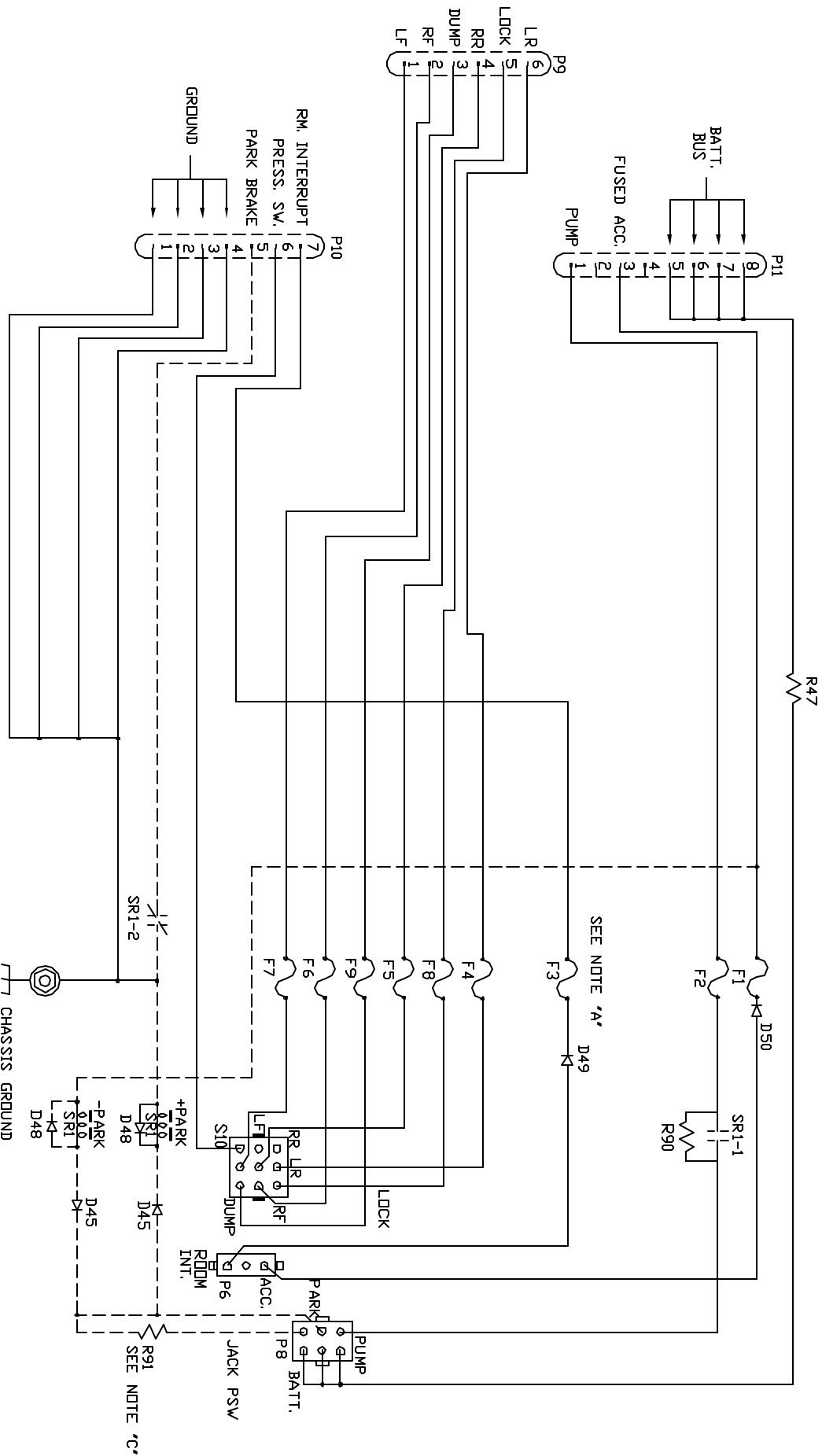

NOTE A: F3 IS REPLACED BY A JUMPER IN THIS SYSTEM.
 NOTE B: HIDDEN LINES NOT USED IN THIS SYSTEM. SR1-1
 13DEC01 REPLACED BY R90.
 NOTE C: R91 ONLY USED WHEN FRONT JACK PRESSURE
 SWITCHES ARE MONITORED FOR STORE LATCH UP.

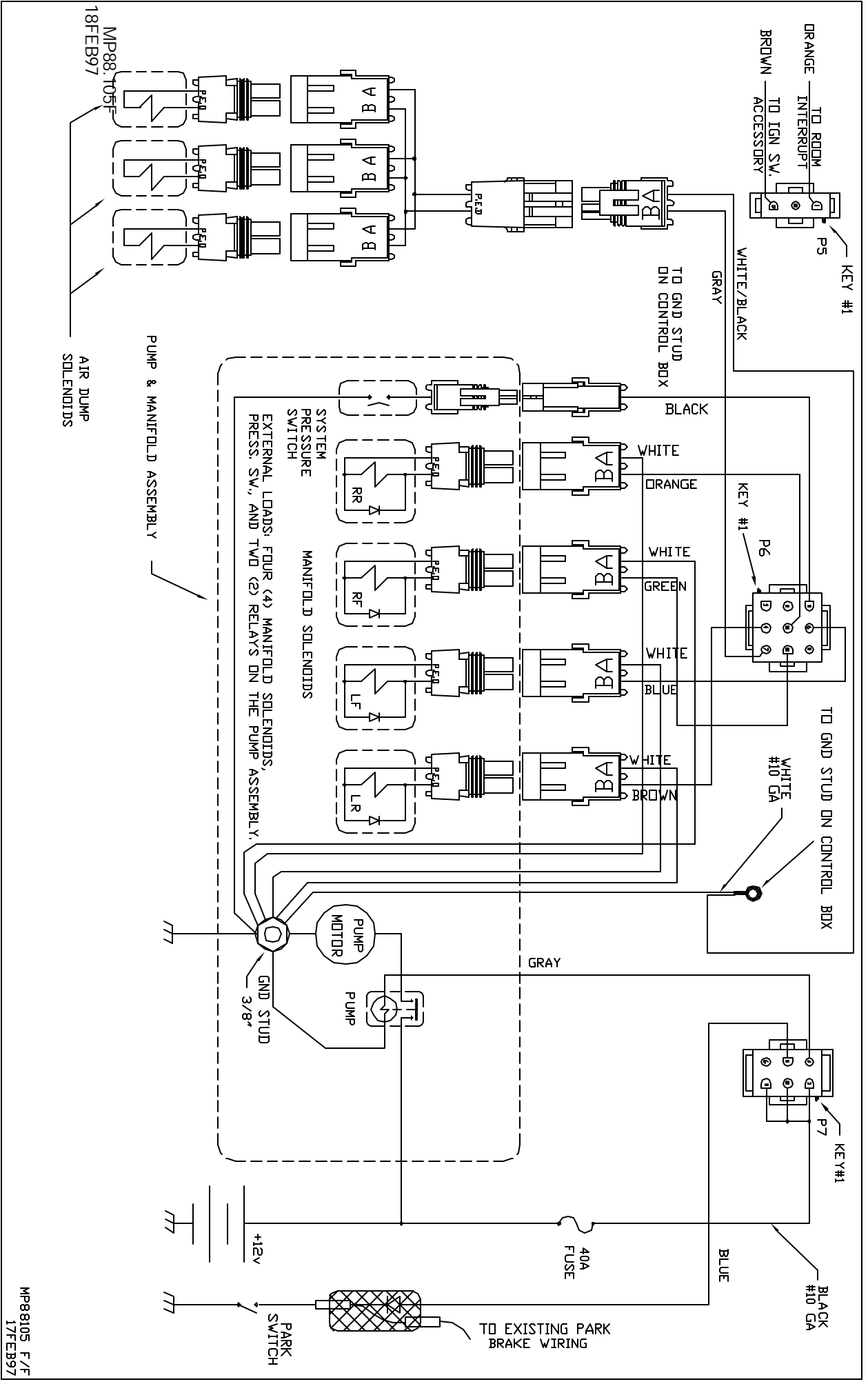

MP88105 F/F
17FEB97