

NOTE: AP39650 TOUCH PANEL AND AP31882 CHIME KIT WHICH INCLUDES AP31881 ARE ORDERED SEPARATELY FROM HWH CORP.

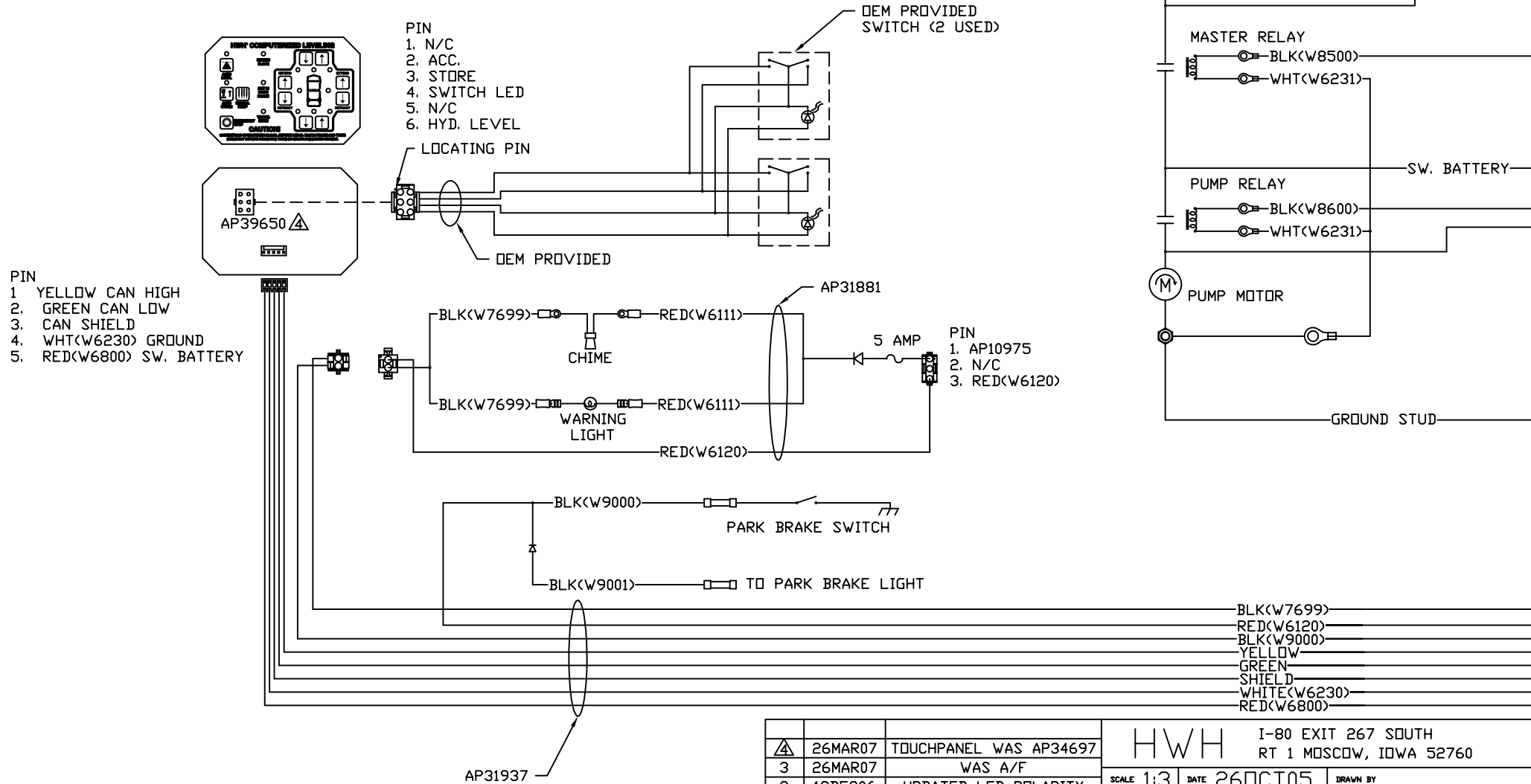

NOTE: INSTALLATION MUST CONFORM TO GOOD SHOP PRACTICES, SAE STANDARDS, RVIA STANDARDS, AND OTHER APPLICABLE STANDARDS.

| △   | 26MAR07 | TOUCHPANEL WAS AP34697 |
|-----|---------|------------------------|
| 3   | 26MAR07 | WAS A/F                |
| 2   | 13DEC06 | UPDATED LED POLARITY   |
| 1   | 23FEB06 | CORRECTED 6 PIN UML    |
| NO. | DATE    | REVISION               |

|                       |  |  |              |
|-----------------------|--|--|--------------|
| HWH                   |  | I-80 EXIT 267 SOUTH<br>RT 1 MOSCOW, IOWA 52760 |              |
|                       |  | SCALE 1:3                                      | DATE 26OCT05 |
| SYSTEM SCHEMATIC ELEC |  | DRAWN BY                                       |              |

THE INFORMATION DISCLOSED ON THIS DRAWING IS CONFIDENTIAL AND MUST NOT BE DISCLOSED OR USED IN ANY MANNER WHICH WILL BE DETRIMENTAL TO THE HWH CORPORATION

DRAWING NUMBER  
MP89556 A/F

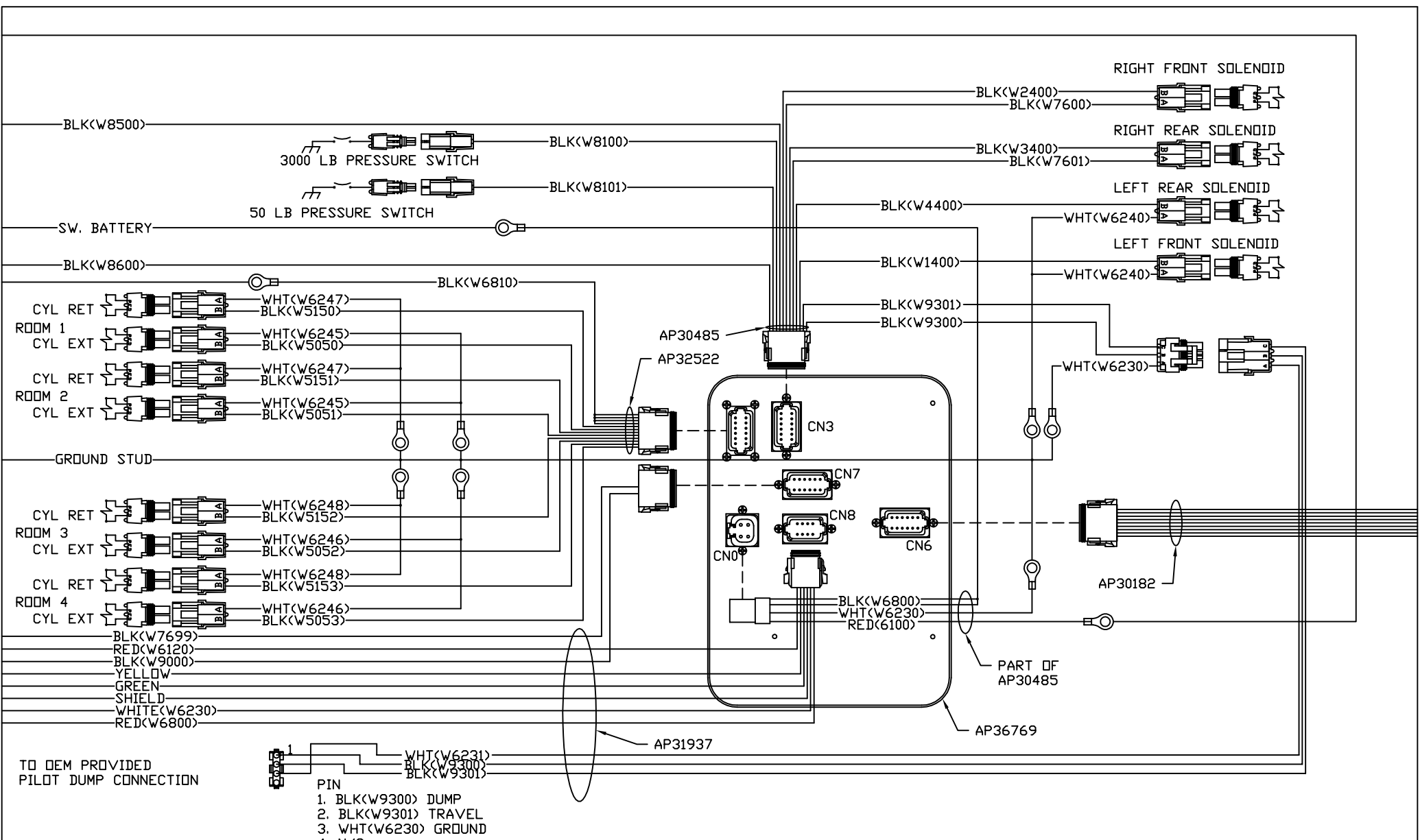

NOTE: INSTALLATION MUST CONFORM TO GOOD SHOP PRACTICES, SAE STANDARDS, RVIA STANDARDS, AND OTHER APPLICABLE STANDARDS.

NOTE: WIRE NUMBERS ON THIS SHEET ARE REFERENCED TO HARNESS PLUGS.

BLACK 12 PIN

1. BLK(W6810) SW. BATT ROOM 1
2. BLK(W5000) EXTEND ROOM 1
3. BLK(W5100) RETRACT ROOM 1
4. BLK(W6811) SW. BATT ROOM 2
5. BLK(W5001) EXTEND ROOM 2
6. BLK(W5101) RETRACT ROOM 2
7. N/C
8. N/C (KEY PIN)
9. N/C
10. BLK(W8601) PUMP
11. RED(W6100) BATTERY
12. N/C (KEY PIN)

BLACK 12 PIN

1. BLK(W6812) SW. BATT ROOM 3
2. BLK(W5002) EXTEND ROOM 3
3. BLK(W5102) RETRACT ROOM 3
4. BLK(W6813) SW. BATT ROOM 4
5. BLK(W5003) EXTEND ROOM 4
6. BLK(W5103) RETRACT ROOM 4
7. N/C
8. N/C (KEY PIN)
9. N/C (KEY PIN)
10. BLK(W8601) PUMP
11. RED(W6100) BATTERY
12. N/C

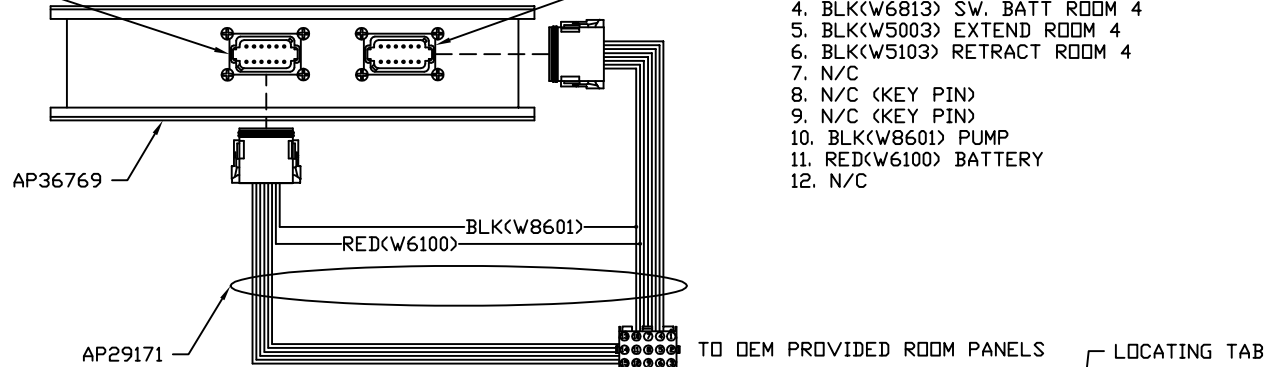

AP30182

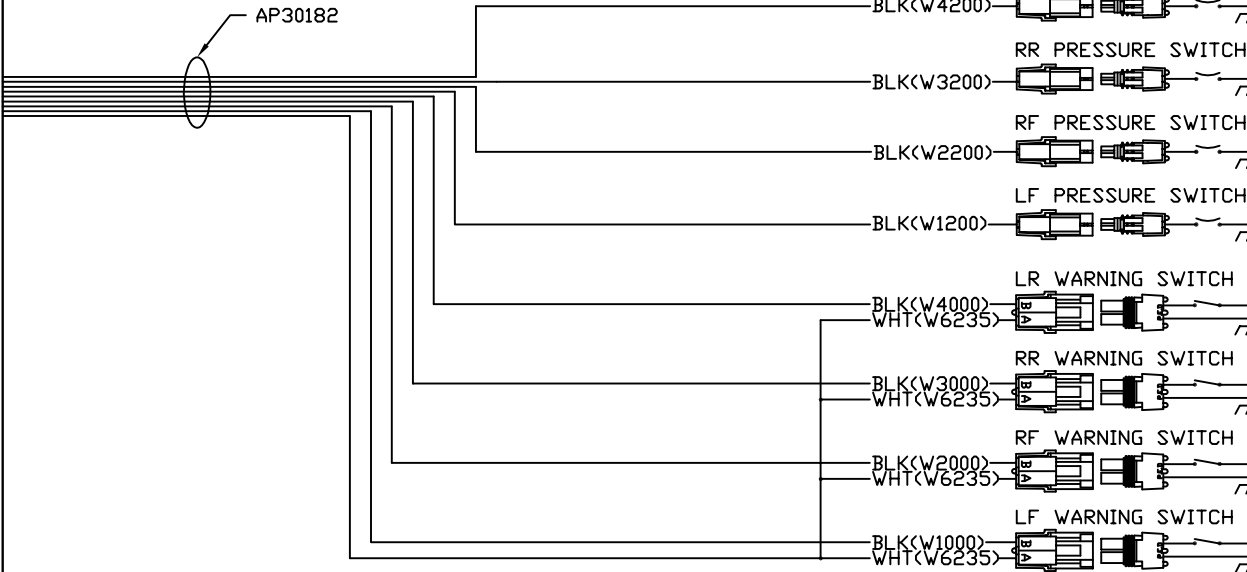

LR PRESSURE SWITCH

RR PRESSURE SWITCH

RF PRESSURE SWITCH

LF PRESSURE SWITCH

LR WARNING SWITCH

RR WARNING SWITCH

RF WARNING SWITCH

LF WARNING SWITCH

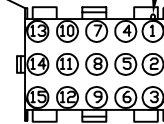

PIN

1. BLK(W5000) ROOM 1 EXTEND
2. BLK(W5100) ROOM 1 RETRACT
3. BLK(W6810) ROOM 1 SW. BATT.
4. BLK(W5001) ROOM 2 EXTEND
5. BLK(W5101) ROOM 2 RETRACT
6. BLK(W6811) ROOM 2 SW. BATT.
7. BLK(W5002) ROOM 3 EXTEND
8. BLK(W5102) ROOM 3 RETRACT
9. BLK(W6812) ROOM 3 SW. BATT.
10. BLK(W5003) ROOM 4 EXTEND
11. BLK(W5103) ROOM 4 RETRACT
12. BLK(W6813) ROOM 4 SW. BATT.
13. BLK(W8601) PUMP RELAY CONTROL
14. RED(W6100) BATTERY

NOTE: INSTALLATION MUST CONFORM TO GOOD SHOP PRACTICES, SAE STANDARDS, RVIA STANDARDS, AND OTHER APPLICABLE STANDARDS.

GREEN  
PIN

- 1 BLK(W5050) CYLINDER 1 EXTEND
- 2 BLK(W5150) CYLINDER 1 RETRACT
- 3 BLK(W5051) CYLINDER 2 EXTEND
- 4 BLK(W5151) CYLINDER 2 RETRACT
- 5 BLK(W5052) CYLINDER 3 EXTEND
- 6 BLK(W5152) CYLINDER 3 RETRACT
- 7 BLK(W5052) CYLINDER 4 EXTEND
- 8 BLK(W5052) CYLINDER 4 RETRACT
- 9 BLK(W6810) SW. BATTERY
- 10 BLK(W6810) SW. BATTERY
- 11 BLK(W6810) SW. BATTERY
- 12 BLK(W6810) SW. BATTERY

CN3 (BROWN)  
PIN

- 1 BLK(W8500) MASTER RELAY CONTROL
- 2 BLK(W8100) 3000 LB PRESS SW
- 3 BLK(W8101) 50 LB PRESS SW
- 4 BLK(W9301) TRAVEL
- 5 BLK(W1400) LF SOLENOID
- 6 BLK(W7600) CRX 1
- 7 BLK(W7601) CRX 2
- 8 BLK(W4400) LR SOLENOID
- 9 BLK(W3400) RR SOLENOID
- 10 BLK(W2400) RF SOLENOID
- 11 BLK(W9300) DUMP
- 12 BLK(W8600) PUMP RELAY CONTROL

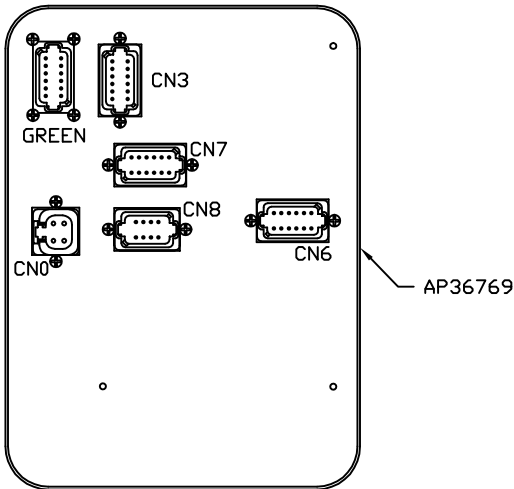
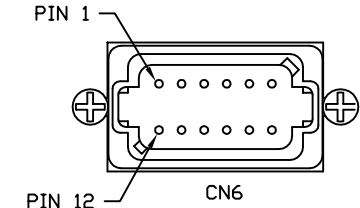
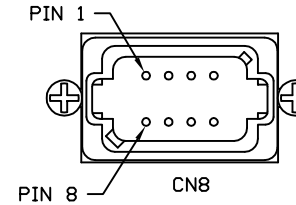
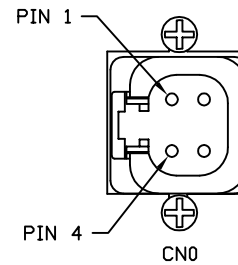
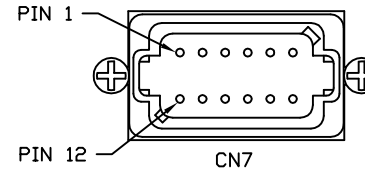
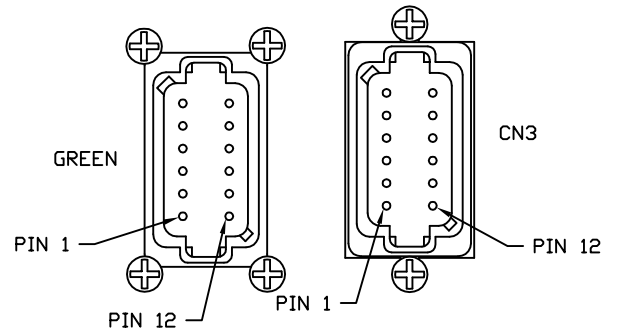

CN7 (BLACK)  
PIN

- 1 N/C
- 2 N/C
- 3 N/C
- 4 N/C
- 5 N/C
- 6 N/C
- 7 BLK(W9000) PARK BRAKE
- 8 N/C
- 9 N/C
- 10 N/C
- 11 BLK(W7699) WARN/CHIME CONTROL
- 12 N/C

NOTE: WIRE NUMBERS ON THIS SHEET ARE REFERENCED TO HARNESS PLUGS.

CN0 (GRAY)  
PIN

- 1 BLK(W6800) SW BATT
- 2 BLK(W6800) SW BATT
- 3 WHT(W6230) GROUND
- 4 RED(W6100) BATT

CN8 (BLACK)  
PIN

- 1 N/C
- 2 N/C
- 3 RED(W6800) SW BATT
- 4 WHT(W6230) GROUND
- 5 CAN SHIELD
- 6 RED(W6120) ACCESSORY
- 7 GREEN
- 8 YELLOW

CN6 (GRAY)  
PIN

- 1 N/C
- 2 N/C
- 3 BLK(W1000) LF WARN SW
- 4 BLK(W2000) RF WARN SW
- 5 BLK(W1200) LF PRESS SW
- 6 BLK(W2200) RF PRESS SW
- 7 BLK(W3200) RR PRESS SW
- 8 BLK(W4200) LR PRESS SW
- 9 BLK(W3000) RR WARN SW
- 10 BLK(W4000) LR WARN SW
- 11 N/C
- 12 WHT(W6235) GROUND

NOTE: INSTALLATION MUST CONFORM TO GOOD SHOP PRACTICES, SAE STANDARDS, RVIA STANDARDS, AND OTHER APPLICABLE STANDARDS.

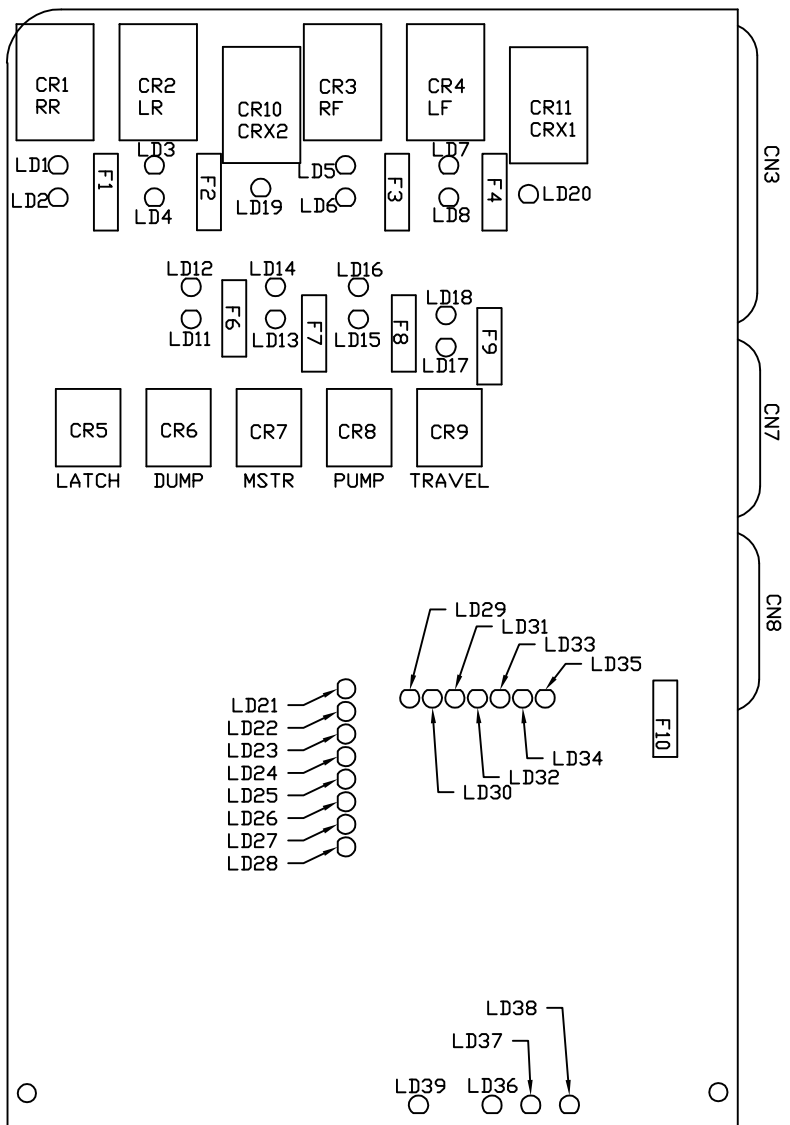

| LED #  | COLOR  | DESCRIPTION            |
|--------|--------|------------------------|
| LED 1  | YELLOW | RR COIL                |
| LED 2  | RED    | RR CONTACT             |
| LED 3  | YELLOW | LR COIL                |
| LED 4  | RED    | LR CONTACT             |
| LED 5  | YELLOW | RF COIL                |
| LED 6  | RED    | RF CONTACT             |
| LED 7  | YELLOW | LF COIL                |
| LED 8  | RED    | LF CONTACT             |
| LED 11 | YELLOW | DUMP COIL              |
| LED 12 | RED    | DUMP CONTACT           |
| LED 13 | YELLOW | MASTER RELAY COIL      |
| LED 14 | RED    | MASTER RELAY CONTACT   |
| LED 15 | YELLOW | PUMP COIL              |
| LED 16 | RED    | PUMP CONTACT           |
| LED 17 | YELLOW | TRAVEL COIL            |
| LED 18 | RED    | TRAVEL CONTACT         |
| LED 19 | YELLOW | CRX 2                  |
| LED 20 | YELLOW | CRX 1                  |
| LED 21 | YELLOW | LF WARN SW             |
| LED 22 | YELLOW | RF WARN SW             |
| LED 23 | YELLOW | RR WARN SW             |
| LED 24 | YELLOW | LR WARN SW             |
| LED 25 | RED    | LF PRESS SW            |
| LED 26 | RED    | RF PRESS SW            |
| LED 27 | RED    | RR PRESS SW            |
| LED 28 | RED    | LR PRESS SW            |
| LED 29 | RED    | NOT USED               |
| LED 30 | YELLOW | NOT USED               |
| LED 31 | GREEN  | 3000 LB PSW INPUT      |
| LED 32 | RED    | MASTER WARNING CONTROL |
| LED 33 | GREEN  | 50 LB PSW INPUT        |
| LED 34 | RED    | JACK INTERRUPT         |
| LED 35 | RED    | PARK BRAKE             |
| LED 36 | RED    | BOARD ENABLED          |
| LED 37 | RED    | ACCESSORY IN           |
| LED 38 | RED    | ACCESSORY OUT          |
| LED 39 | RED    | LINK LIGHT             |

| FUSE | RATING | DESCRIPTION   |
|------|--------|---------------|
| F1   | 15 AMP | RR OUTPUT     |
| F2   | 15 AMP | LR OUTPUT     |
| F3   | 15 AMP | RF OUTPUT     |
| F4   | 15 AMP | LF OUTPUT     |
| F6   | 5 AMP  | DUMP OUTPUT   |
| F7   | 5 AMP  | MASTER OUTPUT |
| F8   | 5 AMP  | PUMP OUTPUT   |
| F9   | 5 AMP  | TRAVEL OUTPUT |
| F10  | 10 AMP | ACC INPUT     |

NOTE: INSTALLATION MUST CONFORM TO GOOD SHOP PRACTICES, SAE STANDARDS, RVIA STANDARDS, AND OTHER APPLICABLE STANDARDS.